



Nouzové tahové lankové spínače Extreme ZS 90 S 2Ö/2S VD -40°C ... +85°C Extreme Číslo materiálu: 1184537 (Staré číslo materiálu: 76430501)

Vlastnosti/možnosti

- Temperature resistant from -40 °C to +85 °C
- Thermoplastic enclosure
- 4 contacts

- Wire length up to 2 x 50 m
- Release by lever
- Wire pull and breakage detection

Rozměry

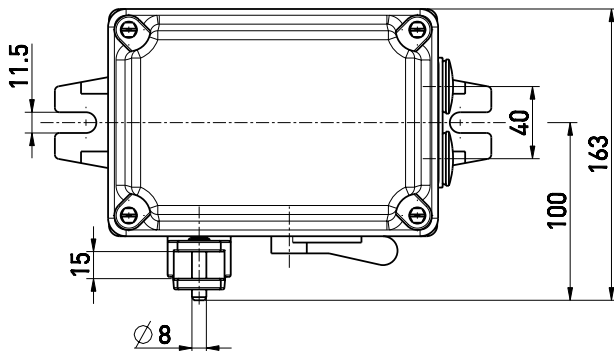
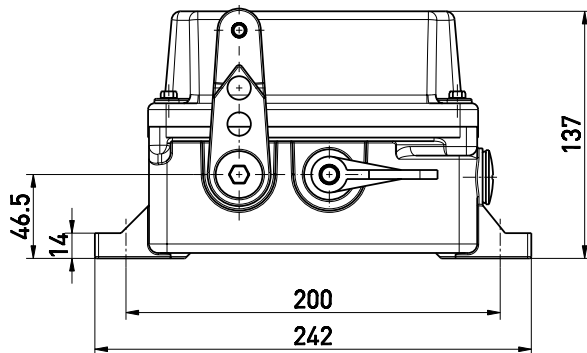

Schéma

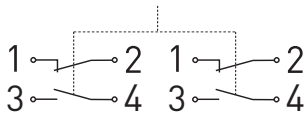

Note:

At 4 m distance intermediate wire supports are required. Two compensation springs type RZ-130K must be installed, see accessories.

Technická data

Standards	EN 60947-5-1, -5; EN ISO 13850; EN ISO 13849-1
Enclosure	Duroplast, UV resistant to EN ISO 4892
Cover	Duroplast, UV resistant to EN ISO 4892
Degree of protection	IP 67 to IEC/EN 60529
Contact material	silver
Switching elements	2 NC/2 NO contacts with double break
Switching system	snap action, positive break NC contacts ⊖
Connection	screw connection terminals
Cable cross-section	max. 2.5 mm ² (incl. conductor ferrules)
Cable entry	2 x M25 x 1.5
B _{10d} (10 % Load)	200 000
T _M	max. 20 years
U _{imp}	4 kV
U _i	400 V
I _{the}	10 A
Utilisation category	AC-15
I _e /U _e	1 A/230 VAC
Max. fuse rating	1 A gG/gN fuse
Ambient temperature	-40 °C ... +85 °C
Mechanical life	> 100 000 operations
Max. wire length	2 x 50 m
Features	wire pull and breakage detection
Gewicht	2072 g

Omyly a technické změny vyhrazeny.