



WB85

Displacement sensor with
measurement length
up to 6,000 mm



- Protection class up to IP67/IP69
- Robust stainless steel measurement tape
- Multiple deflections possible
- With magnetic absolute encoder
- Optional with integrated inclination sensor (WBT85)
- Redundant version available

Product versions



Analog output



Analog output, programmable



Analog output, redundant



Digital output SSI



Digital output CANopen, SAE J1939

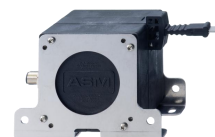

WB85 - Tape Extension Position Sensor
Version with analog output

Specifications

| | | | Order options |
|------------------------|--|----------|----------------|
| Measurement range | 5000 / 6000 mm | 1 | 5000 / 6000 |
| Resolution | <0.05 mm | | |
| Output | Voltage 0.5 ... 10 V Voltage 0.5 ... 4.5 V Current 4 ... 20 mA, 3 wire | 2 | U2 U8 I1 |
| Signal characteristics | Increasing (eg. 4 ... 20 mA) Decreasing (eg. 20 ... 4 mA) | 3 | A D |
| Linearity | ±0.10% f.s. (standard) ±0.05% f.s. (optional) | 4 | L10 L05 |
| Sensing device | Magnetic absolute encoder | | |
| Material | PBT, stainless steel Tape: stainless steel, 10 mm wide, 0,08 mm thick | | |
| Protection class | IP67/IP69 (with mating connector only) | | |
| Connection | Connector M12, 5 pin | 5 | M12R5 |
| Dust wiper | | 6 | BAB1 |
| Shock | DIN EN 60068-2-27:1993, 100 g/11 ms, 100 shocks | | |
| Vibration | DIN EN 60068-2-6:2008, 20 g 10 Hz-2 kHz, 10 cycles | | |
| Temperature range | -40 ... +85°C | | |
| Weight | approx. 1000 g with mounting brackets (250 g) | | |
| EMC | DIN EN 61326-1:2013 | | |

Order code

| | | | | | | | | | | | | |
|------|---|----------|---|----------|---|----------|---|----------|---|----------|---|----------|
| WB85 | - | 1 | - | 2 | - | 3 | - | 4 | - | 5 | - | 6 |
|------|---|----------|---|----------|---|----------|---|----------|---|----------|---|----------|

Order example: WB85 – 6000 – U2 – A – L10 – M12R5 – BAB1

Accessories:

Connector cable (see page 18)

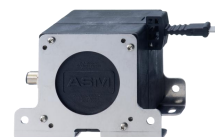

WB85 - Tape Extension Position Sensor
Version with analog output, programmable

Specifications

| | | | Order options |
|------------------------|--|----------|----------------------------|
| Measurement range | 5000 / 6000 mm | 1 | 5000 / 6000 |
| Resolution | <0.05 mm | | |
| Output | Voltage 0.5 ... 10 V, programmable Voltage 0.5 ... 4.5 V, programmable Current 4 ... 20 mA, 3 wire, programmable | 2 | U2/PMU U8/PMU I1/PMU |
| Signal characteristics | Increasing (eg. 4 ... 20 mA) Decreasing (eg. 20 ... 4 mA) | 3 | A D |
| Linearity | ±0.10% f.s. (standard) ±0.05% f.s. (optional) | 4 | L10 L05 |
| Sensing device | Magnetic absolute encoder | | |
| Material | PBT, stainless steel Tape: stainless steel, 10 mm wide, 0,08 mm thick | | |
| Protection class | IP67/IP69 (with mating connector only) | | |
| Connection | Connector M12, 5 pin | 5 | M12R5 |
| Dust wiper | | 6 | BAB1 |
| Shock | DIN EN 60068-2-27:1993, 100 g/11 ms, 100 shocks | | |
| Vibration | DIN EN 60068-2-6:2008, 20 g 10 Hz-2 kHz, 10 cycles | | |
| Temperature range | -40 ... +85°C | | |
| Weight | approx. 1000 g with mounting brackets (250 g) | | |
| EMC | DIN EN 61326-1:2013 | | |

Order code

| | | | | | | | | | | | | |
|------|---|----------|---|----------|---|----------|---|----------|---|----------|---|----------|
| WB85 | - | 1 | - | 2 | - | 3 | - | 4 | - | 5 | - | 6 |
|------|---|----------|---|----------|---|----------|---|----------|---|----------|---|----------|

Order example: WB85 – 6000 – U2/PMU – A – L10 – M12R5 – BAB1

Accessories:

Connector cable (see page 19)



WB85 - Tape Extension Position Sensor
Version with analog output, redundant

Specifications

| | | Order options |
|------------------------|--|----------------------------|
| Measurement range | 5000 / 6000 mm | 1 5000 / 6000 |
| Resolution | <0.05 mm | |
| Output | Voltage 0.5 ... 10 V, redundant Voltage 0.5 ... 4.5 V, redundant Current 4 ... 20 mA, 3 wire, redundant | 2 U2R U8R I1R |
| Signal characteristics | Output 1 increasing, output 2 increasing Output 1 increasing, output 2 decreasing Output 1 decreasing, output 2 decreasing | 3 A/A A/D D/D |
| Linearity | ±0.10% f.s. (standard) ±0.05% f.s. (optional) | 4 L10 L05 |
| Sensing device | Magnetic absolute encoder | |
| Material | PBT, stainless steel Tape: stainless steel, 10 mm wide, 0,08 mm thick | |
| Protection class | IP67/IP69 (with mating connector only) | |
| Connection | Connector M12, 8 pin | 5 M12R8 |
| Dust wiper | | 6 BAB1 |
| Shock | DIN EN 60068-2-27:1993, 100 g/11 ms, 100 shocks | |
| Vibration | DIN EN 60068-2-6:2008, 20 g 10 Hz-2 kHz, 10 cycles | |
| Temperature range | -40 ... +85°C | |
| Weight | approx. 1000 g with mounting brackets (250 g) | |
| EMC | DIN EN 61326-1:2013 | |

Order code

| | | | | | | | | | | | | |
|------|---|----------|---|----------|---|----------|---|----------|---|----------|---|----------|
| WB85 | - | 1 | - | 2 | - | 3 | - | 4 | - | 5 | - | 6 |
|------|---|----------|---|----------|---|----------|---|----------|---|----------|---|----------|

Order example: WB85 – 6000 – I1R – A/D – L10 – M12R8 – BAB1

Accessories:

Connector cable (see page 21)

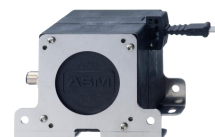

WB85 - Tape Extension Position Sensor
Version with digital output SSI

Specifications

| | | Order options |
|-------------------|--|----------------------|
| Measurement range | 5000 / 6000 mm | 1 5000 / 6000 |
| Resolution | 50 µm (other resolutions on demand) | 2 50 |
| Output | Digital output SSI | 3 MSSSI |
| Linearity | ±0.10% f.s. (standard) ±0.05% f.s. (optional) | 4 L10 L05 |
| Sensing device | Magnetic absolute encoder | |
| Material | PBT, stainless steel Tape: stainless steel, 10 mm wide, 0,08 mm thick | |
| Protection class | IP67/IP69 (with mating connector only) | |
| Connection | Connector M12, 8 pin | 5 M12R8 |
| Dust wiper | | 6 BAB1 |
| Shock | DIN EN 60068-2-27:1993, 100 g/11 ms, 100 shocks | |
| Vibration | DIN EN 60068-2-6:2008, 20 g 10 Hz-2 kHz, 10 cycles | |
| Temperature range | -40 ... +85°C | |
| Weight | approx. 1000 g with mountig brackets (250 g) | |
| EMC | DIN EN 61326-1:2013 | |

Order code

| | | | | | | | | | | | | |
|------|---|----------|---|----------|---|----------|---|----------|---|----------|---|----------|
| WB85 | - | 1 | - | 2 | - | 3 | - | 4 | - | 5 | - | 6 |
|------|---|----------|---|----------|---|----------|---|----------|---|----------|---|----------|

Order example: WB85 – 6000 – 50 – MSSSI – L10 – M12R8 – BAB1

Accessories:

Connector cable (see page 21)

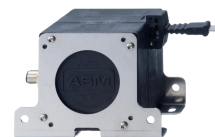

WB85 - Tape Extension Position Sensor
Version with digital output CANopen, SAE J1939

Specifications

| | | Order options |
|-------------------|--|------------------------------|
| Measurement range | 5000 / 6000 mm | 1 5000 / 6000 |
| Resolution | Setting via CAN Bus | |
| Output | CANopen SAE J1939 | 2 MCANOP MCANJ1939 |
| Linearity | ±0.10% f.s. (standard) ±0.05% f.s. (optional) | 3 L10 L05 |
| Sensing device | Magnetic absolute encoder | |
| Material | PBT, stainless steel Tape: stainless steel, 10 mm wide, 0,08 mm thick | |
| Protection class | IP67/IP69 (with mating connector only) | |
| Connection | Connector M12, 5 pin | 4 M12/CAN |
| Dust wiper | | 5 BAB1 |
| Shock | DIN EN 60068-2-27:1993, 100 g/11 ms, 100 shocks | |
| Vibration | DIN EN 60068-2-6:2008, 20 g 10 Hz-2 kHz, 10 cycles | |
| Temperature range | -40 ... +85°C | |
| Weight | approx. 1000 g with mounting brackets (250 g) | |
| EMC | DIN EN 61326-1:2013 | |

Order code

WB85 – **1** – **2** – **3** – **4** – **5**

Order example: WB85 – 6000 – MCANJ1939 – L10 – M12/CAN – BAB1

Accessories:

Connector cable (see page 20)

Dimensions

WB85

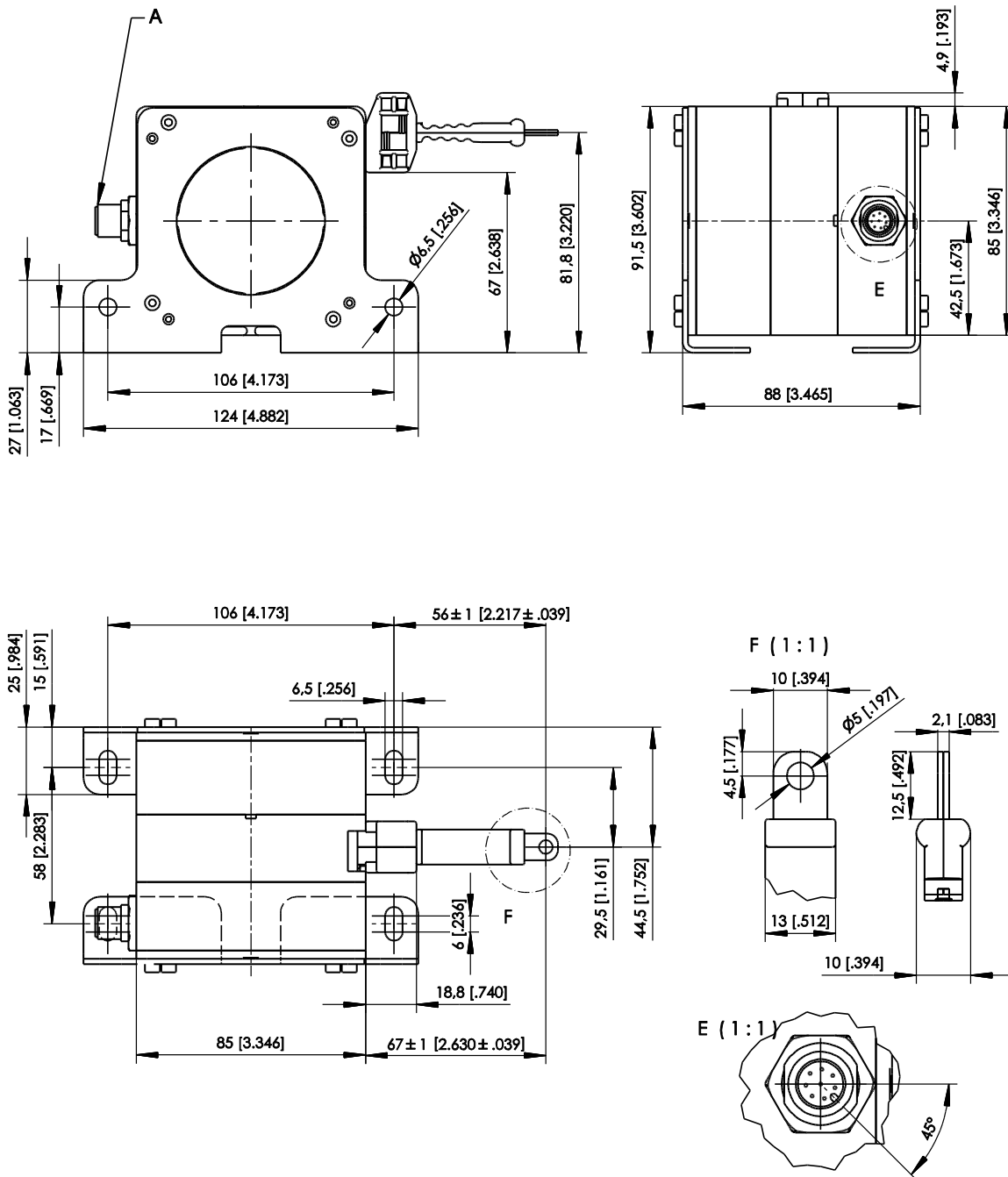

A – Connector M12

Dimensions in mm [inch]

Dimensions informative only.

For guaranteed dimensions consult factory.

Output specification

Analog output

| | | |
|--|-------------------------|--|
| U2 Voltage output 0.5 ... 10 V  | Excitation voltage | 8 ... 36 V DC |
| | Excitation current | 20 mA typical at 24 V DC 38 mA typical at 12 V DC max. 50 mA |
| | Output voltage | 0.5 ... 10 V DC |
| | Output current | 2 mA max. |
| | Measuring rate | 1 kHz standard |
| | Stability (temperature) | $\pm 50 \times 10^{-6}$ / °C f.s. (typical) |
| | Protection | Reverse polarity, short circuit |
| | Operating temperature | See specification of the respective sensor |
| | EMC | DIN EN 61326-1:2013 |

| | | |
|---|-------------------------|--|
| U8 Voltage output 0.5 ... 4.5 V  | Excitation voltage | 8 ... 36 V DC |
| | Excitation current | 17 mA typical at 24 V DC 32 mA typical at 12 V DC 50 mA max. |
| | Output voltage | 0.5 ... 4.5 V DC |
| | Output current | 2 mA max. |
| | Measuring rate | 1 kHz standard |
| | Stability (temperature) | $\pm 50 \times 10^{-6}$ / °C f.s. (typical) |
| | Protection | Reverse polarity, short circuit |
| | Operating temperature | See specification of the respective sensor |
| | EMC | DIN EN 61326-1:2013 |

| | | |
|--|-------------------------|---|
| I1 Current output 4 ... 20 mA, 3 wires  | Excitation voltage | 8 ... 36 V DC |
| | Excitation current | typical 36 mA at 24 V DC typical 70 mA at 12 V DC 120 mA max. |
| | Load R _L | 500 Ω max. |
| | Output current | 4 ... 20 mA |
| | Measuring rate | 1 kHz standard |
| | Stability (temperature) | $\pm 50 \times 10^{-6}$ / °C f.s. (typical) |
| | Protection | Reverse polarity, short circuit |
| | Operating temperature | See specification of the respective sensor |
| | EMC | DIN EN 61326-1:2013 |

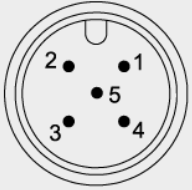
| Signal wiring | Output signals | Connector pin no. | Cable color |
|--|-----------------|-------------------|-------------|
| Connector M12, 5 pin  View to the sensor connector | Excitation + | 1 | brown |
| | Signal | 2 | white |
| | GND | 3 | blue |
| | Do not connect! | 4 | black |
| | Do not connect! | 5 | (grey) |

Analog output, programmable

| | | |
|--|-------------------------|--|
| U2/PMU Voltage output 0.5 ... 10 V  | Excitation voltage | 8 ... 36 V DC |
| | Excitation current | 20 mA typical at 24 V DC 38 mA typical at 12 V DC max. 50 mA |
| | Output voltage | 0,5 ... 10 V DC |
| | Output current | 2 mA max. |
| | Measuring rate | 1 kHz standard |
| | Stability (temperature) | $\pm 50 \times 10^{-6}$ / °C f.s. (typical) |
| | Protection | Reverse polarity, short circuit |
| | Operating temperature | See specification of the respective sensor |
| | EMC | EN 61326-1:2013 |

| | | |
|--|-------------------------|--|
| U8/PMU Voltage output 0.5 ... 4.5 V  | Excitation voltage | 8 ... 36 V DC |
| | Excitation current | 17 mA typical at 24 V DC 32 mA typical at 12 V DC max. 50 mA |
| | Output voltage | 0.5 ... 4.5 V DC |
| | Output current | 2 mA max. |
| | Measuring rate | 1 kHz standard |
| | Stabilität (Temperatur) | $\pm 50 \times 10^{-6}$ / °C f.s. (typical) |
| | Protection | Reverse polarity, short circuit |
| | Operating temperature | See specification of the respective sensor |
| | EMC | DIN EN 61326-1:2013 |

| | | |
|--|-------------------------|---|
| I1/PMU Current output 4 ... 20 mA, 3 wires  | Excitation voltage | 8 ... 36 V DC |
| | Excitation current | typical 36 mA at 24 V DC typical 70 mA at 12 V DC max. 120 mA |
| | Load R _L | 500 Ω max. |
| | Output current | 4 ... 20 mA |
| | Measuring rate | 1 kHz standard |
| | Stability (temperature) | $\pm 50 \times 10^{-6}$ / °C f.s. (typical) |
| | Protection | Reverse polarity, short circuit |
| | Operating temperature | See specification of the respective sensor |
| | EMC | DIN EN 61326-1:2013 |

Output .../PMU

Programming of the start and end value by the customer (programmable)

Teach-In of start and end value for the analog outputs U2/PMU, U8/PMU, I1/PMU is provided by a binary signal SPAN/ZERO. At the start position connect signal SPAN/ZERO for a period of 2 ... 3 seconds to GND via push button. At the end position connect signal SPAN/ZERO for a period of 5 ... 6 seconds to GND via a push button. The scaling range will be stored non-volatile.

To reset the sensor to factory default ZERO/END must be connected to ground while powering up the sensor for 2 ... 3 seconds.

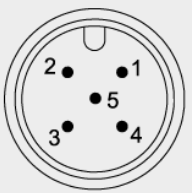
| Signal wiring | Output signals | Connector pin no. | Cable color |
|--|-----------------|-------------------|-------------|
| Connector M12, 5 pin  View to the sensor connector | Excitation + | 1 | brown |
| | Signal | 2 | white |
| | GND | 3 | blue |
| | Do not connect! | 4 | black |
| | SPAN/ZERO | 5 | grey |

Analog output, redundant

| | | |
|---|-------------------------|--|
| U2R Voltage output 0.5 ... 10 V  | Excitation voltage | 8 ... 36 V DC |
| | Excitation current | 20 mA typical at 24 V DC 38 mA typical at 12 V DC max. 50 mA per channel |
| | Output voltage | 0.5 ... 10 V DC |
| | Output current | 2 mA max. |
| | Measuring rate | 1 kHz standard |
| | Stability (temperature) | $\pm 50 \times 10^{-6}$ / °C f.s. (typical) |
| | Protection | Reverse polarity, short circuit |
| | Operating temperature | See specification of the respective sensor |
| | EMC | DIN EN 61326-1:2013 |

| | | |
|---|-------------------------|--|
| U8R Voltage output 0.5 ... 4.5 V  | Excitation voltage | 8 ... 36 V DC |
| | Excitation current | 17 mA typical at 24 V DC 32 mA typical at 12 V DC max. 50 mA per channel |
| | Output voltage | 0.5 ... 4.5 V DC |
| | Output current | 2 mA max. |
| | Measuring rate | 1 kHz standard |
| | Stability (temperature) | $\pm 50 \times 10^{-6}$ / °C f.s. (typical) |
| | Protection | Reverse polarity, short circuit |
| | Operating temperature | See specification of the respective sensor |
| | EMC | DIN EN 61326-1:2013 |

| | | |
|---|-------------------------|---|
| I1R Current output 4 ... 20 mA, 3 wires  | Excitation voltage | 8 ... 36 V DC |
| | Excitation current | 36 mA typical at 24 V DC 76 mA typical at 12 V DC max. 120 mA per channel |
| | Load R_L | 500 Ω max. |
| | Output current | 4 ... 20 mA |
| | Measuring rate | 1 kHz standard |
| | Stability (temperature) | $\pm 50 \times 10^{-6}$ / °C f.s. (typical) |
| | Protection | Reverse polarity, short circuit |
| | Operating temperature | See specification of the respective sensor |
| | EMC | DIN EN 61326-1:2013 |

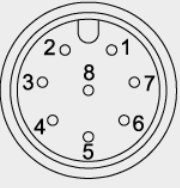
| Signal wiring | Channel | Output signals | Connector pin no. | Cable color |
|--|---------|-----------------|-------------------|-------------|
| Connector M12, 8 pin  View to the sensor connector | 1 | Excitation + | 1 | white |
| | | Signal | 2 | brown |
| | | GND | 3 | green |
| | | Do not connect! | 4 | yellow |
| | 2 | Excitation + | 5 | grey |
| | | Signal | 6 | pink |
| | | GND | 7 | blue |
| | | Do not connect! | 8 | red |

Digital output

| | | |
|--|--------------------------------------|--|
| MSSI Synchronous serial SSI  | Interface | EIA RS-422 |
| | Excitation voltage | 8 ... 36 V DC |
| | Excitation current | 19 mA typical at 24 V DC 35 mA typical at 12 V DC max. 80 mA |
| | Clock frequency | 100 kHz ... 500 kHz |
| | Code | Gray-Code, continuous progression |
| | Delay between pulse trains (t_p) | 30 μ s min. |
| | Stability (temperature) | $\pm 50 \times 10^{-6}$ / °C f.s. (typical) |
| | Operating temperature | See specification of the respective sensor |
| | Protection | Reverse polarity, short circuit |
| | EMC | DIN EN 61326-1:2013 |

Data format

(Train of 26 pulses)

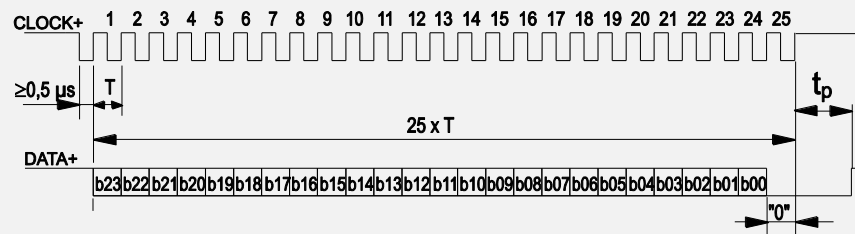

| Transmission rate | Cable length | Baud rate | Note: |
|-------------------|--------------|-------------|--|
| | 50 m | 100-400 kHz | Extension of the cable length will reduce the maximum transmission rate. |
| | 100 m | 100-300 kHz | |

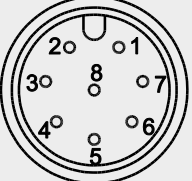
| Signal wiring | Output signals | Connector pin no. | Cable color |
|--|---------------------------|-------------------|-------------|
| Connector M12, 8 pin  View to the sensor connector | Excitation + | 1 | white |
| | Excitation GND | 2 | brown |
| | CLOCK | 3 | green |
| | $\overline{\text{CLOCK}}$ | 4 | yellow |
| | DATA | 5 | grey |
| | $\overline{\text{DATA}}$ | 6 | pink |
| | - | 7 | blue |
| | - | 8 | red |

| | | |
|---|-------------------------------------|--|
| MCANOP, CANOPR CANopen  | CAN specification | ISO 11898, Basic and Full CAN 2.0 B |
| | Communication profile | CANopen CiA 301 V 4.02, Slave |
| | Encoder profile | Encoder CiA 406 V 3.2 |
| | Error Control | Node Guarding, Heartbeat, Emergency Message |
| | Node ID | Adjustable via LSS or SDO, default: 127 |
| | PDO | 3 TxPDO, 0 RxPDO, no linking, static mapping |
| | PDO Modes | Event-/Time triggered, Remote-request, Sync cyclic/acyclic |
| | SDO | 1 Server, 0 Client |
| | CAM | 8 cams |
| | Certified | Yes |
| | Transmission rate | 50 kBit bis 1 Mbit, adjustable via LSS or SDO, default: 125 kBit |
| | Bus connection | M12 connector, 5 pin |
| | Integrated bus terminating resistor | 120Ω adjustable by the customer |
| | Bus, galvanic isolated | no |

| | | |
|-----------------------|-------------------------|--|
| Specifications | Excitation voltage | 8 ... 36 V DC |
| | Excitation current | 20 mA typical at 24 V DC 40 mA typical at 12 V DC 80 mA max. |
| | Measuring rate | 1 kHz (asynchronous) |
| | Stability (temperature) | $\pm 50 \times 10^{-6}/^{\circ}\text{C}$ f.s. (typical) |
| | Repeatability | 1 LSB |
| | Operating temperature | See specification of the respective sensor |
| | Protection | Reverse polarity, short circuit |
| | Dielectric strength | 1 kV (V AC, 50 Hz, 1 min.) |
| | EMC | EN 61326-1:2013 |

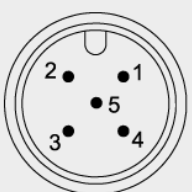
| Signal wiring | Output signals | Connector pin no. | Cable color |
|--|----------------|-------------------|-------------|
| Connector M12, 5 pin  | Shield | 1 | brown |
| | Excitation + | 2 | white |
| | GND | 3 | blue |
| | CAN-H | 4 | black |
| | CAN-L | 5 | grey |

View to the sensor connector

| | | |
|--|-------------------------------|-------------------------------------|
| MCANJ1939 SAE J1939  | CAN Specification | ISO 11898, Basic and Full CAN 2.0 B |
| | Transceiver | 24V-compliant, not isolated |
| | Communication profile | SAE J1939 |
| | Baud Rate | 250 kbit/s |
| | Internal termination resistor | 120 Ω adjustable by the customer |
| | Address | Default 247d, configurable |

| | | | |
|--------------------|---------------------------|-------------|----------------------|
| NAME Fields | Arbitrary address capable | 1 | Yes |
| | Industry group | 0 | Global |
| | Vehicle system | 7Fh (127d) | Non specific |
| | Vehicle system instance | 0 | |
| | Function | FFh (255d) | Non specific |
| | Function instance | 0 | |
| | ECU instance | 0 | |
| | Manufacturer | 145h (325d) | Manufacturer ID |
| | Identity number | 0nnn | Serial number 21 bit |

| | | | |
|--------------------------------------|--------------------|-----------|---|
| Parameter Group Numbers (PGN) | Configuration data | PGN EF00h | Proprietary-A (PDU1 peer-to-peer) |
| | Process data | PGN FFnnh | Proprietary-B (PDU2 broadcast); nn Group Extension (PS) configurable |

| | | |
|-----------------------|-------------------------|--|
| Specifications | Excitation voltage | 8 ... 36 V DC |
| | Excitation current | 20 mA typical at 24 V DC 40 mA typical at 12 V DC max. 80 mA |
| | Measuring rate | 1 kHz (asynchronous) |
| | Stability (temperature) | ±50 x 10 ⁻⁶ /°C f.s. (typical) |
| | Repeatability | 1 LSB |
| | Operating temperature | See specification of the respective sensor |
| | Protection | Reverse polarity, short circuit |
| | Dielectric strength | 1 kV (V AC, 50 Hz, 1 min.) |
| | EMV | EN 61326-1:2013 |

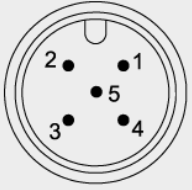
| Signal wiring | Output signals | Connector pin no. | Cable color |
|--|----------------|-------------------|-------------|
| Connector M12, 5 pin  View to the sensor connector | Shield | 1 | brown |
| | Excitation + | 2 | white |
| | GND | 3 | blue |
| | CAN-H | 4 | black |
| | CAN-L | 5 | grey |

Accessories

Connector cable M12, 4 pin (angular coupling)

shielded connector
Suitable for 5-pin
sensor connectors

The 4-core screened cable is supplied with a mating 4-pin 90° M12 connector at one end and 4 wires at the other end. Available lengths are 2 m, 5 m and 10 m.
Wire: cross sectional area 0.34 mm²
Cable diameter: 5.6 ±0.2 mm

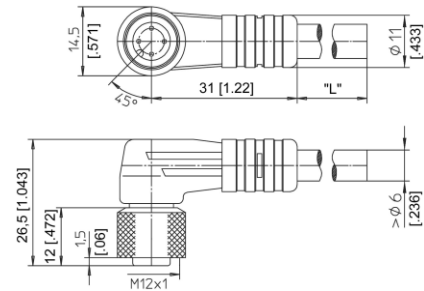

Order code

KAB - xM - M12/4F/W - LITZE

IP69: **KAB - xM - M12/4F/W/69K - LITZE**

xM = length in m

Connector cable M12, 4 pin (straight coupling)

shielded connector
Suitable for 5-pin
sensor connectors

The 4-core screened cable is supplied with a mating 4-pin M12 connector at one end and 4 wires at the other end. Available lengths are 2 m, 5 m and 10 m.
Wire: cross sectional area 0.34 mm²
Cable diameter: 5.6 ±0.2 mm

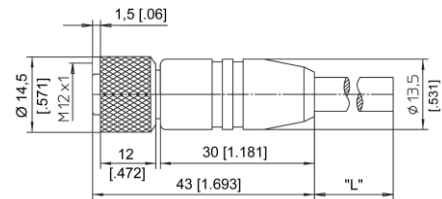

Order code

KAB - xM - M12/4F/G - LITZE

IP69: **KAB - xM - M12/4F/G/69K - LITZE**

xM = length in m

| Signal wiring M12, 4 pin | Plug connection / cable color | | | |
|-----------------------------|-------------------------------|-------|------|-------|
| | 1 | 2 | 3 | 4 |
| | brown | white | blue | black |

Applicable for cable carriers

| | |
|------------------------|---------------------|
| Maximum movement speed | 3 m/s |
| Maximum acceleration | 5 m/s ² |
| Minimum bending radius | 10 x cable diameter |

Connector cable M12, 5 pin (angular coupling)

shielded connector

The 5-core screened cable is supplied with a mating 5-pin 90° M12 connector at one end and 4 wires at the other end. Available lengths are 2 m, 5 m and 10 m.

Wire: cross sectional area 0.34 mm²

Cable diameter: 5.6 ±0.2 mm

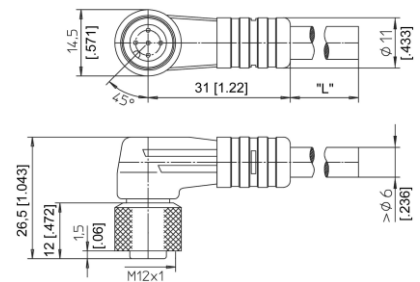

Order code

KAB - xM - M12/5F/W - LITZE

IP69: **KAB - xM - M12/5F/W/69K - LITZE**

xM = length in m

Connector cable M12, 5 pin (straight coupling)

shielded connector

The 5-core screened cable is supplied with a mating 5-pin M12 connector at one end and 4 wires at the other end. Available lengths are 2 m, 5 m and 10 m.

Wire: cross sectional area 0.34 mm²

Cable diameter: 5.6 ±0.2 mm

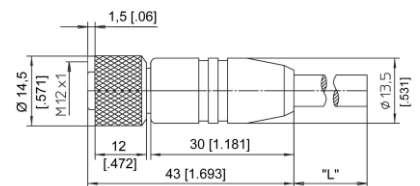

Order code

KAB - xM - M12/5F/G - LITZE

IP69: **KAB - xM - M12/5F/G/69K - LITZE**

xM = length in m

| Signal wiring M12, 5 pin | Plug connection / Cable color | | | | |
|-----------------------------|-------------------------------|-------|------|-------|------|
| | 1 | 2 | 3 | 4 | 5 |
| | brown | white | blue | black | grey |

Applicable for cable carriers

| | |
|------------------------|---------------------|
| Maximum movement speed | 3 m/s |
| Maximum acceleration | 5 m/s ² |
| Minimum bending radius | 10 x cable diameter |

Connector/bus cable M12, 5 pin CAN-Bus

The 5-lead shielded cable is supplied with a female 5 pin M12 connector at one end and a male 5 pin M12 connector at the other end.

Available lengths are 0.3 m, 2 m, 5 and 10 m.

Cable diameter: 6.7 ±0.2 mm

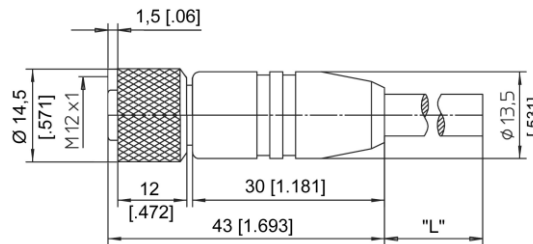

Order code

KAB - xM - M12/5F/G - M12/5M/G - CAN

IP69: **KAB - xM - M12/5F/G/69K - M12/5M/G/69K - CAN**

xM = length in m

T-connector for bus cable M12, 5 pin CAN-Bus

Order code

KAB - TCONN - M12/5M - 2M12/5F - CAN



Terminating resistor M12, 5 pin CAN-Bus

Order code

KAB - RTERM - M12/5M/G - CAN



Applicable for cable carriers

| | |
|------------------------|---------------------|
| Maximum movement speed | 3 m/s |
| Maximum acceleration | 5 m/s ² |
| Minimum bending radius | 10 x cable diameter |

Connector cable M12, 8 pin (angular coupling)

shielded connector

The 8-lead shielded cable is supplied with a mating 8-pin 90° M12 connector at one end and 8 wires at the other end. Available lengths are 2 m, 5 m and 10 m. Wire: cross sectional area 0.25 mm²
Cable diameter: 6.3 ±0.2 mm

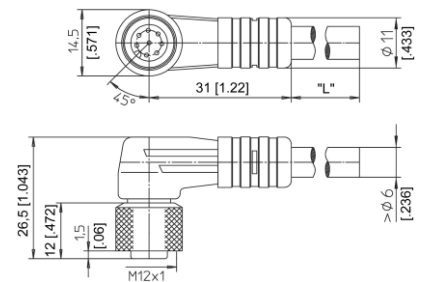

Order code

KAB - xM - M12/8F/W - LITZE

IP69: **KAB - xM - M12/8F/W/69K - LITZE**

xM = length in m

Connector cable M12, 8 pin (straight coupling)

shielded connector

The 8-lead shielded cable is supplied with a mating 8-pin M12 connector at one end and 8 wires at the other end. Available lengths are 2 m, 5 m and 10 m. Wire: cross sectional area 0.25 mm²
Cable diameter: 6.3 ±0.2 mm

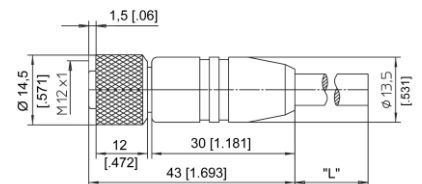

Order code

KAB - xM - M12/8F/G - LITZE

IP69: **KAB - xM - M12/8F/G/69K - LITZE**

xM = length in m

| Signal wiring M12, 8 pin | Plug connection / cable color | | | | | | | |
|-----------------------------|-------------------------------|-------|-------|--------|------|------|------|-----|
| | 1 | 2 | 3 | 4 | 5 | 6 | 7 | 8 |
| | white | brown | green | yellow | grey | pink | blue | red |

Applicable for cable carriers

| | |
|------------------------|---------------------|
| Maximum movement speed | 3 m/s |
| Maximum acceleration | 5 m/s ² |
| Minimum bending radius | 10 x cable diameter |

Tape pulley WBR1

Order code: WBR1

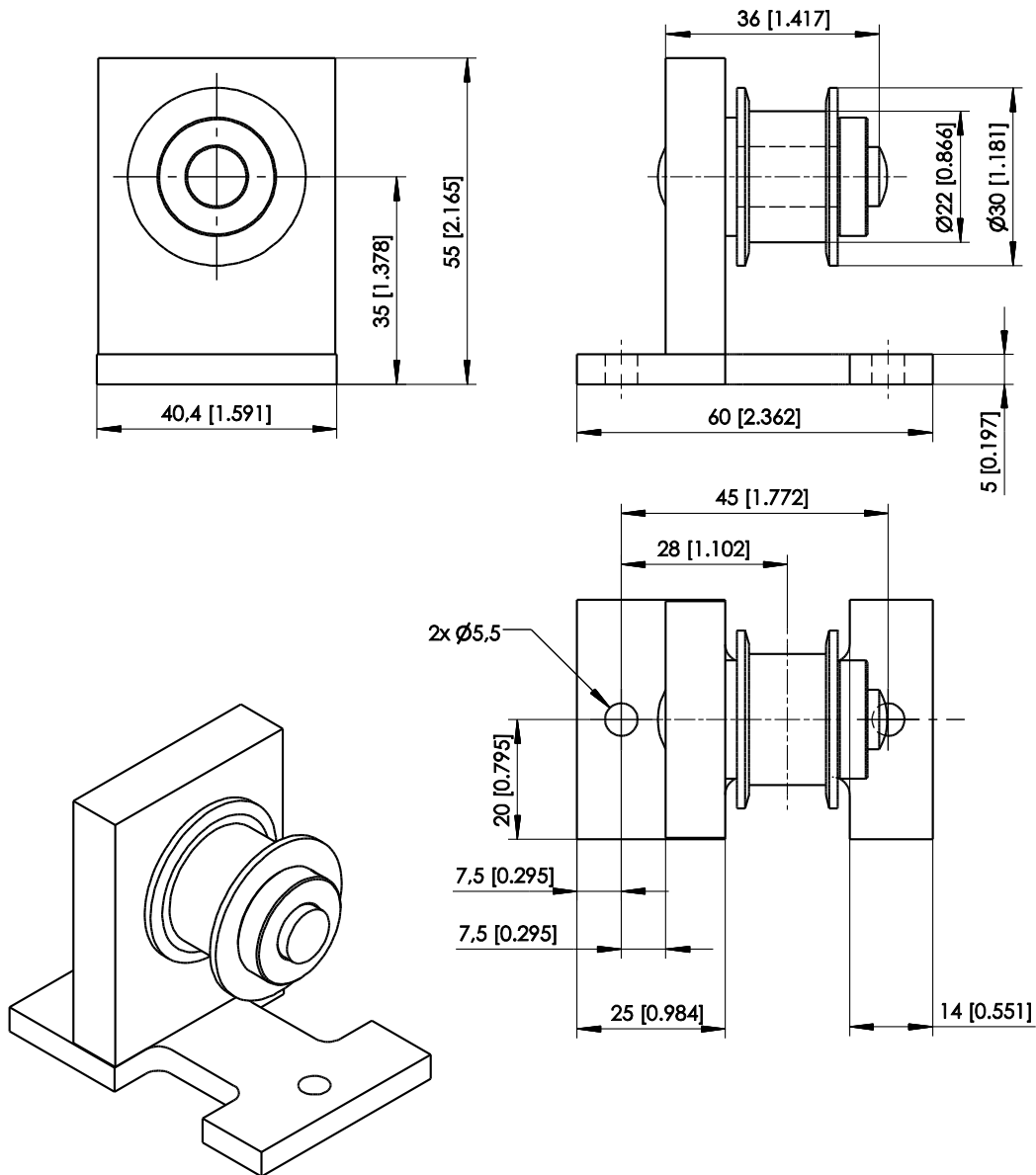

Dimensions in mm [inch]
Dimensions informative only.
For guaranteed dimensions consult factory.