

POSIROT® PRAS5EX - Dust-Ex-proof Magnetic Angle Sensor with Analog Output

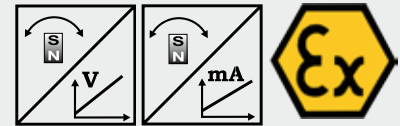

Magnetic angle sensor 0 - 360° in a flat housing with 66 mm resp. 68.2 mm dia.

- Measurement range 0 - 360°
- Protection class IP65
- Analog output
- With 10 mm shaft or non-contact
- Magnetic measurement principle
- Other outputs available on request
- Dust-Ex-proof: II 3D Ex tD A22 IP65 T80°C X
- SIL in preparation



Specifications	Outputs	U2	Voltage 0.5 ... 10 V
		U6 /5/ 8,25	I1
	Measurement range		0 ... 15° to 0 ... 360° in increments of 15°
	Resolution		0.03 % (60 ... 360°); 0.1 % (15 ... 45°)
	Repeatability		±0.03 % (60 ... 360°); ±0.1 % (15 ... 45°)
	Linearity		±0.3 % f.s. (typ.)
	Rated distance sensor / magnet		Depending on the position magnet
	Protection class		IP65
	Signal characteristics		CW, CCW
	Material		Stainless steel
	Mounting		Screws M8
	Shock		EN60068-2-27:1993, 100 g/11 ms, 100 shocks
	Vibration		EN60068-2-6:1995, 20 g 10 Hz-2 kHz, 10 cycles
	Life cycle of bearings (shaft version)		100 x 10 ⁶ revolutions (<1500 r.p.m.)
	Revolutions per minute (shaft version)		Max. 10,000 r.p.m.
	Allowable shaft load		120 N radial, 120 N axial
	Temperature		-20 to +40 °C
	Dust-Ex-proof standard		DIN EN61241-0, DIN EN61241-1

Order Code PRAS5EX

PRAS5EX - [] - [] - [] - [] - [] - []

Model name

Mechanical connection

V = Shaft 10 mm

K = Non-contact with external magnet

Measurement range 15 ... 360° in increments of 15°

15 / 30 / 45 / ... / 345 / 360

Outputs (see page 46)

U2 = 0.5 ... 10 V

U6/5 = 0.5 ... 4.5 V ratiometric, U_B = 5 V ±10%

I1 = 4 ... 20 mA, 3 wire

Signal characteristics

CW = Signal increasing CW

CCW = Signal increasing CCW

Connection

M12A5/M12R5 = 5-pin socket M12 axial/radial (compatible to 4-pin connector)

Housing material

VA = Stainless steel

Order code position magnet (see accessories page 53/54)

PRMAG ...

Order example: PRAS5EX - V - 360 - U6/5 - CW - M12R5 - VA

POSIROT®
PRAS5EX - Dust-Ex-proof
Dimensions



Outline drawing
Sensor PRAS5EX-K
M12, axial

Dimensions in mm [inch]

Dimensions informative only.
 For guaranteed dimensions
 consult factory.

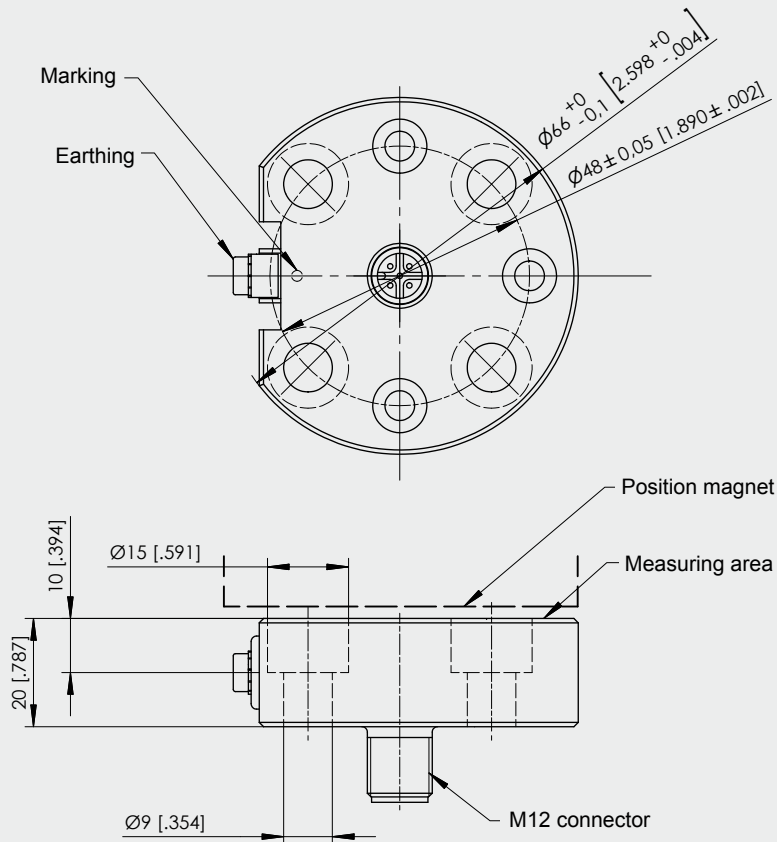

Outline drawing
Sensor PRAS5EX-K
M12, radial

Dimensions in mm [inch]

Dimensions informative only.
 For guaranteed dimensions
 consult factory.

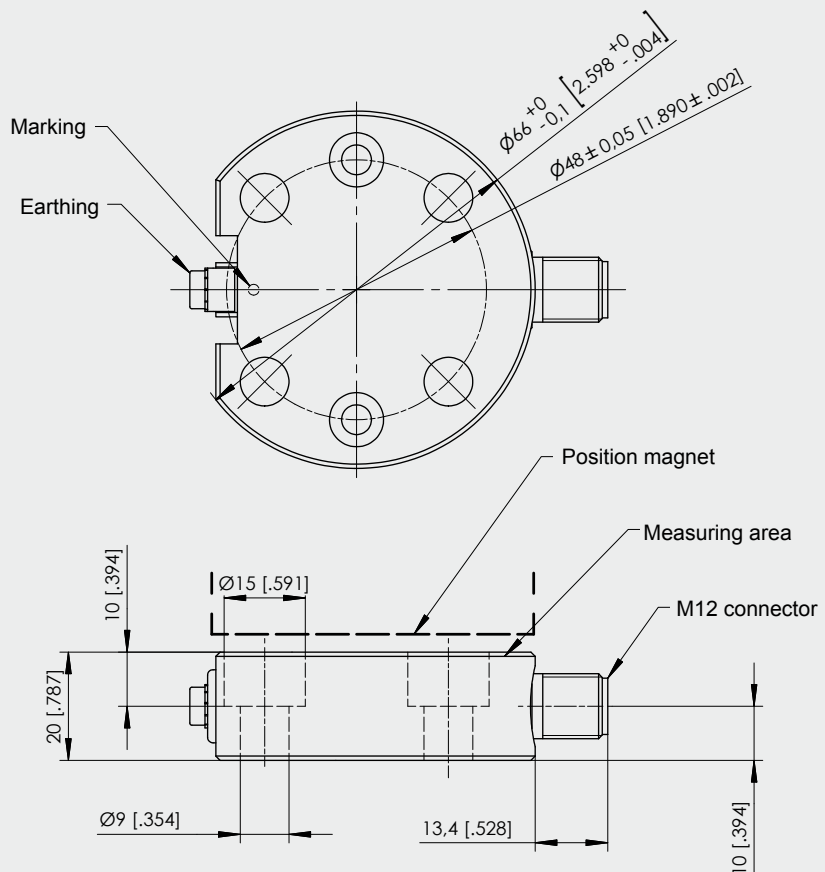

POSIROT®
PRAS5EX - Dust-Ex-proof
Dimensions



Outline drawing
Sensor PRAS5EX-V
M12, radial

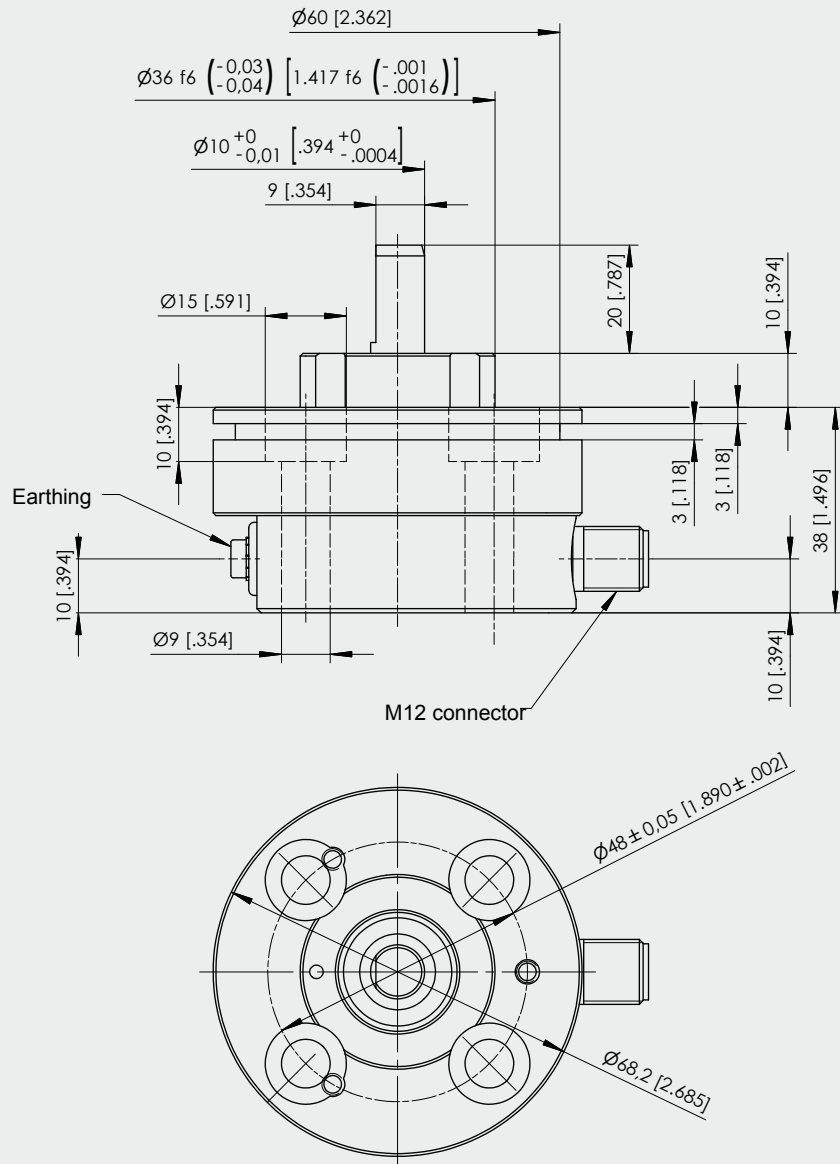

Dimensions in mm [inch]

Dimensions informative only.
 For guaranteed dimensions consult factory.

POSIROT®
PRAS5EX - Dust-Ex-proof
Dimensions



Outline drawing
Sensor PRAS5EX-V
M12, axial

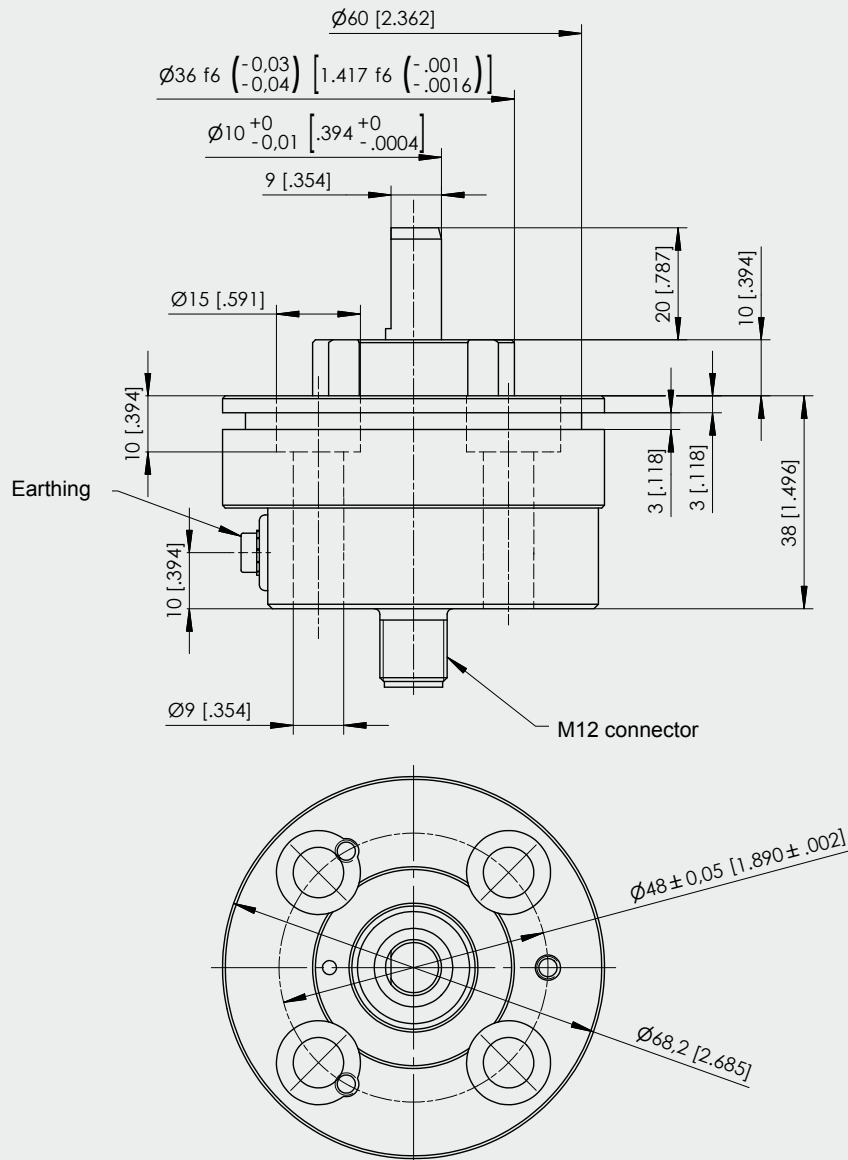

Dimensions in mm [inch]

Dimensions informative only.
 For guaranteed dimensions consult factory.

POSIROT®
PRAS
Analog outputs U2(B), U6 and I1(B)

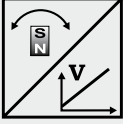
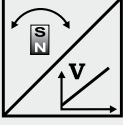
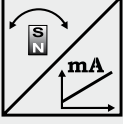

U2; U2B Voltage Output 0.5 ... 10 V 	Excitation voltage	U2: 18 ... 36 V DC; U2B: 11.5 ... 27 V DC
	Excitation current	12 mA typ., 16 mA max.
	Output voltage	0.5 ... 10 V DC
	Output current	2 mA max.
	Measuring rate	1 kHz standard
	Stability (temperature)	±50 x 10 ⁻⁶ / °C f.s. (typ.) for 90°...360° ±100 x 10 ⁻⁶ / °C f.s. (typ.) for <90°
	Operating temperature	-40 ... +85 °C (+105 °C as option)
	Protection	Reverse polarity, short circuit
EMC	EN61326-1:2006	
U6/5; U6/8,25 Voltage Output 10 ... 90% ratiometr. 	Excitation voltage	5V DC ±10 % / 8.25 V DC ±10 %
	Excitation current	8 mA typ., 12 mA max.
	Output voltage	10 ... 90 % of the excitation voltage
	Output current	2 mA max.
	Measuring rate	1 kHz standard
	Stability (temperature)	±50 x 10 ⁻⁶ / °C f.s. (typ.) for 90°...360° ±100 x 10 ⁻⁶ / °C f.s. (typ.) for <90°
	Operating temperature	-40 ... +85 °C (+125 °C as option)
	Protection	Reverse polarity, short circuit
EMC	EN61326-1:2006	
I1; I1B Current Output 4 ... 20 mA, 3 wire 	Excitation voltage	I1: 18 ... 36 V DC; I1B: 10 ... 18 V DC
	Excitation current	32 mA typ., 36 mA max.
	Load resistor	I1: 500 Ω max.; I1B: 250 Ω max.
	Output current	4 ... 20 mA
	Measuring rate	1 kHz standard
	Stability (temperature)	±50 x 10 ⁻⁶ / °C f.s. (typ.) for 90°...360° ±100 x 10 ⁻⁶ / °C f.s. (typ.) for <90°
	Operating temperature	-40 ... +85 °C
	Protection	Reverse polarity, short circuit
EMC	EN61326-1:2006	

Other outputs available on request.

Output signals

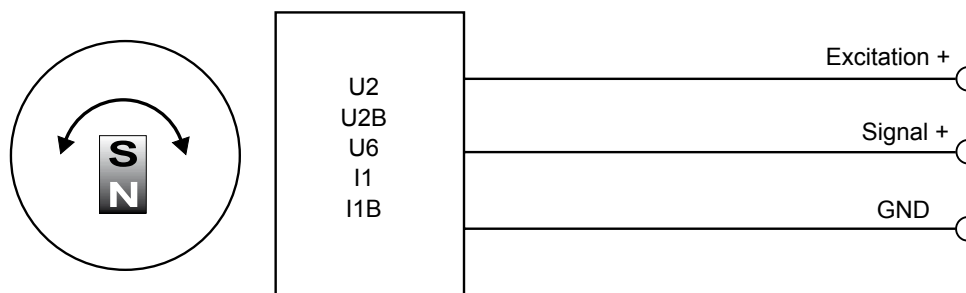

Signal Wiring	Output signals	Connector pin	Cable color
	Excitation +	1	brown
	Signal	2	white
	GND	3	blue
	Do not connect!	4	black
	Do not connect!	5	-

Connection

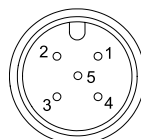

M12A5 / M12R5

View to sensor
connector

POSIROT[®]
PRAS/PRDS
Characteristics for magnetic angle sensors



Output signal
 (CW increasing)

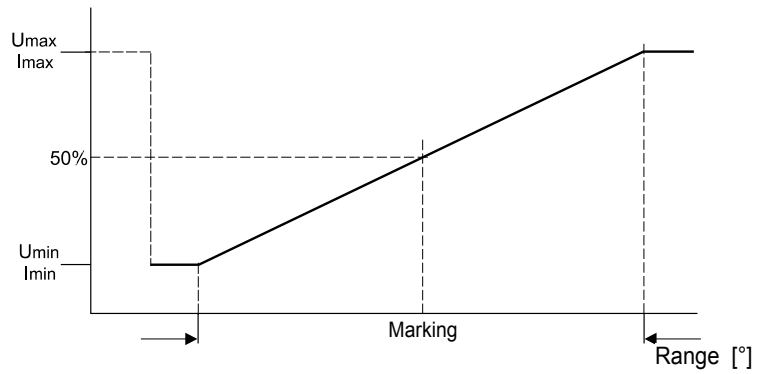

Output signal
 (CCW increasing)

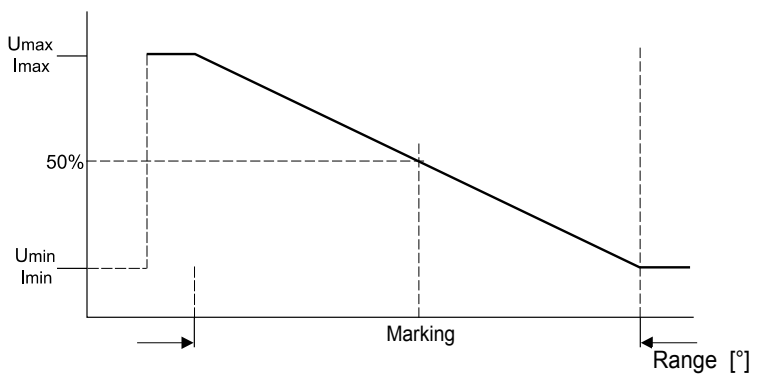

Example angular
range 90°

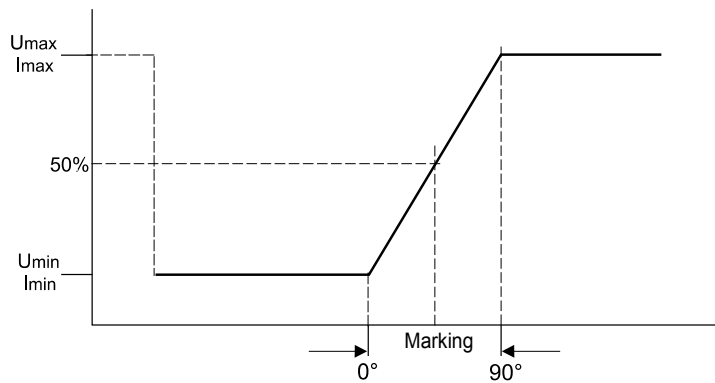

Example angular
range 360°

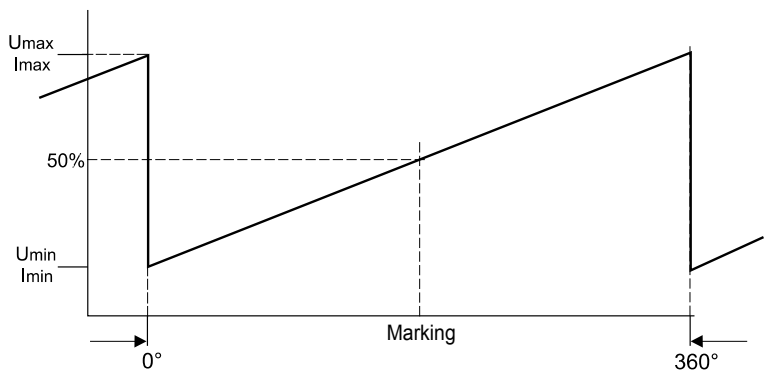

PRMAG2Z-EX

Weight ca. 22 g approx.
 moment of inertia 4.5 kgmm²
 A misalignment of the position magnet
 has an effect on the linearity

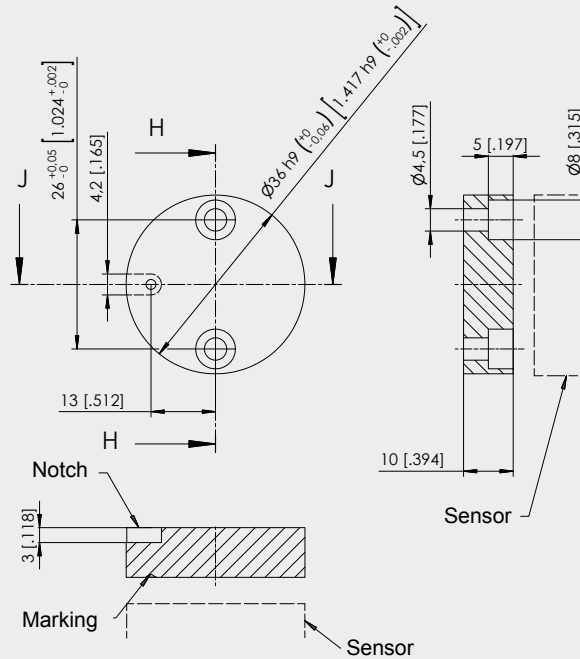

PRMAG5-EX

Weight ca. 275 g approx.
 moment of inertia 150 kgmm²
 A misalignment of the position magnet
 has an effect on the linearity

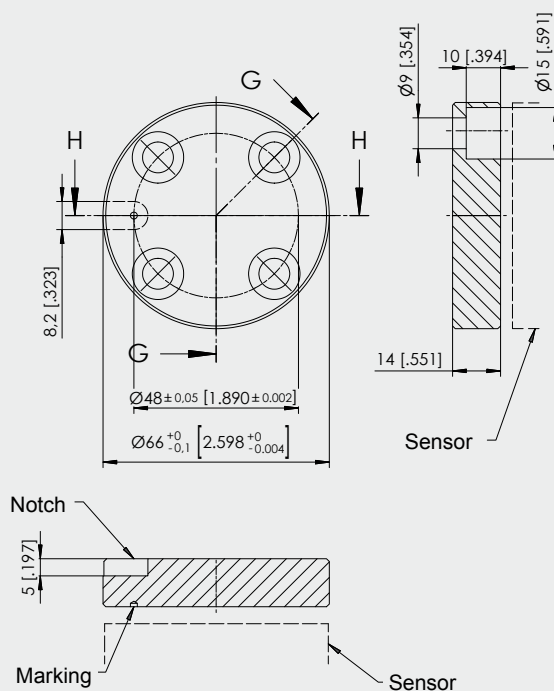

EX - Explanation (II 3D Ex tD A22 IP65 T80°C X)

- II** = for all Explosive Areas, excluding Surface and Underground Mining Systems
- 3D** = Equipment Category 3, applicable in Zone 22; D = dust
- Ex** = meets the requirements of the European Ex-Directive
- tD** = type of ignition protection: protection by enclosure "tD"
- A22** = measurement of the surface temperature acc. to procedure A for applications in Zone 22
- IP65** = IP Protection Class
- T80°C** = maximum surface temperature
- X** = tested with low impact energy

POSIROT® / POSITILT®

Accessories

Connector Cables



Connector cable for POSIROT®-POSITILT® sensors
4 pins M12

Suitable for 5-pin sensor connectors M12A5 and M12R5

The 4-core screened cable is supplied with a mating 4-pin 90° M12 connector at one end and 4 wires at the other end. Available lengths are 2, 5 and 10 m.

Order code:

KAB - XM - M12/4F/W - LITZE

IP69K: **KAB - XM - M12/4F/W/69K - LITZE**

Length in m

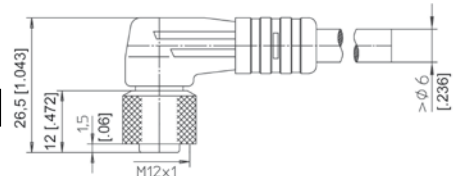
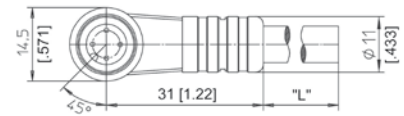

Connector cable for POSIROT®-POSITILT® sensors
4 pins M12

Suitable for 5-pin sensor connectors M12A5 and M12R5

The 4-core screened cable is supplied with a mating 4-pin M12 connector at one end and 4 wires at the other end. Available lengths are 2, 5 and 10 m.

Order code:

KAB - XM - M12/4F/G - LITZE

IP69K: **KAB - XM - M12/4F/G/69K - LITZE**

Length in m

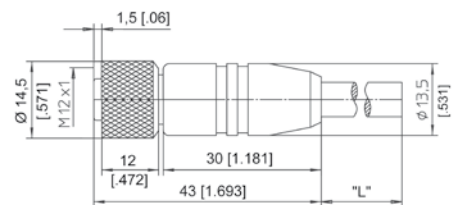

Signal wiring M12, 4 pin	Connector pin / cable color			
	1	2	3	4
	Brown	White	Blue	Black

Connector cable for POSIROT®-POSITILT® sensors
8 pins M12

The 8-core screened cable is supplied with a mating 8-pin 90° M12 connector at one end and 8 wires at the other end. Available lengths are 2, 5 and 10 m.

Order code:

KAB - XM - M12/8F/W - LITZE

IP69K: **KAB - XM - M12/8F/W/69K - LITZE**

Length in m

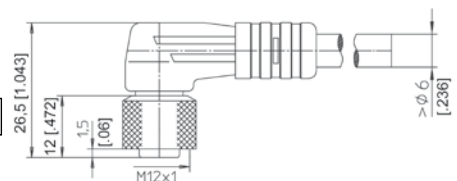
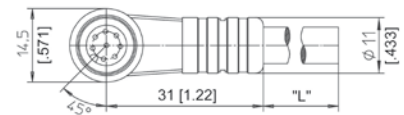

Connector cable for POSIROT®-POSITILT® sensors
8 pins M12

The 8-core screened cable is supplied with a mating 8-pin M12 connector at one end and 8 wires at the other end. Available lengths are 2, 5 and 10 m.

Order code:

KAB - XM - M12/8F/G - LITZE

IP69K: **KAB - XM - M12/8F/G/69K - LITZE**

Length in m

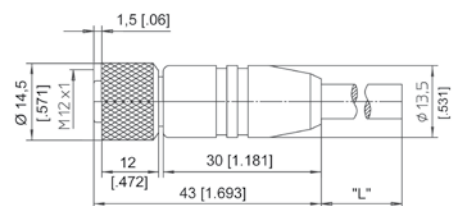

Signal wiring M12, 8 pin	Connector pin / cable color							
	1	2	3	4	5	6	7	8
	White	Brown	Green	Yellow	Grey	Pink	Blue	Red