

# SPECTRO Series

## ► SPECTRO-3-50-FCL-JR

- Measuring range typ. 20 mm ... 150 mm
- Big dynamic range due to focused white-light operation
- Up to 31 colors can be stored
- RS232 interface (USB adapter is available)
- 8x super-bright white-light LED, focused (AC-/DC-/PULSE-operation or OFF for luminous objects can be switched)
- Color detection, contrast detection, and gray scale detection
- Insensitive to outside light
- Brightness correction can be activated
- Switching frequency up to 35 kHz
- TEACH via PC or external input
- Various evaluation algorithms can be activated
- Averaging can be activated (from 1 up to over 32000 values)
- Color control of luminous objects (LEDs, halogen lamps, displays, ...)
- "BEST HIT" mode ("human color assessment")
- 3-color filter detector (true color detector: "human color perception")
- Temperature compensated based on empirical values



## Design

### Product name:

### SPECTRO-3-50-FCL-JR

(incl. software SPECTRO3-Scope)

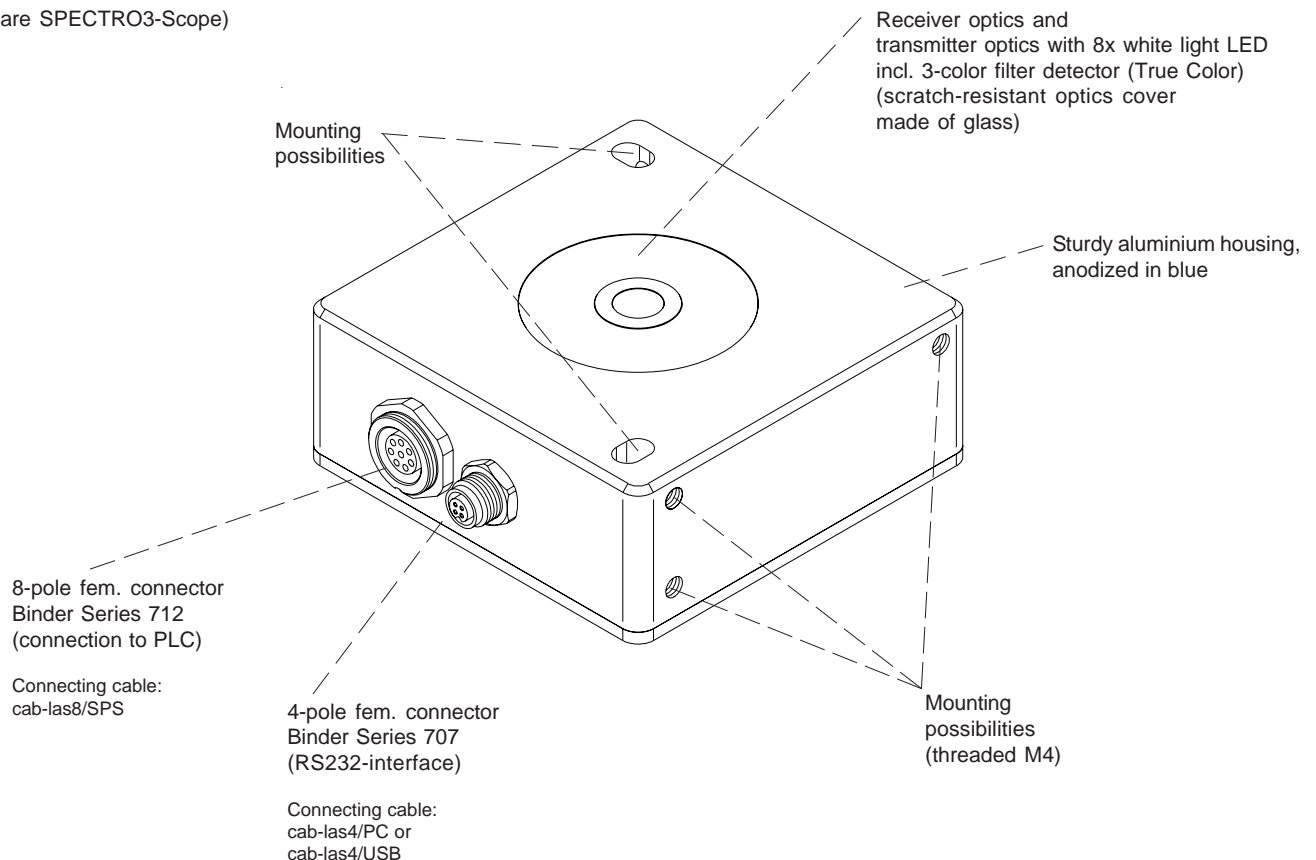



**Technical Data**

Model	SPECTRO-3-50-FCL-JR
Light source	8x super-bright white-light LED, focused AC-, DC-, or PULSE-operation (or OFF in case of luminous objects), can be switched under Windows®
Measuring range	typ. 10 mm ... 150 mm
Detection range	typ. 10 mm (at a distance of 20 mm) typ. 16 mm (at a distance of 50 mm) typ. 30 mm (at a distance of 80 mm) typ. 43 mm (at a distance of 110 mm) typ. 59 mm (at a distance of 140 mm)
Reproducibility	in the X, Y color range each 1 digit at 12-bit A/D conversion
Receiver	3-color filter detector (TRUE COLOR detector, "human color perception"), color filter curves acc. to CIE 1931
AC-/DC-/PULSE-operation	LED operation can be switched under Windows® by means of PC software SPECTRO3-Scope: AC operation: typ. up to 20 kHz (depends on the gain set: AMP1 ... AMP8) DC operation: typ. up to 35 kHz PULSE operation: typ. up to 5 kHz
Ambient light	up to 5000 Lux (in AC-mode and PULSE-mode)
Enclosure rating	IP67 (optics), IP64 (electronics)
Current consumption	< 220 mA
Interface	RS232, parameterisable under Windows®
Type of connector	connection to PLC: 8-pole fem. connector (Binder Series 712) connection to PC: 4-pole fem. connector (Binder Series 707)
Connecting cables	to PLC: cab-las8/SPS or cab-las8/SPS-w to PC/RS232 interface: cab-las4/PC or cab-las4/PC-w to PC/USB interface: or cab-las4/USB or cab-las4/USB-w
Housing material	aluminium, anodized in black
Housing dimensions	LxWxH approx. 65 mm x 65 mm x 26 mm (without flange connectors)
Operating temperature range	-20°C ... +55°C
Storage temperature range	-20°C ... +85°C
Pulse lengthening	adjustable under Windows® 0 ms ... 100 ms
Max. switching current	100 mA, short circuit proof
Switching frequency	max. 35 kHz (depends on the number of teach-colors and averaging value)
Outputs	OUT 0 ... OUT 4, digital (0V/+Ub), short-circuit protected, 100 mA max. switching current npn, pnp-output available (bright-, dark-switching can be switched over)
Averaging	over 32768 values max.
Voltage supply	+24VDC (± 10%), reversed polarity protected, overcurrent protected
Color memory capacity	non-volatile EEPROM with parameter sets for 31 colors max.
Temperature drift X,Y	$\Delta X/\Delta T$ ; $\Delta Y/\Delta T$ typ. 0,2 digits/°C (< 0,01% / °C)
Adjustment of gain	via step-switch: 8 steps (AMP1 ... AMP8), adjustable under Windows®
EMC test acc. to	DIN EN 60947-5-2

Dimensions

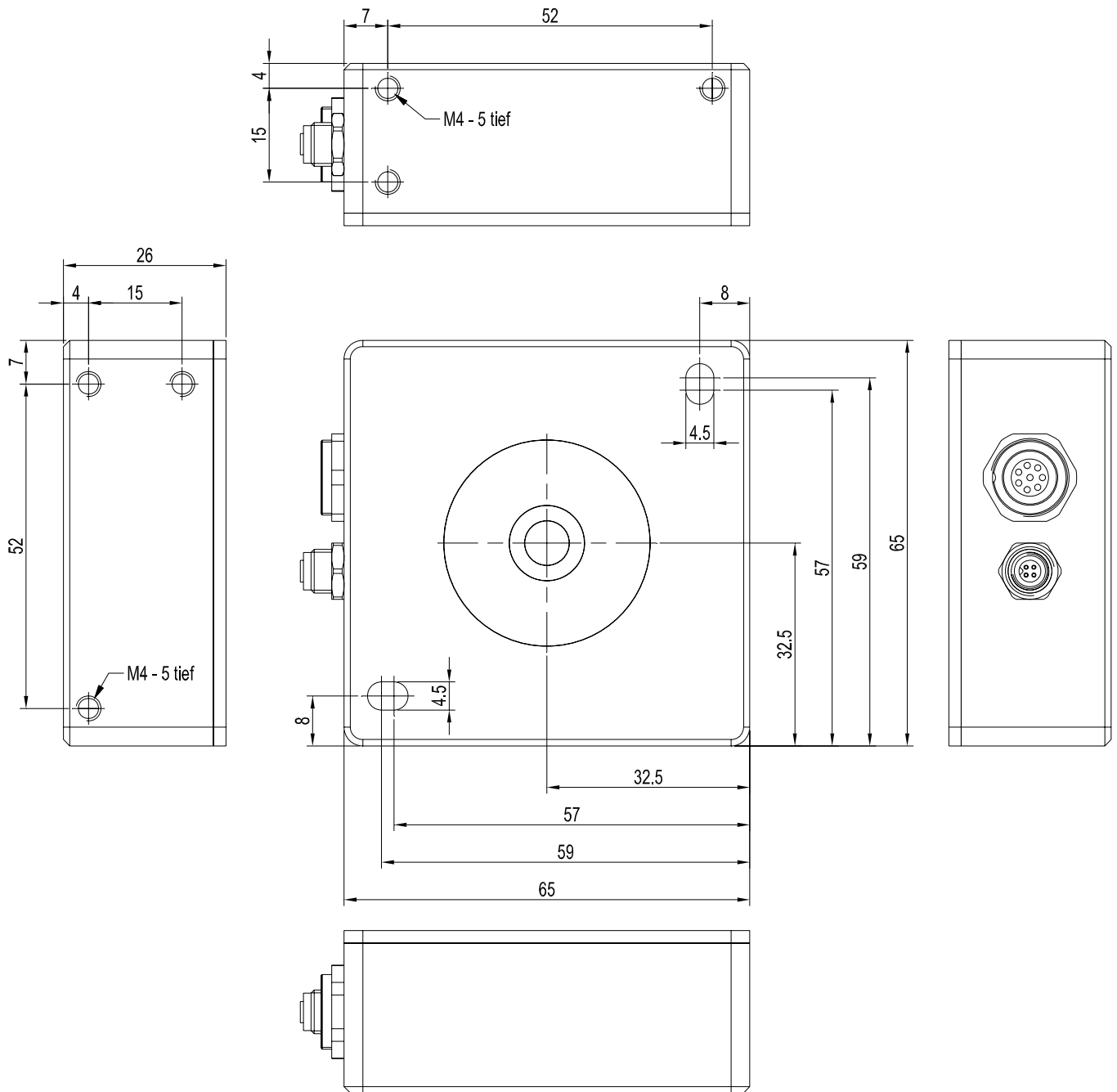

All dimensions in mm



**Connector Assignment**

**Connection to PLC:  
8-pole fem. connector Binder Series 712**

Pin:	Color:	Assignment:
1	white	GND (0V)
2	brown	+24VDC (±10%)
3	green	INO
4	yellow	OUT0
5	grey	OUT1
6	pink	OUT2
7	blue	OUT3
8	red	OUT4

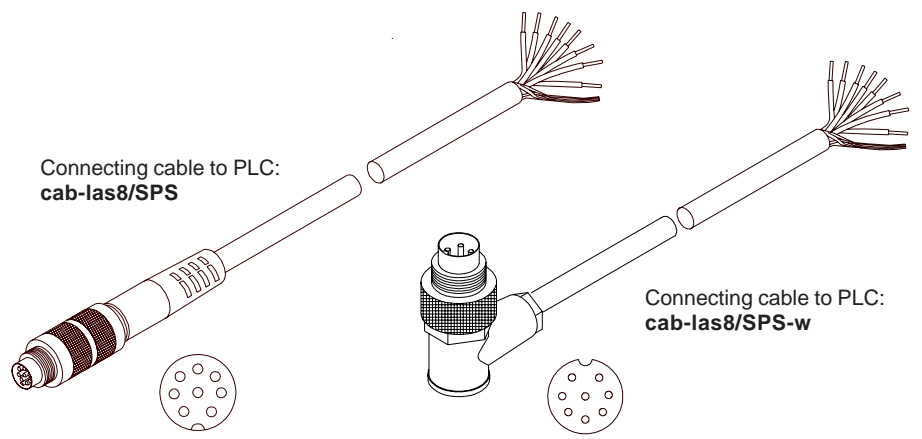
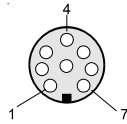

Connecting cable:  
cab-las8/SPS-(length)  
cab-las8/SPS-w-(length) (angle type, 90°)  
(Standard length 2m)

**Connection to PC:  
4-pole fem. connector Binder Series 707**

Pin:	Assignment:
1	+24VDC (+Ub, OUT)
2	GND (0V)
3	RxD
4	TxD

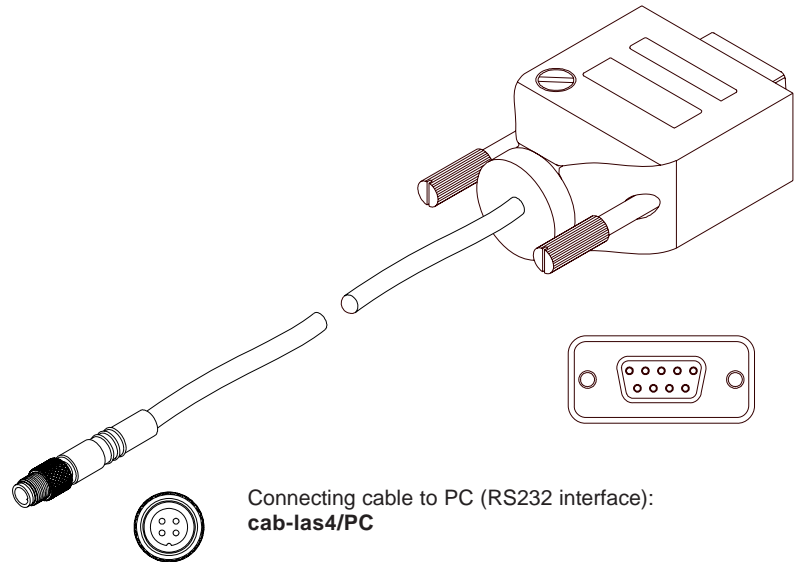

**Connection via RS232 interface at the PC:**  
Connecting cable:  
cab-las4/PC-(length)  
cab-las4/PC-w-(length) (angle type 90°)  
(Standard length 2m)

**alternative:**  
**Connection via USB interface at the PC:**  
Connecting cable (incl. driver software):  
cab-las4/USB-(length)  
cab-las4/USB-w-(length) (angle type 90°)  
(standard length 2m)

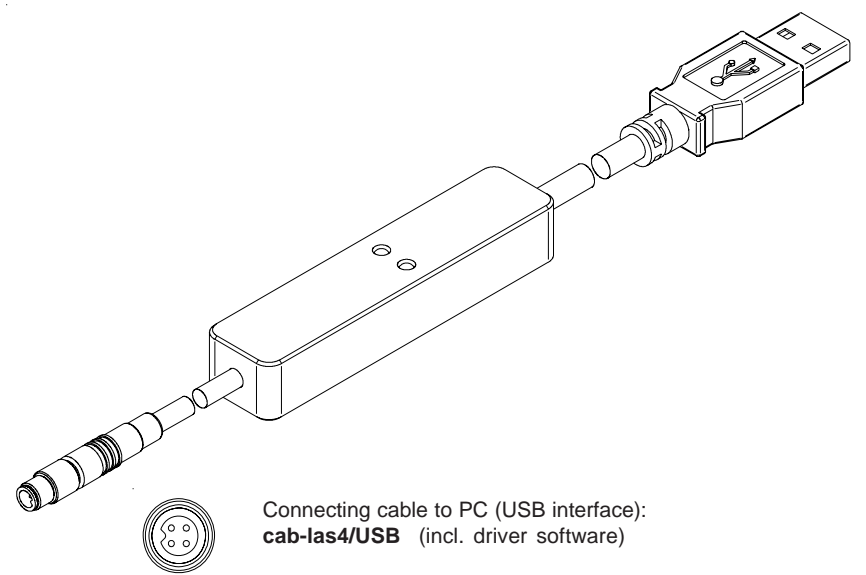

Connecting cable to PC (RS232 interface):  
**cab-las4/PC**

Connecting cable to PC (USB interface):  
**cab-las4/USB** (incl. driver software)



### Measuring principle of the color sensors of SPECTRO-3 series:

The SPECTRO-3 provides highly flexible signal acquisition. For example, the sensor can be operated in alternating-light mode (AC mode), which makes the sensor insensitive to extraneous light. It also can be set to constant-light mode (DC mode), which makes the sensor extremely fast and allows a scan-frequency of up to 35 kHz.

An OFF function turns off the integrated light source at the sensor and changes to DC operation. The sensor then can detect so-called "self-luminous objects". In PULSE operation extremely dark surfaces can be reliably detected. With the stepless adjustment of the integrated light source and the selectable gain of the receiver signal the sensor can be set to almost any surface or any "self-luminous object".

When the integrated light source of the SPECTRO-3 color sensor is activated, the sensor detects the radiation that is diffusely reflected from the object. As a light source the SPECTRO-3 color sensor uses a white-light LED with adjustable transmitter power. An integrated 3-fold receiver for the red, green, and blue content of the light that is reflected from the object, or the light that is emitted by a "self-luminous object", is used as a receiver. As mentioned above, a special feature here is that the gain of the receiver can be set in 8 steps. This makes it possible to optimally adjust the sensor to almost any surface and to different "self-luminous objects".

The SPECTRO-3 color sensor can be "taught" up to 31 colors. For each of these taught colors it is possible to set tolerances. In X/Y INT or s/i M mode these tolerances form a color cylinder in space. In X/Y/INT or s/i/M mode the tolerances form a color sphere in space. Color evaluation according to s/i M is based on the lab calculation method. All modes can be used in combination with several operating modes such as "FIRST HIT" and "BEST HIT". Raw data are represented with 12 bit resolution.

Color detection either operates continuously or is started through an external PLC trigger signal. The respective detected color either is provided as a binary code at the 5 digital outputs or can be sent directly to the outputs, if only up to 5 colors are to be detected. At the same time the detected color code is visualised by means of 5 LEDs at the housing of the SPECTRO-3. [\[Please note: Visualisation by means of LEDs not available with SPECTRO-3-...-JR types.\]](#)

With a TEACH button at the sensor housing the color sensor can be taught up to 31 colors. For this purpose the corresponding evaluation mode must be set with the software. The TEACH button is connected in parallel to the input IN0 (green wire at cable cab-las8/SPS). [\[Please note: TEACH button not available with SPECTRO-3-...-JR types.\]](#)

Parameters and measurement values can be exchanged between a PC and the SPECTRO-3 color sensor through the serial RS232 interface. All the parameters for color detection also can be saved to the non-volatile EEPROM of the SPECTRO-3 color sensor through this serial RS232 interface. When parameterisation is finished, the color sensor continues to operate with the current parameters in STAND-ALONE mode without a PC.

The sensors of the SPECTRO-3 series can be calibrated (white-light balancing). Balancing can be performed to any white surface. A ColorChecker™ table with 24 color fields is available as an alternative.

**Windows® user interface:**

The color sensor is parameterized under Windows® with the SPECTRO3-Scope software. The Windows® user interface facilitates the teach-in process at the color sensor and supports the operator in the task of adjustment and commissioning of the color sensor.

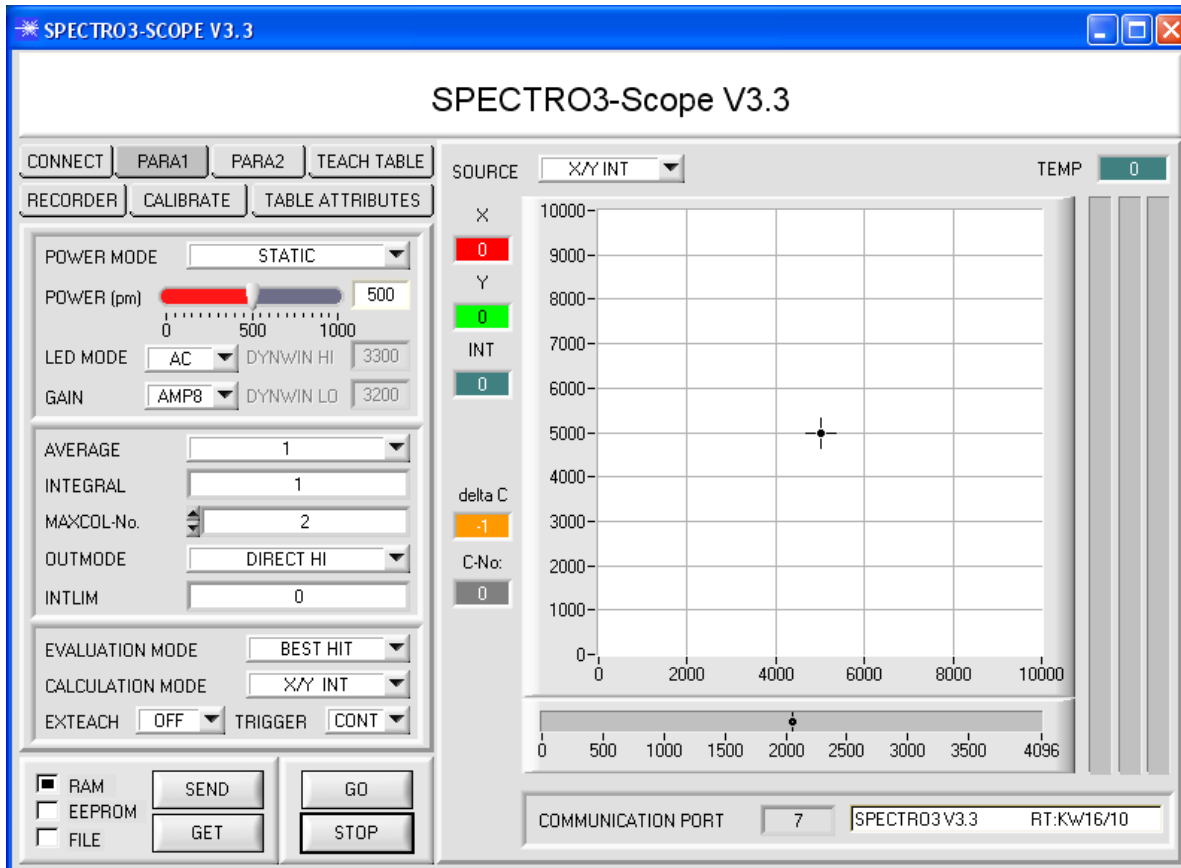

Under Windows® representation of the color value on a PC in numeric form and in a color chart, and representation of RGB values in a time chart. In addition the current RGB values are displayed as a bar chart.

The RS232 interface (tab PARA1 or PARA2) is used for setting parameters such as:

- POWER MODE: Light power of the LED
- LED MODE: Triggering of the internal light source
- GAIN: Used for setting the gain of the receiver
- AVERAGE: Averaging over a maximum of 32768 values
- INTEGRAL: This function field is used to set the number of scan values (measurement values) over which the raw signal measured at the receiver is summed up. This integral function allows the reliable detection even of extremely weak signals
- MAXCOL-No.: Number of colors to be checked
- OUTMODE: Triggering of the digital outputs
- INTLIM: Minimum intensity required for color evaluation
- EVALUATION MODE: Various evaluation modes to choose from (FIRST HIT, BEST HIT, MIN DIST, COL5)
- CALCULATION MODE: There are 2 methods of teaching a color. The CALCULATION MODE X/Y/INT (or s/i/M) uses a color sphere in space with radius TOL. Contrary to this, the CALCULATION MODE X/Y INT (or s/i M) uses a color cylinder in space with radius CTO or siTO and with height ITO or M.
- EXTEACH: In all the evaluation modes teaching of a color can be performed externally through IN0 or by means of the button at the sensor housing [Please note: TEACH button not available with SPECTRO-3-...-JR types.]
- TRIGGER: Continuous or external or self trigger

**Firmware Update**

**Firmware Update by means of the software Program Loader:**

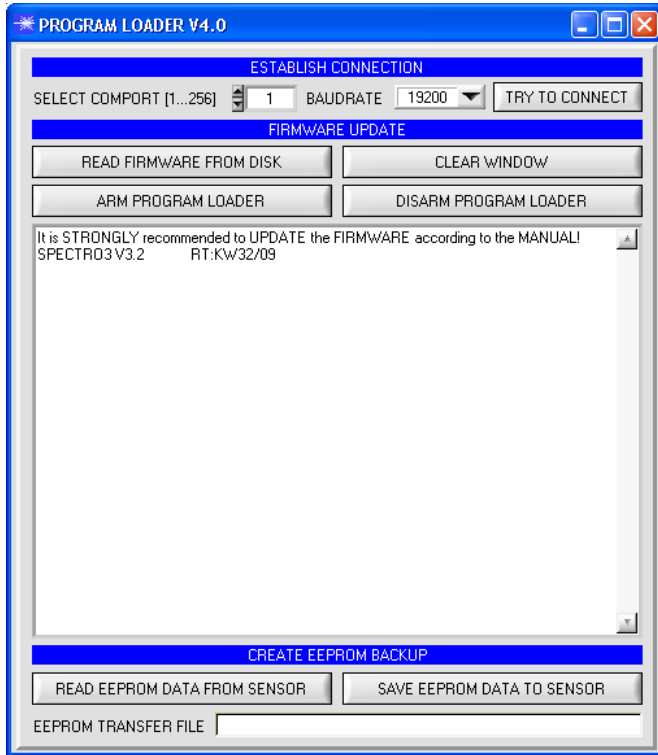

The software „Program Loader“ allows the user to perform an automatic firmware update. The update will be carried out through the RS232 interface.

An initialisation file (xxx.ini) and a firmware file (xxx.elf.S) are required for performing a firmware update. These files can be obtained from your supplier. In some cases an additional firmware file for the program memory (xxx.elf.p.S) is also needed, and this file will be automatically provided together with the other two files.

A plausibility check is performed after the initialisation file has been loaded with the Program Loader. If the initialisation file was changed or damaged, it will not be possible to perform a firmware update.

When the plausibility check is successfully completed, the instructions contained in the initialisation file will be carried out step by step.

The complete memory contents of the micro-controller in the sensor will be deleted in a firmware update. This means that both the program in the program memory and the data in the data memory will be lost.

The new firmware automatically writes the correct data to the program memory again.

However, the parameter settings, temperature curves, linearization curves, etc. that are stored in the data memory (EEPROM) will be deleted.

With the Program Loader V4.0 software the data will be saved in the EEPROM, and can be written back again after successful firmware update. For this purpose the software creates an EEPROM backup file.

**Diagrams**

**Half intensity width (detection range) d**

