

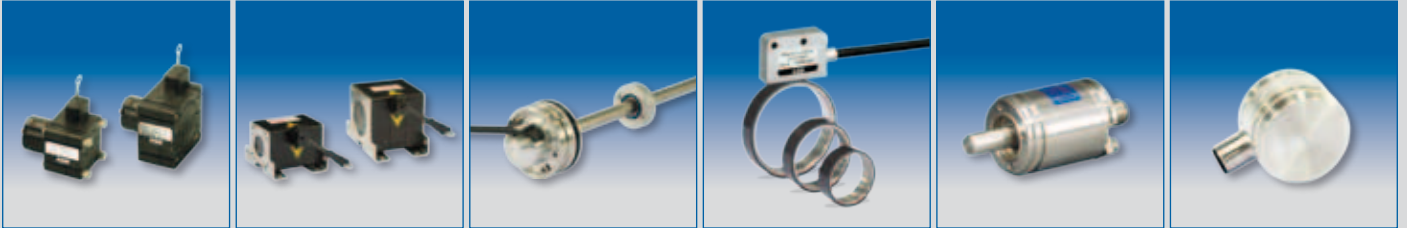

perfect in sensors.



Cable Extension Sensors

Tape Extension Sensors NEWS

**Magnetostrictive
Position Sensors**

Magnetic Angle Sensors

MEMS Inclination Sensors

Magnetic Encoders

2013

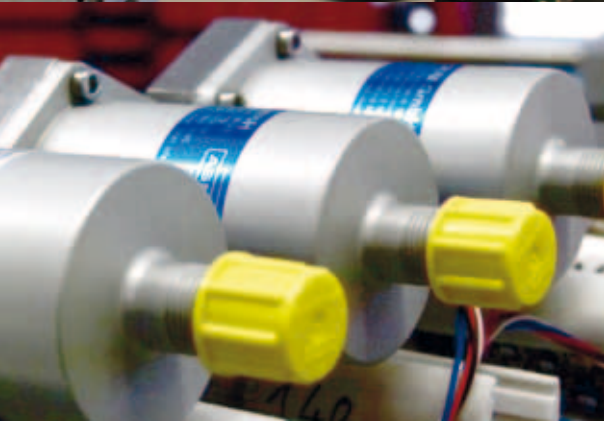
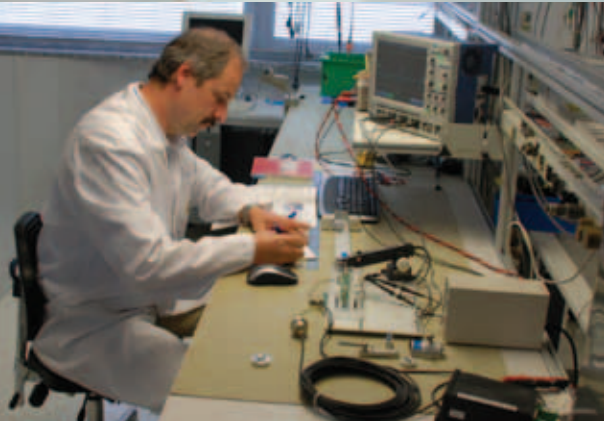

Your Partner for Position Sensors

ASM is a worldwide leading manufacturer of innovative sensor solutions. Based on over 30 years of experience in the development and manufacturing of position sensors, the company offers superior quality solutions for industrial applications and research using the latest technologies.

All from one source: displacement, angle, inclination

With six innovative product lines, ASM offers a comprehensive product program including sensor solutions for displacement, angle, and inclination measurement, which is unparalleled on the sensors market.

Latest technologies for your sensing needs

ASM's product program comprises various technologies and offers perfect solutions for manifold applications.

ASM products stand for precision and reliability

ASM position sensors have always been a synonym for superior quality ensuring consistent productivity and smooth operations. The quality management certified according to DIN EN ISO 9001:2008 and continuous research and development in company-own laboratories guarantee these high quality standards.

ASM – Your partner worldwide

Headquartered in Germany, ASM maintains a worldwide presence through a strategic network of subsidiaries and more than 50 distributors. Being present all over the world, the company ensures closeness to local market needs and quick product and service availability.



POSIWIRE®

Robust. Compact. Reliable.



POSIWIRE® cable extension position sensors capture linear position either absolutely or incrementally using a measuring cable made from stainless steel. Due to their robustness, easy and space-saving installation and the availability of measuring lengths up to 60,000 mm, POSIWIRE® position sensors are the standard solution for many applications.

Advantages at a glance

- Fast and easy installation
- Compact design
- Resistant to vibration and shock
- High protection class up to IP68/IP69K
- Linearity up to 0.01%
- Measuring lengths up to 60,000 mm
- Numerous output types

Applications

POSIWIRE® position sensors are used in applications where linear movements of elements have to be exactly positioned. The sensors assure reliable operation in many sectors of automation and processing, as well as in the field of industry and research, e.g. in material handling systems, elevators, hoist and conveyor technologies, and are as well suited for medical equipment and wind power plants.

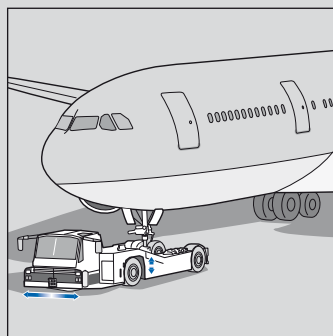

Aircraft tractors

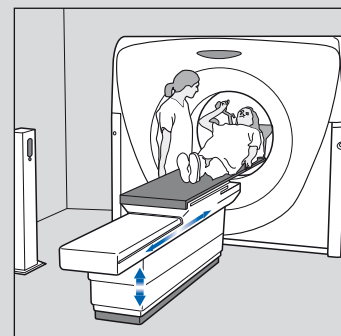

Magnetic resonance scanners

Cable Extension Sensors

The functional principle

The POSIWIRE® sensor operates by attaching the measurement cable from the sensor directly to the moving object. The measurement cable is coiled onto a cable drum that is under constant spring tension. The unwinding process from the drum converts the linear movement of the measuring cable into an angular movement which is then captured by angle sensor elements (encoders or potentiometers) and converted into an electrical output signal. Subsequent signal conditioners convert the signal of the sensing element into voltage (0...10 Volt), current, (4...20 mA), or digital pulses (SSI) suitable for standard interfaces.

A detailed product catalog for POSIWIRE® position sensors is available.

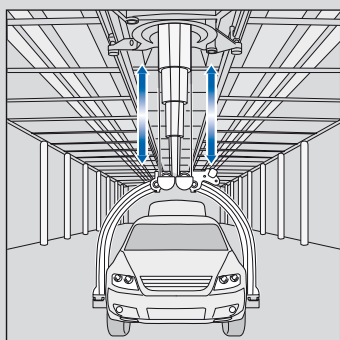
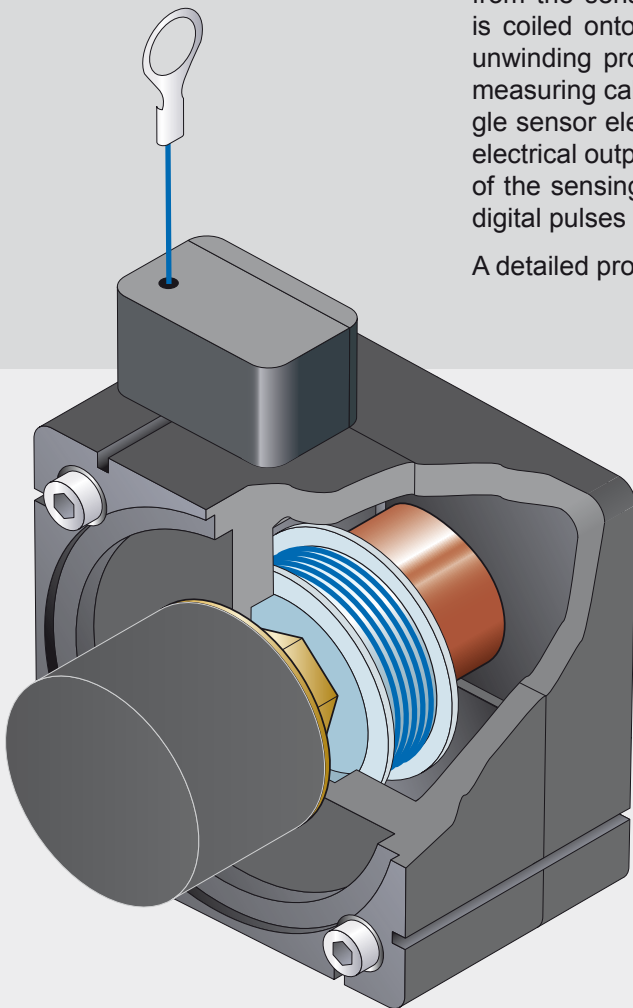

Overhead monorails

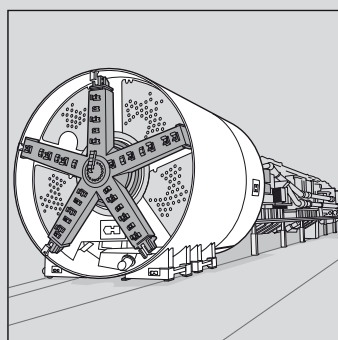

Tunneling machines

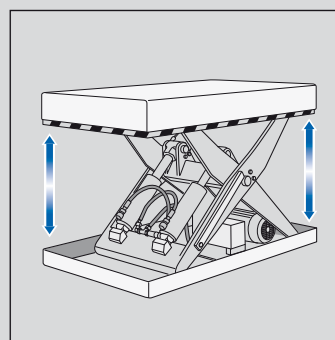

Scissors lift tables

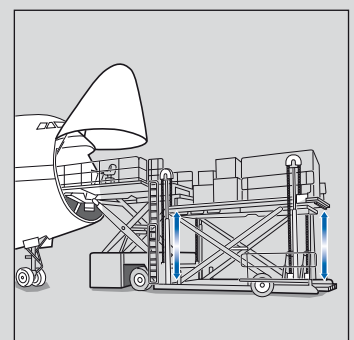

Cargo loaders

POSIWIRE®

WS® Position Sensors

Selection Guide

Selection features		Model									
		WS31(C) / WS42(C)		WS10SG		WS10ZG / WS10		WS17KT	WS58C	WS19KT	
Sensing device		P	E	P	E	P	E	P	E	E	
Measurement range 0 to ... [mm]											
100				●		●					
125				●		●					
250		●		●		●					
375				●		●					
500		●	●	●		●					
750		●		●		●					
1,000		●	●	●		●					
1,250				●	●	●	●				
1,500								●			
2,000								●		●	
2,500								●	●		
3,000								●		●	
3,500											
4,000								●			
5,000								●		●	
6,000											
6,250								●			
7,500											
8,000										●	
10,000								●			
12,500								●			
15,000								●		●	
20,000											
25,000											
30,000											
40,000											
60,000											
Analog outputs, absolute											
Potentiometer 1 kΩ/10 kΩ		●		●		●		●			
Voltage 0 ... 10 V		● ³⁾		●		●		●			
Current 4 ... 20 mA		●		●		●		●			
PMUV/PMUI 0 ... 10 V/4 ... 20 mA				●		●		●			
Incremental outputs TTL/HTL/RS422											
Incremental encoder			●		●		●			●	
Digital outputs, absolute											
SSI				● ¹⁾		● ¹⁾		● ¹⁾	●	●	
Profibus									●	●	
CAN / CANopen				● ²⁾		● ²⁾		● ²⁾	●	●	
DeviceNet									●	●	
Interbus									●	●	
Linearity standard		±0.35%	±0.20%	±0.10%	±0.05%	±0.10%	±0.05%	±0.10%	±0.05%	±0.05%	
optional		–	–	±0.05%	–	±0.05%	–	±0.05%	±0.01%	±0.01%	
Protection class standard		IP50		IP65		IP65		IP64	IP50	IP64	
optional		–		–		–		IP66	IP64	–	
Explosion protection											
Dust-Ex proof		–	–	–	–	–	–	–	–	–	

WS31C and WS42C also available without housing
 Sensing device: P = Potentiometer E = Encoder
 ● = standard; ○ = optional; – = not available;

¹⁾ = A/D converted SSI output 16 bit (optional 12 or 14 bit)
²⁾ = A/D converted CANopen bus 16 Bit
³⁾ = 0.5 ... 10 V

WS7.5		WS60	WS12		WS10EX	WS12EX	WS100M	Model	Selection features
P	E	E	P	E	P	P	P		
								Sensing device	
								Measurement range 0 to ... [mm]	
								100	
								125	
								250	
								375	
								500	
								750	
								1,000	
								1,250	
								1,500	
								2,000	
								2,500	
								3,000	
								3,500	
								4,000	
								5,000	
								6,000	
								6,250	
								7,500	
								8,000	
								10,000	
								12,500	
								15,000	
								20,000	
								25,000	
								30,000	
								40,000	
								60,000	
								Analog outputs, absolute	
								Potentiometer 1 kΩ/10 kΩ	
								Voltage 0 ... 10 V	
								Current 4 ... 20 mA	
								PMUV/PMUI 0 ... 10V/4 ... 20 mA	
								Incremental outputs TTL/HTL/RS422	
								Incremental encoder	
								Digital outputs, absolute	
								SSI	
								Profibus	
								CAN / CANopen	
								DeviceNet	
								Interbus	
								Linearity standard	
								optional	
								Protection class standard	
								optional	
								Explosion protection	
								Dust-Ex Proof	

POSITAPE®

Very robust. Ideal for pulley applications.

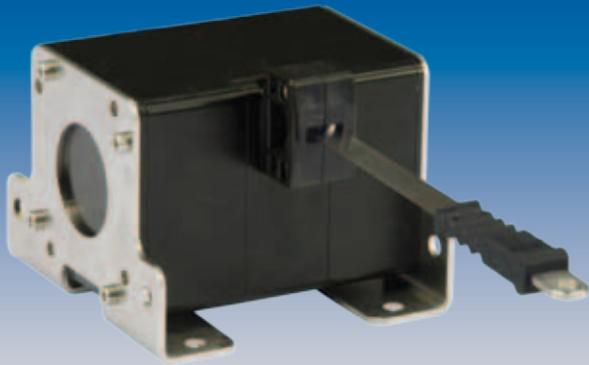

POSITAPE® position sensors utilize the functional principle of the POSIWIRE® position sensors. Instead of using a cable, POSIWIRE® position sensors are constructed with a specially designed stainless steel tape. This high-tech robust stainless steel tape has a nearly unlimited life cycle. Thus, POSITAPE® position sensors are perfectly suited in applications that require pulleys due to the tight locations where the sensor must be installed. The rugged design is shock and vibration resistant and makes POSITAPE® position sensors suitable for use in harsh environmental conditions.

Advantages at a glance

- Nearly unlimited life cycle of the measuring tape
- Extremely robust against dirt
- Narrow axial design
- Low wear
- High linearity due to electronic linearization (up to 0.05%)
- Measurement ranges up to 20,000 mm
- Integrated dust wiper

Applications

Due to the robust stainless steel tape POSITAPE® position sensors are perfectly suited for pulley applications, as well as for use in hostile environments, e.g. in the sector of mobile working machines. POSITAPE® position sensors can also be used in applications in which the absence of particles is required due to hygienic regulations, like in the food processing industry or pharmaceutical industry.

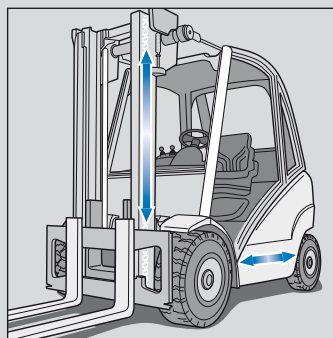

Forklifts

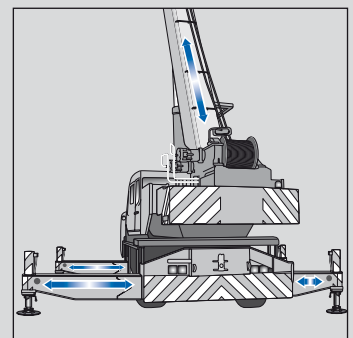

Mobile cranes

Tape Extension Sensors

The functional principle

The POSITAPE® sensor operates by attaching the measurement tape from the sensor directly to the moving object. The measurement tape is coiled onto a cable drum that is under constant spring tension. The unwinding process from the drum converts the linear movement of the measuring tape into an angular movement which is then captured using angle sensor elements (encoders or potentiometers) and converted into an electrical output signal. Subsequent signal conditioners convert the signal of the sensing element into voltage (0,5 ...10 V), current, (4...20 mA), or digital pulses (SSI) suitable for standard interfaces.

A detailed product catalog for POSITAPE® position sensors is available.

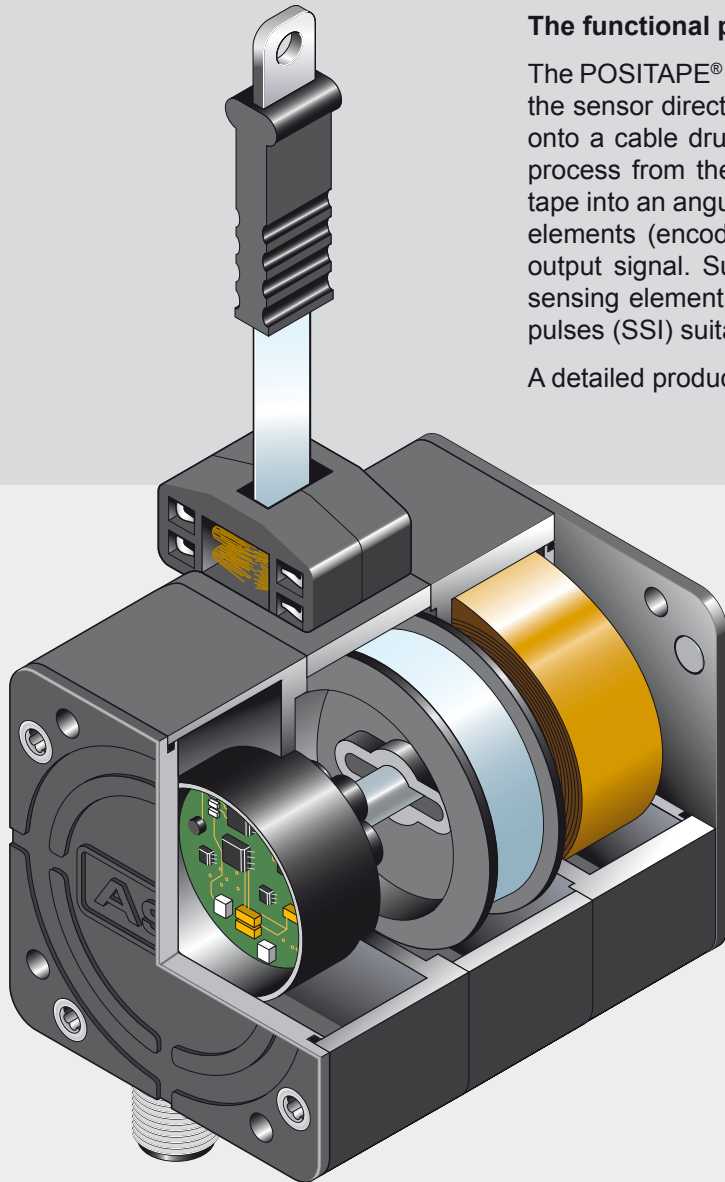

NEW

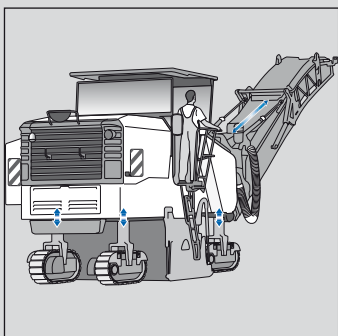

Cold milling machines

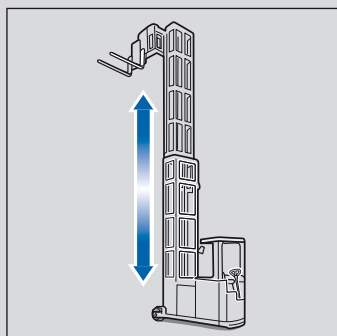

High-rack forklifts

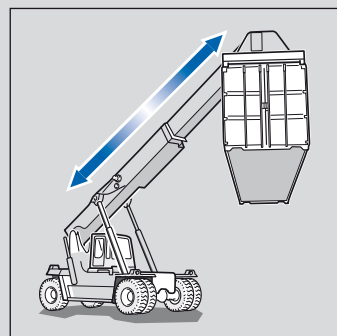

Material handling equipment

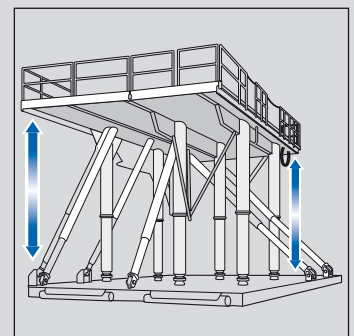



Lifting platforms



POSITAPE®

WB® Position Sensors

Selection Guide

Model	Selection features		
	 WB10ZG	 WB61	 WB85
Measurement range 0 to ... [mm]			
250	●		
375	●		
500	●		
750	●		
1.000	●		
1.250	●		
1.500	●	●	
2.000	●	●	
2.500		●	
3.000		●	
3.500		●	
4.000		●	
5.000			●
6.000			●
7.500			
8.000			
10.000			
12.500			
15.000			
17.500			
20.000			
Analog outputs, absolute			
Voltage 0,5 ... 10 V	●	●	●
Voltage 0,5 ... 4,5 V	●	●	●
Current 4 ... 20 mA	●	●	●
Redundant version (optional)		●	●
Digital outputs, absolute			
SSI	●	●	●
CANopen	●	●	●
CAN SAE J1939	●	●	●
Linearity			
standard	±0,10 %	±0,10 %	±0,10 %
optional (for meas. ranges ≥ 1000 mm)	±0,05 %	±0,05 %	±0,05 %
Protection class			
standard	IP65	IP67	IP67
optional	–	IP67/IP69K*	IP67/IP69K*

* = with a suitable IP67/IP69K connector

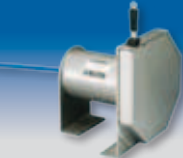
  			Model	Selection features
WB21	WB12	WB100M		
				Measurement range 0 to ... [mm]
				250
				375
	•			500
	•			750
	•			1.000
	•			1.250
	•			1.500
	•	•		2.000
	•			2.500
	•			3.000
	•	•		3.500
	•			4.000
				5.000
				6.000
		•		7.500
•				8.000
•		•		10.000
•				12.500
•				15.000
•				17.500
•				20.000
				Analog outputs, absolute
•	•	•		Voltage 0,5 ... 10 V
•	•	•		Voltage 0,5 ... 4,5 V
•	•	•		Current 4 ... 20 mA
•	•	•		Redundant version (optional)
				Digital outputs, absolute
•	•	•		SSI
•	•	•		CANopen
•	•	•		CAN SAE J1939
				Linearity
±0,10 %	±0,10 %	±0,10 %		standard
±0,05 %	±0,05 %	±0,05 %	(for meas. ranges ≥ 1000 mm)	optional
				Protection class
IP67	IP67	IP68/IP69K		standard
IP67/IP69K*	IP67/IP69K*	–		optional

* = with a suitable IP67/IP69K connector

POSICHRON®

Non-contact. Fits various installation conditions.

POSICHRON® is an absolute, non-contact and wear-free position measuring system. The key feature of POSICHRON® measuring system is its extreme robustness. Therefore POSICHRON® sensors are best suited for applications where other measuring principles would fail. The availability of various constructions – rod, square profile and ultra flat profile – means that the system can be adapted to suit all kinds of installation conditions.

Advantages at a glance

- Wear- and maintenance-free
- Resistant to dirt, humidity and dust
- Protection class up to IP68/IP69K
- Highly resistant to vibration and shock
- Linearity up to $\pm 0.02\%$ f.s.
- Measurement ranges up to 5,750 mm

Applications

POSICHRON® position sensors can be applied universally. The application range comprises e.g. hydraulic cylinders and presses, liquid level measurement, injection molding machines, dosing and mixing systems, die-casting machines, road vehicle tests, tunneling machines, wind power plants und patient beds.

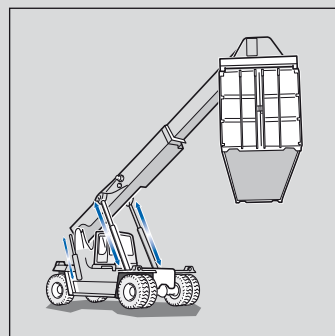

Material handling vehicles

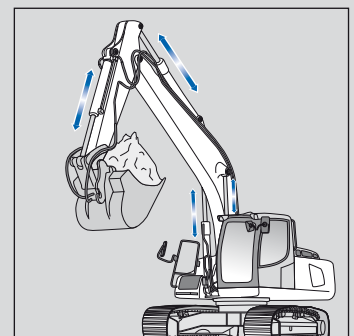

Hydraulic excavators

Magnetostrictive Sensors

The functional principle

POSICHRON® position sensors consist of a magnetostrictive wave guide and a non-contact position magnet. To determine the position, a current impulse is sent through the wave guide. This current impulse generates a circular magnetic field which propagates around the wave guide. If this circular magnetic field makes contact with the magnetic field of the movable position magnet, a tensional mechanical-elastic density wave is generated as a result of magnetostriction. A detector in the sensor head detects the arrival of this reflected density wave. The position is determined by measuring the time difference between the electrical induction current impulse and the mechanical-elastic density wave generated by the magnet (time-of-flight-principle).

A detailed product catalog for POSICHRON® position sensors is available.

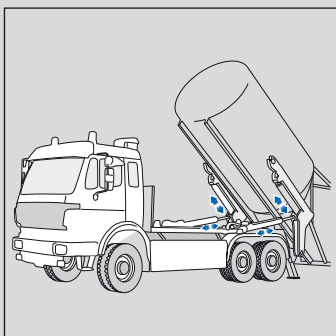
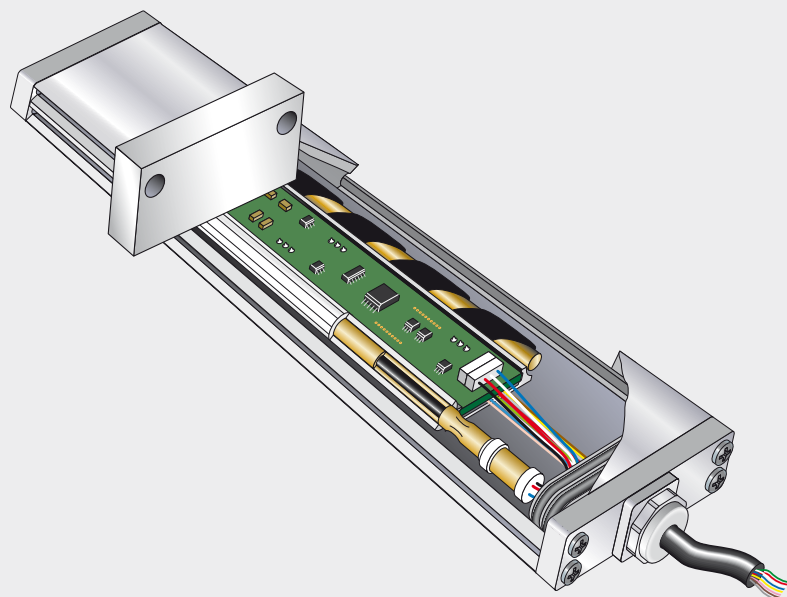

Commercial vehicles

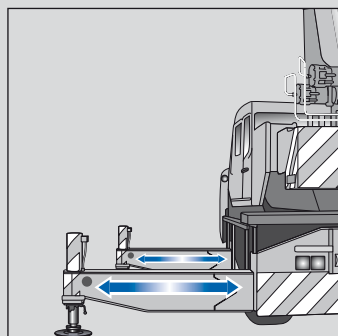



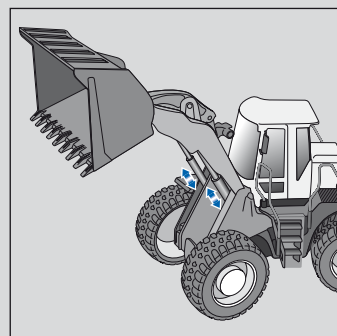

Mobile crane outriggers

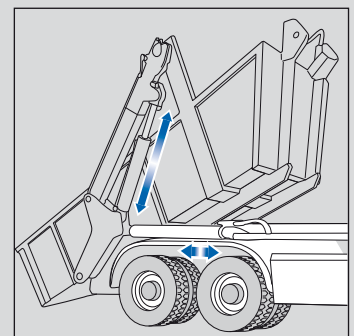

Wheel loaders



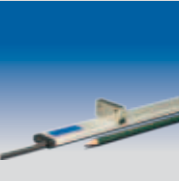

Skip loaders

Model					
Selection features	PCQA22	PCQA24	PCFP23	PCFP24	PCFP25
Measurement range					
100 ... 5,750 mm	●	●	●	●	●
Analog outputs¹⁾					
0.5 ... 10 V 0.5 ... 4.5 V 4 ... 20 mA	●	●	●	●	●
Digital outputs					
SSI	●	●	●	●	●
CANopen	●	●	●	●	●
CAN SAE J1939	●	●	●	●	●
Protection class					
Standard	IP64	IP67	IP64	IP67	IP64
optional	–	IP67/IP69K*	–	IP67/IP69K*	IP67

¹⁾ = 1 or 2 position magnets;
Position und velocity
scalable (PMU)

* = with a suitable IP67/IP69K connector

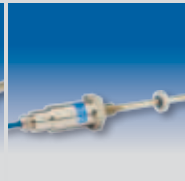
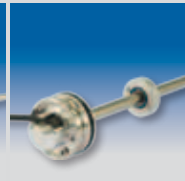
    					Model	Selection features
PCRP21	PCRP32	PCST24	PCST27	PCST25		
					Measurement range	
•	•	•	•	•		100 ... 5.750 mm
					Analog outputs¹⁾	
•	•	•	•	•		0.5 ... 10 V 0.5 ... 4.5 V 4 ... 20 mA
					Digital outputs	
•	•	•	•	•		SSI
•		•	•	•		CANopen
•	•	•	•	•		CAN SAE J1939
					Protection class	
IP64	IP68/IP69K	IP67	IP68/IP69K	IP67		Standard
–	–	IP67/IP69K*	–	IP67/IP69K		optional

¹⁾ = 1 or 2 position magnets;
Position und velocity
scalable (PMU)

* = with a suitable IP67/IP69K connector

POSIMAG®

Non-contact. High resolution.

POSIMAG® is a non-contact, high resolution magnetic position measuring system for measuring lengths of up to approx. 30 meters. Because of its sturdiness and resistance to dirt, together with the system's exceptional resistance to wear and tear, POSIMAG® is also suitable for use under challenging environmental conditions.

Advantages at a glance

- Non-contact and wear-free
- Resistant to dirt
- Shielded metal housing
- Simple installation and adjustment
- Standard quadrature encoder interface
- Protection class up to IP67
- Measuring ranges up to 30,000 mm



Applications

POSIMAG® position sensors are suitable for linear position measurement in many industrial applications in the production of machinery, plants and precision equipment, in which sturdiness and wear-free design play a crucial role, like e.g. in material handling systems. The POSIROT® product family was developed for similar types of rotary positioning applications.

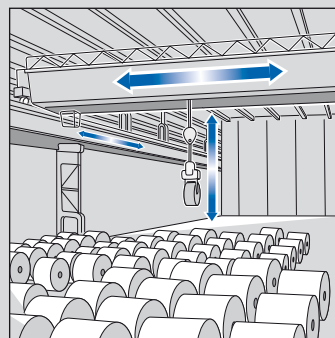

Overhead cranes

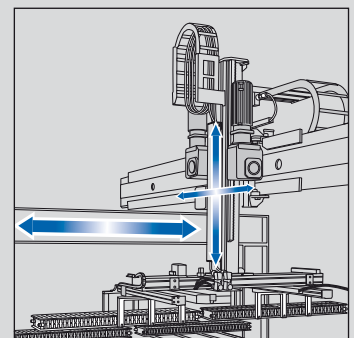

Handling systems

Magnetic Scale Sensors

The functional principle

POSIMAG® consists of a magnetic measuring strip and a non-contact magneto-resistive scanning head. The magnetic measuring strip is periodically magnetized with magnetic north and south poles. To capture a position the magneto-resistive sensor head samples sinusoidal magnetic fields above the magnetic measuring. Standard Resolutions up to 1 µm are available. The signals can be processed by all common industrial control units with suitable signal processing speeds, or displayed directly using a digital display unit from ASM's PRODIS® series.

A detailed product catalog for POSIMAG® position sensors is available.

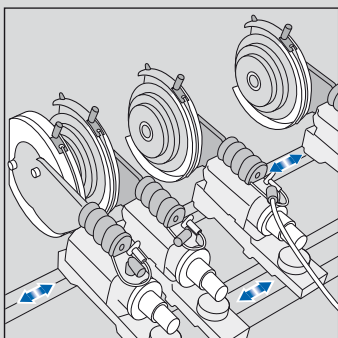
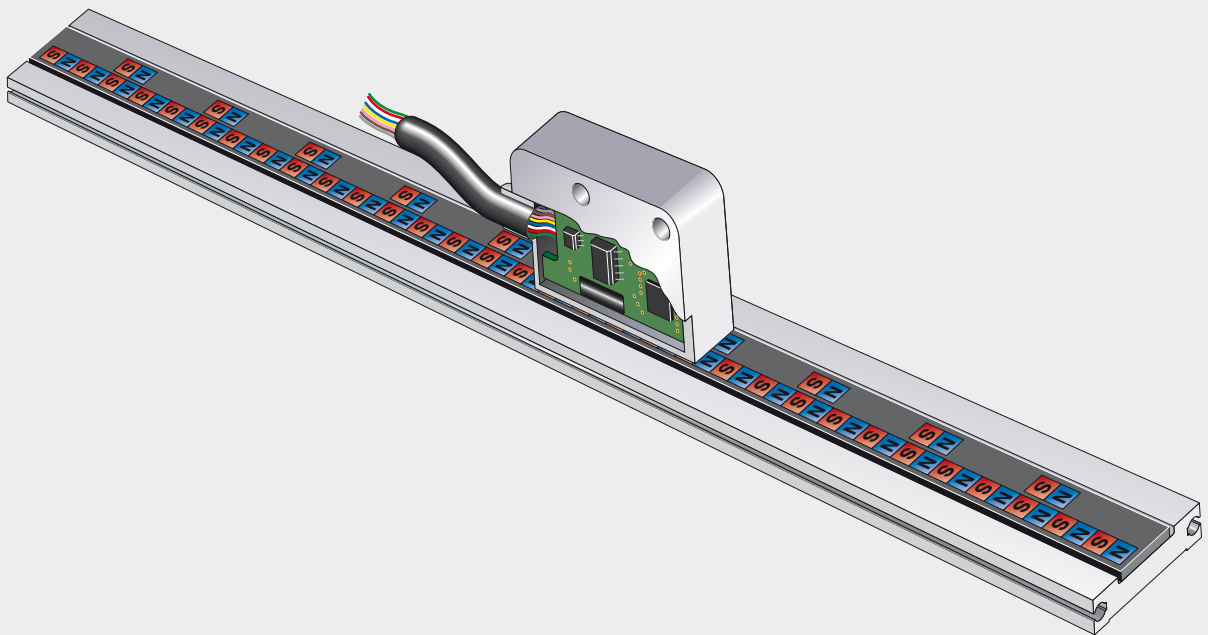

Slitter winders

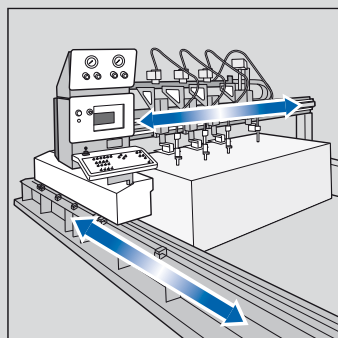

Flame cutting machines

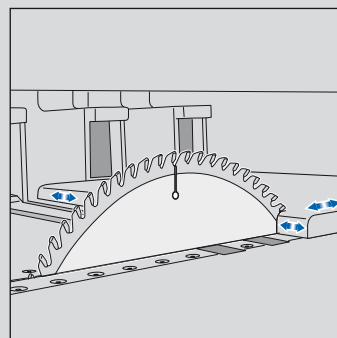

Dimensioning saws

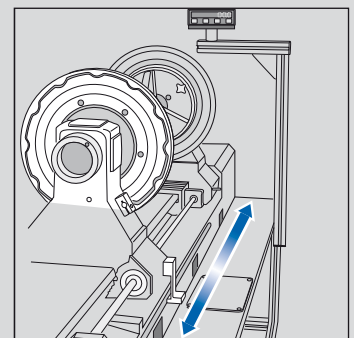

Special-purpose lathes

Magnetic measuring scale and free floating unguided sensor head

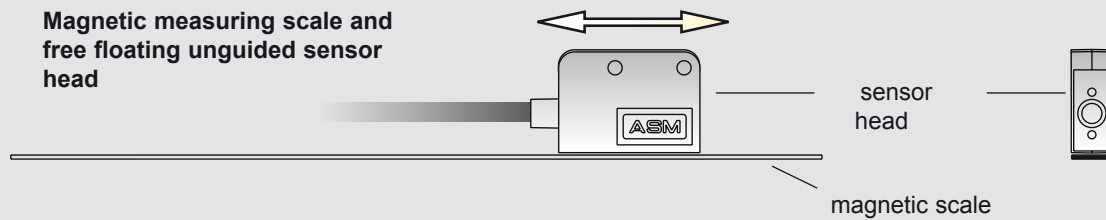

For direct adhesive taping – the cost-effective mounting method.

Magnetic measuring scale in flat profile and unguided sensor head

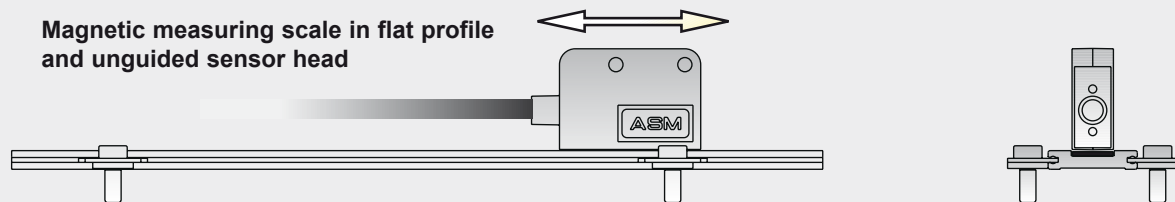

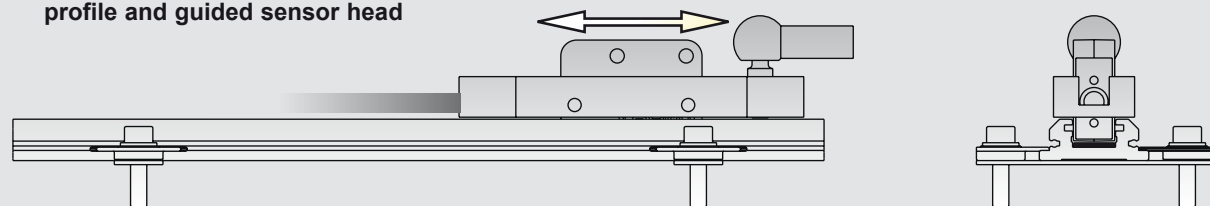

Easy to mount.
Adjustment on site possible.
Can be stacked by 3 m units up to 30 m length.

Magnetic measuring scale in guidance profile and guided sensor head

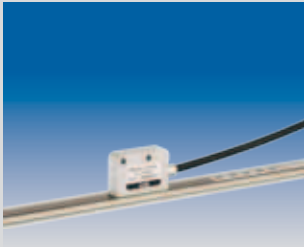

Provides integral linear guidance for applications without own linear guidance by system.

Model						
	Magnetic scale		Flat profile		High profile	
Measurement range	0 ... 30,000 mm		0 ... 30,000 mm		0 ... 30,000 mm	
Magnetic period	2 mm	5 mm	2 mm	5 mm	2 mm	5 mm
Resolution	up to 1 µm	up to 2.5 µm	up to 1 µm	up to 2.5 µm	up to 1 µm	up to 2.5 µm
Digital outputs, incremental						
HTL	•	•	•	•	•	•
TTL	•	•	•	•	•	•
TTL24V	•	•	•	•	•	•
Linearity	15 µm ±40 µm/m	30 µm ±40 µm/m	15 µm ±40 µm/m	30 µm ±40 µm/m	15 µm ±40 µm/m	30 µm ±40 µm/m
Protection class	IP67		IP67		IP67	

POSIROT®

Magnetic. Flexible. Suitable for outdoor use.

POSIROT® angle sensors are absolute, rotary position sensors utilizing a non-contact position magnet. Due to their extraordinary resistance to shock, vibration and dirt, POSIROT® position sensors are best suited especially for outdoor applications in hostile environments, being even superior to optical encoders. Various designs from flat housing to M12 housing in stainless steel allow easy adaptation for numerous applications.

Advantages at a glance

- Measurement range 0° to 360°
- Magnetic measurement principle
- Non-contact or with 10 mm shaft
- Resistant to vibration, shock and dirt
- Protection class up to IP68/IP69K

Applications

Due to their outstanding sturdiness POSIROT® angle sensors are well suited for the rotary position measurement in applications with harsh environmental conditions, such as those found on mobile working machines, vessels, cranes, excavators, and also on wind power plants and medical equipment.

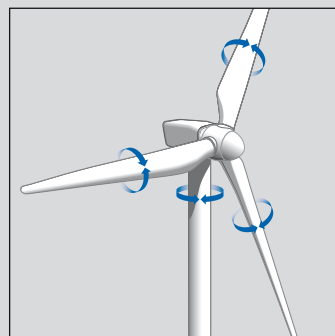

Wind power plants

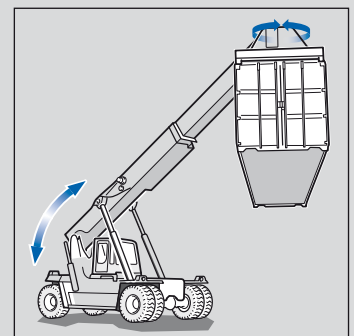

Material handling vehicles

Magnetic Angle Sensors

The functional principle

POSIROT® angle sensors provide an absolute rotary position by utilizing a multiple Hall-Effect sensor array and a position magnet.

A detailed product catalog for POSIROT® angle sensors is available.

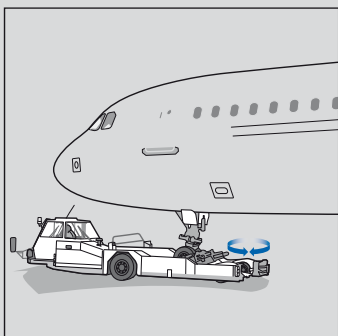
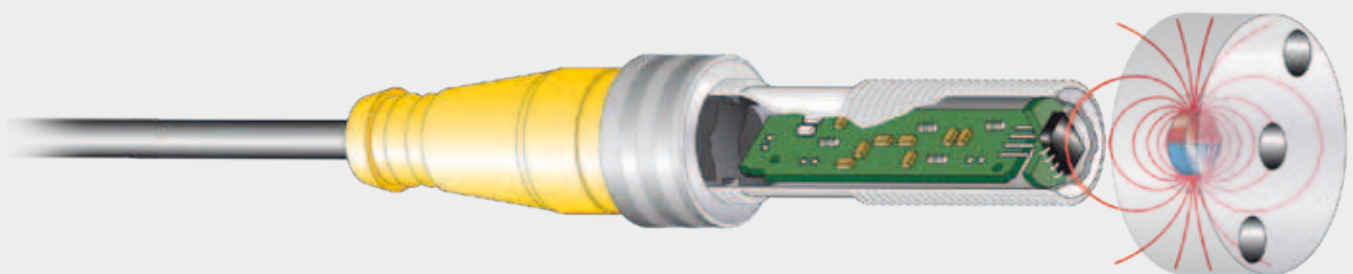

Aircraft tractors

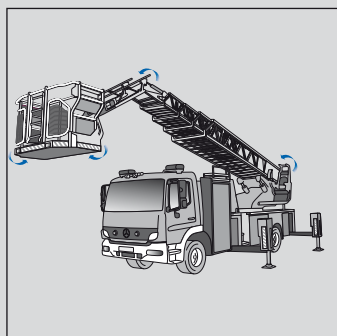



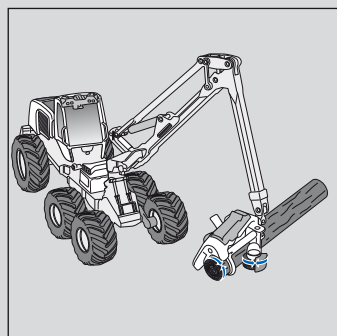

Turnable ladder vehicles

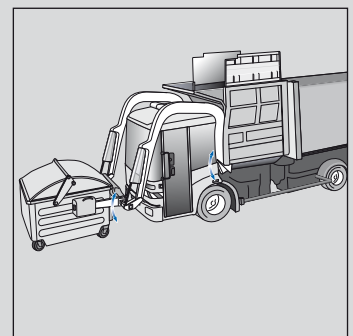

Harvesters

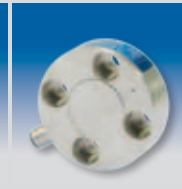

Communal vehicles

Model Selection features												
	PRAS20	PRAS21	PRAS27	PRDS27	PRAS1	PRDS1	PRAS2	PRDS2	PRAS3	PRDS3	PRAS5	PRDS5
Measurement range	A	A	A	D	A	D	A	D	A	D	A	D
0°... 360°	•	•	•	•	•	•	•	•	•	•	•	•
Analog outputs, absolute												
Voltage 0.5 ... 10 V	•		•		•		•		•		•	
Voltage 0.5 ... 4.5 V	•	•	•		•		•		•		•	
Current 4 ... 20 mA	•		•		•		•		•		•	
Redundant Version (optional)	•		•				•		•		•	
Digital outputs, absolute												
SSI - RSSI5V, RSSI24V						•		•		•		•
CANopen				•				•		•		•
CAN SAE J1939				•				•		•		•
Digital outputs, incremental												
RS5V, RS24V						•		•		•		•
RS5VF, RS24VF								•		•		•
HT24V						•		•		•		•
HT24VF								•		•		•
Linearity (standard)	±0.5%		±0.5%	±1°	±0.3%	±1°	±0.3%	±1°	±0.3%	±1°	±0.3%	±1°
Protection class												
Standard	IP60		IP67		IP67		IP67		IP67		IP67/IP69K	
optional	–		–		IP67/IP69K*		IP67/IP69K*		IP67/IP69K*		IP68/IP69K*	

A = Analog output

D = Digital output

* = with a suitable IP67/IP69K connector

Selection features	Model		Model	
	PMIS4/PMIR5		PMIS4/PMIR7(N)	
Measurement range				
0°... 360°	•	•	•	•
Digital outputs, incremental				
HTL	•	•	•	•
TTL	•	•	•	•
TTL24V	•	•	•	•
Linearity (standard)	±0.1°	±0.1°	±0.1°	±0.1°
Protection class	IP67		IP67	

POSIROT®

**Angle Sensors, Dust-Ex-Proof
Selection Guide**

Selection features	Model		
	PRAS2EX	PRAS3EX	PRAS5EX
Measurement range	A	A	A
0°... 360°	•	•	•
Analog outputs, absolute			
Voltage 0.5 ... 10 V	•	•	•
Voltage 0.5 ... 4.5 V	•	•	•
Current 4 ... 20 mA	•	•	•
Linearity (standard)	±0.3%	±0.3%	±0.3%
Protection class	IP65	IP65	IP65

A = Analog output

POSITILT®

Micromechanical. Very robust. Wear-free.

POSITILT® inclination sensors measure inclination between 0 and $\pm 180^\circ$ in a non-contact, wear-free and absolute way. Utilizing the MEMS technology, these sensors are extremely resistant to shock, vibration and dirt, and are therefore well suited for outdoor applications. Various sensor enclosure designs open possibilities for many different types of applications.



Advantages at a glance

- Wear-free
- High resolution
- Measurement range $\pm 180^\circ$
- Protection class up to IP68/IP69K
- Resistant to shock and vibration
- MEMS technology
- Measurement with 1 or 2 axes

Applications

POSITILT® inclination sensors are the ideal solution for determining inclination position in harsh applications such as solar power plants, commercial vehicles, transportation, and are best suited for industrial applications in which inclination position has to be precisely measured, monitored and continuously adjusted.

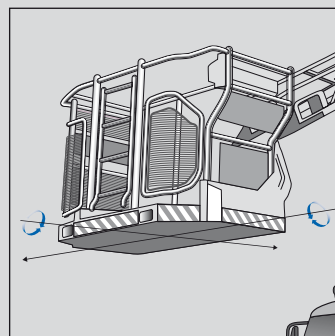

Turnable ladder vehicles

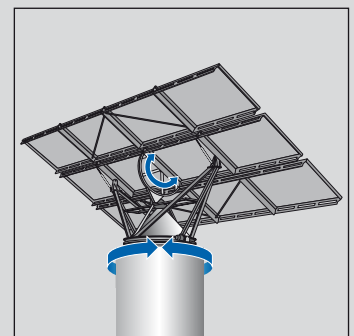

Photovoltaic modules

MEMS Inclinasion Sensors

The functional principle

POSITILT® inclination sensors work using micro electro mechanical systems. They utilize the typical spring-mass systems which measure the deflection of small proof masses (seismic masses) in a dependant relationship to the position. They are capacitive accelerometers– in this case acceleration systems with differential capacitors. The signal processing circuit of the two sensing capacitors forms a capacitive voltage divider which determines the position and allows linearization or compensation.

Subsequent signal conditioners convert the signal of the sensing element into voltage 0.5 ... 10 Volt, current 4 ... 20 mA. A digital CAN-Bus output is also available.

A detailed product catalog for POSITILT® inclination sensors is available.

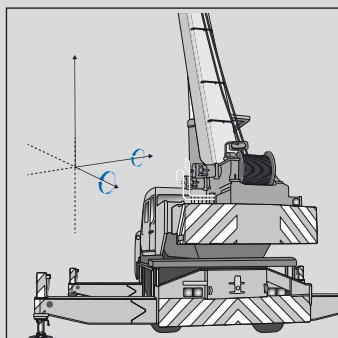
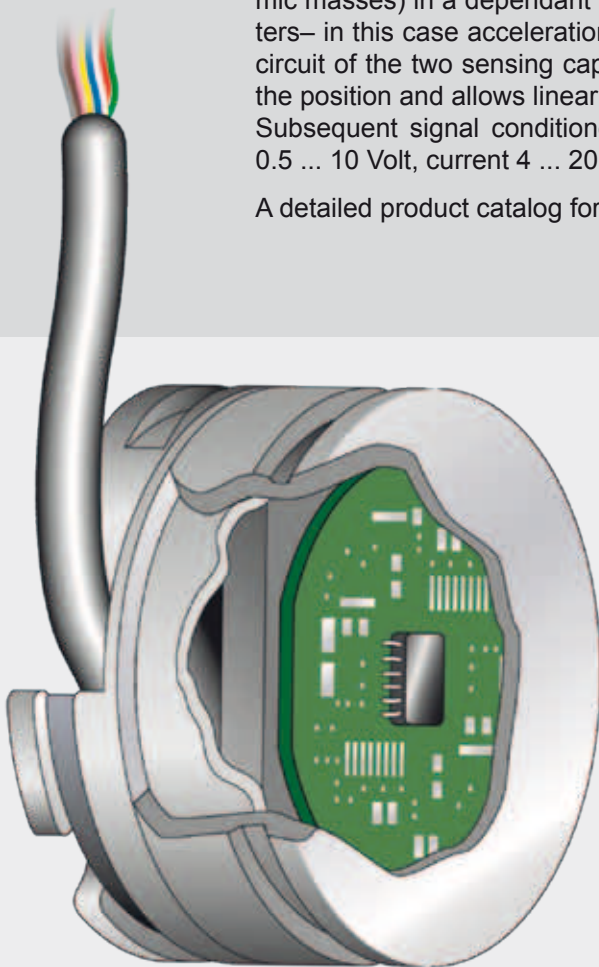

Mobile cranes

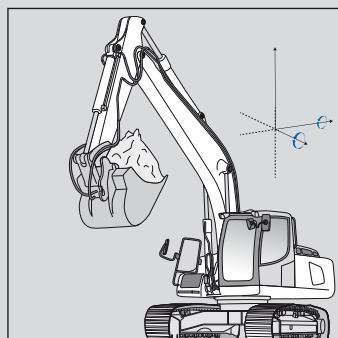

Excavators

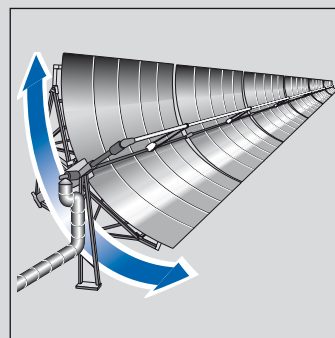

Thermal solar collectors

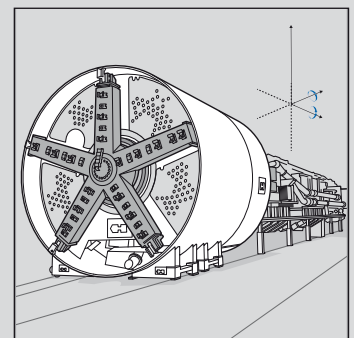

Tunneling machines

POSITILT®

POSITILT® Inclination Sensors MEMS Technology

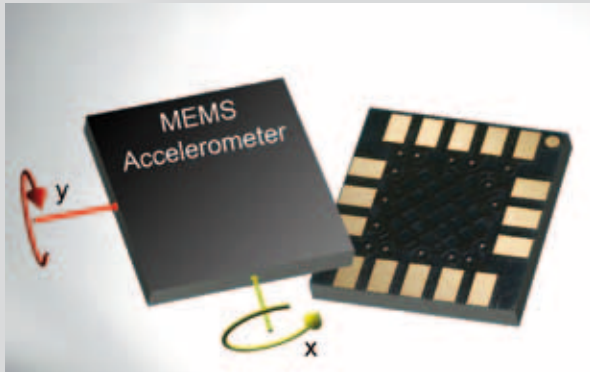

POSITILT® inclination sensors utilize the MEMS technology (MEMS = **M**icro **E**lectro **M**echanical **S**ystems). MEMS sensors contain mechanical components like springs, wafers, proof masses (seismic masses) or membranes of fine-structured crystal silicon. Also materials like metals, ceramic, plastic and many others are used. Physical parameters like pressure, acceleration, rotation rate, and flow quantity or gas structure are measured precisely and reliably.

Volume micro-machined systems and surface micro-machined systems are distinguished. The volume micro-machined systems are constructed as a combination of silicon wafers or silicon wafers with glass wafers, whereas the surface micro-machined systems mostly use production methods, which are also employed in semiconductor and IC industry. Apart from the typical thin film method, molding, etching and vertical structuring of silicon are used as a production method.

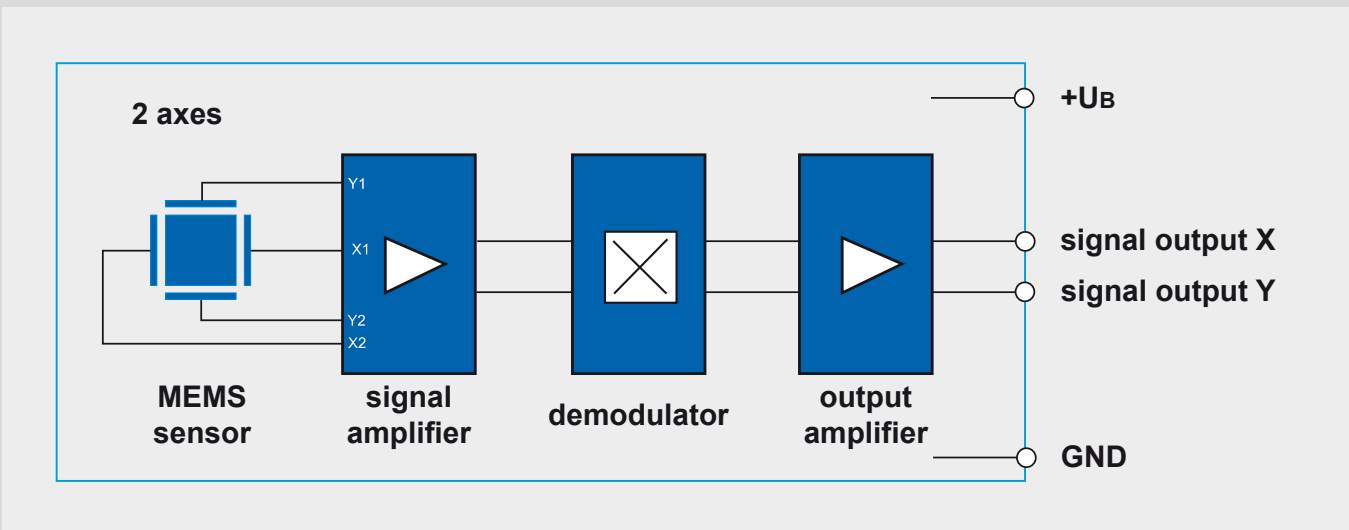

Integrated electronic circuits process the subtle sensor signals and relay them via analog or digital interfaces to the processing control devices.

Selection features	Model		Model		Model		Model	
	PTAM27	PTDM27	PTAM2	PTDM2	PTAM5	PTDM5	PTAM2EX	PTAM5EX
Measurement range	A	D	A	D	A	D	A	A
1 axis ±180°	•	•	•	•	•	•	•	•
2 axes ±60°		•		•		•	•	•
2 axes ±180°	•		•		•			
Analog outputs, absolute								
Voltage 0.5 ... 10 V	•		•		•		•	•
Voltage 0.5 ... 4.5 V	•		•		•		•	•
Current 4 ... 20 mA	•		•		•		•	•
Digital outputs, absolute								
CANopen		•		•		•		
CAN SAE J1939		•		•		•		
Linearity (standard)	±0.5°		±0.5°		±0.5°		±0.5°	±0.5°
Protection class								
Standard	IP67		IP67		IP67/IP69K*		IP65	IP65
optional	–		IP67/IP69K*		IP68/IP69K		–	–

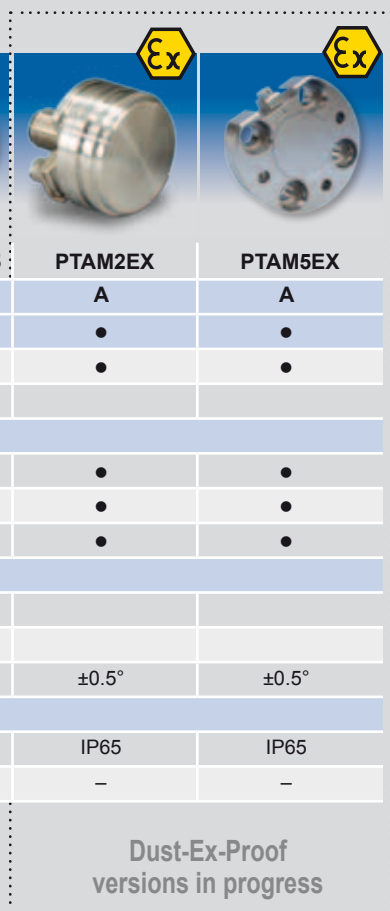

εx

εx

Dust-Ex-Proof versions in progress

A = Analog output D = Digital output
 * = with a suitable IP67/IP69K connector

Application examples for Tape Extension Position Sensors of the POSITAPE® product family

Application in material handling equipment

The requirements for material handling equipment are high. The continuous hoisting and moving of empty or fully loaded containers requires the highest precision and stability of all built-in vehicle components. Fixed limitations posed for lifting and ascending functions must be exactly observed and reliably measurable.

Tape Extension Position Sensors of the ASM's POSITAPE® product family have been designed for Heavy Duty applications. Due to their extraordinary robustness they reliably perform their tasks even under very rough environmental conditions.

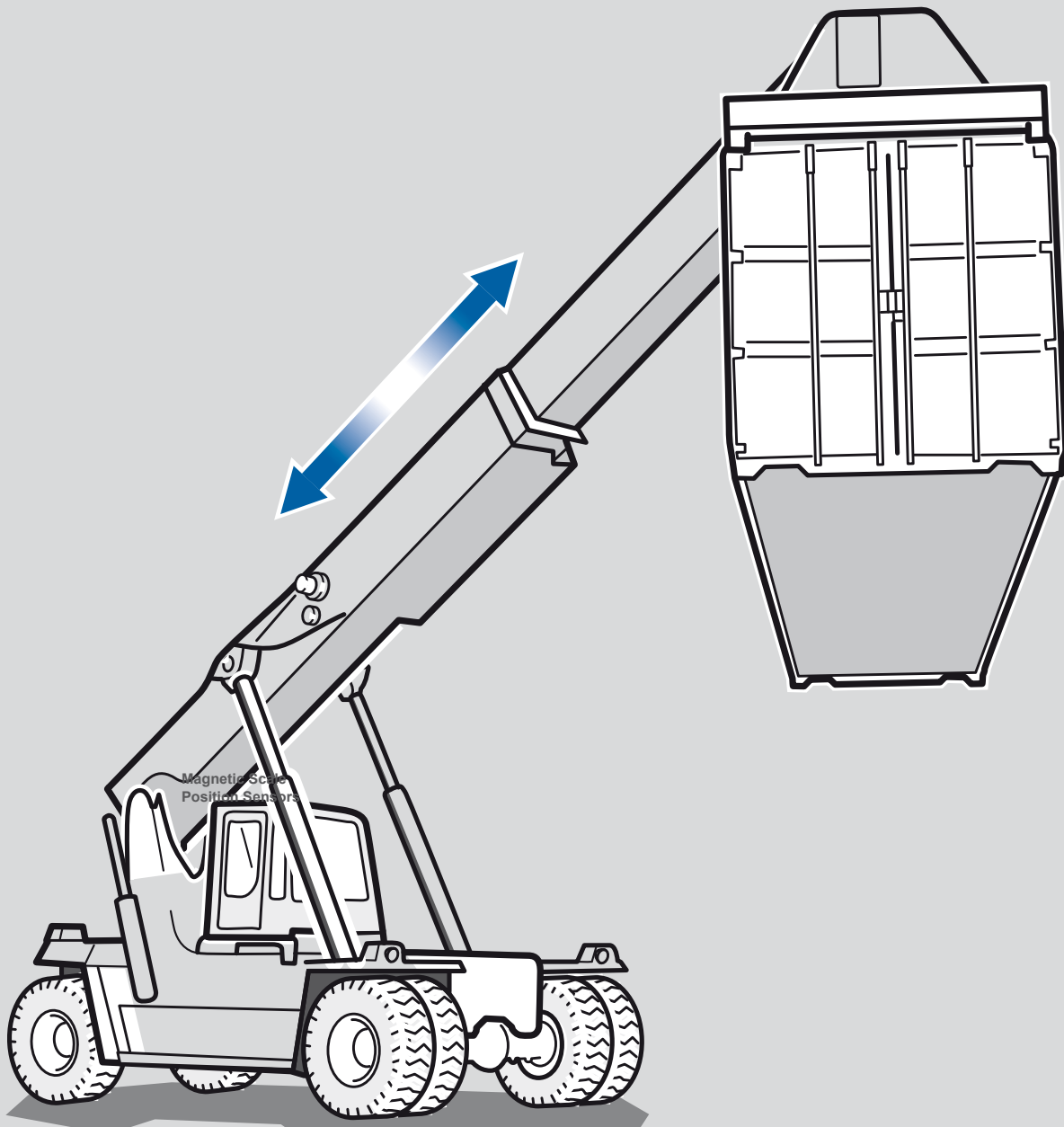

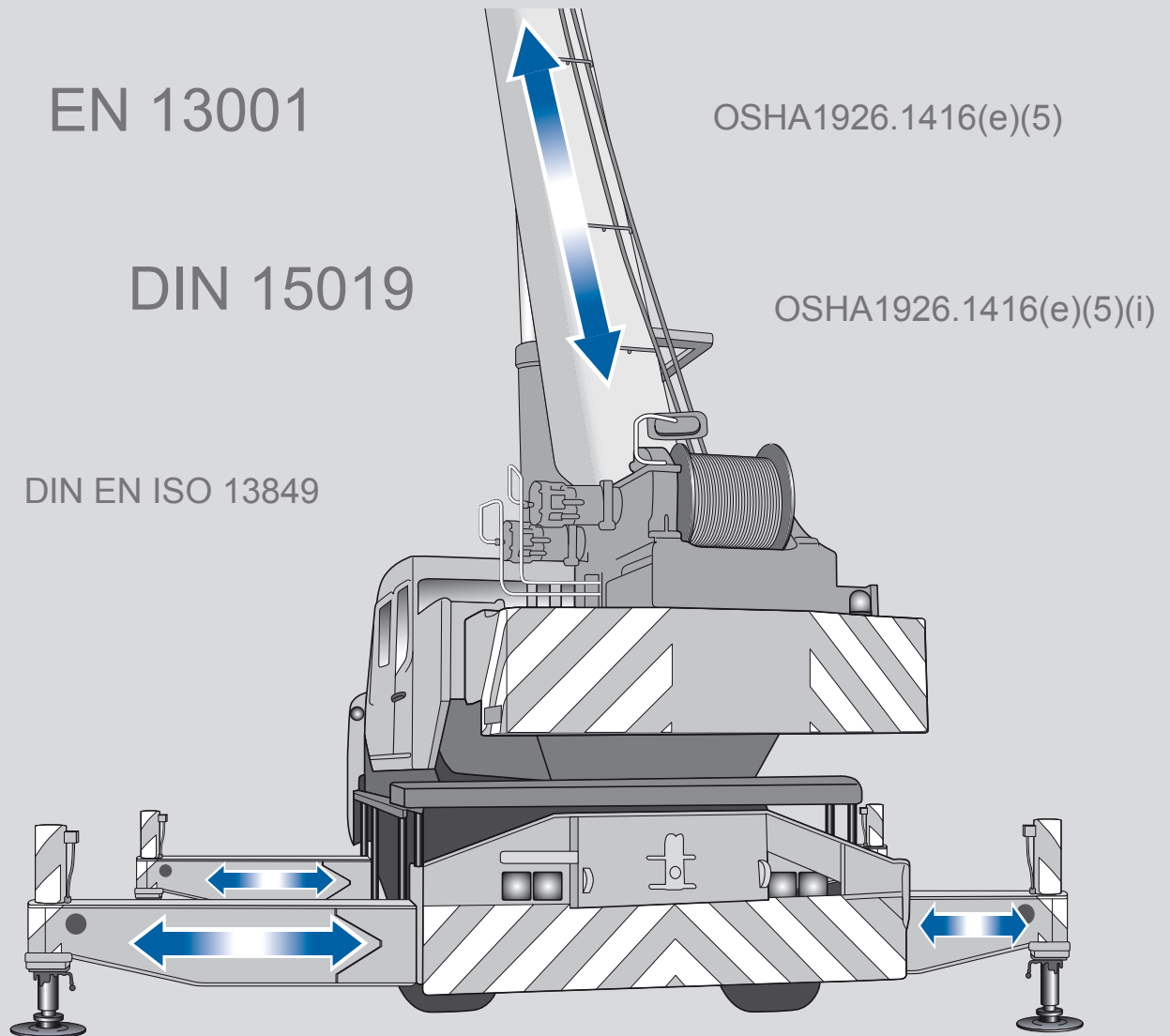



DIN EN 12999

Application in outriggers

The accurate positioning of the outriggers of a mobile crane is crucial for the safety of crane operations. Limited installation conditions in cranes require compact sensor solutions.

POSITAPE® Position Sensors made by ASM are the right choice for adoption of the safety standards for mobile cranes.

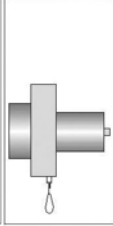
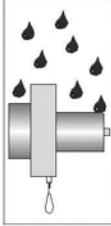
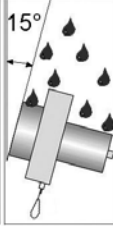
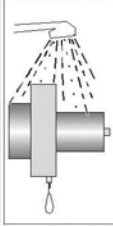
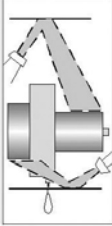
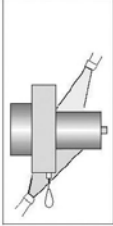
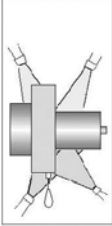
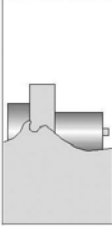
Protection Class According to EN 60529

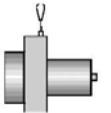
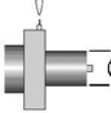
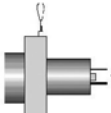
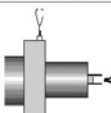
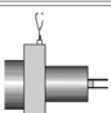
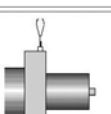
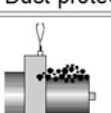
2 nd char. numeral: Protection against ingress of water 1 st char. numeral: Protection against solid foreign objects									
Protection against ...	Non protected	Falling water drops vertical / 15°	Spraying water	Splashing water	Water jets	Powerful water jets	Temporary immersion	Continuous Immersion	
EN 60529	IP .. 0	IP .. 1	IP .. 2	IP .. 3	IP .. 4	IP .. 5	IP .. 6	IP .. 8	
 IP 0 .. Non protected	IP 00								
 IP 1 .. Solid foreign objects diameter ≥ 50 mm	IP 10	IP 11	IP 12						
 IP 2 .. Solid foreign objects diameter ≥ 12,5 mm	IP 20	IP 21	IP 22	IP 23					
 IP 3 .. Solid foreign objects diameter ≥ 2,5 mm	IP 30	IP 31	IP 32	IP 33	IP 34				
 IP 4 .. Solid foreign objects diameter ≥ 1 mm	IP 40	IP 41	IP 42	IP 43	IP 44				
 IP 5 .. Dust-protected	IP 50		IP 52	IP 53	IP 54	IP 55	IP 56		
 IP 6 .. Dust-tight	IP 60				IP 64	IP 65	IP 66	IP 67	IP 68

* Depth and duration of immersion must be specified!

IP69K - Water at high pressure / steam jet cleaning
 Note: IP67 / IP69K does not include IP68

Contact Us



Do you have questions regarding ASM products? Would you like to receive detailed product information sent to you or do you wish to discuss sensor solutions for your application directly with us? We are happy to assist and are looking forward to your inquiry.

You can contact us by phone, e-mail or fax request. (for contact information see back cover)



Visit our website:

www.asm-sensor.com



perfect in sensors.

The information presented in this catalog does not form part of any quotation or contract, is believed to be accurate and reliable and may be changed without notice. No liability will be accepted by ASM for any consequence of its use.

Publication thereof does not convey nor imply any license under patent or industrial or intellectual property rights.

Applications that are described herein for any of these products are for illustrative purpose only. ASM makes no representation or warranty that such applications will be suitable for the specified use without further testing or modification.



ASM GmbH

Am Bleichbach 18 - 22
85452 Moosinning

Deutschland

Tel. +49-8123-986-0
Fax +49-8123-986-500
info@asm-sensor.com
www.asm-sensor.com