

A SEP/P SEP/D SEP

A SEP Controller P SEP Controller D SEP Controller

Instruction Manual Sixth Edition

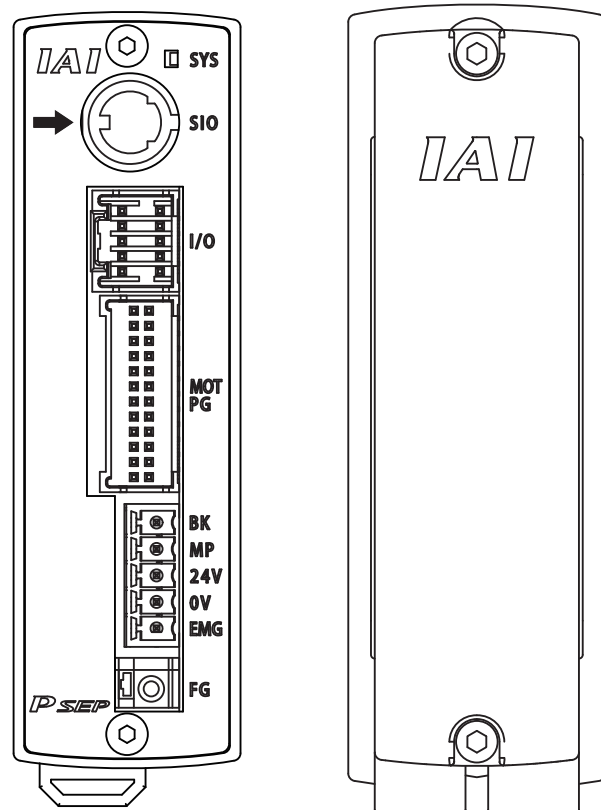

IAI America, Inc.



Please Read Before Use

Thank you for purchasing our product.

This Instruction Manual describes all necessary information items to operate this product safely such as the operation procedure, structure and maintenance procedure.

Before the operation, read this manual carefully and fully understand it to operate this product safely. The enclosed CD/DVD in this product package includes the Instruction Manual for this product.

For the operation of this product, print out the necessary sections in the Instruction Manual or display them using the personal computer.

After reading through this manual, keep this Instruction Manual at hand so that the operator of this product can read it whenever necessary.

[Important]

- This Instruction Manual is original.
- The product cannot be operated in any way unless expressly specified in this Instruction Manual. IAI shall assume no responsibility for the outcome of any operation not specified herein.
- Information contained in this Instruction Manual is subject to change without notice for the purpose of product improvement.
- If you have any question or comment regarding the content of this manual, please contact the IAI sales office near you.
- Using or copying all or part of this Instruction Manual without permission is prohibited.
- The company names, names of products and trademarks of each company shown in the sentences are registered trademarks.

A SEP/P SEP/D SEP====

Table of Contents

Safety Guide.....	1
International Standards Compliances	7
CE Marking.....	8
UL	8
Precautions in Operation	9
Name for Each Parts and Their Functions.....	13
Actuator Axes	15
Starting Procedures	17
1. Specifications Check	19
1.1 Product Check.....	19
1.1.1 Parts	19
1.1.2 Teaching Tool (to be purchased separately)	19
1.1.3 Instruction manuals related to this product, which are contained in the instruction manual (CD/DVD).	20
1.1.4 How to read the model plate	20
1.1.5 How to read the model of the controller.....	20
1.2 Basic Specifications	22
1.3 External Dimensions.....	24
1.4 I/O Specifications	25
1.4.1 PIO Input and Output Interface	25
1.5 Installation Environment.....	26
1.6 Installation and Noise Elimination	27
2. Wiring	29
2.1 Wiring Diagram (Connection of construction devices).....	29
2.2 PIO Pattern Selection and PIO Signal	30
2.3 Circuit Diagram (Example)	35
2.4 Wiring Method	41
2.4.1 Wiring Layout of Power Supply Connector	41
2.4.2 Wiring Layout of FG Terminal Block	42
2.4.3 Connection to Actuator	43
2.4.4 Connection of PIO	44
2.4.5 SIO Connector Connection.....	45
2.4.6 Battery Connector Connection (For Simple Absolute Type)	46

A*SEP/P***SEP/***D***SEP**

3.	Operation.....	48
3.1	Setting.....	48
3.1.1	Initial Setting	48
3.1.2	Position Data Setting	50
3.1.3	Absolute Reset (This function is effective only when the controller and actuator are the absolute type). ...	54
3.2	Power-up and PIO Control	55
3.2.1	Control of Input Signal	55
3.2.2	Power Input	56
3.2.3	Home-return	57
3.3	Timing Chart.....	58
3.4	User Parameters.....	63
3.5	Servo Adjustment.....	65
3.5.1	Adjustment for ASEP and PSEP	65
3.5.2	Adjustment for DSEP	66
3.5.3	Servo Parameter	68
3.6	Alarm.....	69
3.6.1	Alarm Level	69
3.6.2	Alarm Codes and Trouble Shooting	70
4.	Appendix	75
4.1	List of Specifications of Connectable Actuators.....	75
4.2	Pressing Force and Current Limit Value	99
5.	Warranty	106
5.1	Warranty Period	106
5.2	Scope of Warranty	106
5.3	Honoring Warranty.....	106
5.4	Limited Liability.....	106
5.5	Conditions of Conformance with Applicable Standards/Regulations, Etc., and Applications.....	107
5.6	Other Items Excluded from Warranty.....	107
	Change History.....	108

Safety Guide

“Safety Guide” has been written to use the machine safely and so prevent personal injury or property damage beforehand. Make sure to read it before the operation of this product.

Safety Precautions for Our Products

The common safety precautions for the use of any of our robots in each operation.

No.	Operation Description	Description
1	Model Selection	<ul style="list-style-type: none"> ● This product has not been planned and designed for the application where high level of safety is required, so the guarantee of the protection of human life is impossible. Accordingly, do not use it in any of the following applications. <ol style="list-style-type: none"> 1) Medical equipment used to maintain, control or otherwise affect human life or physical health. 2) Mechanisms and machinery designed for the purpose of moving or transporting people (For vehicle, railway facility or air navigation facility) 3) Important safety parts of machinery (Safety device, etc.) ● Do not use it in any of the following environments. <ol style="list-style-type: none"> 1) Location where there is any inflammable gas, inflammable object or explosive 2) Place with potential exposure to radiation 3) Location with the ambient temperature or relative humidity exceeding the specification range 4) Location where radiant heat is added from direct sunlight or other large heat source 5) Location where condensation occurs due to abrupt temperature changes 6) Location where there is any corrosive gas (sulfuric acid or hydrochloric acid) 7) Location exposed to significant amount of dust, salt or iron powder 8) Location subject to direct vibration or impact ● Do not use the product outside the specifications. Failure to do so may considerably shorten
2	Transportation	<ul style="list-style-type: none"> ● Consider well so that it is not bumped against anything or dropped during the transportation. ● Transport it using an appropriate transportation measure. ● Do not step or sit on the package. ● Do not put any heavy thing that can deform the package, on it. ● When using a crane capable of 1t or more of weight, have an operator who has qualifications for crane operation and sling work. ● When using a crane or equivalent equipments, make sure not to hang a load that weighs more than the equipment’s capability limit. ● Use a hook that is suitable for the load. Consider the safety factor of the hook in such factors as shear strength. ● Do not get on the load that is hung on a crane. ● Do not leave a load hung up with a crane. ● Do not stand under the load that is hung up with a crane.

A SEP/P SEP/D SEP

No.	Operation Description	Description
3	Storage and Preservation	<ul style="list-style-type: none"> ● The storage and preservation environment conforms to the installation environment. ● However, especially give consideration to the prevention of condensation.
4	Installation and Start	<p>(1) Installation of Robot Main Body and Controller, etc.</p> <ul style="list-style-type: none"> ● Make sure to securely hold and fix the product (including the work part). A fall, drop or abnormal motion of the product may cause a damage or injury. ● Do not get on or put anything on the product. Failure to do so may cause an accidental fall, injury or damage to the product due to a drop of anything, malfunction of the product, performance degradation, or shortening of its life. ● When using the product in any of the places specified below, provide a sufficient shield. <ol style="list-style-type: none"> 1) Location where electric noise is generated 2) Location where high electrical or magnetic field is present 3) Location with the mains or power lines passing nearby 4) Location where the product may come in contact with water, oil or chemical droplets <p>(2) Cable Wiring</p> <ul style="list-style-type: none"> ● Use our company's genuine cables for connecting between the actuator and controller, and for the teaching tool. ● Do not scratch on the cable. Do not bend it forcibly. Do not pull it. Do not coil it around. Do not insert it. Do not put any heavy thing on it. Failure to do so may cause a fire, electric shock or malfunction due to leakage or continuity error. ● Perform the wiring for the product, after turning OFF the power to the unit, so that there is no wiring error. ● When the direct current power (+24V) is connected, take the great care of the directions of positive and negative poles. If the connection direction is not correct, it might cause a fire, product breakdown or malfunction. ● Connect the cable connector securely so that there is no disconnection or looseness. Failure to do so may cause a fire, electric shock or malfunction of the product. ● Never cut and/or reconnect the cables supplied with the product for the purpose of extending or shortening the cable length. Failure to do so may cause the product to malfunction or cause fire <p>(3) Grounding</p> <ul style="list-style-type: none"> ● Make sure to perform the grounding of type D (Former Type 3) for the controller. The grounding operation should be performed to prevent an electric shock or electrostatic charge, enhance the noise-resistance ability and control the unnecessary electromagnetic radiation.

A SEP/P SEP/D SEP

No.	Operation Description	Description
4	Installation and Start	<p>(4) Safety Measures</p> <ul style="list-style-type: none"> ● When the product is under operation or in the ready mode, take the safety measures (such as the installation of safety and protection fence) so that nobody can enter the area within the robot's movable range. When the robot under operation is touched, it may result in death or serious injury. ● Make sure to install the emergency stop circuit so that the unit can be stopped immediately in an emergency during the unit operation. ● Take the safety measure not to start up the unit only with the power turning ON. Failure to do so may start up the machine suddenly and cause an injury or damage to the product. ● Take the safety measure not to start up the machine only with the emergency stop cancellation or recovery after the power failure. Failure to do so may result in an electric shock or injury due to unexpected power input. ● When the installation or adjustment operation is to be performed, give clear warnings such as "Under Operation; Do not turn ON the power!" etc. Sudden power input may cause an electric shock or injury. ● Take the measure so that the work part is not dropped in power failure or emergency stop. ● Wear protection gloves, goggle or safety shoes, as necessary, to secure safety. ● Do not insert a finger or object in the openings in the product. Failure to do so may cause an injury, electric shock, damage to the product or fire. ● When releasing the brake on a vertically oriented actuator, exercise precaution not to pinch your hand or damage the work parts with the actuator dropped by gravity.
5	Teaching	<ul style="list-style-type: none"> ● Perform the teaching operation from outside the safety protection fence, if possible. In the case that the operation is to be performed unavoidably inside the safety protection fence, prepare the "Stipulations for the Operation" and make sure that all the workers acknowledge and understand them well. ● When the operation is to be performed inside the safety protection fence, the worker should have an emergency stop switch at hand with him so that the unit can be stopped any time in an emergency. ● When the operation is to be performed inside the safety protection fence, in addition to the workers, arrange a watchman so that the machine can be stopped any time in an emergency. Also, keep watch on the operation so that any third person can not operate the switches carelessly. ● Place a sign "Under Operation" at the position easy to see. ● When releasing the brake on a vertically oriented actuator, exercise precaution not to pinch your hand or damage the work parts with the actuator dropped by gravity. <p>* Safety protection Fence : In the case that there is no safety protection fence, the movable range should be indicated.</p>

A SEP/P SEP/D SEP





No.	Operation Description	Description
6	Trial Operation	<ul style="list-style-type: none"> ● After the teaching or programming operation, perform the check operation one step by one step and then shift to the automatic operation. ● When the check operation is to be performed inside the safety protection fence, perform the check operation using the previously specified work procedure like the teaching operation. ● Make sure to perform the programmed operation check at the safety speed. Failure to do so may result in an accident due to unexpected motion caused by a program error, etc. ● Do not touch the terminal block or any of the various setting switches in the power ON mode. Failure to do so may result in an electric shock or malfunction.
7	Automatic Operation	<ul style="list-style-type: none"> ● Before the automatic operation is started up, make sure that there is nobody inside the safety protection fence. ● Before the automatic operation is started up, make sure that all the related peripheral machines are ready for the automatic operation and there is no error indication. ● Make sure to perform the startup operation for the automatic operation, out of the safety protection fence. ● In the case that there is any abnormal heating, smoke, offensive smell, or abnormal noise in the product, immediately stop the machine and turn OFF the power switch. Failure to do so may result in a fire or damage to the product. ● When a power failure occurs, turn OFF the power switch. Failure to do so may cause an injury or damage to the product, due to a sudden motion of the product in the recovery operation from the power failure.
8	Maintenance and Inspection	<ul style="list-style-type: none"> ● Perform the work out of the safety protection fence, if possible. In the case that the operation is to be performed unavoidably inside the safety protection fence, prepare the “Stipulations for the Operation” and make sure that all the workers acknowledge and understand them well. ● When the work is to be performed inside the safety protection fence, basically turn OFF the power switch. ● When the operation is to be performed inside the safety protection fence, the worker should have an emergency stop switch at hand with him so that the unit can be stopped any time in an emergency. ● When the operation is to be performed inside the safety protection fence, in addition to the workers, arrange a watchman so that the machine can be stopped any time in an emergency. Also, keep watch on the operation so that any third person can not operate the switches carelessly. ● Place a sign “Under Operation” at the position easy to see. ● For the grease for the guide or ball screw, use appropriate grease according to the Instruction Manual for each model. ● Do not perform the dielectric strength test. Failure to do so may result in a damage to the product. ● When releasing the brake on a vertically oriented actuator, exercise precaution not to pinch your hand or damage the work parts with the actuator dropped by gravity. <p style="text-align: center;">* Safety protection Fence : In the case that there is no safety protection fence, the movable range should be indicated.</p>

A SEP/P SEP/D SEP

No.	Operation Description	Description
9	Modification	<ul style="list-style-type: none">• Do not modify, disassemble, assemble or use of maintenance parts not specified based at your own discretion.• In such case, the warranty is not applied.
10	Disposal	<ul style="list-style-type: none">• When the product becomes no longer usable or necessary, dispose of it properly as an industrial waste.• Do not put the product in a fire when disposing of it. The product may burst or generate toxic gases.

Alert Indication

The safety precautions are divided into “Danger”, “Warning”, “Caution” and “Notice” according to the warning level, as follows, and described in the Instruction Manual for each model.

Level	Degree of Danger and Damage	Symbol
Danger	This indicates an imminently hazardous situation which, if the product is not handled correctly, will result in death or serious injury.	 Danger
Warning	This indicates a potentially hazardous situation which, if the product is not handled correctly, could result in death or serious injury.	 Warning
Caution	This indicates a potentially hazardous situation which, if the product is not handled correctly, may result in minor injury or property damage.	 Caution
Notice	This indicates lower possibility for the injury, but should be kept to use this product properly.	 Notice

A SEP/P SEP/D SEP

International Standards Compliances

ASEP/PSEP and DSEP comply with the following international standards:

RoHS Directive	CE Marking	UL ^(Note)
○	○	○

(Note) The DSEP is not applicable to UL.

CE Marking

If a compliance with the CE Marking is required, please follow Overseas Standards Compliance Manual (ME0287) that is provided separately.

UL

To comply with UL, please be aware and take an action for the following items;

- 1) The product is applicable for a use in an environment of Pollution Degree 2 or equivalent.
- 2) ASEP and PSEP are equipped with a function for overcurrent protection performed by a semiconductor.
For ASEP, the protection is triggered with the current greater in 1.4 times than the maximum load current.
- 3) Make sure to use the product within the range of the applicable ambient temperature.
[Refer to 1.2 Basic Specifications]
- 4) Mount a glass tube fuse that possesses the characteristics of the class k5, 600Vdc and 5A to the power line between the 24V power supply and ASEP or PSEP.
- 5) The motor used in the actuator that is connected to ASEP would not exceed 5,000 rotations even if 24V power voltage and maximum current are applied.
- 6) To protect a junction circuit, follow the methods specified in NEC or an equivalent regulation.

Precautions in Operation

1. Use the following teaching tools.

Use the teaching tool such as the PC software stated in the next clause as the applicable for this controller.

- Teaching Tools that is applicable for this controller

[Refer to 1.2.2]

2. Backup the data to secure for breakdown.

A non-volatile memory is used as the backup memory for this controller. All the registered position data and parameters are written into this memory and backed-up at the same time. Therefore, you will not usually lose the data even if the power is shut down. However, make sure to save the latest data so a quick recovery action can be taken in case when the controller is broken and needs to be replaced with another one.

How to Save Data

- (1) Save the data to CD-R or hard disk with using the PC software
- (2) Hard-copy the information of position tables and parameters on paper

3. Set the operation patterns.

This controller possesses 6 types of control logics to meet various ways of usage, and changes the role of each PIO signal following the selected control logic.

The setup can be performed in the initial setting.

[Refer to 2.1]

The PIO pattern is set to "0" (Standard Point-to-Point Movement) when the unit is delivered. Set the operation pattern setting to the logic that suits to your use after the power is turned on.

Warning:

Please note it is very risky when the control sequence and PIO pattern setting do not match to each other. It may not only cause the normal operation disabled, but also may cause an unexpected movement.

4. Operation cannot be performed unless there is an input of Servo-on Signal and Pause Signal.

(1) Servo-on Signal (SON)

Servo-on signal (SON) is selectable from either “Enable” or “Disable” by the setting.

It is settable in the initial setting.

[Refer to 2.1 Setting]

If it is set to “Enable”, the actuator would not operate unless turning this signal on.

If it is set to “Disable”, the servo becomes on and the actuator operation becomes enabled as soon as the power supply to the controller is turned on and the emergency stop signal is cancelled.

[Refer to 2.1 Setting]

It is set to “Disable” when the unit is delivered. Have the setting that suits to the desirable control logic.

(2) Pause Signal (*STP)

The input signal of the pause signal (*STP) is always on considering the safety. Therefore, in general, the actuator would not operate if this signal is not on.

It is available to make this signal to “Not to use”, if this signal is undesirable.

It is settable in the initial setting.

[Refer to 2.1 Setting]

If it is set to “Not to use”, the actuator operation is available even without this signal being on.

It is set to “Not to use” when the unit is delivered.

5. Rotary actuator cannot be set to Multi-Rotation Specification.

Rotary actuator cannot be set to Multi-Rotation Specification since the index mode setting cannot be performed.

6. Transference of PIO Signal between Controllers

Please note the following when conducting transference of PIO signal between controllers.

To certainly transfer the signal between controllers with different scan time, it is necessary to have longer scan time than the one longer than the other controller. To ensure to end the process safely, it is recommended to have the timer setting more than twice as long as the longer scan time at least.

● Operation Image

PLC

(e.g. scan time is 20msec)

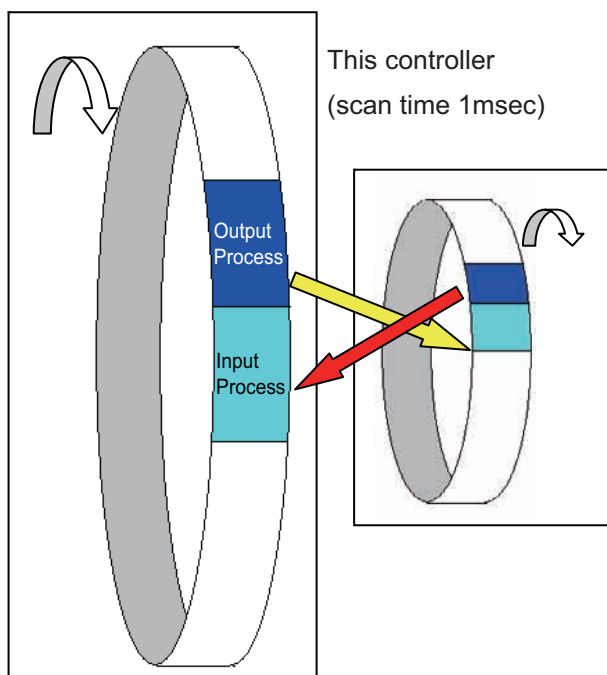

As shown in the diagram, the input and output timings of two devices that have different scan time do not match, of course, when transferring a signal.

There is no guarantee that PLC would read the signal as soon as this controller signal turns on. In such a case, make the setting to read the signal after a certain time that is longer than the longer scan time to ensure the reading process to succeed on the PLC side.

It is the same in the case this controller side reads the signal.

In such a case, it is recommended to ensure 2 to 4 times of the scan time for the timer setting margin.

It is risky to have the setting below the scan time since the timer is also processed in the scan process.

In the diagram, PLC can only read the input once in 20msec even though this controller output once in 1msec.

Because PLC only conducts output process once in 20msec, this controller identifies the same output status for that while.

Also, if one tries to read the signal that is being re-written by the other, the signal may be read wrongly. Make sure to read the signal after the rewriting is complete. (It is recommended to have more than 2 scan periods to wait.) Make sure not to have the output side to change the output until the other side completes the reading. Also, a setting is made on the input area not to receive the signal less than a certain time to prevent a wrong reading of noise. This duration also needs to be considered.

A SEP/P SEP/D SEP

7. PLC Timer Setting

Do not have the PLC timer setting to be done with the minimum setting.

Setting to "1" for 100msec timer turns on at the timing from 0 to 100msec while 10msec timer from 0 to 10msec for some PLC.

Therefore, the same process as when the timer is not set is held and may cause a failure such as the actuator cannot get positioned to the indicated position number in Positioner Mode.

Set "2" as the minimum value for the setting of 10msec timer and when setting to 100msec, use 10msec timer and set to "10".

8. Cautions when turning Servo on (for ASEP/PSEP)

The magnetic pole phase detection may not be performed normally if the servo is turned on near the mechanical end, and may cause such problems like an abnormal operation, magnetic pole not being defined or electromagnetic detection error.

Put it away from the mechanical end when turning the servo on.

9. Make sure to follow the usage condition, environment and specifications of the product.

Not doing so may cause a drop of performance or malfunction of the product.

A SEP/P SEP/D SEP

Name for Each Parts and Their Functions

Pictures show ASEP, It should be the same for PSEP and DSEP.

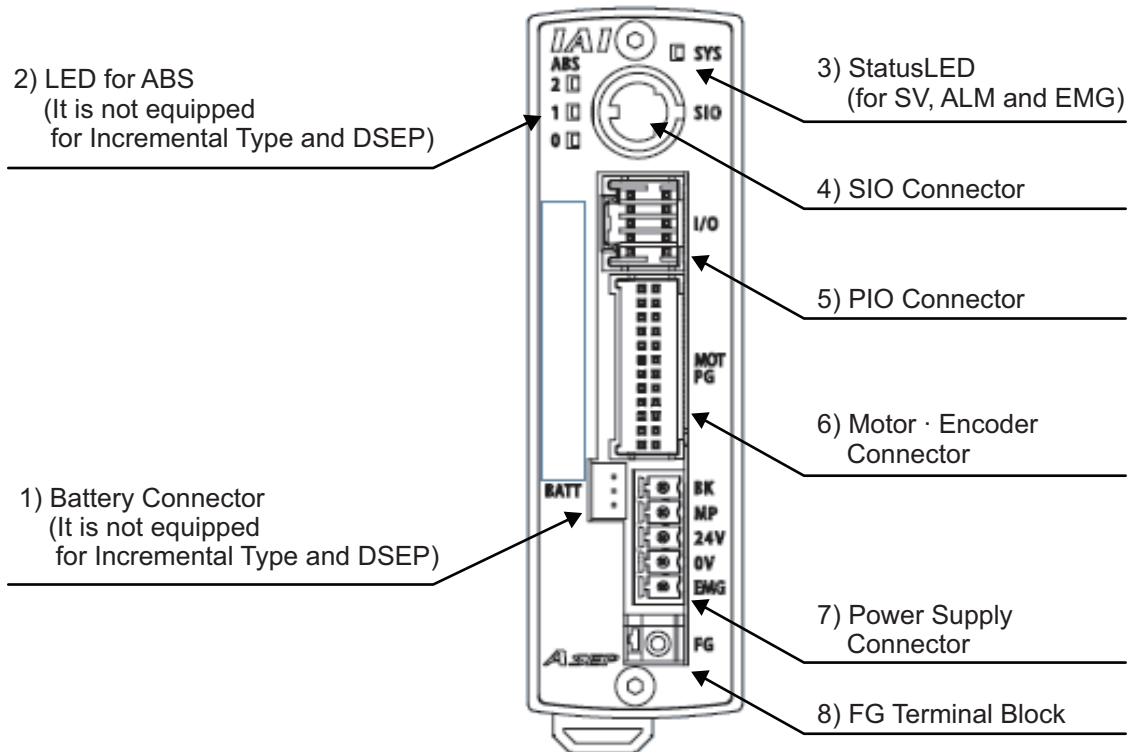

1) Battery Connector (It is not equipped for Incremental Type and DSEP)
If Absolute Type actuator, it is the battery connector for absolute data retention.

2) LED for ABS (It is not equipped for Incremental Type and DSEP)
Following shows the absolute data retention battery status:

Signal	Indication Status	Description
2	Green Light is turned ON.	System Normal
	Red Light is turned ON.	System abnormality
1	Green Light is turned ON	Absolute Unit Reset Complete (ST2 lighting ON in Green)
	Red Light is turned ON.	<ul style="list-style-type: none"> Absolute Unit Reset Incomplete (ST2 lighting ON in Green) Hardware Error (ST2 lighting ON in Red)
0	Green Light is turned ON	Battery Fully Charged
	Orange Light is turned ON.	In Battery Charging Operation
	Red Light is turned ON.	Battery Disconnected

ASEP/PSEP/DSEP

3) StatusLED (For SV, ALM and EMG)

Following show the controller operation status:

	Indication Status	Description
SYS	Green Light is turned ON.	Servo ON Status
	Light is turned OFF	Servo OFF Status
	Flashing in green (1Hz)	Servo ON Status
	Red Light is turned ON.	In the alarm issue or emergency stop

4) SIO Connector

It is the connector for the connection of the communication cables for the teaching pendant and PC software.

5) PIO Connector

It is the connector for 24V DC I/O signal connection.

6) Motor · Encoder Connector

It is the connector to connect the actuator motor · encoder cable.

7) Power Supply Connector

It is the connector to supply the power to the controller and to the control board.

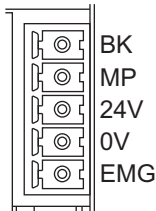

Pin No.	Signal	Description
5	BK	For Brake Forced Release Power Supply (ASEP/PSEP) Keep DSEP disconnected.
4	MP	Motor Driving Power Supply
3	24V	Positive side of the 24V power supply
2	0V	Negative side of the 24V power supply
1	EMG	EMG's Confirmation Signal

8) FG Terminal Block

It is the connector to connect the protection ground. Make sure to conduct the Class D grounding (formerly Class 3 grounding: grounding resistance at 100Ω or less)

Actuator Axes

Refer to the pictures below for the actuator axes that can be controlled by ASEP/PSEP and DSEP. (There are some types that cannot be controlled depending on the controller. Check the catalog for the details.)

0 defines the home position, and items in () are for the home-reversed type (option).

(1) Rod Type

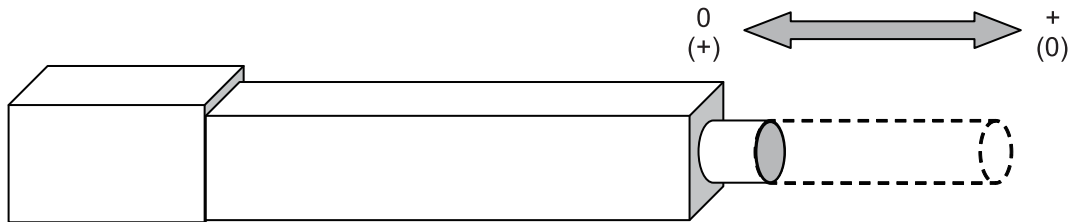

(2) Slider Type

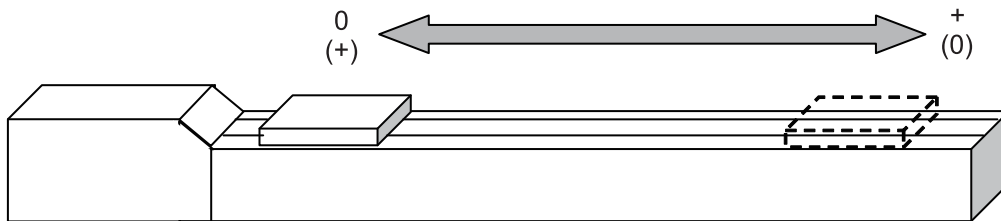

(3) Table Type

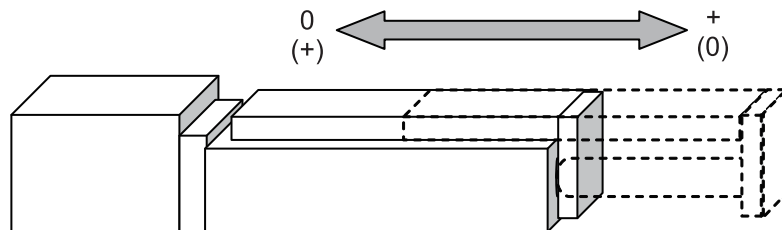

(4) Arm Type

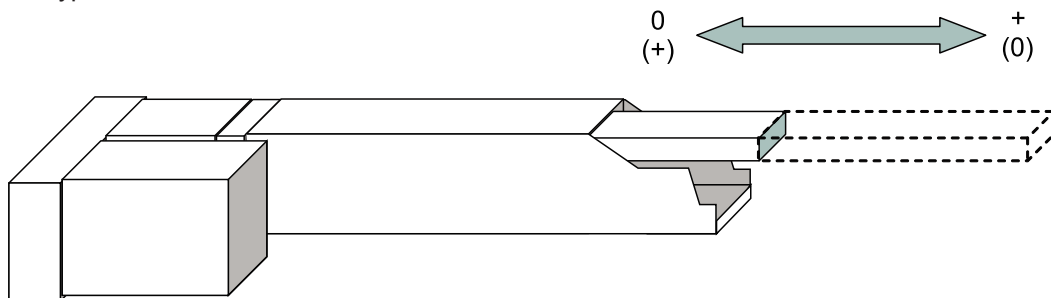

A SEP/P SEP/D SEP

(5) Gripper Type

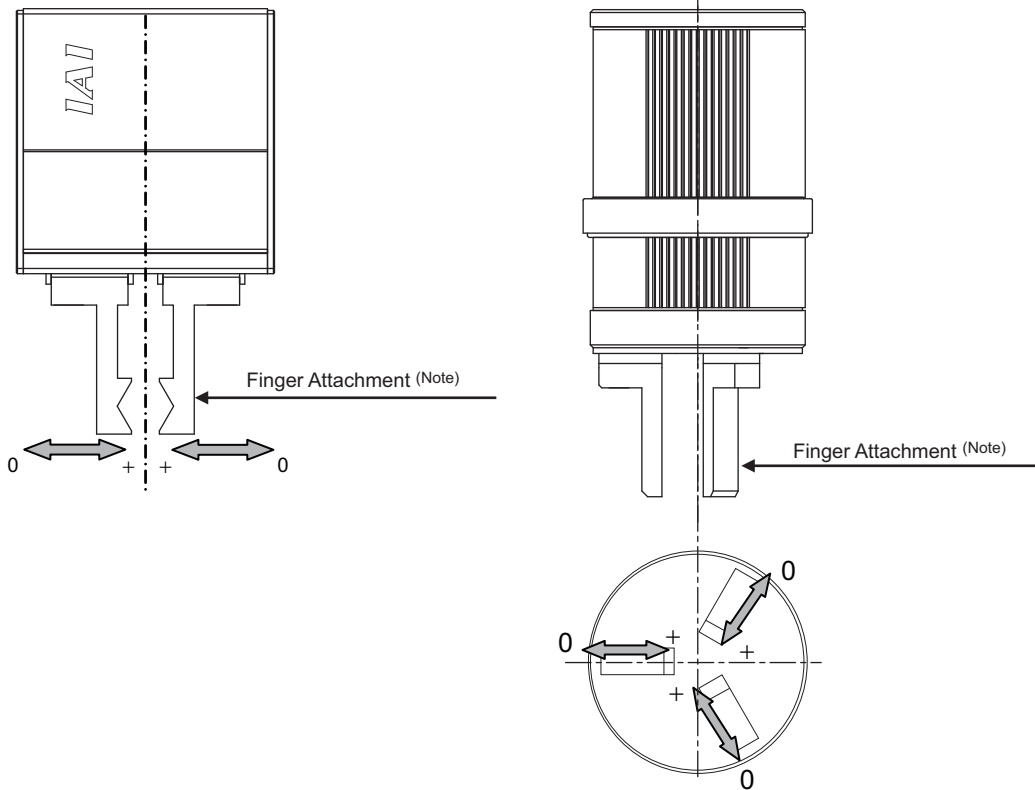

Note: Finger attachment is not included in the actuator package. Please prepare separately.

(6) Rotary Type

(330° Rotation Specification)

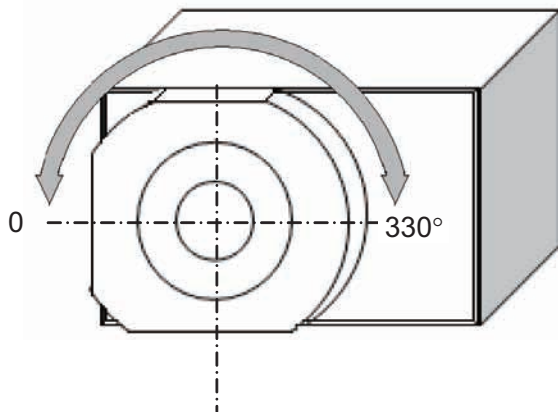

(Multi-Rotation Specification)

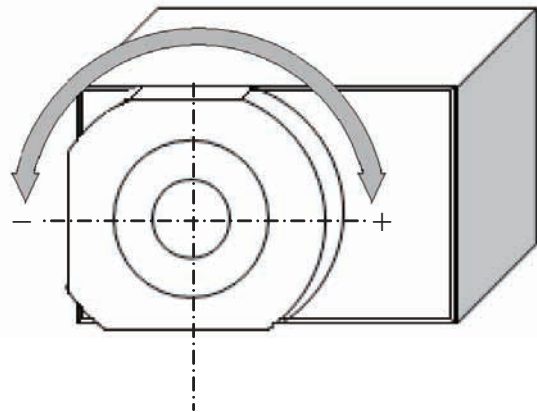

Starting Procedures

When using this product for the first time, make sure to avoid mistakes and incorrect wiring by referring to the procedure below.

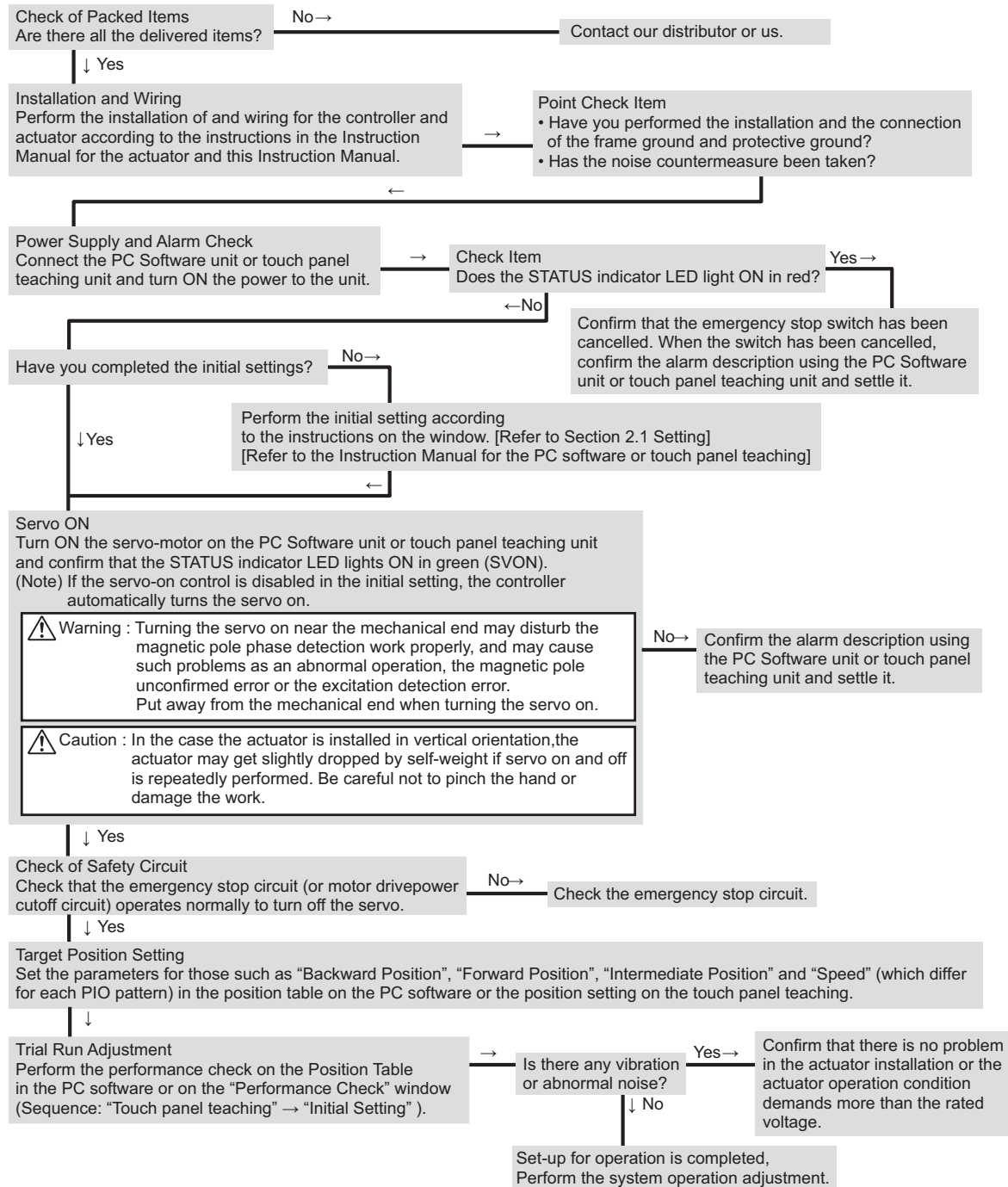

A SEP/P SEP/D SEP====

1. Specifications Check

1.1 Product Check

This product is comprised of the following parts if it is of standard configuration.

If you find any fault in the contained model or any missing parts, contacts us or our distributor.

1.1.1 Parts

No.	Part Name		Model
1	Controller		[Refer to "1.2.4 How to read the model plate"]
Accessories			
2	I/O Flat cable	Standard type	CB-APSEP-PIO*** (**shows the cable length)
		Dust-proof type (Equivalent to IP53)	CB-APSEPW-PIO*** (**shows the cable length)
3	Power Connector		MC1.5/5-ST-3.5 (PHOENIX CONTACT)
4	Spacer		PFP-S (OMRON)
5	Absolute Battery Unit (For Simple Absolute Type Only)		SEP-ABUM (Standard type)
			SEP-ABUM-W (Dust-proof type)
6	Instruction Manual (This Manual)		
7	Instruction Manual (CD/DVD)		
8	Safety Guide		

1.1.2 Teaching Tool (to be purchased separately)

For the setups such as position setting and parameter setting using the teaching operation, the teaching tool is required. Please prepare either of the following teaching tools.

No.	Part Name	Model
1	PC Software (Includes RS232C Exchange Adapter + External Machine Communication Cable)	RCM-101-MW
2	PC Software (Includes USB Exchange Adapter + USB Cable + External Machine Communication Cable)	RCM-101-USB
3	Teaching Pendant (Touch Panel Teaching)	CON-PTA
4	Teaching Pendant (Touch panel teaching equipped with a dead man's switch)	CON-PDA
5	Teaching Pendant (Touch panel teaching equipped with a dead man's switch + TP adapter (RCB-LB-TG))	CON-PGA
6	Teaching Pendant dedicated for SEP Controller (Touch Panel Teaching)	SEP-PT
7	Teaching Pendant (Touch Panel Teaching)	CON-PT ^(Note 1)
8	Teaching Pendant (Touch panel teaching equipped with a dead man's switch)	CON-PD ^(Note 1)
9	Teaching Pendant (Touch panel teaching equipped with a dead man's switch + TP adapter (RCB-LB-TG))	CON-PG ^(Note 1)

Note 1) It is not applied for DSEP.

ASEP/PSEP/DSEP

1.1.3 Instruction manuals related to this product, which are contained in the instruction manual (CD/DVD).

No	Name	Manual No.
1	ASEP/PSEP/DSEP Instruction Manual	ME0267
2	PC Software RCM-101-MW/RCM-101-USB Instruction Manual	ME0155
3	Touch Panel Teaching CON-PTA/PDA/PGA Instruction Manual	ME0294
4	Teaching Pendant dedicated for SEP Controller (Touch Panel Teaching) Instruction Manual	ME0217

1.1.4 How to read the model plate

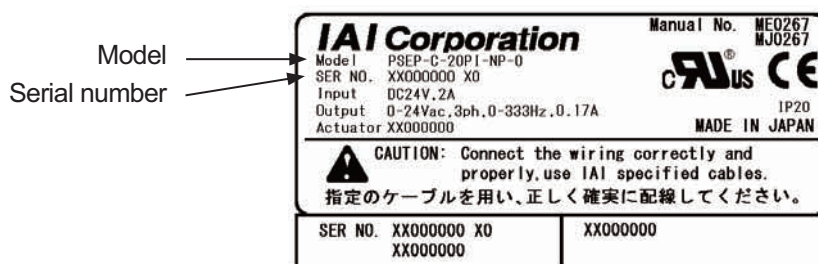

1.1.5 How to read the model of the controller

[ASEP]

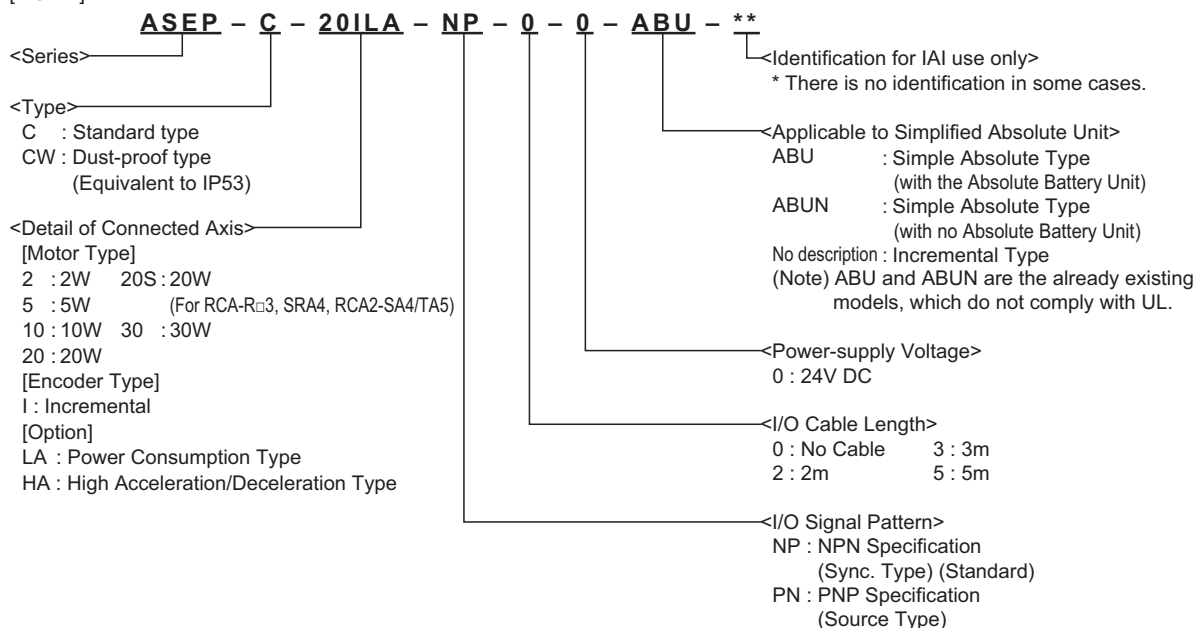

A SEP / P SEP / D SEP

[PSEP]

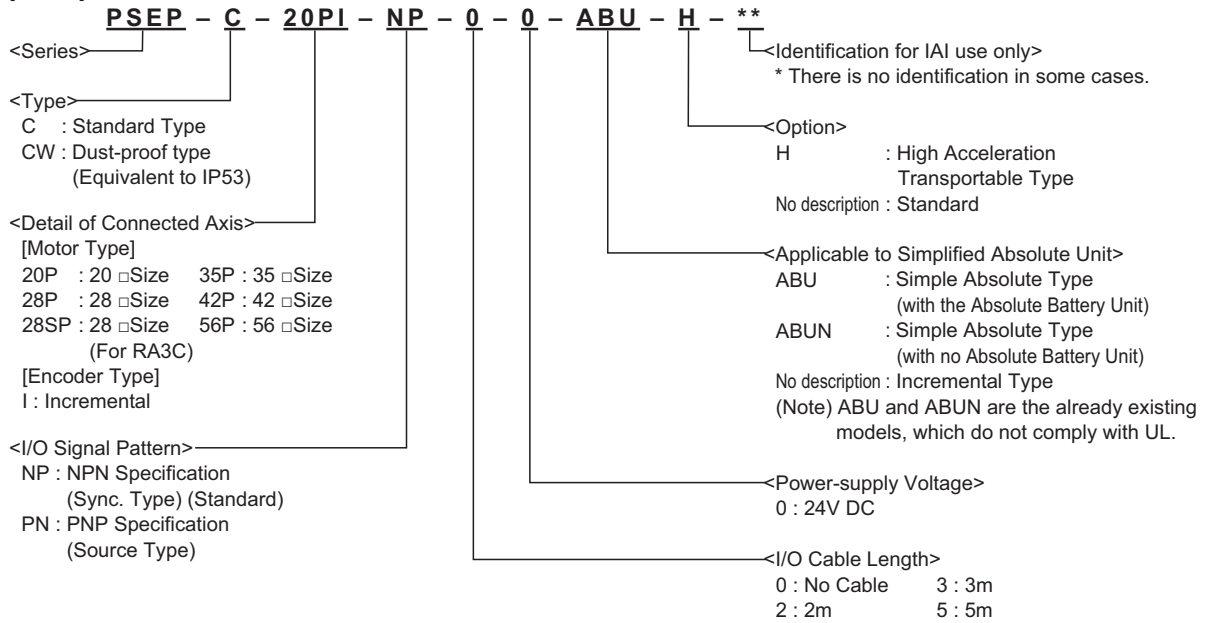

[DSEP]

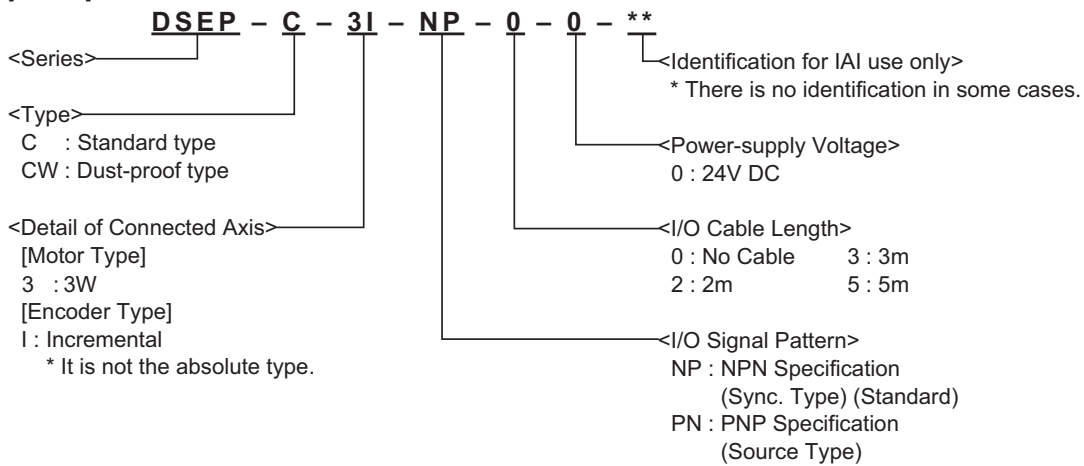

ASEP/PSEP/DSEP

1.2 Basic Specifications

Specifications

Item		ASEP			PSEP		DSEP	
Number of controlled axes		1-axis						
Power-supply voltage		24V DC \pm 10%						
Control power capacity		0.5A (For Simple Absolute Type, 1.8A)						
Load current	Motor type	Rated	Low Power Consumption	MAX. (Note 1)	Rated	MAX. (Note 2)	Rated	MAX.
	2W	0.8A	/	4.6A	/	/	/	/
	5W	1.0A	/	6.4A	/	/	/	/
	10W (RCL series)	1.3A	/	6.4A	/	/	/	/
	10W (RCA/RCA2 series)	1.3A	2.5A	4.4A	/	/	/	/
	20W	1.3A	2.5A	4.4A	/	/	/	/
	20W (Model code display 20S)	1.7A	3.4A	5.1A	/	/	/	/
	30W	1.3A	2.2A	4.4A	/	/	/	/
	20P	/	/	/	0.17A	2.0A	/	/
	28P	/	/	/	0.17A	2.0A	/	/
	35P	/	/	/	0.9A	2.0A	/	/
	42P	/	/	/	0.9A	2.0A	/	/
	56P	/	/	/	0.9A	2.0A	/	/
	3W	/	/	/	/	/	0.7A	1.5A
Heat generation		8.4W			9.6W		4W	
Rush current		MAX. 10A						
Motor control system		Sinusoidal wave (AC) driving			Weak field-magnet vector control		Square wave (DC) drive	
Applicable encoder resolution	RCA series		800pulse/rev					
	RCA2 series	RCA2-***N	1048pulse/rev					
		Except for RCA2-***N	800pulse/rev					
	RCL series	RA1L, SA1L, SA4L, SM4L	715pulse/rev					
		RA2L, SA2L, SA5L, SM5L	855pulse/rev					
		RA3L, SA3L, SA6L, SM6L	1145pulse/rev					
	RCP2, RCP3, RCP4		/			800pulse/rev		/
RCD		/			/		400pulse/rev	
Actuator cable length		MAX. 20m						
Serial communication interface (SIO port)		RS485 : 1CH (based on Modbus Protocol RTU/ASCII)						
External interface		Signal I/O dedicated for 24V DC (selected from NPN/PNP) ... Input 4 points max., output 4 points max. Cable length MAX. 10m						
Data setting and input		PC softwar, touch panel teaching, teaching pendant						
Data retention memory		Position data and parameters are saved in the nonvolatile memory. (About 100,000 times of reloading ^(Note 3))						
Operation mode/No. of positions		Positioner mode Positioning points : 2 to 3 points						
LED display (mounted on front panel)		1 point (for controller status display)						

A SEP/P SEP/D SEP

Item	ASEP	PSEP	DSEP
Forcibly releasing of electromagnetic brake switch	None Supply 24V DC 150mA to BK on power connector when a compulsory release of the brake is required.		None Brake cannot be compulsorily released.
Dielectric withstanding voltage/resistance	500V DC 10MΩ		
Protection Function against Electric Shock	Class I basic insulation		
Cooling method	Natural air-cooling		
Environment	Ambient air temperature	0 to 40°C	
	Ambient humidity	85% RH or less (non-condensing)	
	Ambient environment	[Refer to 1.5 Installation Environment.]	
	Ambient storage temperature	-25 to 65°C (Battery to be stored at 40°C or lower)	
	Usage altitude	1000m or lower above sea level	
	Protection code	IP20: Equivalent to IP53 (Option) with the installation of the dust-proof cover	
	Vibration durability	Frequency 10 to 57Hz / Swing width : 0.075mm Frequency 57 to 150Hz / Acceleration : 9.8m/ S ² XYZ Each direction Sweep time : 10 minutes Number of sweep : 10 times	
	Weight	130g or less, 160g or less (INC-Dust-proof type)	
	External dimensions	30W × 100H × 66.2D (mm)	

(Note 1) The current reaches its maximum level when the servo-motor exciting phase is detected which is to be performed in the first servo-motor turning ON processing after the power injection.
(Normal: Approx. 1 to 2sec, Max.: 10sec)

(Note 2) The excitation detection operation is performed after the power is input. In such a case, the current becomes maximum.
(normally 100msec)
However, a current of approx. 6.0A flows if the motor driving power is turned on again after its shutdown. (for approx. 1 to 2msec)



As a + 24V DC power supply, select the power supply of the "peak load support" specification or one with sufficient capacity.
In the case that the capacity margin is not sufficient, voltage might be dropped in a moment. Especially, the power supply equipped with remote sensing reacts to the transient voltage drop and raises the voltage for adjustment, which may result in overvoltage error.

Note 3: Position data and parameters are written to EEPROM. The limitation for the reload is about 100,000 times. Take the greatest care.
Do not turn the power off during the rewriting process.

ASEP/PSEP/DSEP

1.3 External Dimensions

[ASEP/PSEP/DSEP-C]

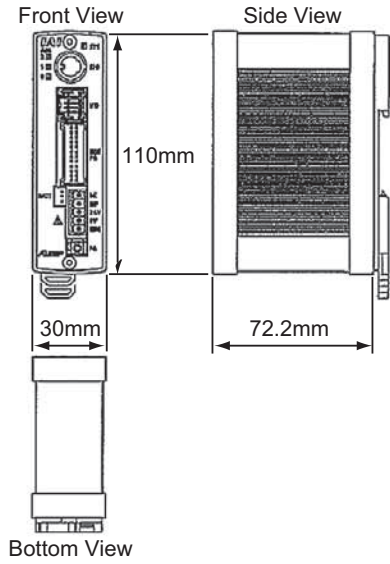

[Dust-Proof Cover : ASEP/PSEP/DSEP-CW]

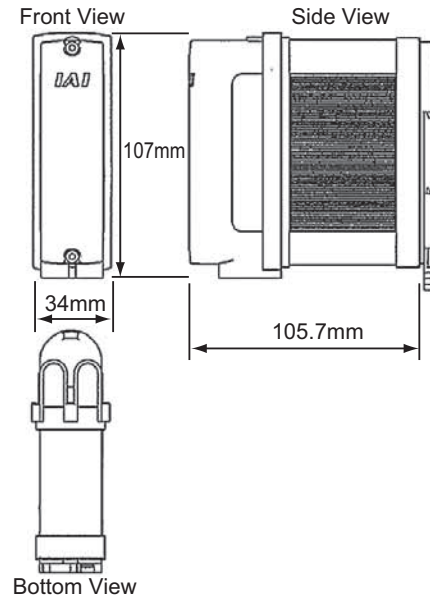

[Absolute Battery Unit SEP-ABUM (only applies to ASEP/PSEP)]

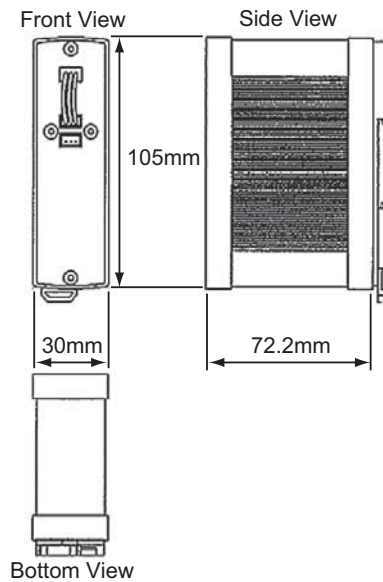

A SEP/P SEP/D SEP

1.4 I/O Specifications

1.4.1 PIO Input and Output Interface

	Input Section		Output Section	
Specification	Input Voltage	24V DC±10%	Load Voltage	24V DC
	Input Current	4mA 1circuit	Peak Load Electric Current	50mA/1circuit
	ON/OFF Voltage	ON Voltage MIN.18V DC OFF Voltage MAX.6V DC	Leakage Current	MAX.0.1mA/1point
NPN				
PNP				
I/O Cable	Refer to 2.1.3 Circuit Diagram			

NPN Type

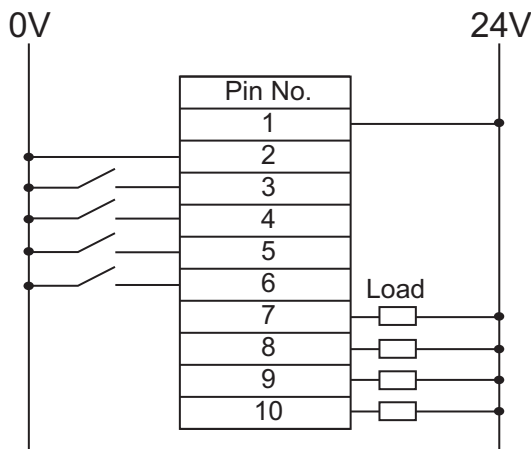

PNP Type

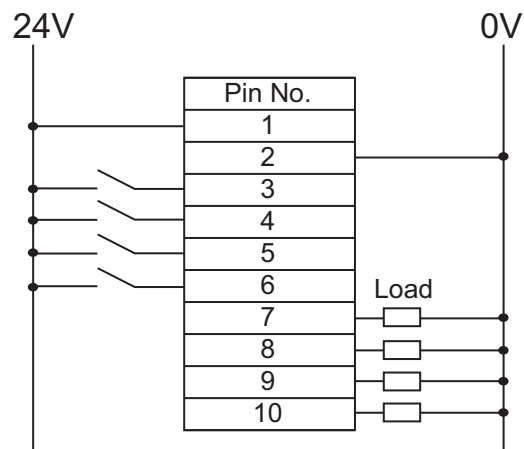

1.5 Installation Environment

This product is capable for use in the environment of pollution degree 2¹ or equivalent.

*1 Pollution Degree 2: Environment that may cause non-conductive pollution or transient conductive pollution by frost (IEC60664-1)

Do not use this product in the following environment.

- Location where the surrounding air temperature exceeds the range of 0 to 40°C
- Location where condensation occurs due to abrupt temperature changes
- Relative humidity less than 10%RH or greater than 85%RH
- Location exposed to corrosive gases or combustible gases
- Location exposed to significant amount of dust, salt or iron powder
- Location subject to direct vibration or impact
- Location exposed to direct sunlight
- Location where the product may come in contact with water, oil or chemical droplets

When using the product in any of the locations specified below, provide a sufficient shield.

- Location subject to electrostatic noise
- Location where high electrical or magnetic field is present
- Location with the mains or power lines passing nearby

For Dust-proof type (Equivalent to IP53)

The protection structure level is enhanced to IP53 with the installation of the dust-proof cover (option).

"5" in IP53 stands for the structure	Where the amount of dust which can affect the normal operation and safety, can not enter the unit.
"3" in IP53 stands for the structure	Where normal operation and safety is not affected even with the precipitation from above.

1.6 Installation and Noise Elimination

(1) Noise Elimination Grounding (Frame Ground)

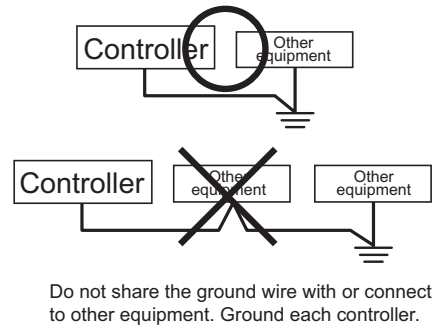
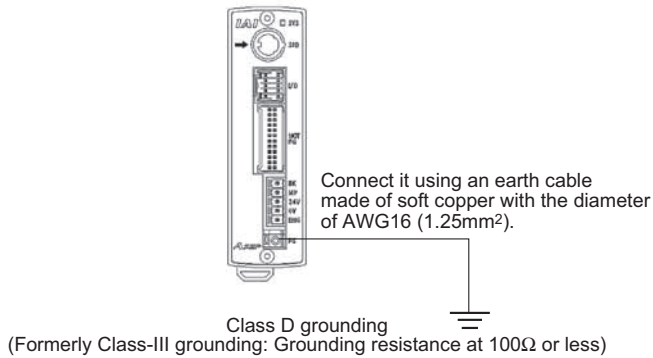

(2) Precautions regarding wiring method

- 1) Twist the wires for the 24V DC power unit.
- 2) Separate signal lines and encoder cables from high-power lines such as the power wire.

(3) Noise Sources and Elimination

Carry out noise elimination measures for power devices on the same power path and in the same equipment. The following are examples of measures to eliminate noise sources.

- 1) AC solenoid valves, magnet switches and relays
[Measure] Attach the surge killer in parallel with the coil.
- 2) DC solenoid valves, magnet switches and relays
[Measure] Attach the diode in parallel with the coil.

For the DC relay, use the built-in diode type.

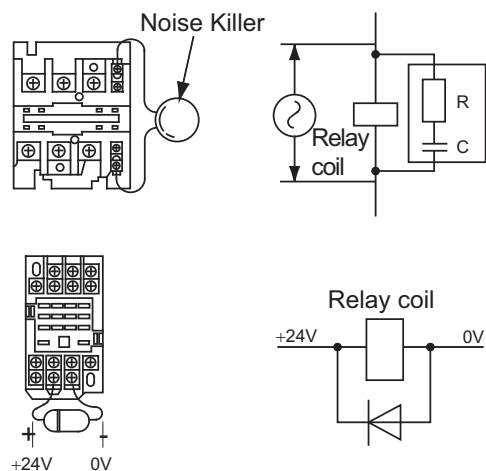

A SEP/P SEP/D SEP

(4) Heat Radiation and Installation

Conduct design and manufacture in consideration of the control box size, controller layout and cooling in such a way that the temperature around the controller will be 40°C or less.

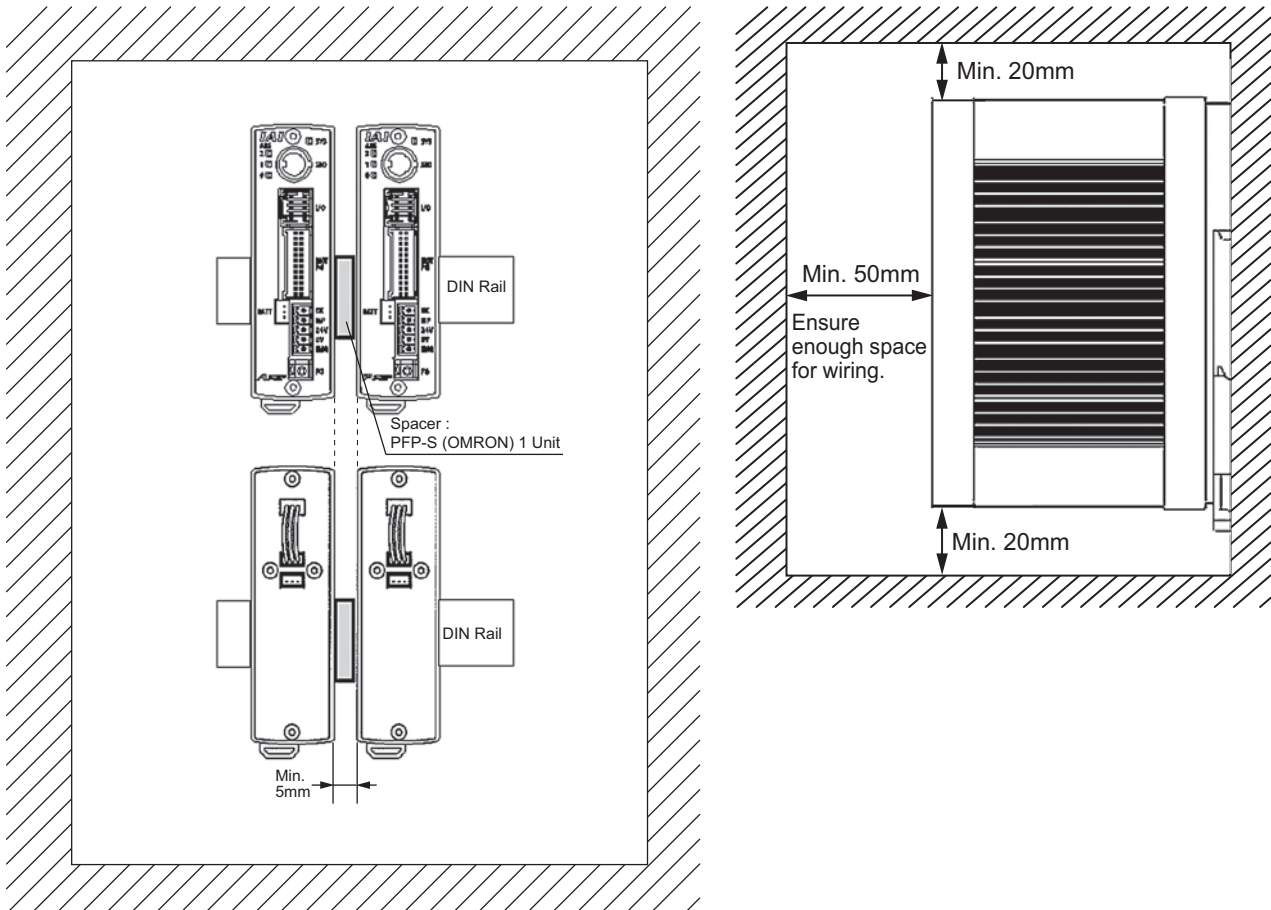

Note Install the Absolute Battery Unit securely under the controller.

A SEP/P SEP/D SEP

2. Wiring

2.1 Wiring Diagram (Connection of construction devices)

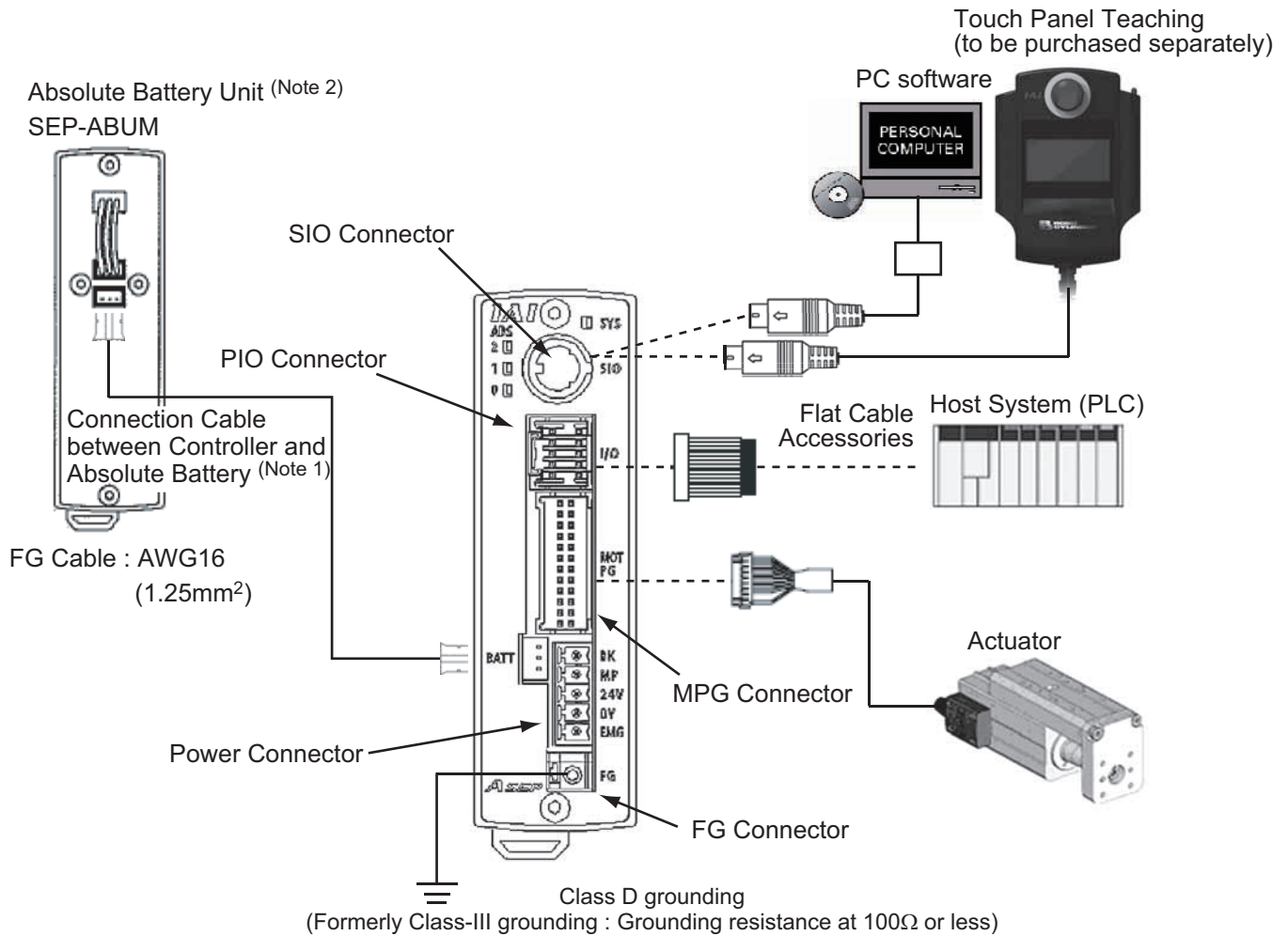

- (Note 1) Connection Cable between Controller and Absolute Battery
CB-APSEP-ABM005••• Applicable Controller : ASEP-C-□-□-□-0-ABUM□
PSEP-C-□-□-□-0-ABUM□
CB-APSEP-AB005••• Applicable Controller : ASEP-C-□-□-□-0-ABU□
(Existing models: Not complied with UL) PSEP-C-□-□-□-0-ABU□

(Note 2) It is not compatible with DSEP.

⚠ Note Turn the power to the controller off before connecting and disconnecting SIO connector plugged in the controller from the PC software or touch panel teaching. Inserting or removing the connector while the power is turned ON causes a controller failure.

2.2 PIO Pattern Selection and PIO Signal

(1) Operation Pattern

The 6 operation patterns (For PIO Pattern). Each of these 6 patterns is described as in the table. Also, the corresponding air cylinder circuit is described for reference.

Operation Pattern	Contents	Example for Electric Cylinder Connection	Example for Air Cylinder Connection (Reference)
PIO Pattern 0 Single Solenoid System (Standard Point-to-Point Movement)	The actuator point-to-point movement is available using the same control function as for the air cylinder. The target position setting (forward position and backward position) is available. Speed and acceleration settings in the actuator movement are available.		
PIO Pattern 0 Double Solenoid System (Standard Point-to-Point Movement)	The pressing operation is available.		
PIO Pattern 1 Single Solenoid System (Point-to-Point Movement) (Movement Speed Setting)	The actuator point-to-point movement is available using the same control function as for the air cylinder. The speed change in the movement operation is available. The target position setting (forward position and backward position) is available.		
PIO Pattern 1 Double Solenoid System (Point-to-Point Movement) (Movement Speed Setting)	Speed and acceleration settings in the actuator movement are available. The pressing operation is available.		

A SEP/P SEP/D SEP

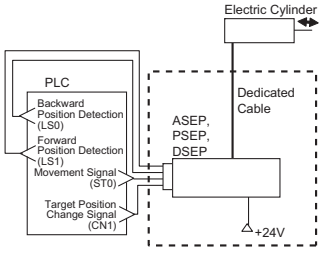
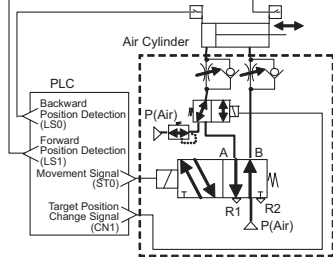
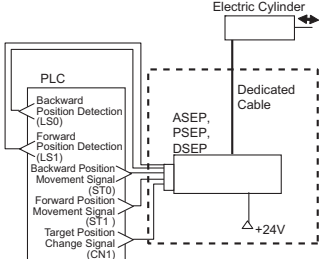
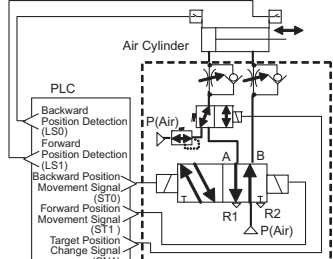
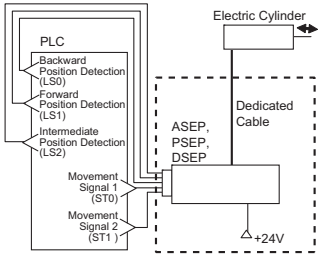
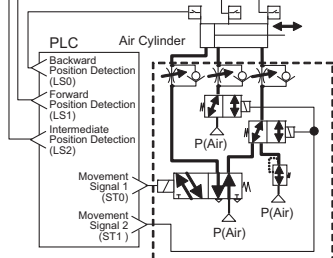
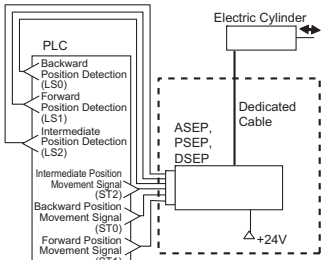
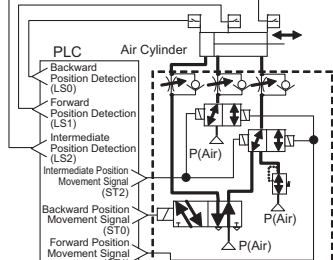
Operation Pattern	Contents	Example for Electric Cylinder Connection	Example for Air Cylinder Connection (Reference)
<p>Single Solenoid System (Point-to-Point Movement) (Target Position Setting (Position Data) Change)</p>	<p>The actuator point-to-point movement is available using the same control function as for the air cylinder. The change-over between the positioning and pressing operations during the operation is available. The target position setting (forward position and backward position) is available. Speed and acceleration settings in the actuator movement are available. The pressing operation is available.</p>		
<p>PIO Pattern 2 Double Solenoid System (Point-to-Point Movement) (Target Position Setting (Position Data) Change)</p>	<p>The actuator 3-Point Movement is available using the same control function as for the air cylinder. The target position setting (forward position, backward position and intermediate position) is available. Speed and acceleration settings in the actuator movement are available. The pressing operation at the positions except for the intermediate position is available.</p>		
<p>PIO Pattern 3 (2-Input, 3-Point Movement)</p>	<p>The actuator 3-Point Movement is available using the same control function as for the air cylinder. The target position setting (forward position, backward position and intermediate position) is available. Speed and acceleration settings in the actuator movement are available. The pressing operation at the positions except for the intermediate position is available.</p>		
<p>PIO Pattern 4 (3-Input, 3-Point Movement)</p>	<p>The actuator 3-Point Movement is available using the same control function as for the air cylinder. The target position setting (forward position, backward position and intermediate position) is available. Speed and acceleration settings in the actuator movement are available. The pressing operation at the positions except for the intermediate position is available.</p>		

ASEP/PSEP/DSEP

Operation Pattern	Contents	Example for Electric Cylinder Connection	Example for Air Cylinder Connection (Reference)
PIO Pattern 5 (Continuous Reciprocating Operation)	The actuator's point-to-point reciprocating operation is performed between the forward position and backward position. The target position setting (forward position and backward position) is available. Speed and acceleration settings in the actuator movement are available. The pressing operation is available.		

Note: The air cylinder circuit is described with the symbols for the signals corresponding to those in ASEP/PSEP/DSEP.
 [Refer to the next page for the details of each signal.]

(2) PIO Pattern and Signal Assignment

Pattern			0		1		2		3	4	5	
			Point-to-Point Movement (Standard)		Point-to-Point Movement (Movement Speed Setting)		Point-to-Point Movement (Target Position Setting Change)		3-Point Movement (2-Input)	3-Point Movement (3-Input)	Point-to-Point Reciprocating Movement (Continuous Reciprocating Operation)	
Pin No.	Cable Color	Input/Output	Single	Double	Single	Double	Single	Double	-	Double	-	
1	BR	COM	24V		24V		24V		24V	24V	24V	
2	RD	COM	0V		0V		0V		0V	0V	0V	
3	OR	I N	0	ST0	ST0	ST0	ST0	ST0	ST0	ST0	ASTR	
4	YW		1	*STP	ST1 ^(Note 1)	*STP	ST1 ^(Note 1)	*STP	ST1 ^(Note 1)	ST1 ^(Note 1)	*STP	
5	GN		2	RES		SPDC (RES) ^(Note 2)		CN1 (RES) ^(Note 2)		RES	ST2(RES) ^(Note 2)	RES
6	BL		3	- /SON		- /SON		- /SON		- /SON	- /SON	- /SON
7	PL	O U T	0	LS0/PE0	LS0/PE0	LS0/PE0	LS0/PE0	LS0/PE0	LS0/PE0	LS0/PE0	LS0/PE0	
8	GY		1	LS1/PE1	LS1/PE1	LS1/PE1	LS1/PE1	LS1/PE1	LS1/PE1	LS1/PE1	LS1/PE1	
9	WT		2	HEND/SV	HEND/SV	HEND/SV	HEND/SV	LS2/PE2	LS2/PE2	LS2/PE2	HEND/SV	
10	BK		3	*ALM/SV	*ALM/SV	*ALM/SV	*ALM/SV	*ALM/SV	*ALM/SV	*ALM/SV	*ALM/SV	

(Note 1) : It is invalid before home-return operation.

(Note 2) : The description in the brackets shows the condition before the home return operation.

(Note 3) : *STP and *ALM are the signals that are negative logic.

(Reference) Signal of Active Low

Signal with "*" expresses the signal of active low. A signal of active low is a signal that the input signal is processed when it is turned off, output signal is ordinary on while the power is on, and turns off when the signal is output.

(3) List of PIO Signal Functions

Signal Type	Symbol	Signal Name	Function	
Power Input	24V	I/O Power Supply +	It is the common power source for I/O circuit. The positive (+) side of 24V DC is connected.	
	0V	I/O Power Supply –	It is the common power source for I/O circuit. The positive (–) side of 24V DC is connected.	
Input	ST0	• Movement Signal [Single Solenoid System]	The positioning to the corresponding target position is performed, when the signal leading edge created in the mode change from OFF to ON, or ON level is detected.	
		• Backward Position Movement Signal [Double Solenoid System]		
		• Movement Signal 1 [PIO Pattern 3]		
	ST1	• Forward Position Movement Signal		
		• Movement Signal 2 [PIO Pattern 3]		
	ST2	Intermediate Position Movement Signal		
	*STP	Pause Signal		When this signal is turned OFF the deceleration is stopped. When the signal is turned ON again, the movement is re-started.
	RES	Reset Signal		When the signal leading edge created in the mode change from OFF to ON, is detected, the currently issued alarm is reset. * Depending on the alarm level, alarm reset might not be available. Refer to the Trouble Shooting for the details.
	SON	Servo ON Signal		During the time when this signal is turned ON, the servo-motor is in the ON mode.
SPDC	Movement Speed Change Signal	When the movement speed is changed during the movement, do it with this signal turned ON. * This signal is effective when the PIO pattern 1 has been set.		
CN1	Target Position Change Signal	When the conditions for the positioning operation or pressing operation, etc., are changed to operate the system, turn ON this signal. When this signal is turned ON or OFF during the operation, the position data is changed. * This signal is effective when the PIO pattern 2 has been set.		
ASTR	Continuous Reciprocating Operation Signal	During the time when this signal is turned ON, the actuator's continuous reciprocating operation is performed between the forward position and the backward position. When this signal is turned OFF during the movement operation, after the actuator is positioned to the current target, it is stopped. * This signal is effective when the PIO pattern 5 has been set.		
Output	LS0	Backward Position Detection	The same operation as of the limit switch of the air cylinder is performed. It is turned ON when the current position is within the positioning width for each position detection output.	
	LS1	Forward Position Detection		
	LS2	Intermediate Position Detection		
	PE0	Backward Positioning Completion	This signal is turned ON when the current position goes within the positioning width, and the positioning to the target position is complete. It is turned OFF in the Servo-Motor OFF mode or the Emergency Stop Mode.	
	PE1	Forward Positioning Completion		
	PE2	Intermediate Positioning Completion		
	HEND	Home Return Completion	This signal is turned ON when the home return operation is completed.	
	SV	Servo ON Signal	This signal is turned ON when the servo-motor is turned ON and driving is enabled.	
	*ALM	Alarm Output Signal	This signal is turned ON when the controller is in the normal condition and turned OFF when the controller is in the alarm condition. In such case, monitor this signal in the PLC and take an appropriate measure.	

 **Note** For the PLC Input signal, keep it ON for at least 7ms or more.

ASEP/PSEP/DSEP

2.3 Circuit Diagram (Example)

[1] Power/Emergency Stop Circuit

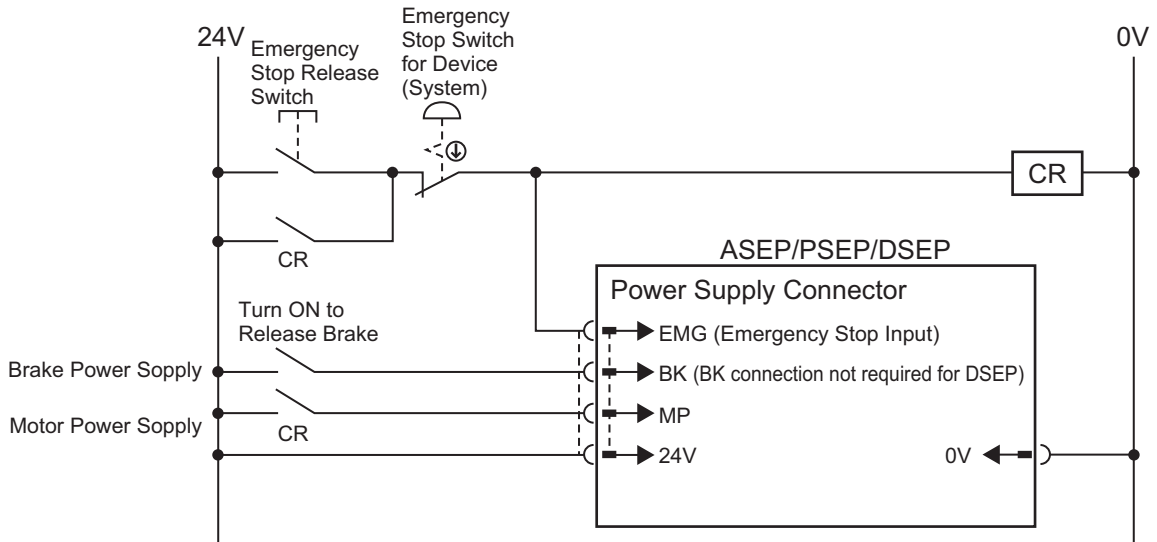

[2] Pattern 0 : Point-to-Point Movement (Standard)

1) Single Solenoid System

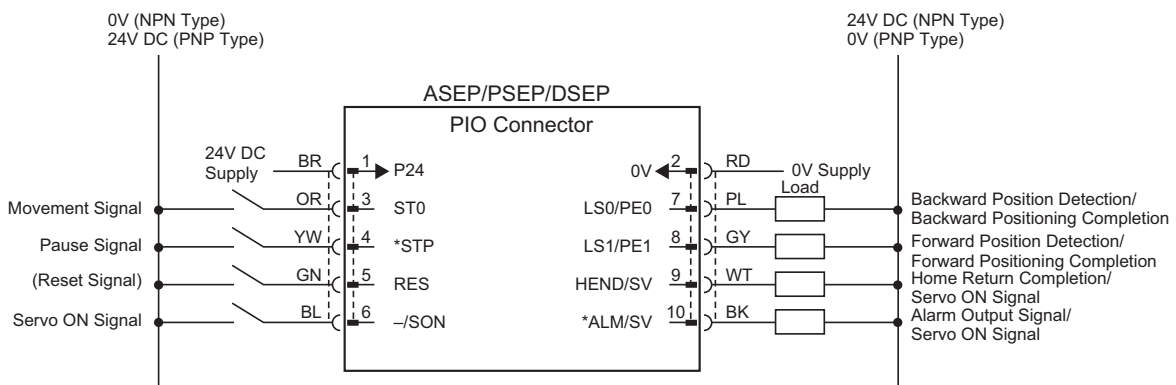

2) Double Solenoid System

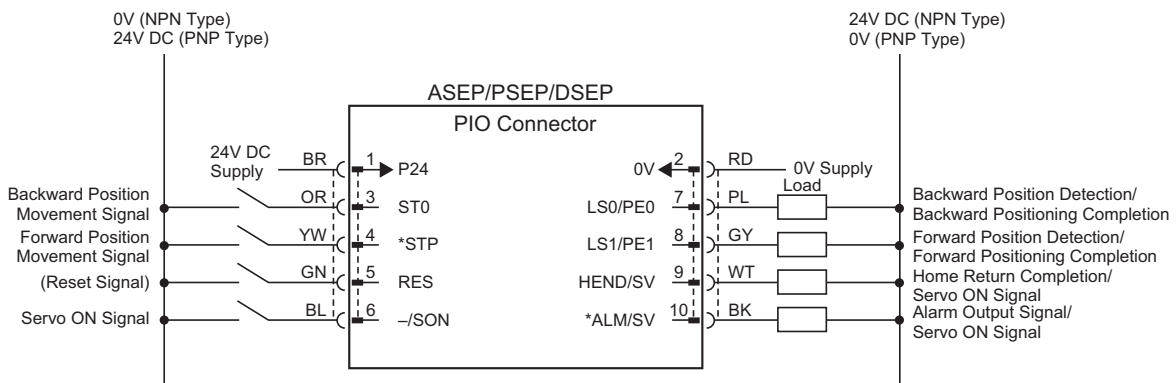

ASEP/PSEP/DSEP

[3] Pattern 1 : Point-to-Point Movement (Movement Speed Change)

1) Single Solenoid System

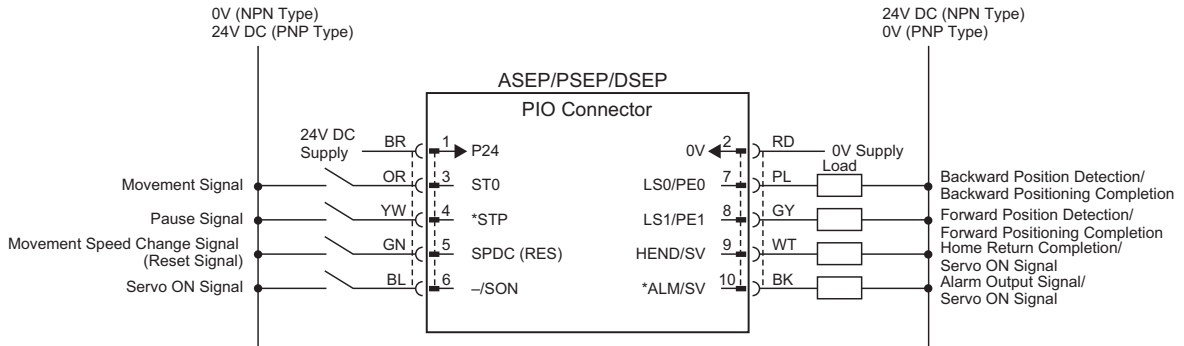

2) Double Solenoid System

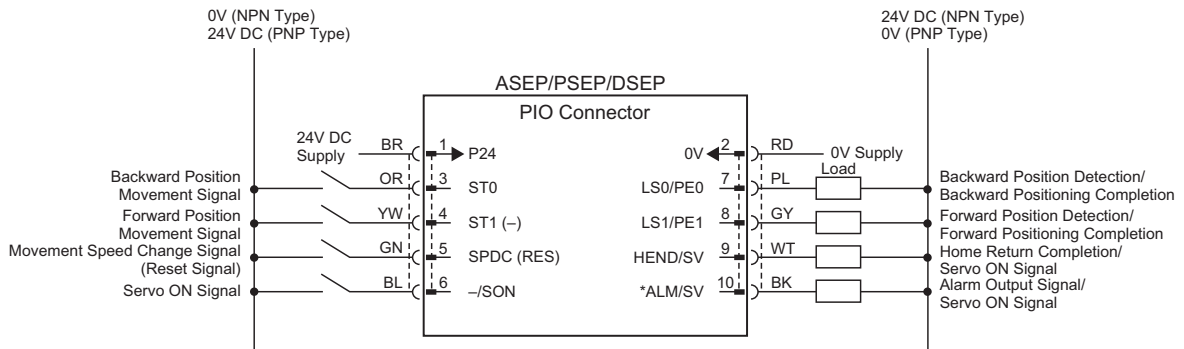

ASEP/PSEP/DSEP

[4] Pattern 2 : Point-to-Point Movement (Target Position Change)

1) Single Solenoid System

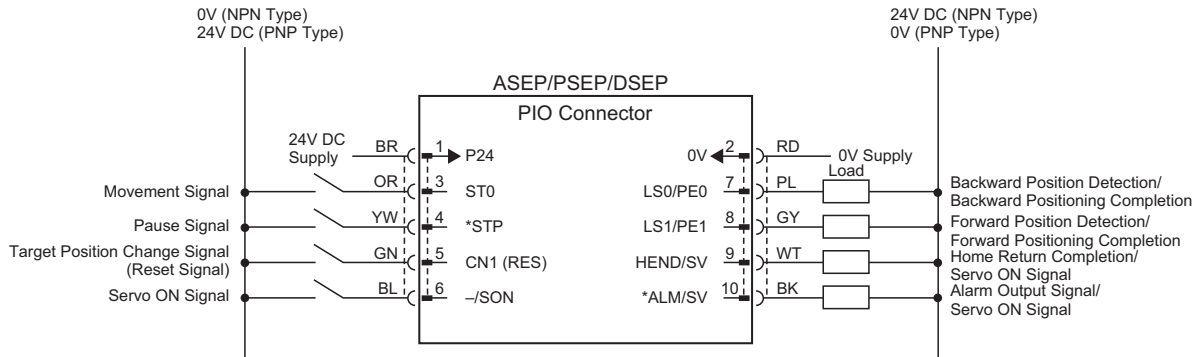

2) Double Solenoid System

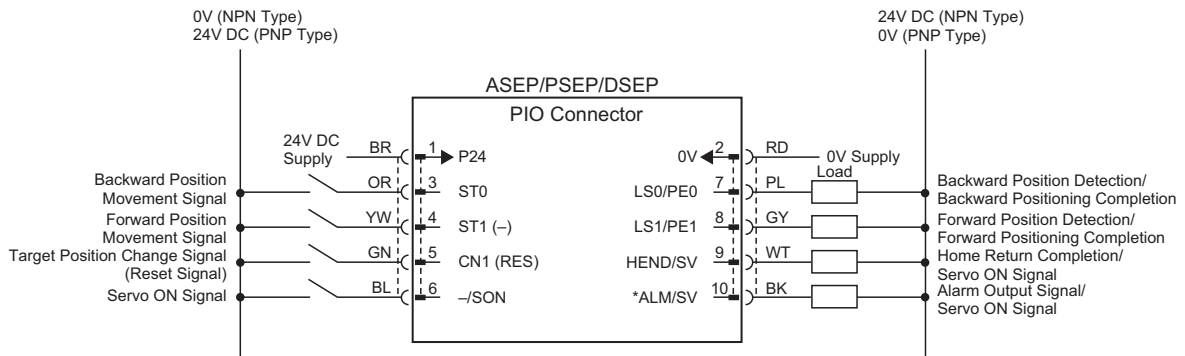

ASEP/PSEP/DSEP

[5] Pattern 3 : 3-Point Movement (2-Input)

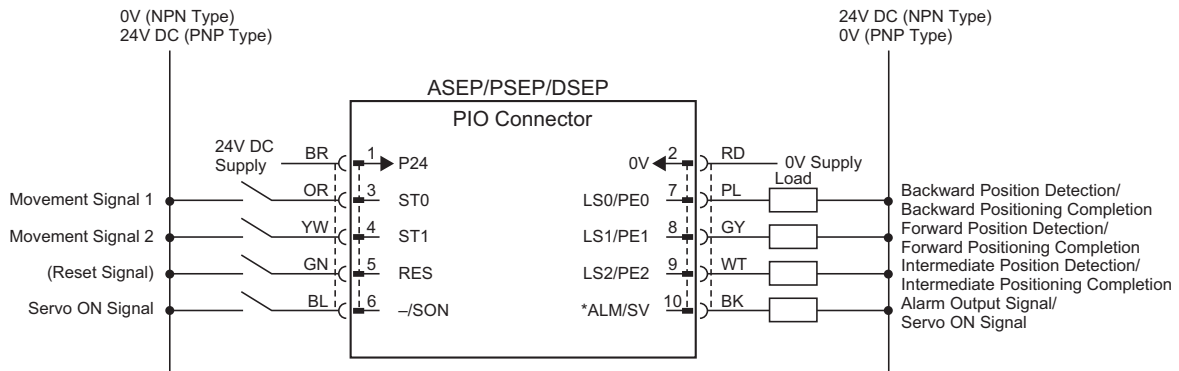

[6] Pattern 4 : 3-Point Movement (3-Input)

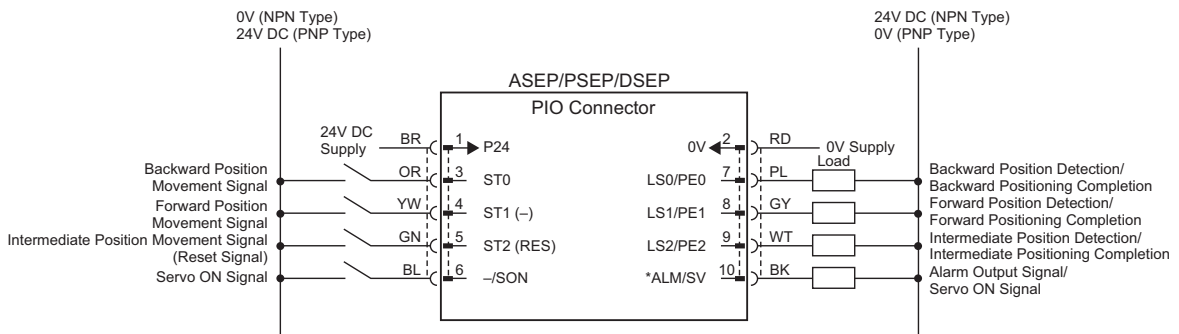

[7] Pattern 5 : Point-to-Point Reciprocating Movement (Continuous Reciprocating Operation)

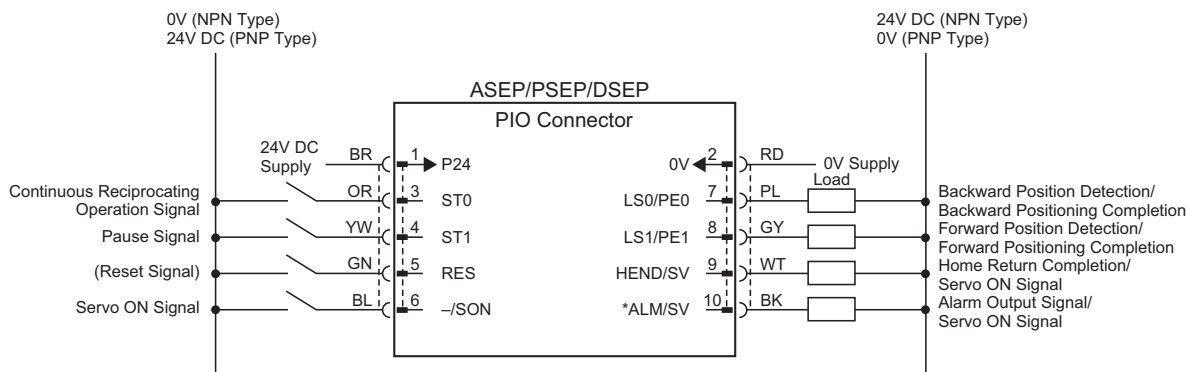

ASEP/PSEP/DSEP

[9] Motor • Encoder Connector

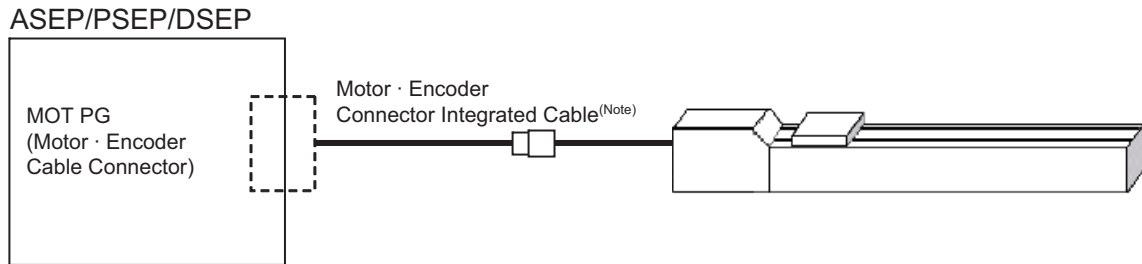

(Note) Motor • Encoder Connector Integrated Cable is an accessory of the actuator.

□□□ : Cable Length Example) 030 = 3m

- CB-ACS-MPA (for RCA2, RCL)
- CB-APSEP-MPA (for RCA2, RCL)
- CB-CA-MPA (for RCD)
- CB-ASEP-MPA (for RCA)
- CB-PCS-MPA (for RCP3)
- CB-APSEP-MPA (for RCP3)
- CB-RPSEP-MPA (for RCP2 Small Rotary)
- CB-PSEP-MPA (for RCP2 (except for Small Rotary))

⚠ Note: Connection to the Existing ROBO Cylinder
 For the connection to the existing ROBO Cylinder Series actuators, please purchase and prepare a connection cable separately from the following table.

ROBO Cylinder Series that you may already have	Connection Cable (to be purchased separately) □□□ shows the cable length. (Example : 050=5m)	Applicable Controller
RCP2(except for Small Rotary Type)	CB-PSEP-MPA□□□	PSEP
• Small Rotary Type RCP2-RTBS RCP2-RTBSL RCP2-RTCS RCP2-RTCSL	CB-RPSEP-MPA□□□	
RCP3	CB-APSEP-MPA□□□	ASEP, PSEP
RCA2, RCL	Extension Cable : CB-APSEP-MPA□□□JY(JYP)	
RCA	CB-ASEP-MPA□□□	ASEP

[10] Connection to Absolute Battery Unit (Limited only to ASEP/PSEP applicable for Simple Absolute Type)

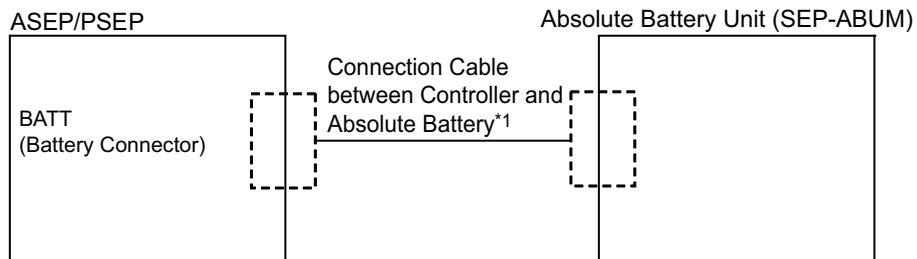

*1 Connection Cable between Controller and Absolute Battery

CB-APSEP-ABM005 ••• Applicable Controller : ASEP-C-□-□-□-0-ABUM□
 PSEP-C-□-□-□-0-ABUM□

CB-APSEP-AB005 ••• Applicable Controller : ASEP-C-□-□-□-0-ABU□
 (Existing models: Not complied with UL) PSEP-C-□-□-□-0-ABU□

2.4 Wiring Method

2.4.1 Wiring Layout of Power Supply Connector

The wires of the power supply and the emergency stop circuit are to be connected to the enclosed connector (plug).

Strip the sheath of the applicable wires for 7mm and insert them to the connector. Push a protrusion beside the cable inlet with a small slotted screwdriver to open the inlet. After inserting a cable, remove the screwdriver from the protrusion to fix the cable.

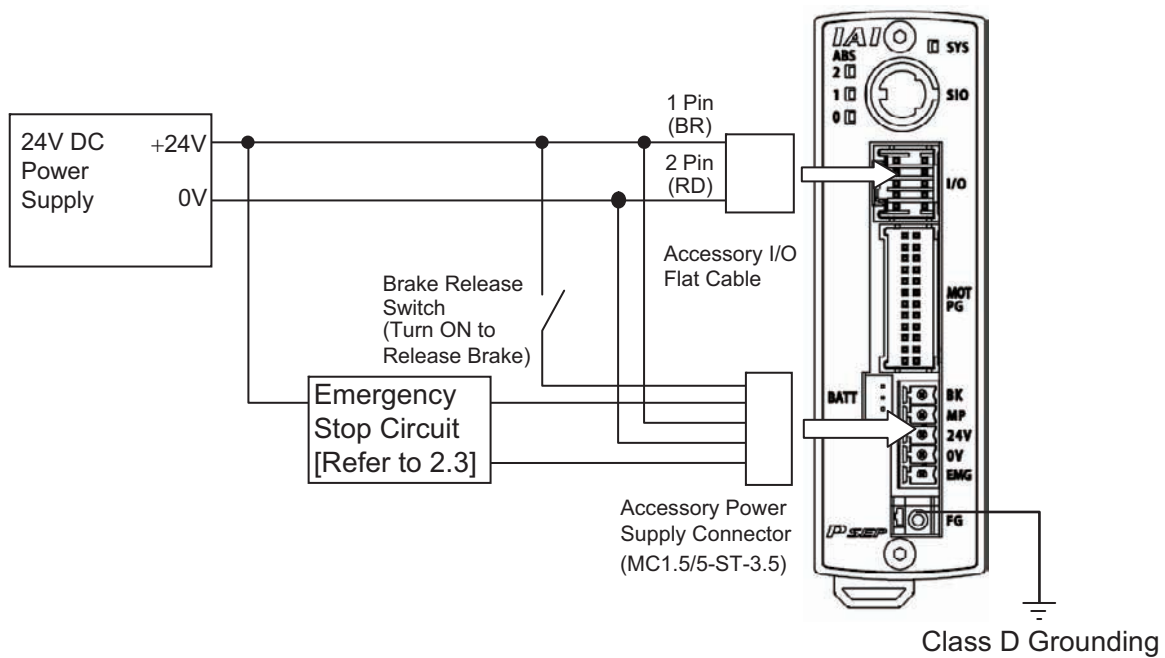

● Power Supply Connector

Connector Name	-	
Cable Side	MC1.5/5-ST-3.5	Standard Accessory
Controller Side	MC1.5/5-G3.5	

Pin No.	Signal Name	Contents	Applicable Wire Diameter
1	EMGIN	Input of Emergency Stop Status Signal ^(Note 1)	KIV0.5mm ² (AWG20)
2	0V	Power Supply Input (24V DC ±10%)	KIV1.25mm ² (AWG16)
3	24V		
4	MP	Motor Driving Power Supply Line	KIV1.25mm ² (AWG16)
5	BK	Brake Forced Release Power Supply Input ^(Note 2) (24V DC ±10% 150mA)	KIV0.5mm ² (AWG20)

(Note 1) The emergency stop status signal input determines as the system is in normal condition when 24V DC is input and in emergency stop when 0V is input. Once in emergency stop, the actuator stops its operation and turns the servo off.

Construct the emergency stop circuit suits for the safety category considering the entire system.

(Note 2) The brake is compulsorily released when +24V is supplied. Make the 0V in common with the 0V of the power input. Do not apply on DSEP.

2.4.2 Wiring Layout of FG Terminal Block

FG is to be connected to a screwless terminal block.

Strip the sheath of the applicable wires for 11mm and insert them to the connector. Push a protrusion beside the cable inlet with a small slotted screwdriver to open the inlet. After inserting a cable, remove the screwdriver from the protrusion to fix the cable.

- FG Terminal Block

Terminal Block Name	FG	
Controller Side	ML-800-S1H1P	

Pin No.	Signal Name	Contents	Applicable Cable
1	FG	Ground Cable Connection	KIV1.25mm ² (AWG16)

2.4.3 Connection to Actuator

Connect the cables to the motor • encoder connectors.



Note:

For Simple Absolute applicable type, remove the absolute battery connector from the controller before connecting the cable.

• Motor • Encoder Connector Specifications

Connector Name	MOT PG	
Cable Side	PADP-24V-1-S	
Controller Side	S24B-PADSS-1	

Pin No.	Signal Name			Contents	Applicable Wire Diameter
	ASEP	PSEP	DSEP		
1	U	ϕ A	U	Motor Driving Line	Cable dedicated for IAI products
2	V	VMM	V		
3	-	ϕ B	-		
4	-	VMM	-		
5	W	ϕ /A	W		
6	-	ϕ /B	-		
7	BK+	LS+	-	LS* : Home Position Confirmation Sensor BK* : Brake Power Supply	
8	BK-	LS-	-		
9	LS+	BK+	LS+		
10	LS-	BK-	LS-		
11	ENA	-	ENA	EN* : Encoder Signal HS* : Hall IC Signal	
12	/ENA	-	/ENA		
13	ENB	ENA	ENB		
14	/ENB	/ENA	/ENB		
15	ENZ	ENB	HS1		
16	/ENZ	/ENB	HS2		
17	5V	5V	5V	Encoder Power Supply	
18	/PS	VPS	-	Encoder Line Driver Enable Output	
19	GND	GND	GND	Ground	
20	LSGND	LSGND	HS3	LSGND : Ground for Limit Switch HS3 : Hall IC Signal	
21	NC	NC	NC	Disconnected	
22	NC	NC	NC	Disconnected	
23	NC	NC	NC	Disconnected	
24	FG	FG	FG	Ground	

ASEP/PSEP/DSEP

2.4.4 Connection of PIO

Conduct the connection of I/O to the controller is to be carried out using the dedicated I/O cable. The cable length is shown in the model code of the controller. Please check the controller model code. There are 2m for standard, 3m and 5m as an option. 10m is also applicable at maximum if purchased separately. [Refer to “1.1.5. How to read the model”]

Also, the end of the cable harness to be connected to the host controller (PLC, etc.) is just cut and no treatment is conducted so the wiring layout can be performed freely.

Model : CB-APSEP-PIO□□□□···For ASEP-C, PSEP-C

(□□□ shows the cable length L Example.020=2m)

- PIO Connector

Applied Connector	55959-1030	Manufactured by MOLEX
Connector Name	I/O	PIO Connector
Connection Cable	Dedicated Cable [refer to (3) in this section.]	Enclosed in this controller

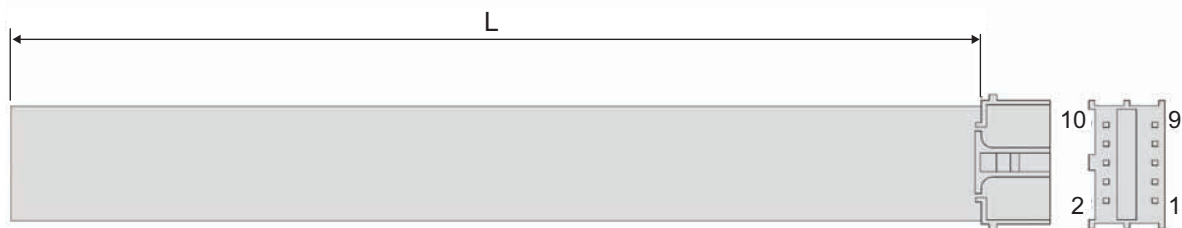

Model : CB-APSEPW-PIO□□□□···For ASEP-CW, PSEP-CW

(□□□ shows the cable length L Example.020=2m)

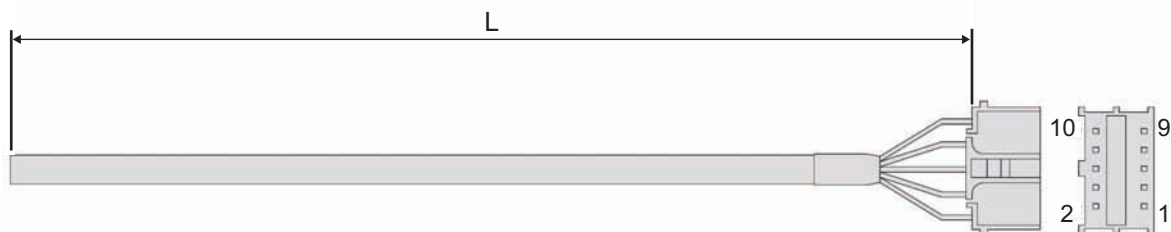

No.	Connector		Signal Name
	Color		
	CB-APSEP-PIO□□□□	CB-APSEPW-PIO□□□□	
1	BR	BR	24V
2	RD	BR, WT	0V
3	OR	RD	IN0
4	YW	RD, WT	IN1
5	GN	YW	IN2
6	BL	YW, WT	IN3
7	PL	GN	OUT0
8	GY	GN, WT	OUT1
9	WT	BK	OUT2
10	BK	BK, WT	OUT3

2.4.5 SIO Connector Connection

SIO connectors can be used not only for the connection of teaching tool, but also for the connection of the host controller (PLC, touch panel and PC).

For the operation, refer to the instruction manual of each module.

[Refer to Instruction manuals related to this product, which are contained in CD/DVD.]

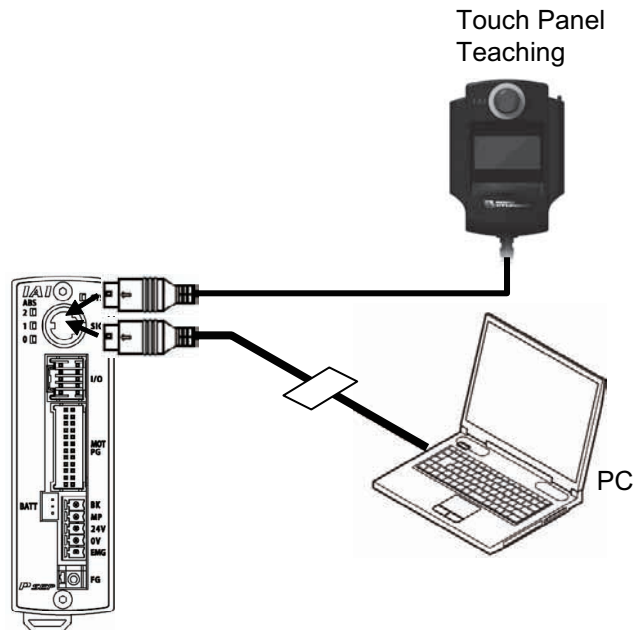

⚠ Note:

If the teaching pendant is removed with the power supply being on, the condition will become the transient emergency stop and the operated actuator will stop.

Do not disconnect the teaching pendant during the operation.

2.4.6 Battery Connector Connection (For Simple Absolute Type)

The absolute battery unit is to be connected to the battery connector.

Connect the dedicated cable enclosed with the absolute battery unit.

Connection Cable between Controller and Absolute Battery : CB-APSEP-AB005

Applicable Controller ASEP- □ - □ - □ -0-ABUM

 PSEP- □ - □ - □ -0-ABUM

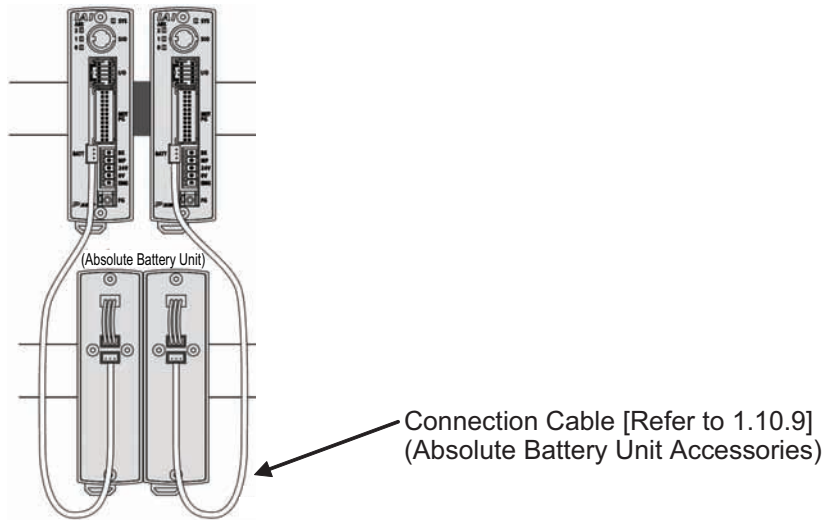

- Battery Connector

Applicable Connector	53015-0310 (Model: ABUM, ABUNM)	Manufactured by Molex
	S3B-PH-K-S (LF) (SN) (Model: ABU, ABUN)	Manufactured by JST
Connector Name	BATT	Battery Connector
Connection Cable	Dedicated Cable	Enclosed in the absolute battery unit

Pin No.	Signal Name	Contents
1	BT	Negative Side of Battery Power Supply
2	GND	Positive Side of Battery Power Supply
3	BTMP	For Battery Temperature Detection

A SEP/P SEP/D SEP

Battery

Name	NiMH battery (SANYO Electric Co., Ltd.)
Model	AB-7
Rated	3.6V 3300mAh
Battery Life (reference)	Approximately 3 years (It may vary depending on the usage condition.)
Charging Time	Approximately 72 hours

 **Note: About Battery Charge and Discharge**

When using for the first time or the first time after the battery is replaced, do not charge the battery for more than 72 hours in a row.

The battery can be charged when 24V is supplied to the controller.

The encoder data will be able to be retained for the duration ^(Note) stated below as per hour of battery charge.

The data will be lost if the controller is turned OFF for longer than the data retained duration. Start charging the battery as early as possible.

The battery has a limited product life and the data retained duration will gradually decrease. If a sudden huge decrease started to occur to the retained duration, replace the battery.

(Note) Data Retained Duration per Hour Battery Charge

* The values stated below are the reference values of when the battery is new.

Setting in user parameter No. 19	0	1	2	3
Data Retained Duration (reference)	6.6H	5.0H	3.3H	1.6H

[Refer to section 3.4 for the user parameter No.19.]

3. Operation

3.1 Setting

3.1.1 Initial Setting

Conduct the following initial settings on the PC software or Touch Panel Teaching.

Refer to the Instruction Manual for the PC software or Touch Panel Teaching for the details of the settings.

• Initial Setting Items

* There may be some items that are not displayed depending on the selected operation patterns.

No.	Setting Items	Setting Range (Set in delivery)	Contents	PIO Pattern					
				0	1	2	3	4	5
1	PIO Pattern (Operation Pattern)	0 to 5 (0)	Set it to the pattern to be used.	○	○	○	○	○	○
2	Operation Mode (Solenoid System)	Single/Double (Double)	It is selectable only when the PIO pattern is set to "0", "1" or "2". Select "Single" (Single Solenoid System) or "Double" (Double Solenoid System).	○	○	○			
3	Stop Signal	Enable/Disable (Disable)	It is selectable only when "Single" is selected in "2. Operation Mode (Solenoid System)". When the PAUSE signal (*STP) is used, select "Enable".	○	○	○			○
4	Input Signal System (Solenoid Type)	Continuous Operation Type /Momentary Operation Type (Continuous Operation Type)	It is selectable only when "Double" is selected in "2. Operation Mode (Solenoid System)". For the signal sent from PLC to ASEP, PSEP or DSEP, select "Continuous Operation" (level signal) or "Momentary Operation" (edge signal).	○	○	○		○	
5	Intermediate Stop System	Both Solenoids ON /Both Solenoids OFF (Both Solenoids OFF)	It is selectable only when the PIO pattern is set to "3". In the case the same use procedure as for 5-port 3-position electromagnetic valve is applied, select "Both Solenoid OFF". In the case that the same use procedure as the time when two units of the 3-port single solenoid electromagnetic valve, are used, select "Both Solenoid ON".				○		
6	Servo-motor Control	Enable/Disable (Disable)	When "Disable" is selected, the servo-motor is automatically turned ON after the power input. When "Enable" is selected, the servo-motor is turned ON by means of turning ON the SON signal on INPUT IN3.	○	○	○	○	○	○
7	Home Position Operation (Home Return Operation Procedure)	AUTO/MANU (MANU)	If AUTO is selected, the home-return operation is started automatically when the servo is turned for the first time after the power is supplied. When "MANU" is selected, the home return operation is performed with the first ST0 input.	○	○	○	○	○	○

A SEP/P SEP/D SEP

No.	Setting Items	Setting Range (Set in delivery)	Contents	PIO Pattern						
				0	1	2	3	4	5	
8	Output Signal Type	Limit Switch /Positioning (Limit Switch)	<p>The actuator is moved and the signal output system after the positioning completion is selected.</p> <ul style="list-style-type: none"> • Limit Switch :When the actuator reaches the target position, it is turned ON. (Even when the servo-motor is turned ON and if the current position is within the positioning width, the ON mode is continued. <p>In the Intermediate Position, when the actuator pass through the point, the position is within the range (within the positioning width), it is turned ON. Intermediate Position is reached.:LS2 ON Forward Position is reached. :LS1 ON Backward Position is reached. :LS0 ON</p> <ul style="list-style-type: none"> • Positioning :When the actuator reaches the target position, it is turned ON. (When the servo-motor is turned OFF, this signal is turned OFF. When the servo-motor is turned ON again and the current position is within the positioning width, it is turned ON. <p>Intermediate Position is reached. :PE2 ON Forward Position is reached. :PE1 ON Backward Position is reached. :PE0 ON</p>							
9	Output Signal Selection	0 to 2 (0)	<p>When "Enable" is selected for "6. Servo-motor Control", select whether or not the servo-motor ON signal STATUS is output.</p> <p>Select the following combination parameter "0", "1" or "2", when the PIO pattern "0", "1", "2" or "5" is selected.</p> <p>0: OUT2 = HEND OUT3 = *ALM (There is no "Servo-motor ON" signal output)</p> <p>1: OUT2 = SV, OUT3 = *ALM 2: OUT2 = HEND, OUT3 = SV</p> <p>Select the following combination parameter "0" or "1", when the PIO pattern "3" or "4" is selected.</p> <p>0: OUT3 = *ALM (There is no "Servo-motor ON" signal output)</p> <p>1: OUT3 = SV</p> <p>* When "Disable" is selected for "6. Servo-motor Control", this signal is allocated to "0" (There is no "Servo-motor ON" signal output).</p>							

3.1.2 Position Data Setting

Set the following items in the position data editing window of the PC software menu or by selecting “Position Setting” in the Touch Panel Teaching menu. [Refer to the PC Software or Touch Panel Teaching Instruction Manual for the details]

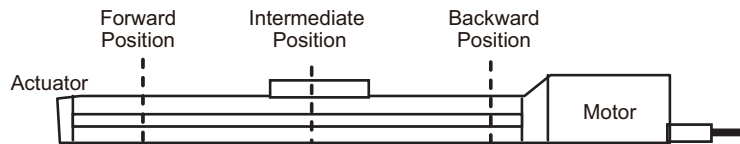

Position Data

Position Data	1) Position	2) Velocity	3) Acceleration	4) Deceleration	5) Pressing Force	6) Pressing Band	7) Energy-Saving Function
Forward Position	200.00	50.00	0.1	0.1	70	1.00	Effective
Backward Position	0.00	50.00	0.1	0.1	0	0	Effective
Intermediate Position	100.00	50.00	0.1	0.1	0	0	Effective

- 1) Position ... Set the position where the actuator is moved.
Setting Range : 0 to Actuator Stroke Range (Unit 0.01mm)

Operation Pattern Name : PIO Pattern No.	Displacement	Set Position		
		Forward Position	Backward Position	Intermediate Position
Standard Point-to-Point Movement :0	Point-to-Point Movement	<input type="radio"/>	<input type="radio"/>	
Movement Speed Setting :1	Point-to-Point Movement	<input type="radio"/>	<input type="radio"/>	
Target Position Setting Change :2	Point-to-Point Movement	<input type="radio"/>	<input type="radio"/>	
2-Input, 3-Point Movement :3	3-Point Movement	<input type="radio"/>	<input type="radio"/>	<input type="radio"/>
3-Input, 4-Point Movement :4	3-Point Movement	<input type="radio"/>	<input type="radio"/>	<input type="radio"/>
Continuous Reciprocating Operation :5	Point-to-Point Movement	<input type="radio"/>	<input type="radio"/>	

- 2) Velocity ... Set the actuator speed.
[Refer to Appendix in this manual or the Instruction Manual for the actuator.]
Setting Range : Actuator's min. speed to Actuator's max. speed
(Unit: 0.01mm/sec)
- 3) Acceleration ... Set the actuator acceleration.
[Refer to Appendix in this manual or the Instruction Manual for the actuator.]
Setting Range : 0.01 to Actuator's rated Value Range (Unit: 0.1G)
- 4) Deceleration ... Set the actuator deceleration.
[Refer to Appendix in this manual or the Instruction Manual for the actuator.]
Setting Range : 0.01 to Actuator's rated Value Range (Unit: 0.1G)

A SEP/P SEP/D SEP

⚠ Note:

Regarding to Acceleration/Deceleration Speed Setting

- (1) Do not have the setting to exceed the rated acceleration/deceleration speed that is specified in the catalog or this Instruction Manual. The setting that exceeds the rated acceleration/deceleration speed may shorten the actuator life remarkably.
- (2) Consider to lower the acceleration/deceleration speed when a shock or vibration is applied to the actuator or work. In such a case, keeping the use under such a condition may shorten the actuator life remarkably.

5) Pressing Force ... Set the pressing torque (current limit value) in % for the pressing operation. Having a bigger power limit value gives bigger pressing force.

It is set to the positioning operation when setting to "0".

[Refer to Appendix in this manual or the Instruction Manual for the actuator.]

Setting Range : 0 (pressing operation is disabled), 20 to 70%^(Note 1) (Unit: 1%)

It differs depending on the actuator.

[Refer to Appendix in this manual or the Instruction Manual for the actuator.]

6) Pressing Width ... Set the position for starting the pressing operation.

The position moved as much distance as the pressing width to the center from the movement target position (forward position or backward position), is regarded as the starting position, the pressing operation is started.

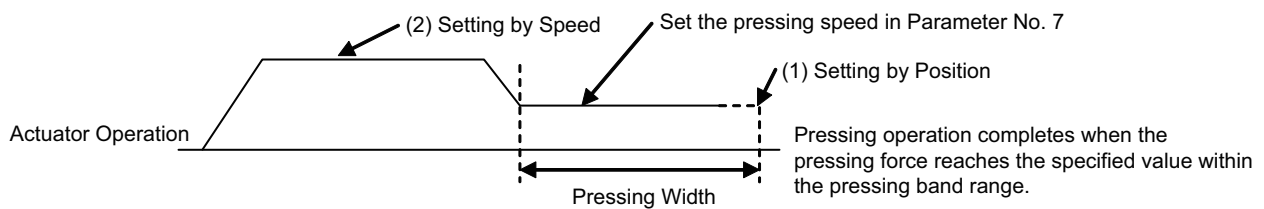

[Pressing towards Forward Position or Intermediate Position]

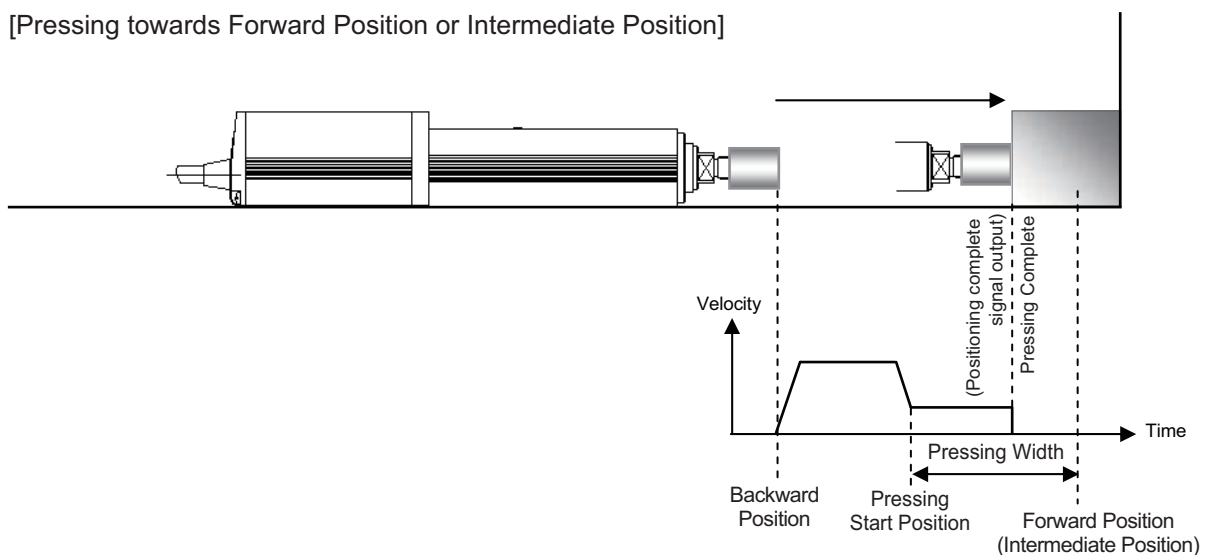

A SEP/P SEP/D SEP

[Pressing towards Backward Position or Intermediate Position = Pulling Action]

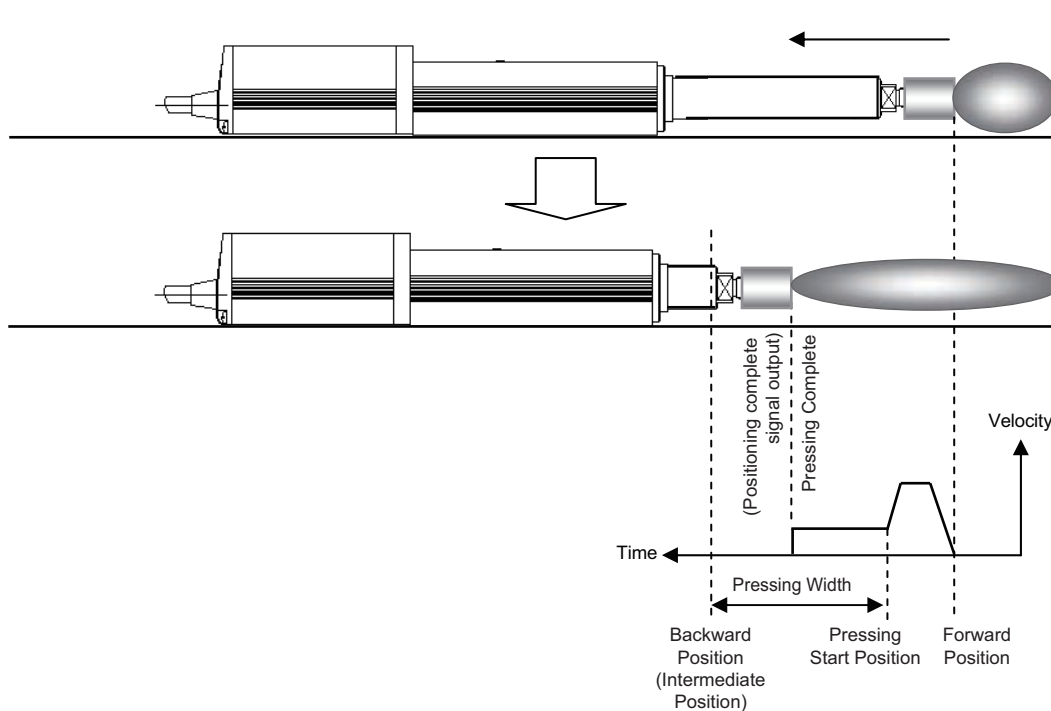

7) Energy-Saving Function ... When it is set to “Enable”, the servo-motor is turned OFF automatically after the positioning is completed and the specified time period passes.
 (Because the holding current does not pass in the stop mode, the power consumption can be saved).
 The servo-motor is turned ON with the next movement command, and the actuator movement is started.

- The movement speed is to be changed for the Operation Pattern (PIO Pattern) No.1, in addition to position data, the position where the speed is changed and the velocity parameters are set.

Position Data	8) Changed Position	9) Changed Speed
Forward Position	60.00	30.00
Backward Position	40.00	30.00

8) Changed Position... The position where the velocity is changed in the course of moving to the forward position or backward position, is set.

9) Changed Speed ... The changed speed is set.

A SEP/P SEP/D SEP

- When the position data is to be changed for the Operation Pattern (PIO Pattern) No. 2, in addition to the position data items for the forward position and backward position, the position data items for the changed forward position and changed backward position, are set.
- In the case that the CN1 is turned OFF, the position data for the Forward Position turns to be the data in Forward Position.
In the case of "ON", the position data for the forward position are the data specified in " Forward Position".
- In the case that the CN1 is turned OFF, the position data for the forward position turns to be the data in Backward Position.
In the case of "ON", the position data for the forward position are the data specified in " Backward Position".

Position Data	Position	Velocity	Acceleration	Deceleration	Pressing Force	Pressing Width	Energy-Saving Function
<input type="checkbox"/> Backward Position	0.00	50.00	0.1	0.1	0	0	Effective
<input type="checkbox"/> Forward Position	200.00	50.00	0.1	0.1	70	1.00	Effective
<input type="checkbox"/> Backward Position	10.00	50.00	0.1	0.1	0	0	Effective
<input type="checkbox"/> Forward Position	100.00	50.00	0.1	0.1	60	1.00	Effective

A SEP/P SEP/D SEP

3.1.3 Absolute Reset

(This function is effective only when the controller and actuator are the absolute type).

When the power to the machine is turned ON for the first time, perform the Absolute Reset.

Procedure: After the power is turned ON, an absolute encoder error detection error occurs. Turn ON the RES signal (IN2), reset the alarm on the alarm window displayed on the PC software, or touch "RES" on the Alarm window in the Touch Panel Teaching mode to remove the error. Then, perform the home return operation (In the case that the Absolute Reset has been performed, the home return window is not displayed).

3.2 Power-up and PIO Control

3.2.1 Control of Input Signal

The input signal of this controller has the input time constant of 7msec considering the prevention of wrong operation by chattering and noise.

Therefore, ensure the continuous signal for more than 7msec for each input signal. The signal cannot be identified if it is less than 7msec.

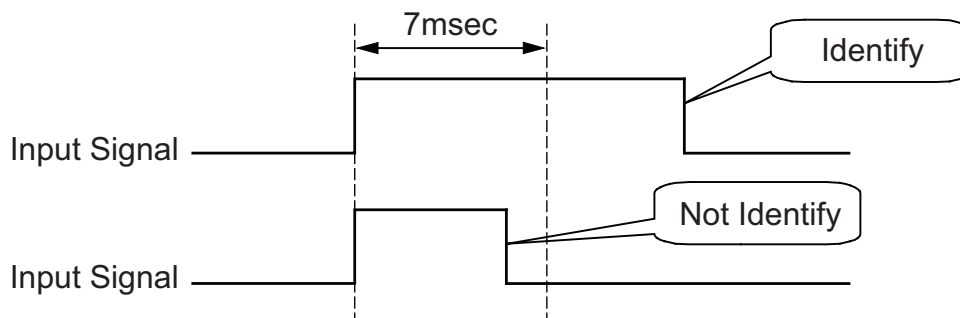

3.2.2 Power Input

- 1) Release the emergency stop status or enable the motor driving power supply.
- 2) Supply 24V DC for the I/O.
- 3) Supply 24V DC for the controller.
- 4) Input the Servo-motor ON signal from the PLC side^{(*)3}.
- 5) Input the Backward Position movement command and signals at first from the PLC side.

[Refer to 3.2.3 Home-return]

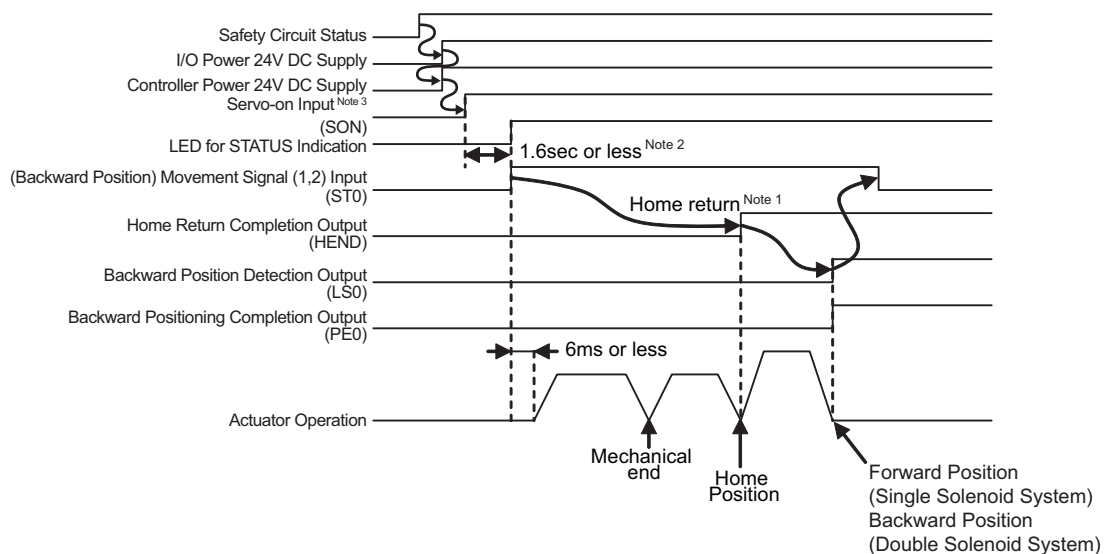

Note 1. When the home return operation is set to "MANU" in the initial setting and the first ST0 is turned ON, the actuator is returned to the home position and the operation is started.
When it is set to "AUTO", the actuator is returned to the home position automatically after the servo-motor ON is input.
The above are effective only when the actuator is incremental type (for the absolute type, the home return operation is not required).

Note 2. The Servo-motor ON signal is input for the first time after the power input, input the movement command after the delay time of 1.6sec or more.
In the second time or later, make the delay time of 60ms or more.

Note 3. When the Servo-motor Control is set to "Enable" in the initial setting, the servo-motor is turned ON by means of inputting the SON signal.
When it is set to "Disable" the servo-motor is turned ON automatically.

⚠ Warning: For ASEP and PSEP

The magnetic pole phase detection may not be performed normally if the servo is turned on near the mechanical end, and may cause such problems like an abnormal operation, magnetic pole not being defined or electromagnetic detection error.

Put it away from the mechanical end when turning the servo on.

3.2.3 Home-return

Home-return operation is performed when turning the Movement Signal 1 (ST0) on if the home return has not yet done since the power is turned on.

1) If the operation pattern is "Point-to-Point Movement (Single Solenoid)"

If the home return is not conducted on the operation panel yet, the first Movement Signal (ST0) will bring the actuator to the home position. After home return operation, it moves to the forward position and stops (for positioning).

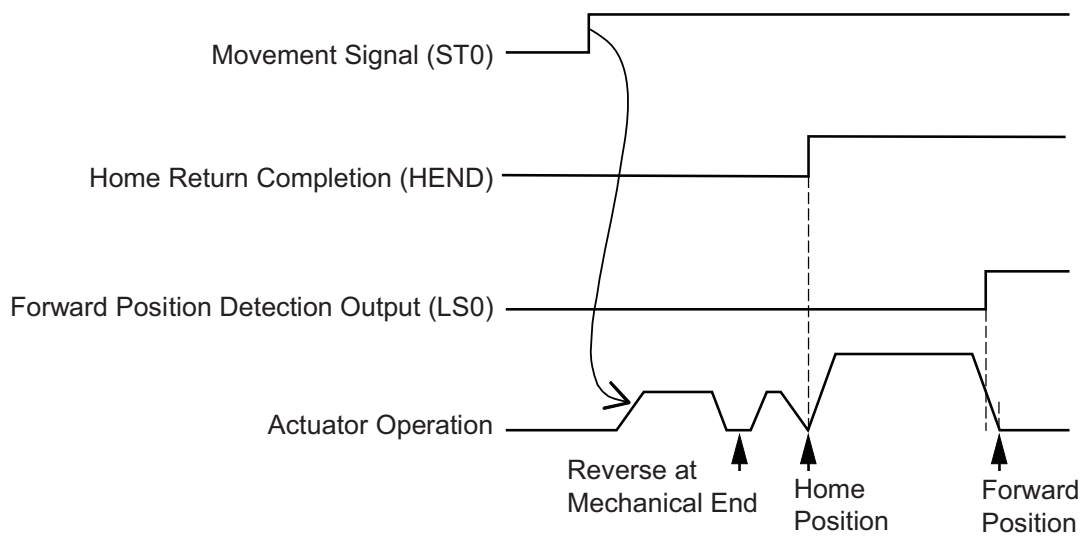

2) If the operation pattern is "Point-to-Point Movement (Double Solenoid) and 3-Point Movement"

After returning to home position, the actuator stops at the backward position (for positioning). (Home Return Completion)

Movement signal to the forward position (ST1) is invalid till the home-return operation is complete.

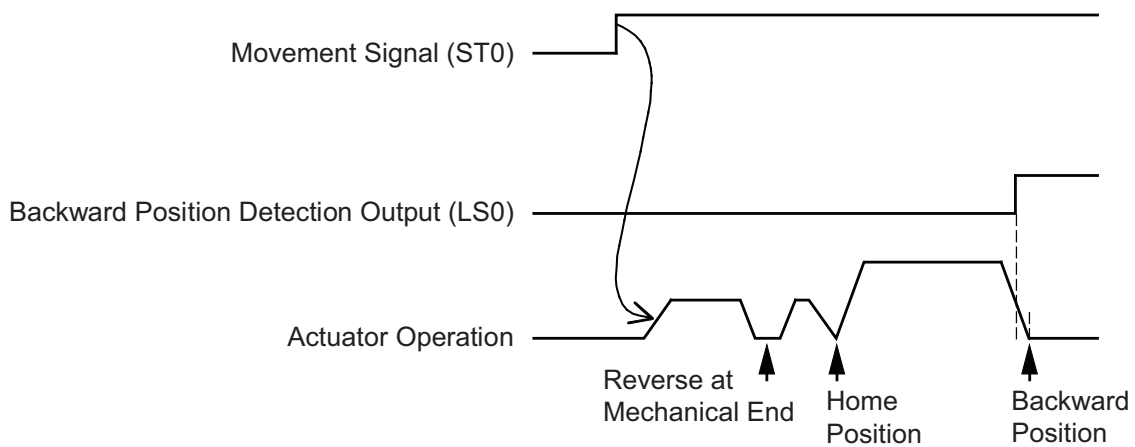

3.3 Timing Chart

[1] Point-to-Point Movement (For Single Solenoid System) ... PIO Pattern 0 to 2

When the ST0 is turned "ON", the positioning to the backward position is performed and when the ST0 is turned "OFF", the positioning to the forward position is performed.

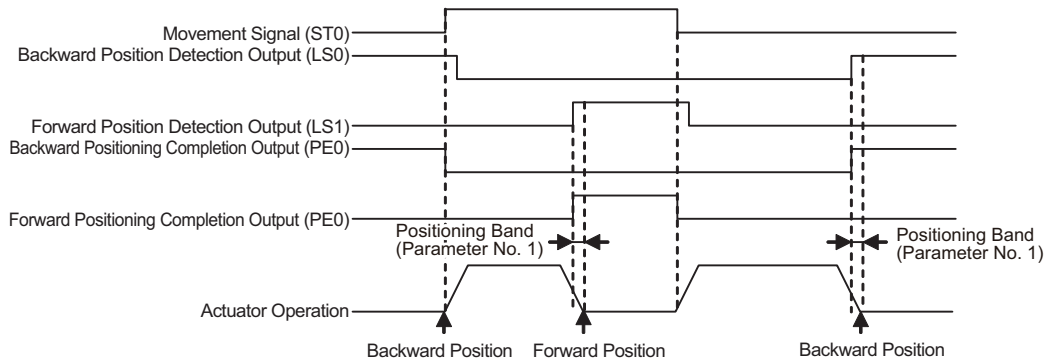

[2] Point-to-Point Movement (For Double Solenoid System) ... PIO Pattern 0 to 2

With the combination of ST0 and ST1, the actuator is moved to the target position.

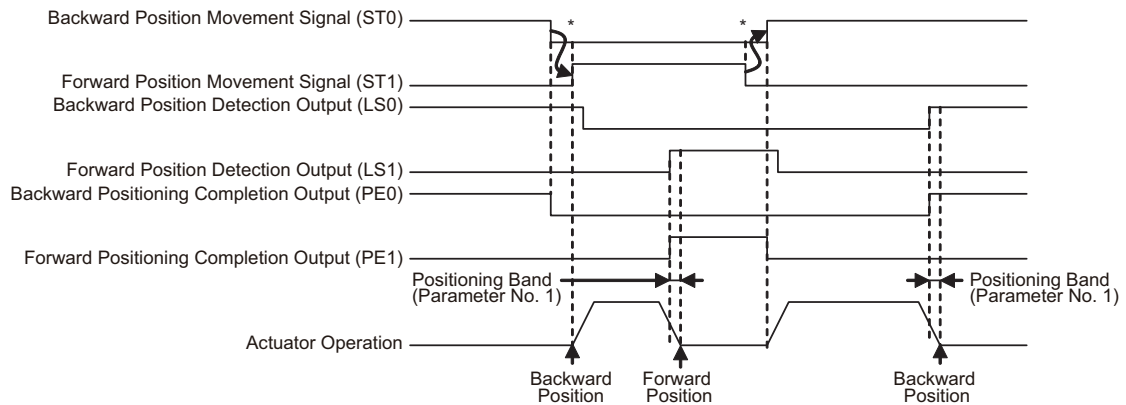

* The movement command is to be issued, make sure to turn OFF both ST0 and ST1 and issue the movement command to the target position.

If it is set to the continuous operation type in the initial setting, and both ST0 and ST1 are turned off during a movement, the actuator decelerates and stops on the spot.

If both ST0 and ST1 are turned on during a movement, the actuator operates following the signal that was previously on.

[3] Pause during Movement (For Single Solenoid System) ... **PIO Pattern 0 to 2**

* Inputting the STP signal pauses the actuator motion. A forward position movement example is shown as follows.

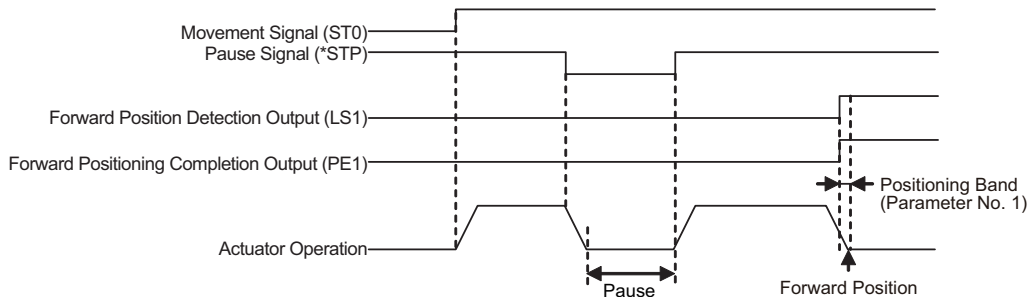

[4] Pause during Movement (For Double Solenoid System) ... **PIO Pattern 0 to 2**

The actuator motion is paused by means of turning OFF both of ST0 and ST1. The following figure shows an example of forward position movement.

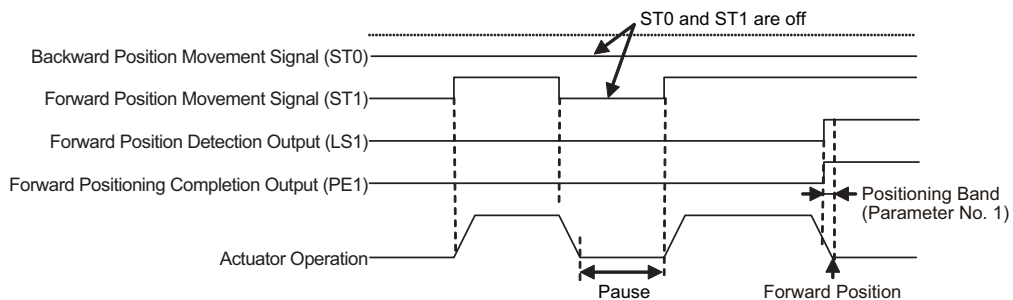

[5] Speed Change during the Movement (For Single Solenoid System) ... **PIO Pattern 1**

The movement speed is changed during the actuator's movement to the target position. When the movement command is issued with SPDC turned ON, the actuator is moved at the changed speed specified using the Speed Change function from the position set for the speed change in the position setting operation. The following figure shows an example of forward position movement.

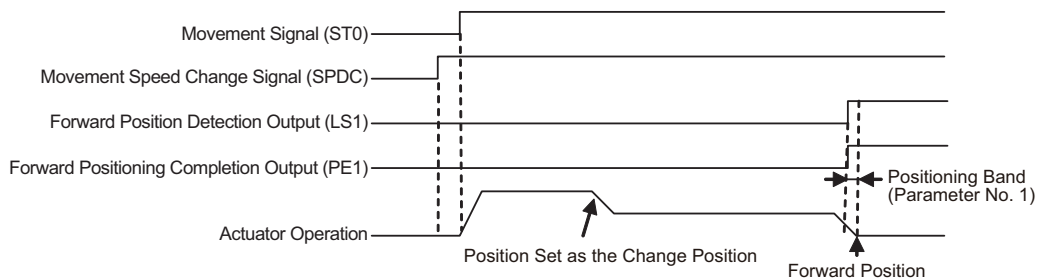

[6] Speed Change during the Movement (For Double Solenoid System) ... PIO Pattern 1

The movement speed is changed during the actuator's movement to the target position. When the movement command is issued with SPDC turned ON, the actuator is moved at the changed speed specified using the Speed Change function from the position set for the speed change in the position setting operation. The following figure shows an example of forward position movement.

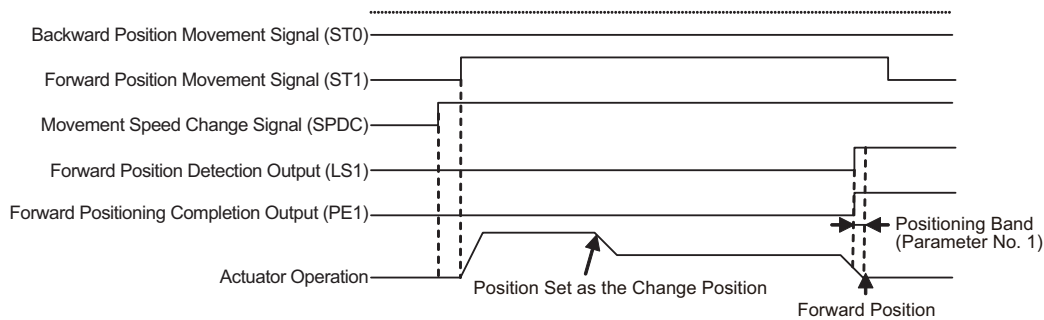

[7] Target Position Change (For Single Solenoid System) ... PIO Pattern 2

When the operation is to be performed with the two types of works set differently each other, the setting change is easy by means only of sending a single signal from PLC. When the movement command is issued after CN1 is turned ON, the actuator is moved using the Position Setting 3, in the case of moving to the forward position. In the case of moving to the backward position, the Position Setting 2 is used. The following figure shows an example of forward position movement.

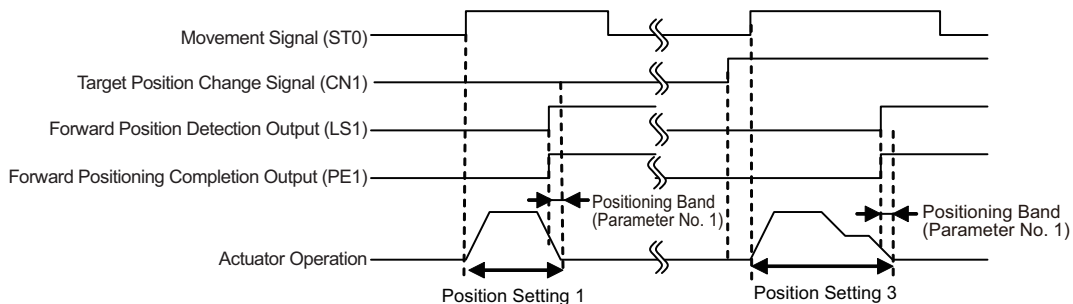

[8] Target Position Change (For Double Solenoid System) ... PIO Pattern 2

When the operation is to be performed with the two types of works set differently each other, the setting change is easy by means only of sending a single signal from PLC. When the movement command is issued after CN1 is turned ON, the actuator is moved using the Position Setting 3, in the case of moving to the forward position. In the case of moving to the backward position, the Position Setting 2 is used. The following figure shows an example of forward position movement.

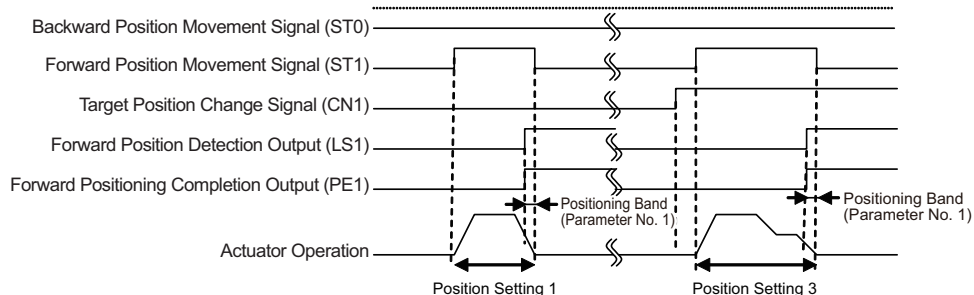

[9] 3-Point Movement (For Single Solenoid System) ... PIO Pattern 3

With the combination of ST0 and ST1, the actuator is moved to the target position.

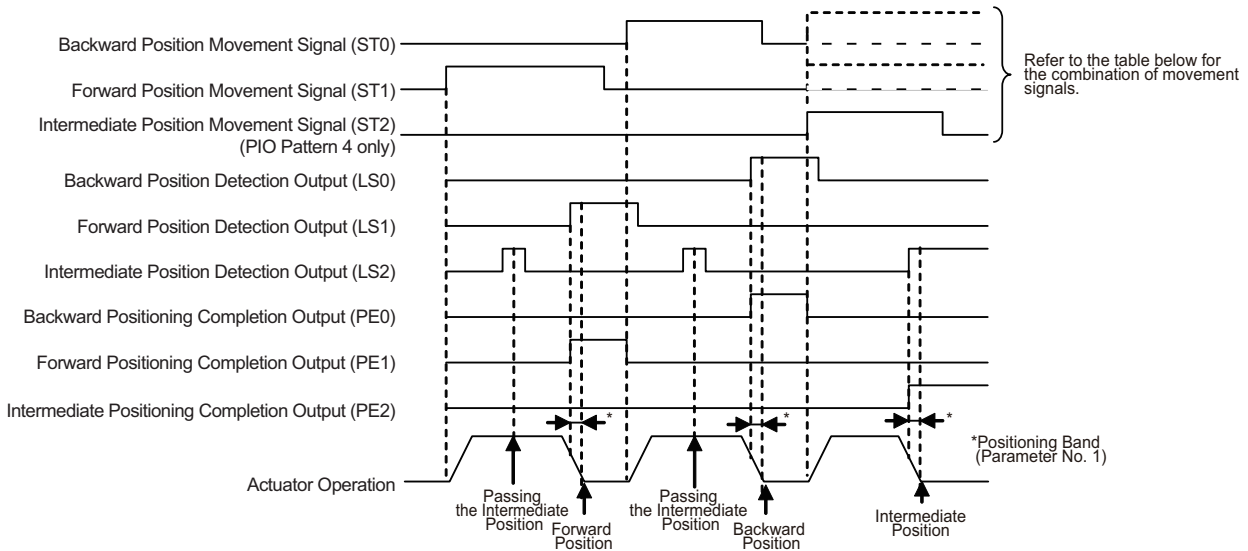

Following table shows the combination of the movement signals by each PIO pattern and the destination determined by it.

PIO Pattern 3			
Input Signal	Forward Position Movement	Backward Position Movement	Intermediate Position Movement
ST0	OFF	ON	Both being on or both off (selected in the initial setting)
ST1	ON	OFF	

PIO Pattern 4			
Input Signal	Forward Position Movement	Backward Position Movement	Intermediate Position Movement
ST0	OFF	ON	OFF
ST1	ON	OFF	OFF
ST2	OFF	OFF	ON

[10] Reciprocating Operation between 2 Points ... PIO Pattern 5

Reciprocating operation is performed continuously between the forward and backward positions while ASTR signal is ON.

Once ASTR signal is turned OFF, the actuator positions at the current target position and stops.

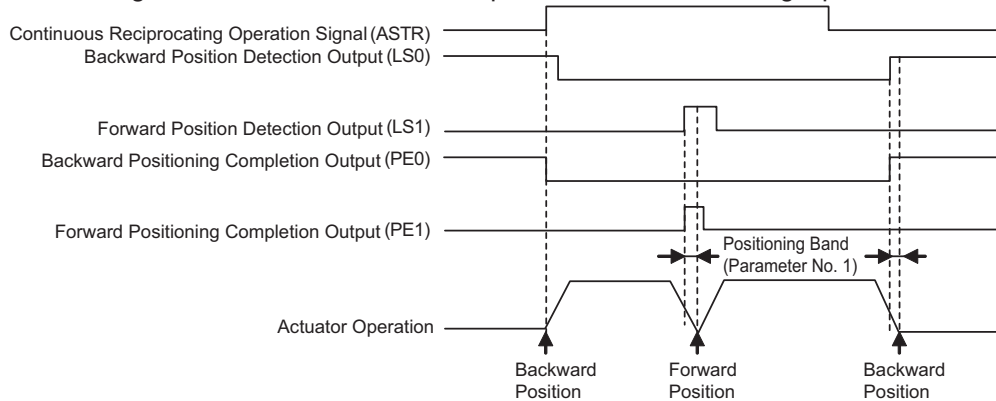

[11] Pressing Operation ... All PIO Patterns

If the pressing force and pressing band is set in the position data and perform a movement operation, the actuator performs a pressing movement towards the target position. The following shows the pressing operation towards the forward position as an example.

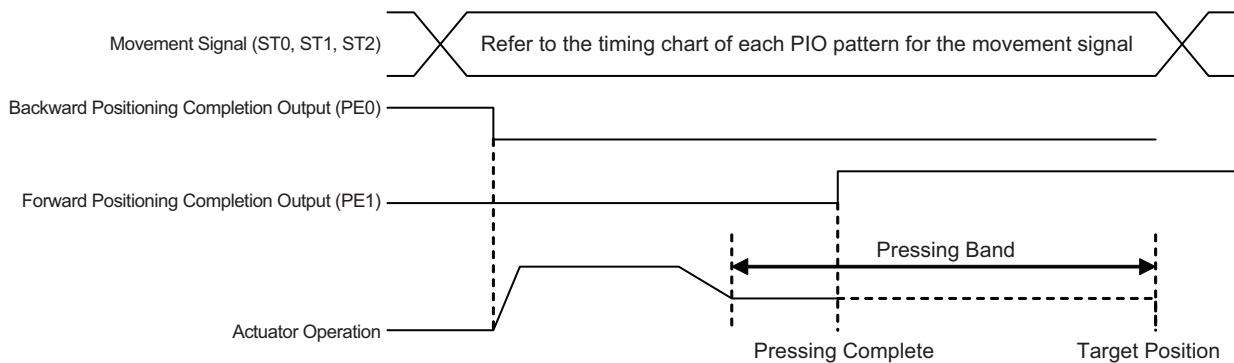

⚠ Note:

For the pressing operation, use the positioning complete signal (PE*).

Even the operation finishes with a miss-pressing and reaches the end point, PE* signal will turn ON. Set the pressing band wider when miss-pressing detection is required and identify with a timer.

3.4 User Parameters

No	Name	Initial Value	Setting Range	Remarks
1	Positioning Width [mm]	Dependent on Actuator	0.01 to Dependent on Actuator	Set the output range of LS signal and PE signal toward the target position.
2	Jog Speed [mm/sec]	Dependent on Actuator	0.01 to Dependent on Actuator	Set the movement speed in using the jog.
3	Servo-Motor Gain No.	6	0 to 31	These items are set to the standards when the machine is delivered. ^(Note 1) [Refer to 3.5]
4	Torque Filter Time Constant	Dependent on Actuator	0 to 2500	
5	Velocity Loop Proportional Gain	Dependent on Actuator	1 to 27661	
6	Velocity Loop Integrated Gain	Dependent on Actuator	1 to 217270	
7	Pressing Speed [mm/sec]	Dependent on Actuator	1 to Dependent on Actuator	Set the velocity in the pressing operation.
8	Pressing Stop Judgment Time [msec]	255	0 to 9999	Set the time period from hitting the work in the pressing operation to judged operation completion.
9	Current Limitation in Pressing and Bridging [0: Current limitation value while moving (ASEP, DSEP), Current limitation value while in operation stop (PSEP) 1: Current limitation value while pressing]	0	0 to 1	Set the torque after the actuator reaches the target position without hitting the work in the pressing operation in midway. * If set to 0, the current limitation value is different for ASEP/DSEP and PSEP.
10	Auto Servo-motor OFF Delay Time [sec]	1	0 to 9999	In the case that the energy-saving function is enabled, set the time period from positioning completion to automatic servo-motor turning OFF.
11	Stop Mode Selection [0: Complete Shutdown /1: Servo-Motor Stop]	0	0 to 1	It is effective only for PSEP. When "0" is selected, the current position is retained with the torque set with Parameter No.12, after the positioning operation. When "1" is selected, the current position is retained with the servo-motor control.
12	Current Limit Value in Positioning Stop [%]	35	0 to 70	It is effective only for PSEP. It is enabled when the Parameter No.11 is set to "0". When the value is increased, the stop holding torque is increased. In the case that a great external force is given when the actuator is stopped and knocking is caused, increase the value.
13	Current Limit Value in Home Return [%]	Dependent on Actuator	0 to 100	In the case that a sliding resistance is increased due to the load conditions, etc., in the vertical use, and the home return operation is completed at the position before the specified position, increase the value.
14	Automatic Positioning Execution Waiting Time [sec]	0.01	0.01 to 60.000	It is enabled when the PIO Pattern is set to "5". Set the duration after reaching the target position and before the movement starts toward the next target when the automatic operation signal (ASTR) is on.
15	Soft Limit [mm]	Dependent on Actuator	0.01 to 9999.99	Set the effective stroke range.
16	Home Return Offset Level [mm]	Dependent on Actuator	0.00 to Dependent on Actuator	It is changed when the fine adjustment is to be performed for the home position.
17	Home Return Direction [0: Reverse/1: Normal]	Dependent on Actuator	0 to 1	"Normal" shows the motor side and "Reverse" shows the opposite side of the motor. * For the rod type, the home return direction can not be changed.
18	Simplified Absolute Function [0: Disable/1: Enable]	Dependent on Actuator	0 to 1	In the case that the absolute function is disabled for the simplified absolute unit, set it to "0".

A SEP/P SEP/D SEP

No	Name	Initial Value	Setting Range	Remarks			
19	Absolute Battery Retention Time	2	0 to 3	Set the standard for the absolute data storage time.			
				Parameter No.19 Setting	Encoder Max. Rotation Speed [rpm]	Reference for Battery Retention Time (reference) [day]	
					When the connected actuator is a model other than RCA2-***N;	When the connected actuator is RCA2-***N;	
				0	100	75	20
				1	200	150	15
	2	400	300	10			
	3	800	600	5			
20	Position Data Change Password	0000	0000 to 9999	When "0000" is set, the password input is not required.			

(Note 1) Please refer to the next section if the servo-motor gain adjustment is required.

3.5 Servo Adjustment

The parameters are preset at the factory before shipment to perform a stable operation in response to the position command in the range of the actuator use with the rated (maximum) transportable weight. However, the preset setting cannot always be the optimum load condition in the actual use. It is considered that the actuator needs to be operated under various conditions including resonance, vibration trigger, load fluctuation, etc.

It is clear that the servo performs a more stable operation with the optimum adjustment that best suits to the actual installation, load and operation conditions. Please note such a product like our actuator that is designed to enable the operation in a large number of situations may need a servo adjustment in a use under certain conditions.

3.5.1 Adjustment for ASEP and PSEP

(Note) Make an adjustment following Section 3.5.2 if using DSEP.

No.	Situation that Requires Adjustment	How to Adjust
1	Takes time to finish positioning/Positioning accuracy is not appropriate / Shorter takt time is desired	Increase the "Servo-Motor Gain Number". By setting a bigger number, the follow-up ability to the position command becomes better. Try to increase one by one. If the value is too large, an overshoot is caused easily and may cause noise or vibration. <u>If the "Servo-Motor Gain Number" is increased, also adjust the "Velocity Loop Proportional Gain" in increasing direction to ensure the stability in the control system.</u>
2	Vibration is generated at acceleration/ deceleration	Decrease the numbers for "Acceleration/Deceleration Setting" and "Servo-Motor Gain Number". The cause of the problem is the lack of strength in the mechanical structure. Reinforce the mechanical structure, first. If the "Servo-Motor Gain Number" setting is too low, it takes long time to finish the positioning.
3	Speed is uneven during the movement/ Speed accuracy is not appropriate	Increase the "Velocity Loop Proportional Gain" value. By setting a bigger number, the follow-up ability to the speed command becomes better. Setting the value too big makes the mechanical components easy to vibrate. As a reference for the setting, increase the value <u>little by little by 20% from the initial setting.</u>
4	Abnormal noise is generated/Especially, when stop and operation in low speed (less than 50mm/sec), comparatively high noise is generated.	Input the "Torque Filter Time Constant". Try to increase by 50 as a reference for the setting. If the setting is too large, it may cause a loss of control system stability and lead the generation of vibration. • Prior to Adjustment: This phenomenon is likely to occur when the stiffness of the mechanical components is not sufficient. The actuator itself may also resonate if its stroke is over 600mm or it is belt-driven type. Before having an adjustment, check if: 1) The settings for "Servo-Motor Gain Number", "Velocity Loop Proportional Gain" and "Velocity Loop Integrated Gain" values are extreme. 2) The stiffness of the load is sufficient as much as possible, or the attachments are not loosened. 3) The actuator unit is properly mounted with no looseness. 4) There is no waviness on the actuator mounting surface.

3.5.2 Adjustment for DSEP

No.	Situation that Requires Adjustment	How to Adjust																																																												
1	Hunching occurs during the positioning stop	Set the parameters following the procedure below and check the operation.																																																												
2	Speed is uneven during the movement / Speed accuracy is not appropriate	Finish the adjustment once the operation is improved. There is no need to proceed to the next step.																																																												
		<p>Step 1 : Change "Velocity Loop Integrated Gain" Set the 5 types of values below in the following order and check the operation.</p> <table border="1" data-bbox="619 768 1120 1010"> <thead> <tr> <th>Setting Order</th> <th>Velocity Loop Integrated Gain Settings</th> </tr> </thead> <tbody> <tr><td>1</td><td>411</td></tr> <tr><td>2</td><td>592</td></tr> <tr><td>3</td><td>925</td></tr> <tr><td>4</td><td>1645</td></tr> <tr><td>5</td><td>3700</td></tr> </tbody> </table> <p>If no improvement in operation is confirmed, proceed to Step 2. Step 2 : Change "Velocity Loop Proportional Gain" and "Velocity Loop Integrated Gain" Set the 6 types of values below in the following order and check the operation.</p> <table border="1" data-bbox="619 1182 1249 1532"> <thead> <tr> <th colspan="3">● If load is 0.2kg or lower;</th> </tr> <tr> <th>Setting Order</th> <th>Velocity Loop Integrated Gain Settings</th> <th>Velocity Loop Integrated Gain Settings</th> </tr> </thead> <tbody> <tr><td>1</td><td>42</td><td>382</td></tr> <tr><td>2</td><td>42</td><td>520</td></tr> <tr><td>3</td><td>42</td><td>749</td></tr> <tr><td>4</td><td>42</td><td>1171</td></tr> <tr><td>5</td><td>42</td><td>2081</td></tr> <tr><td>6</td><td>42</td><td>4683</td></tr> </tbody> </table> <table border="1" data-bbox="619 1574 1249 1924"> <thead> <tr> <th colspan="3">● If load is above 0.2kg;</th> </tr> <tr> <th>Setting Order</th> <th>Velocity Loop Integrated Gain Settings</th> <th>Velocity Loop Integrated Gain Settings</th> </tr> </thead> <tbody> <tr><td>1</td><td>32</td><td>231</td></tr> <tr><td>2</td><td>32</td><td>315</td></tr> <tr><td>3</td><td>32</td><td>453</td></tr> <tr><td>4</td><td>32</td><td>708</td></tr> <tr><td>5</td><td>32</td><td>1259</td></tr> <tr><td>6</td><td>32</td><td>2833</td></tr> </tbody> </table> <p>If no improvement in operation is confirmed, please contact IAI.</p>	Setting Order	Velocity Loop Integrated Gain Settings	1	411	2	592	3	925	4	1645	5	3700	● If load is 0.2kg or lower;			Setting Order	Velocity Loop Integrated Gain Settings	Velocity Loop Integrated Gain Settings	1	42	382	2	42	520	3	42	749	4	42	1171	5	42	2081	6	42	4683	● If load is above 0.2kg;			Setting Order	Velocity Loop Integrated Gain Settings	Velocity Loop Integrated Gain Settings	1	32	231	2	32	315	3	32	453	4	32	708	5	32	1259	6	32	2833
Setting Order	Velocity Loop Integrated Gain Settings																																																													
1	411																																																													
2	592																																																													
3	925																																																													
4	1645																																																													
5	3700																																																													
● If load is 0.2kg or lower;																																																														
Setting Order	Velocity Loop Integrated Gain Settings	Velocity Loop Integrated Gain Settings																																																												
1	42	382																																																												
2	42	520																																																												
3	42	749																																																												
4	42	1171																																																												
5	42	2081																																																												
6	42	4683																																																												
● If load is above 0.2kg;																																																														
Setting Order	Velocity Loop Integrated Gain Settings	Velocity Loop Integrated Gain Settings																																																												
1	32	231																																																												
2	32	315																																																												
3	32	453																																																												
4	32	708																																																												
5	32	1259																																																												
6	32	2833																																																												

A SEP/P SEP/D SEP

No.	Situation that Requires Adjustment	How to Adjust
3	Abnormal noise is generated/Especially, when stop and operation in low speed (less than 20mm/sec), comparatively high noise is generated.	Change "Velocity Loop Proportional Gain" and "Velocity Loop Integrated Gain" to the following values and check the operation. Speed Loop Proportional Gain : 32 Velocity Loop Integrated Gain : 231

3.5.3 Servo Parameter

- **User Parameter No. 3 Servo-Motor Gain Number**

This parameter decides the responsibility to the position control loop.

When the set value is increased, the follow-up ability to the position command becomes better.

However, if the value is too large, an overshoot is caused easily. When the set value is too low, the follow-up ability to the position command is degraded and it takes longer time to complete the positioning.

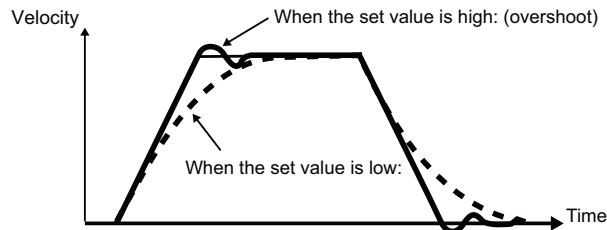

- **User Parameter No. 4 Torque Filter Time Constant**

This parameter decides the filter time constant for the torque command. In the case that the machine's resonance frequency is the same as or lower than the servo-motor loop response frequency, the motor causes a vibration. When the set value is increased, this mechanical resonance can be controlled.

However, when this value is increased too much, the stability in the control system might be damaged.

- **User Parameter No. 5 Velocity Loop Proportional Gain**

This parameter decides the responsibility to the velocity control loop.

When the set value is increased, the follow-up ability to the velocity command becomes better (the servo-motor rigidity is enhanced).

As the load inertia is larger, increase the set value. However, if the set value is increased too much, an over-chute or oscillation is caused, which might easily cause a vibration in the mechanical system.

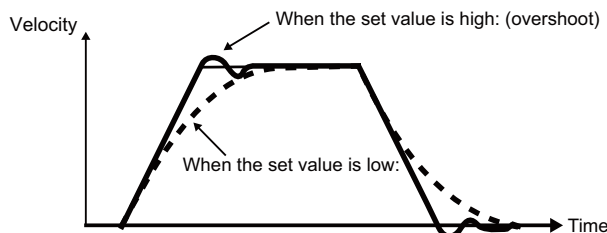

- **User Parameter No. 6 Velocity Loop Integrated Gain**

This parameter decides the responsibility to the velocity control loop.

Having a bigger setting value enables higher response ability to the speed command. Also, repulsion to the load fluctuation becomes higher.

If the setting value is too large, it may cause overshooting or generates vibration and makes the mechanical system easy to generate vibration.

When the set value is too low, the follow-up ability to the position command is degraded and it takes longer time to complete the positioning.

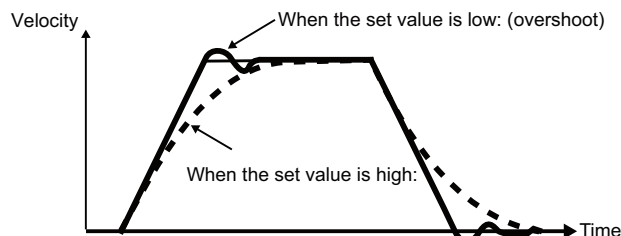

3.6 Alarm

3.6.1 Alarm Level

The alarms are classified to 2 types of levels by the content of the error.

Alarm Level	Status Lamp	Condition in Error Occurrence	Cancellation Method
Operation Cancellation	Red Light is turned ON.	Actuator compulsory stop (Motor power (servo) turns off after deceleration and stop.)	Perform a reset with the reset signal (RES) or by using a teaching tool such as PC software
Cold Start	Red Light is turned ON.	Actuator compulsory stop (Motor power (servo) turns off after deceleration and stop.Home-return completion status will be cancelled.)	Cut and supply the power again (Home-return operation is required again for Incremental Type.)

When cancelling the alarm, always find the cause and remove it before cancelling the alarm in any case.

If you have a difficulty in removing the cause of alarm or the alarm cannot be cancelled even after the cause is removed, please contact us.

Note

If the same error occurs again after the alarm is cancelled, it means the cause of the alarm is not removed. Try to remove the cause again, and redo the cancel process.

3.6.2 Alarm Codes and Trouble Shooting

Error Level	Code	Alarm Name	Cause/Treatment
Operation Cancellation	080	Movement Command in Servo-Motor OFF	Cause :The movement command is input while the servo-motor is turned OFF. Treatment :Input "SON" signal to turn ON the servo-motor.
	082	Movement Command in Incomplete Home Return	Cause :The movement command is input while the home return has not been completed. Treatment :Input ST0 signal to perform the home return operation.
	084	Movement Command during Home Return Operation	Cause :The movement command is input during the home return operation. Treatment :Input the command after confirming the home return completion (LS0 or PE0 is turned ON).
	085	Position Data Error in the Movement	Cause :The value corresponding to the specified position, is not set. Treatment :Set the effective value in the Position Setting operation.
Cold Start	0A1	Parameter Data Error	Cause :The data input range in the parameter domain is not correct. Treatment :Change the value to the correct one referring to the user parameter table.
Operation Cancellation	0A2	Position Data Error	Cause : (1) The movement command is issued while the target position has not set on the Position Data. (2) The target position value set on the Position Data exceeds the soft limit set value. Treatment : (1) Set the target position. (2) Change the target position value to the one within the soft limit set value.
	0A3	Position Command Data Error	Cause :The velocity value or acceleration value exceeds the maximum set value. Treatment :Change the value to the appropriate one.
	0A7	Command Deceleration Error	In the case that the velocity is changed (increased) close to the forward position or backward position and the acceleration/deceleration has been set lower, the actuator might exceed the soft limit. Cause :The command issue timing for velocity change during the movement, is too late. Treatment :Issue the command much earlier so that the actuator does not exceed the soft limit and an over-chute is not caused.
Cold Start	0A8	Motor · Encoder Type not Corresponding	Cause :The type of the motor or encoder set to the parameter is not corresponding to the system. Treatment :Redo the parameter settings.
	0B4	Electric Angling Mismatching	Cause :The position deviation counter is over-flown. Treatment :Confirm about the load conditions, that the work does not interfere with any object nearby or the (brake has been released, etc. Also, the counter overflow before the electric angle determination (in the Z-Phase Indetectable condition) can be considered. In such case, the motor cable broken or encoder wire output error is supposed, so check the cable connection.
Operation Cancellation	0B5	Z-Phase Position Error	The position where the Z-phase is detected before the home return operation, is out of the specified range. Cause :Encoder Error Treatment :Contact our company.
	0B6	Z-Phase Detection Time Out	For this controller, when the servo-motor is turned ON for the first time after the power is input, the magnetic pole phase detection (pole sensing) is performed. At that time, the encoder Z-phase signal is not detected after the specified time period. Cause : (1) A looseness in the connection section of the actuator connecting cable or wire breakage is considered. (2) In the case of the unit with the brake, the brake is not released. (3) The motor load might be too large due to the external force. (4) The sliding resistance in the actuator itself might be too large. Treatment : (1) and (2) Check for the actuator cable wiring condition. (3) Confirm that there is no error in the mechanical part assembly condition. (4) In the case that the load weight is normal, move the actuator by hand to check the sliding resistance after the power is turned OFF. In the case that there is any error in the actuator itself, contact our company.

Error Level	Code	Alarm Name	Cause/Treatment
Cold Start	0B7	Magnetic Pole Indeterminate	<p>For this controller, when the servo-motor is turned ON for the first time after the power is input, the magnetic pole phase detection (pole sensing) is performed. At that time, the magnetic pole phase is not detected after the specified time period.</p> <p>Cause : (1) A looseness in the connection section of the actuator connecting cable or wire breakage is considered. (2) In the case of the unit with the brake, the brake is not released. (3) The motor load might be too large due to the external force. (4) The sliding resistance in the actuator itself might be too large.</p> <p>Treatment : (1) and (2) Check for the actuator connecting cable wiring condition. (3) Confirm that there is no error in the mechanical part assembly condition. (4) In the case that the load weight is normal, move the actuator by hand to check the sliding resistance after the power is turned OFF. In the case that there is any error in the actuator itself, contact our company.</p>
	0B8	Excitement Detection Error	<p>For this controller, when the servo-motor is turned ON for the first time after the power is input, the magnetic pole phase detection (pole sensing) is performed. However, the specified encoder signal level is not detected after the excitement for the specified time period.</p> <p>Cause : (1) A looseness in the connection section of the actuator connecting cable or wire breakage is considered. (2) In the case of the unit with the brake, the brake is not released. (3) The motor load might be too large due to the external force. (4) The power is input while the actuator hits the mechanical end. (5) The sliding resistance in the actuator itself might be too large.</p> <p>Treatment : (1) and (2) Check for the motor connecting cable wiring condition. (3) Confirm that there is no error in the mechanical part assembly condition. (4) Move the actuator away from the mechanical end and re-input the power. (5) In the case that the load weight is normal, move the actuator by hand to check the sliding resistance after the power is turned OFF. In the case that there is any error in the actuator itself, contact our company.</p>
Operation Cancellation	0BA	Home Position Sensor Indetectable	<p>For the actuator for which the home return sensor is used, the home return operation has not been completed normally.</p> <p>Cause : (1) The work interferes with the surrounding object in the course of the actuator's home return operation. (2) The actuator's sliding resistance might be partly too high. (3) The home return check sensor installation error, breakdown or wire breakage is supposed.</p> <p>Treatment : In the case that the work does not interfere with anything, the cause (2) or (3) is supposed. In such case, contact our company.</p>
	0BE	Home Return Time Out	<p>Cause : Even when the specified time period has passed after the home return operation start, the home return operation is not completed (It never occurs in the normal operation).</p> <p>Treatment : It is considered that the combination of the controller and actuator is not correct. Contact our company.</p>
	0C0	Actual Speed Excessive	<p>Cause : The motor speed exceeds the maximum motor speed set using the maker's set parameters. (1) The actuator's sliding resistance might be partly too high. (2) The load is increased too much due to the momentary external force. It might be caused when the load is lightened before detecting the servo-motor error due to the above causes (1) and (2), and the actuator is moved suddenly.</p> <p>Treatment : Check that there is no error in the mechanical part assembly condition. In the case that there is any error in the actuator itself, contact our company.</p>

A SEP/P SEP/D SEP

Error Level	Code	Alarm Name	Cause/Treatment
Operation Cancellation	0C1	Servo-Motor Error	<p>The motor operation is not available for 2 seconds or more after the movement command is received and before the actuator reaches the target position.</p> <p>Cause : (1) A looseness in the connection section of the actuator connecting cable or wire breakage is considered. (2) In the case of the unit with the brake, the brake is not released. (3) The motor load might be too large due to the external force. (4) The sliding resistance in the actuator itself might be too large.</p> <p>Treatment : (1) and (2) Check for the actuator connecting cable wiring condition. (3) Confirm that there is no error in the mechanical part assembly condition. (4) In the case that the load weight is normal, move the actuator by hand to check the sliding resistance after the power is turned OFF. In the case that there is any error in the actuator itself, contact our company.</p>
Cold Start	0C8	Overcurrent	<p>Cause : The output current in the power circuit section is increased abnormally. The motor coil insulation degradation might be considered.</p> <p>Treatment : Measure the resistance between the motor connecting cable U, V and W and insulation resistance with earth cable and confirm whether or not there is insulation degradation. When the measurement is performed, consult with our company.</p>
Operation Cancellation	0C9	Overvoltage	<p>An over-voltage is caused in the 24V input power (24V + 20%: 28.8V or more).</p> <p>Cause : (1) The source voltage in the 24V power unit is too high. (2) A breakdown of the part inside the controller is considered.</p> <p>Treatment : Check for the input source voltage. In the case that the voltage is normal, contact our company.</p>
Cold Start	0CA	Overheat	<p>Cause : (1) The temperature inside the controller is too high. (95°C or more) (2) When the actuator is vertically installed, in the case that the deceleration setting is too high when it is moved downward, the regenerative resistance energy might be insufficient. (3) The defective part inside the controller is considered.</p> <p>Treatment : (1) Lower the ambient temperature around the controller. (2) Review the setting conditions so that the deceleration curve becomes linear. In the case that the cause is not applicable to (1) or (2), contact our company.</p>
	0CB	Current Sensor Offset Adjustment Error	<p>An error is found in the current detection sensor in the initialization in the start-up operation.</p> <p>Cause : (1) A breakdown of the current detection sensor or peripheral component is supposed. (2) An error in the offset adjustment is supposed.</p> <p>Treatment : A work (PC board) change or offset adjustment is required. Contact our company.</p>
Operation Cancellation	0CC	Control Power Source Voltage Error	<p>An over-voltage is caused in the 24V input power (24V + 20%: 28.8V or more).</p> <p>Cause : (1) The source voltage in the 24V power unit is too high. (2) A breakdown of the part inside the controller is considered.</p> <p>Treatment : Check for the input source voltage. In the case that the voltage is normal, contact our company.</p>
	0CE	Control Power Source Voltage Drop	<p>The source voltage from the 24V power unit is decreased (24V - 20%: 19.2V or less).</p> <p>Cause : (1) The source voltage from the 24V power unit is too low. (2) A breakdown of the part inside the controller is considered.</p> <p>Treatment : Check for the input source voltage. In the case that the voltage is normal, contact our company.</p>
	0D2	Motor Power Source Voltage Excessive	<p>An over-voltage is caused in the motor power source (24V + 20%: 38V or more).</p> <p>Cause : (1) The source voltage in the 24V power unit is too high. (2) A breakdown of the part inside the controller is considered.</p> <p>Treatment : Check for the input source voltage. In the case that the voltage is normal, contact our company.</p>
	0D8	Deflection Overflow	<p>The position deviation counter is over flown.</p> <p>Cause : The velocity might be lowered in the movement operation due to an external force.</p> <p>Treatment : Confirm about the load conditions, that the work does not interfere with any object nearby or the brake has been released, etc., and if any, remove the cause.</p>

Error Level	Code	Alarm Name	Cause/Treatment
Operation Cancellation	0D9	Software Stroke Limit-Over Error	<p>Cause : (1) In the case that the actuator is vertically installed and the target position is close to the soft limit, because the load is too high, or the deceleration setting is too high, an over-chute might occur and the actuator might exceed the soft limit. (2) The actuator is moved out of the soft limit range when the servo-motor is turned OFF, and then the servo-motor turning ON operation is performed.</p> <p>Treatment : (1) Set the deceleration curve so that an over-chute is not caused when the actuator is stopped. (2) Return the actuator within the soft limit range and perform the servo-motor turning ON operation.</p>
	0DC	Pressing Motion Range Over Error	This alarm is generated when the reaction force after the pressing operation complete is too high and the actuator is pushed back to the start point of pressing operation. Revise the construction of the whole system.
Cold Start	0E0	Overload	<p>Cause : (1) The load is increased too much due to a external force. (2) In the case of the unit with the brake, the brake is not released. (3) The actuator's sliding resistance might be partly too large.</p> <p>Treatment : (1) In the case that an abnormal external force is impressed, remove it. (2) Check that the brake is released when the servo-motor is turned ON. If not, a breakdown of the brake, cable breakage, or defective part inside the controller, etc., is considered. (3) In the case that the work can be moved by hand, move it. Then, check that there is no location where a sliding resistant is too large.</p> <p>Note : Restart the operation after making sure to remove the cause. Also, in the case that the power is turned OFF, turn ON the power again after 30 minutes or to prevent motor coil burning.</p>
	0E5	Encoder Signal Receipt Error	<p>Cause : The missing connector inside the controller is considered.</p> <p>Treatment : In the case that the same error is caused after the power to the controller is re-input, contact our company.</p>
	0E7	A, B or Z-phase Wire Breakage	<p>The encoder signal is not detected normally.</p> <p>Cause : A looseness or wire breakage in the connector section of the actuator connecting cable is considered.</p> <p>Treatment : Check for the connection condition of the actuator connecting cable and perform the continuity test. If normal, contact our company.</p>
	0E8	A or B-phase Wire Breakage	<p>The encoder signal is not detected normally.</p> <p>Cause : A looseness or wire breakage in the connector section of the actuator connecting cable is considered.</p>
	0E9	A -phase Wire Breakage	<p>Treatment : Check for the connection condition of the actuator connecting cable and perform the continuity test. If normal, contact our company.</p>
	0EA	B-phase Wire Breakage	
	0EC	PS-phase Wire Breakage	<p>Cause : A looseness or wire breakage in the connector section of the actuator connecting cable is considered.</p> <p>Treatment : Check for the connection condition of the actuator connecting cable and perform the continuity test. If normal, contact our company.</p>
Operation Cancellation	0ED	Absolute Encoder Error Detection 1	<p>Cause : (1) When the absolute unit reset is completed and the power is re-input, the current position might be changed due to an external force. (2) When the absolute unit is reset, the current position might be changed due to an external force.</p> <p>Treatment : (1) Turn OFF the power and arrange so that a vibration is not added to the actuator and turn ON the power again. (2) Arrange so that a vibration is not added to the actuator and perform the home return operation again.</p>
	0EE	Absolute Encoder Error Detection 2	<p>Cause : (1) It might be caused in the simplified absolute type when the power is turned ON for the first time after the battery is connected. (2) The battery voltage is too much decreased to keep the encoder counter operation. (3) The encoder cable is disconnected during the power failure, or a wire breakage occurs in the encoder cable. (4) The parameter is changed.</p> <p>Treatment : In the case of (1), (2) or (4), perform the Absolute Reset operation according to the procedure. (2) Supply the power for 72 hours or more to charge the battery sufficiently and then perform the Absolute Reset operation.</p>

A SEP/P SEP/D SEP

Error Level	Code	Alarm Name	Cause/Treatment
Operation Cancellation	0EF	Absolute Encoder Error Detection 3	<p>Cause :The current value is increased to the velocity value more than specified in the motor speed setting due to an external force, etc., while the power is turned OFF.</p> <p>Treatment :Take the measure so that the actuator is not moved at the speed more than the set value while the power is turned OFF. In the case that there is still enough time before the battery shutoff, increase the set value for the parameter No.19. After any error occurs, perform the Absolute Reset operation.</p>
Cold Start	0F0	Driver Logic Error	<p>Cause :An overload, parameter (Motor Type) setting not correct, or noise controller breakdown, etc., is supposed.</p> <p>Treatment :Contact our company.</p>
	0F4	PC Board Mismatching Error	<p>In this controller, because of the motor capacity, the divided placement is performed on a single PC board. This error might be caused when it is found in the check before the startup that the motor type does not appropriate for the PC board.</p> <p>Cause :A parameter setting error or PC board setup error is considered.</p> <p>Treatment :When this error occurs, contact our company.</p>
Operation Cancellation	0F5	Non-Volatile Memory Write Verification Error	<p>When the data is written on the non-volatile memory (EEPROM), the original data is compared to the written data to confirm whether it is the same or not. This error is caused when the data is not the same.</p> <p>Cause :(1) A breakdown of the non-volatile memory is considered. (2) The reload times might exceed 100,000. (The standard nominal reload times for non-volatile memory is 100,000).</p> <p>Treatment :When the error is caused even when the power is re-input, contact our company.</p>
	0F6	Non-Volatile Memory Write Time Out	<p>This shows that no response is received within the specified time period when the data is written on the non-volatile memory.</p> <p>Cause :(1) A breakdown of the non-volatile memory is considered. (2) The reload times exceed 100,000. (The standard nominal reload times for non-volatile memory is 100,000).</p> <p>Treatment :When the error is caused even when the power is re-input, contact our company.</p>
Cold Start	0F8	Non-Volatile Memory Data Breakdown	<p>A data error is detected in the non-volatile memory check in the startup operation.</p> <p>Cause :(1) A breakdown of the non-volatile memory (2) The reload times exceed 100,000. (The standard nominal reload times for non-volatile memory is 100,000).</p> <p>Treatment :When the error is caused even when the power is re-input, contact our company.</p>
	0FA	CPU Error	<p>The CPU operation is not normal.</p> <p>Cause :(1) A breakdown of the CPU itself is supposed. (2) An operation error due to a noise is supposed.</p> <p>Treatment :When the error is caused even when the power is re-input, contact our company.</p>
	0FC	Logic Error	<p>Inside the controller does not function normally.</p> <p>Cause :A part breakdown inside the controller or operation error due to a noise is considered.</p> <p>Treatment :When the error is caused even when the power is re-input, contact our company.</p>

4. Appendix

4.1 List of Specifications of Connectable Actuators

The specifications included in this specification list are limited to those needed to set operating conditions and parameters. For other detailed specifications, refer to the catalog or operation manual for your actuator.

⚠ Note:

- The push force is based on the rated push speed (factory setting) indicated in the list, and provides only a guideline.
- Make sure the actual push force is equal to or greater than the minimum push force. If not, the push force will not stabilize.
- Do not change the setting of push speed (parameter No. 7). If you must change the push speed, consult IAI.
- If, among the operating conditions, the positioning speed is set to a value equal to or smaller than the push speed, the push speed will become the set speed and the specified push force will not generate.

[1] PSEP

Actuator series	Type	Feed screw	No. of encoder pulses	Lead [mm]	Mounting direction	Minimum speed [mm/s]	Maximum speed [mm/s]	Maximum acceleration/ deceleration [G]	Minimum push force [N]	Maximum push force [N]	Rated push speed [mm/s]
RCP2 (rod type)	RA2C	Ball screw	800	1	Horizontal/ vertical	1.25	25	0.05	50	100	3
	RA3C	Ball screw	800	5	Horizontal/ vertical	6.25	187	0.2	21	73.5	20
				2.5	Horizontal/ vertical	3.12	114		50	156.8	
	RGD3C	Ball screw	800	5	Horizontal/ vertical	6.25	187	0.2	21	73.5	20
				2.5	Horizontal vertical	3.12	114 93		50	156.8	
	RA4C	Ball screw	800	10	Horizontal/ vertical	12.5	458 (at to 250st) 350 (at 300st)	0.2	30	150	20
				5	Horizontal/ vertical	6.25	250 (at 50 to 200st) 237 (at 250st) 175 (at 300st)		75	284	
				2.5	Horizontal Vertical	3.12	125 (at 50 to 200st) 118 (at 250st) 87 (at 300st) 114		150	358	
	RGS4C	Ball screw	800	10	Horizontal/ vertical	12.5	458 (at to 250st) 350 (at 300st)	0.2	30	150	20
				5	Horizontal/ vertical	6.25	250 (at 50 to 200st) 237 (at 250st) 175 (at 300st)		75	284	
				2.5	Horizontal Vertical	3.12	125 (at 50 to 200st) 118 (at 250st) 87 (at 300st) 114		150	358	
	RGD4C	Ball screw	800	10	Horizontal/ vertical	12.5	458 (at to 250st) 350 (at 300st)	0.2	30	150	20
				5	Horizontal/ vertical	6.25	250 (at 50 to 200st) 237 (at 250st) 175 (at 300st)		75	284	
				2.5	Horizontal Vertical	3.12	125 (at 50 to 200st) 118 (at 250st) 87 (at 300st) 114		150	358	

A SEP/P SEP/D SEP

Actuator series	Type	Feed screw	No. of encoder pulses	Lead [mm]	Mounting direction	Minimum speed [mm/s]	Maximum speed [mm/s]	Maximum acceleration/ deceleration [G]	Minimum push force [N]	Maximum push force [N]	Rated push speed [mm/s]
RCP2 (rod type)	RA6C	Ball screw	800	16	Horizontal	20	450	0.2	75	240	20
					Vertical		400				
				8	Horizontal/vertical	10	210				
	4	Horizontal/vertical	5	130							
	RGS6C	Ball screw	800	16	Horizontal	20	450	0.2	75	240	20
					Vertical		400				
				8	Horizontal/vertical	10	210				
	4	Horizontal/vertical	5	130							
	RGD6C	Ball screw	800	16	Horizontal	20	450	0.2	75	240	20
					Vertical		400				
				8	Horizontal/vertical	10	210				
	4	Horizontal/vertical	5	130							
SRA4R	Ball screw	800	5	Horizontal/vertical	6.25	250	0.3	26	90	20	
			2.5	Horizontal	3.12	124	0.2	50	170		
	Vertical	125									
RCP2 (slider type)	SRGS4R	Ball screw	800	5	Horizontal/vertical	6.25	250	0.3	26	90	20
				2.5	Horizontal	3.12	124	0.2	50	170	
		Vertical	125								
	SRGD4R	Ball screw	800	5	Horizontal/vertical	6.25	250	0.3	26	90	20
2.5				Horizontal	3.12	124	0.2	50	170		
	Vertical	125									

A SEP/P SEP/D SEP

Actuator series	Type	Feed screw	No. of encoder pulses	Lead [mm]	Mounting direction	Minimum speed [mm/s]	Maximum speed [mm/s]	Maximum acceleration/ deceleration [G]	Minimum push force [N]	Maximum push force [N]	Rated push speed [mm/s]
RCP2 (slider type)	SA5C	Ball screw	800	20	Horizontal	25	380 (at 50st) 540 (at 100st) 660 (at 150st) 770 (at 200st) 860 (at 250st) 940 (at 300st) 1000 (at 350 to 550st) 980 (at 600st) 850 (at 650st) 740 (at 700st) 650 (at 750st) 580 (at 800st)	0.7	11	39	20
					Vertical		380 (at 50st) 540 (at 100st) 660 (at 150st) 770 (at 200st) 800 (at 250 to 600st) 740 (at 700st) 650 (at 750st) 580(at 800st)	0.2			
				12	Horizontal	15	300 (at 50st) 460 (at 100st) 600 (at 150 to 550st) 540 (at 600st) 460 (at 650st) 400 (at 700st) 360 (at 750st) 300 (at 800st)	0.7	40	115	
					Vertical		295 (at 50st) 300 (at 100 to 550st) 270 (at 600st) 230 (at 650st) 200 (at 700st) 180 (at 750st) 150 (at 800st)	0.3			
				6	Horizontal	7.5	150 (at to 550st) 135 (at 600st) 115 (at 650st) 100 (at 700st) 90 (at 750st) 75 (at 800st)	0.7	70	210	
					Vertical		300 (at 50st) 460 (at 100st) 600 (at 150 to 550st) 540 (at 600st) 460 (at 650st) 400 (at 700st) 360 (at 750st) 300 (at 800st)	0.3			
	3	Horizontal	3.75	295 (at 50st) 300 (at 100 to 550st) 270 (at 600st) 230 (at 650st) 200 (at 700st) 180 (at 750st) 150 (at 800st)	0.7	140	330				
		Vertical		150 (at to 550st) 135 (at 600st) 115 (at 650st) 100 (at 700st) 90 (at 750st) 75 (at 800st)	0.3						
	SA5R	Ball screw	800	12	Horizontal	15	300 (at 50st) 460 (at 100st) 600 (at 150 to 550st) 540 (at 600st) 460 (at 650st) 400 (at 700st) 360 (at 750st) 300 (at 800st)	0.3	-	-	-
					Vertical		295 (at 50st) 300 (at 100 to 550st) 270 (at 600st) 230 (at 650st) 200 (at 700st) 180 (at 750st) 150 (at 800st)	0.2			
				6	Horizontal	7.5	150 (at to 550st) 135 (at 600st) 115 (at 650st) 100 (at 700st) 90 (at 750st) 75 (at 800st)	0.3	-	-	
					Vertical		300 (at 50st) 460 (at 100st) 600 (at 150 to 550st) 540 (at 600st) 460 (at 650st) 400 (at 700st) 360 (at 750st) 300 (at 800st)	0.2			
3				Horizontal	3.75	295 (at 50st) 300 (at 100 to 550st) 270 (at 600st) 230 (at 650st) 200 (at 700st) 180 (at 750st) 150 (at 800st)	0.2	-	-		
				Vertical		150 (at to 550st) 135 (at 600st) 115 (at 650st) 100 (at 700st) 90 (at 750st) 75 (at 800st)	0.2				



A SEP / P SEP / D SEP

Actuator series	Type	Feed screw	No. of encoder pulses	Lead [mm]	Mounting direction	Minimum speed [mm/s]	Maximum speed [mm/s]	Maximum acceleration/ deceleration [G]	Minimum push force [N]	Maximum push force [N]	Rated push speed [mm/s]
RCP2 (slider type)	SA6C	Ball screw	800	20	Horizontal	25	380 (at 50st) 540 (at 100st) 660 (at 150st) 770 (at 200st) 860 (at 250st) 940 (at 300st) 1000 (at 350 to 550st) 980 (at 600st) 850 (at 650st) 740 (at 700st) 650 (at 750st) 580 (at 800st)	0.7	11	39	20
					Vertical		380 (at 50st) 540 (at 100st) 660 (at 150st) 770 (at 200st) 800 (at 250 to 600st) 740 (at 700st) 650 (at 750st) 580 (at 800st)				
				12	Horizontal	15	300 (at 50st) 460 (at 100st) 600 (at 150 to 550st) 540 (at 600st) 460 (at 650st) 400 (at 700st) 360 (at 750st) 300 (at 800st)	0.7	40	115	
					Vertical		295 (at 50st) 300 (at 100 to 550st) 270 (at 600st) 230 (at 650st) 200 (at 700st) 180 (at 750st) 150 (at 800st)	0.3			
				6	Horizontal	7.5	150 (at to 550st) 135 (at 600st) 115 (at 650st) 100 (at 700st) 90 (at 750st) 75 (at 800st)	0.7	70	210	
					Vertical		150 (at to 550st) 135 (at 600st) 115 (at 650st) 100 (at 700st) 90 (at 750st) 75 (at 800st)	0.3			
	3	Horizontal	3.75	300 (at 50st) 460 (at 100st) 600 (at 150 to 550st) 540 (at 600st) 460 (at 650st) 400 (at 700st) 360 (at 750st) 300 (at 800st)	0.7	140	330				
		Vertical		295 (at 50st) 300 (at 100 to 550st) 270 (at 600st) 230 (at 650st) 200 (at 700st) 180 (at 750st) 150 (at 800st)	0.3						
	SA6R	Ball screw	800	12	Horizontal	15	300 (at 50st) 460 (at 100st) 600 (at 150 to 550st) 540 (at 600st) 460 (at 650st) 400 (at 700st) 360 (at 750st) 300 (at 800st)	0.3	-	-	-
					Vertical		295 (at 50st) 300 (at 100 to 550st) 270 (at 600st) 230 (at 650st) 200 (at 700st) 180 (at 750st) 150 (at 800st)	0.2			
				6	Horizontal	7.5	150 (at to 550st) 135 (at 600st) 115 (at 650st) 100 (at 700st) 90 (at 750st) 75 (at 800st)	0.3	-	-	
					Vertical		150 (at to 550st) 135 (at 600st) 115 (at 650st) 100 (at 700st) 90 (at 750st) 75 (at 800st)	0.2			
3				Horizontal	3.75	300 (at 50st) 460 (at 100st) 600 (at 150 to 550st) 540 (at 600st) 460 (at 650st) 400 (at 700st) 360 (at 750st) 300 (at 800st)	0.2	-	-		
				Vertical		295 (at 50st) 300 (at 100 to 550st) 270 (at 600st) 230 (at 650st) 200 (at 700st) 180 (at 750st) 150 (at 800st)	0.2				

A SEP / P SEP / D SEP

Actuator series	Type	Feed screw	No. of encoder pulses	Lead [mm]	Mounting direction	Minimum speed [mm/s]	Maximum speed [mm/s]	Maximum acceleration/ deceleration [G]	Minimum push force [N]	Maximum push force [N]	Rated push speed [mm/s]
RCP2 (slider type)	SA7C	Ball screw	800	16	Horizontal	20	380 (at 50st) 470 (at 100st) 533 (at 150 to 750st) 480 (at 800st)	0.3	90	250	20
					Vertical			0.2			
				8	Horizontal	10	266 (at 50 to 700st) 240 (at 800st)	0.3	150	500	
					Vertical			0.2			
				4	Horizontal	5	133 (at 50 to 700st) 120 (at 800st)	0.2	280	800	
					Vertical			0.2			
	SA7R	Ball screw	800	16	Horizontal	20	380 (at 50st) 470 (at 100st) 533 (at 150 to 750st) 480 (at 800st)	0.3	-	-	-
					Vertical			400			
				8	Horizontal	10	266 (at 50 to 700st) 240 (at 800st)	0.3	-	-	
					Vertical			0.2			
				4	Horizontal	5	133 (at 50 to 700st) 120 (at 800st)	0.2	-	-	
					Vertical			0.2			
	SS7C	Ball screw	800	12	Horizontal	15	600 (at 50 to 500st) 470 (at 600st)	0.3	40	120	20
					Vertical			0.2			
				6	Horizontal	7.5	300 (at 50 to 500st) 230 (at 600st)	0.3	75	220	
					Vertical			0.2			
				3	Horizontal	3.75	150 (at 50 to 500st) 115 (at 600st)	0.2	140	350	
					Vertical			0.2			
	SS7R	Ball screw	800	12	Horizontal	15	600 (at 50 to 500st) 470 (at 600st)	0.3	-	-	-
					Vertical			440 (at 50 to 500st) 440 (at 600st)			
				6	Horizontal	7.5	250 (at 50 to 500st) 230 (at 600st)	0.3	-	-	
					Vertical			0.2			
				3	Horizontal	3.75	105 (at 50 to 500st) 105 (at 600st)	0.2	-	-	
					Vertical			0.2			
SS8C	Ball screw	800	20	Horizontal	25	666 (at 50 to 800st) 625 (at to 900st) 515 (at to 1000st)	0.3	50	180	20	
				Vertical			600 (at 50 to 800st) 600 (at to 900st) 515 (at to 1000st)				0.2
			10	Horizontal	12.5	333 (at 50 to 800st) 310 (at to 900st) 255 (at to 1000st)	0.3	95	320		
				Vertical			300 (at 50 to 800st) 300 (at to 900st) 255 (at to 1000st)				0.2
			5	Horizontal	6.25	165 (at 50 to 800st) 155 (at to 900st) 125 (at to 1000st)	0.2	180	630		
				Vertical			150 (at 50 to 800st) 150 (at to 900st) 125 (at to 1000st)				0.2

A SEP / P SEP / D SEP

Actuator series	Type	Feed screw	No. of encoder pulses	Lead [mm]	Mounting direction	Minimum speed [mm/s]	Maximum speed [mm/s]	Maximum acceleration/ deceleration [G]	Minimum push force [N]	Maximum push force [N]	Rated push speed [mm/s]	
RCP2 (slider type)	SS8R	Ball screw	800	20	Horizontal	25	600 (at 50 to 800st) 600 (at to 900st) 515 (at to 1000st)	0.3	-	-	-	
					Vertical		333 (at 50 to 800st) 333 (at to 900st) 333 (at to 1000st)					
				10	Horizontal	12.5	300 (at 50 to 800st) 300 (at to 900st) 255 (at to 1000st)	0.3				
					Vertical		250 (at 50 to 800st) 250 (at to 900st) 250 (at to 1000st)					
				5	Horizontal	6.25	160 (at 50 to 800st) 155 (at to 900st) 125 (at to 1000st)	0.2				
					Vertical		140 (at 50 to 800st) 140 (at to 900st) 140 (at to 1000st)					
	HS8C	Ball screw	800	30	Horizontal	37.5	1200 (at 50 to 800st) 1000 (at to 900st) 800 (at to 1000st)	0.3				
					Vertical		750 (at 50 to 800st) 750 (at to 900st) 750 (at to 1000st)					
	RCP2 (belt type)	BA6/BA6U	Belt	800	Equivalent to 54	Horizontal	67.5	1000	0.5	-	-	-
		BA7/BA7U	Belt	800	Equivalent to 54	Horizontal	67.5	1500	0.5	-	-	-
RCP2 (gripper type)	GRSS	-	800	1.57	-	1.96	78	-	4	14	20	
	GRLS	-	800	12	-	15 (deg/s)	600 (deg/s)	-	1.8	6.4	5 (deg/s)	
	GRS	-	800	1	-	1.25	33.3	-	9	21	5	
	GRM	-	800	1.1	-	1.37	36.7	-	23	80	5	
	GRST	-	800	1.05	-	1.31	34	-	15	40	5	
		-	800	2.27	-	2.83	75	-	7.5	20	5	
	GR3LS	-	800	12	-	15	200	-	5	18	5 (deg/s)	
	GR3LM	-	800	12	-	15	200	-	15	51	5 (deg/s)	
	GR3SS	-	800	2.5	-	3.12	40	-	7	22	5	
	GR3SM	-	800	3	-	3.75	50	-	30	102	5	
	GRHM	-	800	2	-	2.5	100	-	25	125	5	
GRHB	-	800	2	-	2.5	100	-	60	200	5		

A SEP/P SEP/D SEP

Actuator series	Type	Feed screw	No. of encoder pulses	Lead [mm]	Mounting direction	Minimum speed [mm/s]	Maximum speed [mm/s]	Maximum acceleration/ deceleration [G]	Minimum push force [N]	Maximum push force [N]	Rated push speed [mm/s]
RCP2 (rotary type)	RTBS	-	800	Gear ratio: 1/30	-	15 (deg/s)	400 (deg/s)	-	-	-	-
		-		Gear ratio: 1/45	-	10 (deg/s)	266 (deg/s)	-	-	-	-
	RTBSL	-	800	Gear ratio: 1/30	-	15 (deg/s)	400 (deg/s)	-	-	-	-
		-		Gear ratio: 1/45	-	10 (deg/s)	266 (deg/s)	-	-	-	-
	RTCS	-	800	Gear ratio: 1/30	-	15 (deg/s)	400 (deg/s)	-	-	-	-
		-		Gear ratio: 1/45	-	10 (deg/s)	266 (deg/s)	-	-	-	-
	RTCSL	-	800	Gear ratio: 1/30	-	15 (deg/s)	400 (deg/s)	-	-	-	-
		-		Gear ratio: 1/45	-	10 (deg/s)	266 (deg/s)	-	-	-	-
	RTB	-	800	Gear ratio: 1/20	-	22.5 (deg/s)	600 (deg/s)	-	-	-	-
		-		Gear ratio: 1/30	-	15 (deg/s)	400 (deg/s)	-	-	-	-
	RTBL	-	800	Gear ratio: 1/20	-	22.5 (deg/s)	600 (deg/s)	-	-	-	-
		-		Gear ratio: 1/30	-	15 (deg/s)	400 (deg/s)	-	-	-	-
	RTC	-	800	Gear ratio: 1/20	-	22.5 (deg/s)	600 (deg/s)	-	-	-	-
		-		Gear ratio: 1/30	-	15 (deg/s)	400 (deg/s)	-	-	-	-
	RTCL	-	800	Gear ratio: 1/20	-	22.5 (deg/s)	600 (deg/s)	-	-	-	-
		-		Gear ratio: 1/30	-	15 (deg/s)	400 (deg/s)	-	-	-	-
	RTBB	-	800	Gear ratio: 1/20	-	22.5 (deg/s)	600 (deg/s)	-	-	-	-
		-		Gear ratio: 1/30	-	15 (deg/s)	400 (deg/s)	-	-	-	-
	RTBBL	-	800	Gear ratio: 1/20	-	22.5 (deg/s)	600 (deg/s)	-	-	-	-
		-		Gear ratio: 1/30	-	15 (deg/s)	400 (deg/s)	-	-	-	-
RTCB	-	800	Gear ratio: 1/20	-	22.5 (deg/s)	600 (deg/s)	-	-	-	-	
	-		Gear ratio: 1/30	-	15 (deg/s)	400 (deg/s)	-	-	-	-	
RTCBL	-	800	Gear ratio: 1/20	-	22.5 (deg/s)	600 (deg/s)	-	-	-	-	
	-		Gear ratio: 1/30	-	15 (deg/s)	400 (deg/s)	-	-	-	-	

A SEP/P SEP/D SEP

Actuator series	Type	Feed screw	No. of encoder pulses	Lead [mm]	Mounting direction	Minimum speed [mm/s]	Maximum speed [mm/s]	Maximum acceleration/ deceleration [G]	Minimum push force [N]	Maximum push force [N]	Rated push speed [mm/s]	
RCP3 (rod type)	RA2AC	Lead screw	800	4	Horizontal/vertical	5	180 (at 25st) 200 (at 50 to 100st)	0.2	0.9	16.1	5	
				2		2.5	100		1.9	28.3		
				1		1.25	50		3.8	39.5		
	RA2BC	Lead screw	800	6	Horizontal/vertical	7.5	180 (at 25st) 280 (at 50st) 300 (at 75 to 150st)	0.2	0.6	11.9	5	
				4		5	180 (at 25st) 200 (at 50 to 150st)		0.9	16.1		
				2		2.5	100		1.9	28.3		
	RA2AR	Lead screw	800	4	Horizontal/vertical	5	180 (at 25st) 200 (at 50 to 150st)	0.2	0.9	16.1	5	
				2		2.5	100		1.9	28.3		
				1		1.25	50		3.8	39.5		
	RA2BR	Lead screw	800	6	Horizontal/vertical	7.5	180 (at 25st) 280 (at 50st) 300 (at 75 to 150st)	0.2	0.6	11.9	5	
				4		5	180 (at 25st) 200 (at 50 to 150st)		0.9	16.1		
				2		2.5	100		1.9	28.3		
RCP3 (slider type)	SA2AC	Lead screw	800	4	Horizontal	5	180 (at 25st) 200 (at 50 to 100st)	0.2	-	-	-	
				2		2.5	100		-	-	-	
				1		1.25	50		-	-	-	
	SA2BC	Lead screw	800	6	Horizontal	7.5	180 (at 25st) 280 (at 50st) 300 (at 75 to 150st)	0.2	-	-	-	
				4		5	180 (at 25st) 200 (at 50 to 150st)		-	-	-	
				2		2.5	100		-	-	-	
	SA2AR	Lead screw	800	4	Horizontal	5	180 (at 25st) 200 (at 50 to 100st)	0.2	-	-	-	
				2		2.5	100		-	-	-	
				1		1.25	50		-	-	-	
	SA2BR	Lead screw	800	6	Horizontal	7.5	180 (at 25st) 280 (at 50st) 300 (at 75 to 150st)	0.2	-	-	-	
				4		5	180 (at 25st) 200 (at 50 to 150st)		-	-	-	
				2		2.5	100		-	-	-	
	SA3C	Ball screw	800	6	Horizontal	7.5	300	0.2	0.3	9	15	20
					Vertical				0.2			
				4	Horizontal	5	200		0.3	14	22	
					Vertical				0.2			
				2	Horizontal	2.5	100		0.2	27	44	
					Vertical				0.2			
SA3R	Ball screw	800	6	Horizontal	7.5	300	0.2	0.3	9	15	-	
				Vertical				0.2				
			4	Horizontal	5	200		0.3	14	22		
				Vertical				0.2				
			2	Horizontal	2.5	100		0.2	27	44		
				Vertical				0.2				

A SEP / P SEP / D SEP

Actuator series	Type	Feed screw	No. of encoder pulses	Lead [mm]	Mounting direction	Minimum speed [mm/s]	Maximum speed [mm/s]	Maximum acceleration/ deceleration [G]	Minimum push force [N]	Maximum push force [N]	Rated push speed [mm/s]					
RCP3 (slider type)	SA4C	Ball screw	800	10	Horizontal	12.5	380 (at 50st) 500 (at 100 to 500st)	0.7	20	34	20					
					Vertical			0.3								
				5	Horizontal	6.25	250	0.7	40	68						
					Vertical			0.3								
				2.5	Horizontal	3.12	125	0.7	82	136						
					Vertical			0.3								
	SA4R	Ball screw	800	10	Horizontal	12.5	380 (at 50st) 500 (at 100 to 500st)	0.3	20	34	-					
					Vertical			0.2								
				5	Horizontal	6.25	250	0.3	40	68						
					Vertical			0.2								
				2.5	Horizontal	3.12	125	0.2	82	136						
					Vertical			0.2								
	SA5C	Ball screw	800	20	Horizontal	25	380 (at 50st) 540 (at 100st) 660 (at 150st) 770 (at 200st) 860 (at 250st) 940 (at 300st) 1000 (at 350 to 600st) 910 (at 650st) 790 (at 700st) 690 (at 750st) 610 (at 800st)	0.7	17	28	20					
												Vertical	0.2			
					12			Horizontal						15	380 (at 50st) 540 (at 100st) 600 (at 150 to 550st) 570 (at 600st) 490 (at 650st) 425 (at 700st) 370 (at 750st) 330 (at 800st)	0.7
												Vertical	0.3			
				6	Horizontal	7.5	300 (at 50 to 550st) 285 (at 600st) 245 (at 650st) 210 (at 700st) 185 (at 750st) 165 (at 800st)	0.7	57	95						
								Vertical				0.3				
3				Horizontal	3.75	150 (at 50 to 550st) 140 (at 600st) 120 (at 650st) 105 (at 700st) 90 (at 750st) 80 (at 800st)	0.7	113	189							
							Vertical			0.3						

A SEP/P SEP/D SEP

Actuator series	Type	Feed screw	No. of encoder pulses	Lead [mm]	Mounting direction	Minimum speed [mm/s]	Maximum speed [mm/s]	Maximum acceleration/ deceleration [G]	Minimum push force [N]	Maximum push force [N]	Rated push speed [mm/s]
RCP3 (slider type)	SA5R	Ball screw	800	12	Horizontal	15	380 (at 50st) 540 (at 100st) 600 (at 150 to 550st) 570 (at 600st) 490 (at 650st) 425 (at 700st) 370 (at 750st) 330 (at 800st)	0.3	30	47	20
					Vertical			0.2			
				6	Horizontal	7.5	300 (at 50 to 550st) 285 (at 600st) 245 (at 650st) 210 (at 700st) 185 (at 750st) 165 (at 800st)	0.3	58	95	
					Vertical			0.2			
				3	Horizontal	3.75	150 (at 50 to 550st) 140 (at 600st) 120 (at 650st) 105 (at 700st) 90 (at 750st) 80 (at 800st)	0.2	112	189	
					Vertical			0.2			
	SA6C	Ball screw	800	20	Horizontal	25	380 (at 50st) 540 (at 100st) 660 (at 150st) 770 (at 200st) 860 (at 250st) 940 (at 300st) 1000 (at 350 to 600st) 910 (at 650st) 790 (at 700st) 690 (at 750st) 610 (at 800st)	0.7	17	28	
					Vertical			0.2			
				12	Horizontal	15	380 (at 50st) 540 (at 100st) 600 (at 150 to 550st) 570 (at 600st) 490 (at 650st) 425 (at 700st) 370 (at 750st) 330 (at 800st)	0.7	28	47	
					Vertical			0.3			
				6	Horizontal	7.5	300 (at 50 to 550st) 285 (at 600st) 245 (at 650st) 210 (at 700st) 185 (at 750st) 165 (at 800st)	0.7	57	95	
					Vertical			0.3			
3	Horizontal	3.75	150 (at 50 to 550st) 140 (at 600st) 120 (at 650st) 105 (at 700st) 90 (at 750st) 80 (at 800st)	0.7	113	189					
	Vertical			0.3							

A SEP / P SEP / D SEP

Actuator series	Type	Feed screw	No. of encoder pulses	Lead [mm]	Mounting direction	Minimum speed [mm/s]	Maximum speed [mm/s]	Maximum acceleration/ deceleration [G]	Minimum push force [N]	Maximum push force [N]	Rated push speed [mm/s]					
RCP3 (slider type)	SA6R	Ball screw	800	12	Horizontal	15	380 (at 50st) 540 (at 100st) 600 (at 150 to 550st) 570 (at 600st) 490 (at 650st) 425 (at 700st) 370 (at 750st) 330 (at 800st)	0.3	30	47	20					
					Vertical			0.2								
				6	Horizontal	7.5	300 (at 50 to 550st) 285 (at 600st) 245 (at 650st) 210 (at 700st) 185 (at 750st) 165 (at 800st)	0.3	58	95						
					Vertical			0.2								
				3	Horizontal	3.75	150 (at 50 to 550st) 140 (at 600st) 120 (at 650st) 105 (at 700st) 90 (at 750st) 80 (at 800st)	0.2	112	189						
					Vertical			0.2								
				RCP3 (table type)	TA3C	Ball screw	800	6	Horizontal	7.5		300	0.3	5.4	9	20
									Vertical				0.2			
								4	Horizontal	5		200	0.3	8.4	14	
Vertical	0.2															
2	Horizontal	2.5	100					0.2	16.8	28						
	Vertical							0.2								
TA3R	Ball screw	800	6		Horizontal	7.5	300	0.3	5.4	9	20					
					Vertical			0.2								
			4		Horizontal	5	200	0.3	8.4	14						
					Vertical			0.2								
			2		Horizontal	2.5	100	0.2	16.8	28						
					Vertical			0.2								
TA4C	Ball screw	800	6		Horizontal	7.5	300	0.3	9	15	20					
					Vertical			0.2								
			4		Horizontal	5	200	0.3	13.2	22						
					Vertical			0.2								
			2		Horizontal	2.5	100	0.2	26.4	44						
					Vertical			0.2								
TA4R	Ball screw	800	6		Horizontal	7.5	300	0.3	9	15	20					
					Vertical			0.2								
			4		Horizontal	5	200	0.3	13.2	22						
					Vertical			0.2								
			2		Horizontal	2.5	100	0.2	26.4	44						
					Vertical			0.2								
TA5C	Ball screw	800	10	Horizontal	12.5	465	0.3	20	34	20						
				Vertical			0.2									
			5	Horizontal	6.25	250	0.3	40	68							
				Vertical			0.2									
			2.5	Horizontal	3.12	125	0.2	82	136							
				Vertical			0.2									
TA5R	Ball screw	800	10	Horizontal	12.5	465	0.3	20	34	20						
				Vertical			0.2									
			5	Horizontal	6.25	250	0.3	40	68							
				Vertical			0.2									
			2.5	Horizontal	3.12	125	0.2	82	136							
				Vertical			0.2									

A SEP/P SEP/D SEP

Actuator series	Type	Feed screw	No. of encoder pulses	Lead [mm]	Mounting direction	Minimum speed [mm/s]	Maximum speed		Maximum acceleration/ deceleration [G]	Minimum push force [N]	Maximum push force [N]	Rated push speed [mm/s]
							[mm/s]	[mm/s]				
RCP3 (table type)	TA6C	Ball screw	800	12	Horizontal	15	560	0.3	30	47	20	
					Vertical		500	0.2				
				6	Horizontal	7.5	300	0.3	58	95		
					Vertical			0.2				
				3	Horizontal	3.75	150	0.2	112	189		
					Vertical			0.2				
	TA6R	Ball screw	800	12	Horizontal	15	560	0.3	30	47		
					Vertical		500	0.2				
				6	Horizontal	7.5	300	0.3	58	95		
					Vertical			0.2				
				3	Horizontal	3.75	150	0.2	112	189		
					Vertical			0.2				
	TA7C	Ball screw	800	12	Horizontal	15	600	0.3	30	47		
					Vertical		580	0.2				
				6	Horizontal	7.5	300	0.3	58	95		
					Vertical			0.2				
				3	Horizontal	3.75	150	0.2	112	189		
					Vertical			0.2				
	TA7R	Ball screw	800	12	Horizontal	15	600	0.3	30	47		
					Vertical		580	0.2				
				6	Horizontal	7.5	300	0.3	58	95		
					Vertical			0.2				
				3	Horizontal	3.75	150	0.2	112	189		
					Vertical			0.2				

A SEP/P SEP/D SEP

[2] ASEP

Actuator series	Type	Feed screw	Motor output [W]	No. of encoder pulses	Lead [mm]	Mounting direction	Minimum speed [mm/s]	Maximum speed [mm/s]	Maximum acceleration/ deceleration [G]	Minimum push force [N]	Maximum push force [N]	Rated push speed [mm/s]
RCA (rod type)	RA3C	Ball screw	20	800	10	Horizontal/vertical	12.5	500	Energy-saving spec.: 0.3 High acc/dec spec.: 1.0	-	-	-
					5	Horizontal/vertical	6.25	250	Energy-saving spec.: 0.3 High acc/dec spec.: 1.0	-	-	-
					2.5	Horizontal/vertical	3.12	125	Energy-saving spec.: 0.2 High acc/dec spec.: 0.2	-	-	-
					10	Horizontal/vertical	12.5	500	Energy-saving spec.: 0.3 High acc/dec spec.: 1.0	-	-	-
					5	Horizontal/vertical	6.25	250	Energy-saving spec.: 0.3 High acc/dec spec.: 1.0	-	-	-
					2.5	Horizontal/vertical	3.12	125	Energy-saving spec.: 0.2 High acc/dec spec.: 0.2	-	-	-
	RGS3C	Ball screw	20	800	10	Horizontal/vertical	12.5	500	Energy-saving spec.: 0.3 High acc/dec spec.: 1.0	-	-	-
					5	Horizontal/vertical	6.25	250	Energy-saving spec.: 0.3 High acc/dec spec.: 1.0	-	-	-
					2.5	Horizontal/vertical	3.12	125	Energy-saving spec.: 0.2 High acc/dec spec.: 0.2	-	-	-
					10	Horizontal/vertical	12.5	500	Energy-saving spec.: 0.3 High acc/dec spec.: 1.0	-	-	-
					5	Horizontal/vertical	6.25	250	Energy-saving spec.: 0.3 High acc/dec spec.: 1.0	-	-	-
					2.5	Horizontal/vertical	3.12	125	Energy-saving spec.: 0.2 High acc/dec spec.: 0.2	-	-	-
	RGD3C	Ball screw	20	800	10	Horizontal/vertical	12.5	500	Energy-saving spec.: 0.3 High acc/dec spec.: 1.0	-	-	-
					5	Horizontal/vertical	6.25	250	Energy-saving spec.: 0.3 High acc/dec spec.: 1.0	-	-	-
					2.5	Horizontal/vertical	3.12	125	Energy-saving spec.: 0.2 High acc/dec spec.: 0.2	-	-	-
					10	Horizontal/vertical	12.5	500	0.3	-	-	-
					5	Horizontal/vertical	6.25	250	0.3	-	-	-
					2.5	Horizontal/vertical	3.12	125	0.2	-	-	-
	RA3D	Ball screw	20	800	10	Horizontal/vertical	12.5	500	0.3	-	-	-
					5	Horizontal/vertical	6.25	250	0.3	-	-	-
					2.5	Horizontal/vertical	3.12	125	0.2	-	-	-
					10	Horizontal/vertical	12.5	500	0.3	-	-	-
					5	Horizontal/vertical	6.25	250	0.3	-	-	-
					2.5	Horizontal/vertical	3.12	125	0.2	-	-	-
RGS3D	Ball screw	20	800	10	Horizontal/vertical	12.5	500	0.3	-	-	-	
				5	Horizontal/vertical	6.25	250	0.3	-	-	-	
				2.5	Horizontal/vertical	3.12	125	0.2	-	-	-	
				10	Horizontal/vertical	12.5	500	0.3	-	-	-	
				5	Horizontal/vertical	6.25	250	0.3	-	-	-	
				2.5	Horizontal/vertical	3.12	125	0.2	-	-	-	
RGD3D	Ball screw	20	800	10	Horizontal/vertical	12.5	500	0.3	-	-	-	
				5	Horizontal/vertical	6.25	250	0.3	-	-	-	
				2.5	Horizontal/vertical	3.12	125	0.2	-	-	-	
				10	Horizontal/vertical	12.5	500	0.3	-	-	-	
				5	Horizontal/vertical	6.25	250	0.3	-	-	-	
				2.5	Horizontal/vertical	3.12	125	0.2	-	-	-	
RA3R	Ball screw	20	800	10	Horizontal/vertical	12.5	500	0.3	-	-	-	
				5	Horizontal/vertical	6.25	250	0.3	-	-	-	
				2.5	Horizontal/vertical	3.12	125	0.2	-	-	-	
				10	Horizontal/vertical	12.5	500	0.3	-	-	-	
				5	Horizontal/vertical	6.25	250	0.3	-	-	-	
				2.5	Horizontal/vertical	3.12	125	0.2	-	-	-	
RGD3R	Ball screw	20	800	10	Horizontal/vertical	12.5	500	0.3	-	-	-	
				5	Horizontal/vertical	6.25	250	0.3	-	-	-	
				2.5	Horizontal/vertical	3.12	125	0.2	-	-	-	
				10	Horizontal/vertical	12.5	500	0.3	-	-	-	
				5	Horizontal/vertical	6.25	250	0.3	-	-	-	
				2.5	Horizontal/vertical	3.12	125	0.2	-	-	-	

A SEP/P SEP/D SEP

Actuator series	Type	Feed screw	Motor output [W]	No. of encoder pulses	Lead [mm]	Mounting direction	Minimum speed [mm/s]	Maximum speed [mm/s]	Maximum acceleration/ deceleration [G]	Minimum push force [N]	Maximum push force [N]	Rated push speed [mm/s]
RCA (rod type)	RA4C	Ball screw	20	800	12	Horizontal/vertical	15	600	Energy-saving spec.: 0.3 High acc/dec spec.:1.0	-	-	-
					6	Horizontal/vertical	7.5	300	Energy-saving spec.: 0.3 High acc/dec spec.:1.0	-	-	-
					3	Horizontal/vertical	3.75	150	Energy-saving spec.: 0.2 High acc/dec spec.:0.2	-	-	-
			30		12	Horizontal/vertical	15	600	Energy-saving spec.: 0.3 High acc/dec spec.:1.0	-	-	-
					6	Horizontal/vertical	7.5	300	Energy-saving spec.: 0.3 High acc/dec spec.:1.0	-	-	-
					3	Horizontal/vertical	3.75	150	Energy-saving spec.: 0.2 High acc/dec spec.:0.2	-	-	-
	RGS4C	Ball screw	20	800	12	Horizontal/vertical	15	600	Energy-saving spec.: 0.3 High acc/dec spec.:1.0	-	-	-
					6	Horizontal/vertical	7.5	300	Energy-saving spec.: 0.3 High acc/dec spec.:1.0	-	-	-
					3	Horizontal/vertical	3.75	150	Energy-saving spec.: 0.2 High acc/dec spec.:0.2	-	-	-
			30		12	Horizontal/vertical	15	600	Energy-saving spec.: 0.3 High acc/dec spec.:1.0	-	-	-
					6	Horizontal/vertical	7.5	300	Energy-saving spec.: 0.3 High acc/dec spec.:1.0	-	-	-
					3	Horizontal/vertical	3.75	150	Energy-saving spec.: 0.2 High acc/dec spec.:0.2	-	-	-
	RGD4C	Ball screw	20	800	12	Horizontal/vertical	15	600	Energy-saving spec.: 0.3 High acc/dec spec.:1.0	-	-	-
					6	Horizontal/vertical	7.5	300	Energy-saving spec.: 0.3 High acc/dec spec.:1.0	-	-	-
					3	Horizontal/vertical	3.75	150	Energy-saving spec.: 0.2 High acc/dec spec.:0.2	-	-	-
			30		12	Horizontal/vertical	15	600	Energy-saving spec.: 0.3 High acc/dec spec.:1.0	-	-	-
					6	Horizontal/vertical	7.5	300	Energy-saving spec.: 0.3 High acc/dec spec.:1.0	-	-	-
					3	Horizontal/vertical	3.75	150	Energy-saving spec.: 0.2 High acc/dec spec.:0.2	-	-	-

A SEP/P SEP/D SEP

Actuator series	Type	Feed screw	Motor output [W]	No. of encoder pulses	Lead [mm]	Mounting direction	Minimum speed [mm/s]	Maximum speed [mm/s]	Maximum acceleration/ deceleration [G]	Minimum push force [N]	Maximum push force [N]	Rated push speed [mm/s]
RCA (rod type)	RA4D	Ball screw	20	800	12	Horizontal/vertical	15	600	0.3	-	-	-
					6	Horizontal/vertical	7.5	300	0.3	-	-	-
					3	Horizontal/vertical	3.75	150	0.2	-	-	-
			30		12	Horizontal/vertical	15	600	0.3	-	-	-
					6	Horizontal/vertical	7.5	300	0.3	-	-	-
					3	Horizontal/vertical	3.75	150	0.2	-	-	-
	RGS4D	Ball screw	20	800	12	Horizontal/vertical	15	600	0.3	-	-	-
					6	Horizontal/vertical	7.5	300	0.3	-	-	-
					3	Horizontal/vertical	3.75	150	0.2	-	-	-
			30		12	Horizontal/vertical	15	600	0.3	-	-	-
					6	Horizontal/vertical	7.5	300	0.3	-	-	-
					3	Horizontal/vertical	3.75	150	0.2	-	-	-
	RGD4D	Ball screw	20	800	12	Horizontal/vertical	15	600	0.3	-	-	-
					6	Horizontal/vertical	7.5	300	0.3	-	-	-
					3	Horizontal/vertical	3.75	150	0.2	-	-	-
			30		12	Horizontal/vertical	15	600	0.3	-	-	-
					6	Horizontal/vertical	7.5	300	0.3	-	-	-
					3	Horizontal/vertical	3.75	150	0.2	-	-	-
	RA4R	Ball screw	20	800	12	Horizontal/vertical	15	600	0.3	-	-	-
					6	Horizontal/vertical	7.5	300	0.3	-	-	-
					3	Horizontal/vertical	3.75	150	0.2	-	-	-
			30		12	Horizontal/vertical	15	600	0.3	-	-	-
					6	Horizontal/vertical	7.5	300	0.3	-	-	-
					3	Horizontal/vertical	3.75	150	0.2	-	-	-
RGD4R	Ball screw	20	800	12	Horizontal/vertical	15	600	0.3	-	-	-	
				6	Horizontal/vertical	7.5	300	0.3	-	-	-	
				3	Horizontal/vertical	3.75	150	0.2	-	-	-	
		30		12	Horizontal/vertical	15	600	0.3	-	-	-	
				6	Horizontal/vertical	7.5	300	0.3	-	-	-	
				3	Horizontal/vertical	3.75	150	0.2	-	-	-	

A SEP/P SEP/D SEP

Actuator series	Type	Feed screw	Motor output [W]	No. of encoder pulses	Lead [mm]	Mounting direction	Minimum speed [mm/s]	Maximum speed [mm/s]	Maximum acceleration/ deceleration [G]	Minimum push force [N]	Maximum push force [N]	Rated push speed [mm/s]				
RCA (rod type)	SRA4R	Ball screw	20	800	5	Horizontal	6.25	250	0.3	-	-	-				
						Vertical			0.2	-	-	-				
					2.5	Horizontal	3.12	125	0.2	-	-	-				
						Vertical			0.2	-	-	-				
					SRGS4R	Ball screw	20	800	5	Horizontal	6.25	250	0.3	-	-	-
										Vertical			0.2	-	-	-
	2.5	Horizontal	3.12	125					0.2	-	-	-				
		Vertical							0.2	-	-	-				
	SRGD4R	Ball screw	20	800	5	Horizontal	6.25	250	0.3	-	-	-				
						Vertical			0.2	-	-	-				
					2.5	Horizontal	3.12	125	0.2	-	-	-				
						Vertical			0.2	-	-	-				
RCA (slider type)	SA4C	Ball screw	20	800	10	Horizontal/vertical	12.5	665	Energy-saving spec.: 0.3 High acc/dec spec.: 1.0	-	-	-				
						Vertical			0.2	-	-	-				
					5	Horizontal/vertical	6.25	330	Energy-saving spec.: 0.3 High acc/dec spec.: 1.0	-	-	-				
						Vertical			0.2	-	-	-				
					2.5	Horizontal/vertical	3.12	165	Energy-saving spec.: 0.2 High acc/dec spec.: 0.2	-	-	-				
						Vertical			0.2	-	-	-				
	SA4D	Ball screw	20	800	10	Horizontal/vertical	12.5	665	0.3	-	-	-				
						Vertical			0.3	-	-	-				
					5	Horizontal/vertical	6.25	330	0.3	-	-	-				
						Vertical			0.2	-	-	-				
					2.5	Horizontal/vertical	3.12	165	0.2	-	-	-				
						Vertical			0.2	-	-	-				
	SA4R	Ball screw	20	800	10	Horizontal/vertical	12.5	665	0.3	-	-	-				
						Vertical			0.3	-	-	-				
					5	Horizontal/vertical	6.25	330	0.3	-	-	-				
						Vertical			0.2	-	-	-				
					2.5	Horizontal/vertical	3.12	165	0.2	-	-	-				
						Vertical			0.2	-	-	-				
	SA5C	Ball screw	20	800	20	Horizontal	25	1300	Energy-saving spec.: 0.3 High acc/dec spec.: 0.8	-	-	-				
						Vertical		800	0.8	-	-	-				
					12	Horizontal/vertical	15	800 (at 50 to 450st) 760 (at 500st)	Energy-saving spec.: 0.3 High acc/dec spec.: 0.8	-	-	-				
						Vertical		0.8	-	-	-					
					6	Horizontal/vertical	7.5	400 (at 50 to 450st) 380 (at 500st)	Energy-saving spec.: 0.3 High acc/dec spec.: 0.8	-	-	-				
						Vertical		0.8	-	-	-					
3					Horizontal/vertical	3.75	200 (at 50 to 450st) 190 (at 500st)	Energy-saving spec.: 0.2 High acc/dec spec.: 0.2	-	-	-					
					Vertical		0.2	-	-	-						
SA5D	Ball screw	20	800	12	Horizontal/vertical	15	800 (at 50 to 450st) 760 (at 500st)	0.3	-	-	-					
					Vertical		0.3	-	-	-						
				6	Horizontal/vertical	7.5	400 (at 50 to 450st) 380 (at 500st)	0.3	-	-	-					
					Vertical		0.2	-	-	-						
				3	Horizontal/vertical	3.75	200 (at 50 to 450st) 190 (at 500st)	0.2	-	-	-					
					Vertical		0.2	-	-	-						
SA5R	Ball screw	20	800	12	Horizontal/vertical	15	800 (at 50 to 450st) 760 (at 500st)	0.3	-	-	-					
					Vertical		0.3	-	-	-						
				6	Horizontal/vertical	7.5	400 (at 50 to 450st) 380 (at 500st)	0.3	-	-	-					
					Vertical		0.2	-	-	-						
				3	Horizontal/vertical	3.75	200 (at 50 to 450st) 190 (at 500st)	0.2	-	-	-					
					Vertical		0.2	-	-	-						

A SEP/P SEP/D SEP

Actuator series	Type	Feed screw	Motor output [W]	No. of encoder pulses	Lead [mm]	Mounting direction	Minimum speed [mm/s]	Maximum speed [mm/s]	Maximum acceleration/ deceleration [G]	Minimum push force [N]	Maximum push force [N]	Rated push speed [mm/s]			
RCA (slider type)	SA6C	Ball screw	30	800	20	Horizontal	25	1300 (at 50 to 500st) 1160 (at 550st) 990 (at 600st)	Energy-saving spec.: 0.3	-	-	-			
						Vertical		800	High acc/dec spec.: 0.8						
					12	Horizontal/vertical	15	800 (at 50 to 450st) 760 (at 500st) 640 (at 550st) 540 (at 600st)	Energy-saving spec.: 0.3	-	-	-			
								High acc/dec spec.: 1.0							
					6	Horizontal/vertical	7.5	400 (at 50 to 450st) 380 (at 500st) 320 (at 550st) 270 (at 600st)	Energy-saving spec.: 0.3	-	-	-			
								High acc/dec spec.: 1.0							
	3	Horizontal/vertical	3.75	200 (at 50 to 450st) 190 (at 500st) 160 (at 550st) 135 (at 600st)	Energy-saving spec.: 0.2	-	-	-							
				High acc/dec spec.: 0.2											
	SA6D	Ball screw	30	800	12	Horizontal/vertical	15	800 (at 50 to 450st) 760 (at 500st) 640 (at 550st) 540 (at 600st)	0.3	-	-	-			
								6	Horizontal/vertical				7.5	400 (at 50 to 450st) 380 (at 500st) 320 (at 550st) 270 (at 600st)	0.3
														3	Horizontal/vertical
	SA6R	Ball screw	30	800	12	Horizontal/vertical	15	800 (at 50 to 450st) 760 (at 500st) 640 (at 550st) 540 (at 600st)	0.3	-	-	-			
								6	Horizontal/vertical				7.5	400 (at 50 to 450st) 380 (at 500st) 320 (at 550st) 270 (at 600st)	0.3
														3	Horizontal/vertical
	SS4D	Ball screw	20	800	10	Horizontal/vertical	12.5	665	0.3	-	-	-			
								5	Horizontal/vertical				6.25	330	0.3
														2.5	Horizontal/vertical
	SS5D	Ball screw	20	800	12	Horizontal/vertical	15	800 (at 50 to 450st) 760 (at 500st)	0.3	-	-	-			
6								Horizontal/vertical	7.5				400 (at 50 to 450st) 380 (at 500st)	0.3	
													3	Horizontal/vertical	3.25
RCA (slider type)	SS6D	Ball screw	30	800	12	Horizontal/vertical	15	800 (at 50 to 450st) 760 (at 500st) 640 (at 550st) 540 (at 600st)	0.3	-	-	-			
								6	Horizontal/vertical				7.5	400 (at 50 to 450st) 380 (at 500st) 320 (at 550st) 270 (at 600st)	0.3
														3	Horizontal/vertical

A SEP/P SEP/D SEP

Actuator series	Type	Feed screw	Motor output [W]	No. of encoder pulses	Lead [mm]	Mounting direction	Minimum speed	Maximum speed	Maximum acceleration/ deceleration [G]	Minimum push force [N]	Maximum push force [N]	Rated push speed [mm/s]
							[mm/s]	[mm/s]				
RCA (arm type)	A4R	Ball screw	20	800	10	Horizontal/vertical	12.5	330	0.2	-	-	-
					5		6.25	165	0.2	-	-	-
	A5R	Ball screw	20	800	12	Horizontal/vertical	15	400	0.2	-	-	-
					6		7.5	200	0.2	-	-	-
	A6R	Ball screw	30	800	12	Horizontal/vertical	15	400	0.2	-	-	-
					6		7.5	200	0.2	-	-	-
RCA2 (rod type)	RN3N	Lead screw	10	1048	4	Horizontal/vertical	3.81	200	0.2	-	-	-
					2		1.9	100				
					1		0.95	50				
	RP3N	Lead screw	10	1048	4	Horizontal/vertical	3.81	200	0.2	-	-	-
					2		1.9	100				
					1		0.95	50				
	GS3N	Lead screw	10	1048	4	Horizontal/vertical	3.81	200	0.2	-	-	-
					2		1.9	100				
					1		0.95	50				
	GD3N	Lead screw	10	1048	4	Horizontal/vertical	3.81	200	0.2	-	-	-
					2		1.9	100				
					1		0.95	50				
	SD3N	Lead screw	10	1048	4	Horizontal/vertical	3.81	200	0.2	-	-	-
					2		1.9	100				
					1		0.95	50				
	RN4N	Ball screw	20	1048	6	Horizontal	5.72	270	0.3	-	-	-
						Vertical			220	0.2	-	-
					4	Horizontal	3.81	200	0.3	-	-	-
						Vertical			0.2	-	-	-
					2	Horizontal	1.9	100	0.2	-	-	-
						Vertical			0.2	-	-	-
		Lead screw			6	Horizontal	5.72	220	0.2	-	-	-
						Vertical			0.2	-	-	-
					4	Horizontal	3.81	200	0.2	-	-	-
Vertical						0.2			-	-	-	
2					Horizontal	1.9	100	0.2	-	-	-	
					Vertical			0.2	-	-	-	

A SEP/P SEP/D SEP

Actuator series	Type	Feed screw	Motor output [W]	No. of encoder pulses	Lead [mm]	Mounting direction	Minimum speed [mm/s]	Maximum speed [mm/s]	Maximum acceleration/ deceleration [G]	Minimum push force [N]	Maximum push force [N]	Rated push speed [mm/s]
RCA2 (rod type)	RP4N	Ball screw	20	1048	6	Horizontal	5.72	270	0.3	-	-	-
						Vertical		220	0.2	-	-	-
					4	Horizontal	3.81	200	0.3	-	-	-
						Vertical			0.2	-	-	-
					2	Horizontal	1.9	100	0.2	-	-	-
						Vertical			0.2	-	-	-
		Lead screw			6	Horizontal	5.72	220	0.2	-	-	-
						Vertical			0.2	-	-	-
					4	Horizontal	3.81	200	0.2	-	-	-
						Vertical			0.2	-	-	-
					2	Horizontal	1.9	100	0.2	-	-	-
						Vertical			0.2	-	-	-
	GS4N	Ball screw	20	1048	6	Horizontal	5.72	270	0.3	-	-	-
						Vertical		220	0.2	-	-	-
					4	Horizontal	3.81	200	0.3	-	-	-
						Vertical			0.2	-	-	-
					2	Horizontal	1.9	100	0.2	-	-	-
						Vertical			0.2	-	-	-
		Lead screw			6	Horizontal	5.72	220	0.2	-	-	-
						Vertical			0.2	-	-	-
					4	Horizontal	3.81	200	0.2	-	-	-
						Vertical			0.2	-	-	-
					2	Horizontal	1.9	100	0.2	-	-	-
						Vertical			0.2	-	-	-
	GD4N	Ball screw	20	1048	6	Horizontal	5.72	270	0.3	-	-	-
						Vertical		220	0.2	-	-	-
					4	Horizontal	3.81	200	0.3	-	-	-
						Vertical			0.2	-	-	-
					2	Horizontal	1.9	100	0.2	-	-	-
						Vertical			0.2	-	-	-
		Lead screw			6	Horizontal	5.72	220	0.2	-	-	-
						Vertical			0.2	-	-	-
					4	Horizontal	3.81	200	0.2	-	-	-
						Vertical			0.2	-	-	-
					2	Horizontal	1.9	100	0.2	-	-	-
						Vertical			0.2	-	-	-
SD4N	Ball screw	20	1048	6	Horizontal	5.72	240 (at 25st)	0.3	-	-	-	
					Vertical		300 (at 50 to 75st)		0.2	-	-	-
				4	Horizontal	3.81	200	0.3	-	-	-	
					Vertical			0.2	-	-	-	
				2	Horizontal	1.9	100	0.2	-	-	-	
					Vertical			0.2	-	-	-	
	Lead screw			6	Horizontal	5.72	200 (at 25st)	0.2	-	-	-	
					Vertical				300 (at 50 to 75st)	0.2	-	-
				4	Horizontal	3.81	200	0.2	-	-	-	
					Vertical			0.2	-	-	-	
				2	Horizontal	1.9	100	0.2	-	-	-	
					Vertical			0.2	-	-	-	

A SEP/P SEP/D SEP

Actuator series	Type	Feed screw	Motor output [W]	No. of encoder pulses	Lead [mm]	Mounting direction	Minimum speed [mm/s]	Maximum speed [mm/s]	Maximum acceleration/ deceleration [G]	Minimum push force [N]	Maximum push force [N]	Rated push speed [mm/s]
RCA2 (slider type)	SA3C	Ball screw	10	800	6	Horizontal	7.5	300	0.3	-	-	-
						Vertical			0.2	-	-	-
					4	Horizontal	5	200	0.3	-	-	-
						Vertical			0.2	-	-	-
					2	Horizontal	2.5	100	0.2	-	-	-
						Vertical			0.2	-	-	-
	SA3R	Ball screw	10	800	6	Horizontal	7.5	300	0.3	-	-	-
						Vertical			0.2	-	-	-
					4	Horizontal	5	200	0.3	-	-	-
						Vertical			0.2	-	-	-
					2	Horizontal	2.5	100	0.2	-	-	-
						Vertical			0.2	-	-	-
	SA4C	Ball screw	20	800	10	Horizontal	12.5	380 (at 50st) 500 (at 100 to 500st)	0.3	-	-	-
						Vertical			0.2	-	-	-
					5	Horizontal	6.25	250	0.3	-	-	-
						Vertical			0.2	-	-	-
					2.5	Horizontal	3.12	125	0.2	-	-	-
						Vertical			0.2	-	-	-
	SA4R	Ball screw	20	800	10	Horizontal	12.5	380 (at 50st) 500 (at 100 to 500st)	0.3	-	-	-
						Vertical			0.2	-	-	-
					5	Horizontal	6.25	250	0.3	-	-	-
						Vertical			0.2	-	-	-
					2.5	Horizontal	3.12	125	0.2	-	-	-
						Vertical			0.2	-	-	-

A SEP/P SEP/D SEP

Actuator series	Type	Feed screw	Motor output [W]	No. of encoder pulses	Lead [mm]	Mounting direction	Minimum speed [mm/s]	Maximum speed [mm/s]	Maximum acceleration/ deceleration [G]	Minimum push force [N]	Maximum push force [N]	Rated push speed [mm/s]
RCA2 (slider type)	SA5C	Ball screw	20	800	20	Horizontal	25	380 (at 50st) 540 (at 100st) 660 (at 150st) 770 (at 200st) 860 (at 250st) 940 (at 300st) 1000 (at 350 to 600st) 910 (at 650st) 790 (at 700st) 690 (at 750st) 610 (at 800st)	0.3	-	-	-
						Vertical		380 (at 50st) 540 (at 100st) 660 (at 150st) 770 (at 200st) 800 (at 250 to 650st) 790 (at 700st) 690 (at 750st) 610 (at 800st)				
					12	Horizontal	15	380 (at 50st) 540 (at 100st) 600 (at 150 to 550st) 570 (at 600st) 490 (at 650st) 425 (at 700st) 370 (at 750st) 330 (at 800st)	0.3	-	-	-
						Vertical		380 (at 50st) 540 (at 100st) 600 (at 150 to 550st) 570 (at 600st) 490 (at 650st) 425 (at 700st) 370 (at 750st) 330 (at 800st)	0.2	-	-	-
					6	Horizontal	7.5	300 (at 50 to 550st) 285 (at 600st) 245 (at 650st) 210 (at 700st) 185 (at 750st) 165 (at 800st)	0.3	-	-	-
						Vertical		300 (at 50 to 550st) 285 (at 600st) 245 (at 650st) 210 (at 700st) 185 (at 750st) 165 (at 800st)	0.2	-	-	-
	3	Horizontal	3.75	150 (at 50 to 550st) 140 (at 600st) 120 (at 650st) 105 (at 700st) 90 (at 750st) 80 (at 800st)	0.2	-	-	-				
		Vertical		150 (at 50 to 550st) 140 (at 600st) 120 (at 650st) 105 (at 700st) 90 (at 750st) 80 (at 800st)	0.2	-	-	-				
	SA5R	Ball screw	20	800	12	Horizontal	15	380 (at 50st) 540 (at 100st) 600 (at 150 to 550st) 570 (at 600st) 490 (at 650st) 425 (at 700st) 370 (at 750st) 330 (at 800st)	0.3	-	-	-
						Vertical		380 (at 50st) 540 (at 100st) 600 (at 150 to 550st) 570 (at 600st) 490 (at 650st) 425 (at 700st) 370 (at 750st) 330 (at 800st)	0.2	-	-	-
					6	Horizontal	7.5	300 (at 50 to 550st) 285 (at 600st) 245 (at 650st) 210 (at 700st) 185 (at 750st) 165 (at 800st)	0.3	-	-	-
						Vertical		300 (at 50 to 550st) 285 (at 600st) 245 (at 650st) 210 (at 700st) 185 (at 750st) 165 (at 800st)	0.2	-	-	-
3					Horizontal	3.75	150 (at 50 to 550st) 140 (at 600st) 120 (at 650st) 105 (at 700st) 90 (at 750st) 80 (at 800st)	0.2	-	-	-	
					Vertical		150 (at 50 to 550st) 140 (at 600st) 120 (at 650st) 105 (at 700st) 90 (at 750st) 80 (at 800st)	0.2	-	-	-	

A SEP/P SEP/D SEP

Actuator series	Type	Feed screw	Motor output [W]	No. of encoder pulses	Lead [mm]	Mounting direction	Minimum speed [mm/s]	Maximum speed [mm/s]	Maximum acceleration/ deceleration [G]	Minimum push force [N]	Maximum push force [N]	Rated push speed [mm/s]
RCA2 (slider type)	SA6C	Ball screw	30	800	20	Horizontal	25	380 (at 50st) 540 (at 100st) 660 (at 150st) 770 (at 200st) 860 (at 250st) 940 (at 300st) 1000 (at 350 to 600st) 910 (at 650st) 790 (at 700st) 690 (at 750st) 610 (at 800st)	0.3	-	-	-
						Vertical		380 (at 50st) 540 (at 100st) 660 (at 150st) 770 (at 200st) 800 (at 250 to 650st) 790 (at 700st) 690 (at 750st) 610 (at 800st)				
					12	Horizontal	15	380 (at 50st) 540 (at 100st) 600 (at 150 to 550st) 570 (at 600st) 490 (at 650st) 425 (at 700st) 370 (at 750st) 330 (at 800st)	0.3	-	-	-
						Vertical		380 (at 50st) 540 (at 100st) 600 (at 150 to 550st) 570 (at 600st) 490 (at 650st) 425 (at 700st) 370 (at 750st) 330 (at 800st)	0.2	-	-	-
					6	Horizontal	7.5	300 (at 50 to 550st) 285 (at 600st) 245 (at 650st) 210 (at 700st) 185 (at 750st) 165 (at 800st)	0.3	-	-	-
						Vertical		300 (at 50 to 550st) 285 (at 600st) 245 (at 650st) 210 (at 700st) 185 (at 750st) 165 (at 800st)	0.2	-	-	-
	3	Horizontal	3.75	150 (at 50 to 550st) 140 (at 600st) 120 (at 650st) 105 (at 700st) 90 (at 750st) 80 (at 800st)	0.2	-	-	-				
		Vertical		150 (at 50 to 550st) 140 (at 600st) 120 (at 650st) 105 (at 700st) 90 (at 750st) 80 (at 800st)	0.2	-	-	-				
	SA6R	Ball screw	30	800	12	Horizontal	15	380 (at 50st) 540 (at 100st) 600 (at 150 to 550st) 570 (at 600st) 490 (at 650st) 425 (at 700st) 370 (at 750st) 330 (at 800st)	0.3	-	-	-
						Vertical		380 (at 50st) 540 (at 100st) 600 (at 150 to 550st) 570 (at 600st) 490 (at 650st) 425 (at 700st) 370 (at 750st) 330 (at 800st)	0.2	-	-	-
					6	Horizontal	7.5	300 (at 50 to 550st) 285 (at 600st) 245 (at 650st) 210 (at 700st) 185 (at 750st) 165 (at 800st)	0.3	-	-	-
						Vertical		300 (at 50 to 550st) 285 (at 600st) 245 (at 650st) 210 (at 700st) 185 (at 750st) 165 (at 800st)	0.2	-	-	-
3					Horizontal	3.75	150 (at 50 to 550st) 140 (at 600st) 120 (at 650st) 105 (at 700st) 90 (at 750st) 80 (at 800st)	0.2	-	-	-	
					Vertical		150 (at 50 to 550st) 140 (at 600st) 120 (at 650st) 105 (at 700st) 90 (at 750st) 80 (at 800st)	0.2	-	-	-	

A SEP/P SEP/D SEP

Actuator series	Type	Feed screw	Motor output [W]	No. of encoder pulses	Lead [mm]	Mounting direction	Minimum speed [mm/s]	Maximum speed [mm/s]	Maximum acceleration/ deceleration [G]	Minimum push force [N]	Maximum push force [N]	Rated push speed [mm/s]
RCA2 (table type)	TC3N	Lead screw	10	1048	4	Horizontal/vertical	3.81	200	0.2	-	-	-
					2		1.9	100				
					1		0.95	50				
	TW3N	Lead screw	10	1048	4	Horizontal/vertical	3.81	200	0.2	-	-	-
					2		1.9	100				
					1		0.95	50				
	TF3N	Lead screw	10	1048	4	Horizontal/vertical	3.81	200	0.2	-	-	-
					2		1.9	100				
					1		0.95	50				
	TC4N	Ball screw	20	1048	6	Horizontal/Vertical	5.72	270	0.3	-	-	-
					220			0.2	-	-	-	
					4	Horizontal/Vertical	3.81	200	0.3	-	-	-
					200			0.2	-	-	-	
					2	Horizontal/Vertical	1.9	100	0.2	-	-	-
					100			0.2	-	-	-	
		Lead screw	6	Horizontal/Vertical	5.72	220	0.2	-	-	-		
			220			0.2	-	-	-			
			4	Horizontal/Vertical	3.81	200	0.2	-	-	-		
			200			0.2	-	-	-			
			2	Horizontal/Vertical	1.9	100	0.2	-	-	-		
			100			0.2	-	-	-			
	TW4N	Ball screw	20	1048	6	Horizontal/Vertical	5.72	270	0.3	-	-	-
					220			0.2	-	-	-	
					4	Horizontal/Vertical	3.81	200	0.3	-	-	-
					200			0.2	-	-	-	
					2	Horizontal/Vertical	1.9	100	0.2	-	-	-
					100			0.2	-	-	-	
		Lead screw	6	Horizontal/Vertical	5.72	220	0.2	-	-	-		
			220			0.2	-	-	-			
			4	Horizontal/Vertical	3.81	200	0.2	-	-	-		
			200			0.2	-	-	-			
			2	Horizontal/Vertical	1.9	100	0.2	-	-	-		
			100			0.2	-	-	-			
	TF4N	Ball screw	20	1048	6	Horizontal/Vertical	5.72	270	0.3	-	-	-
					220			0.2	-	-	-	
					4	Horizontal/Vertical	3.81	200	0.3	-	-	-
200					0.2			-	-	-		
2					Horizontal/Vertical	1.9	100	0.2	-	-	-	
100							0.2	-	-	-		
Lead screw		6	Horizontal/Vertical	5.72	220	0.2	-	-	-			
		220			0.2	-	-	-				
		4	Horizontal/Vertical	3.81	200	0.2	-	-	-			
		200			0.2	-	-	-				
		2	Horizontal/Vertical	1.9	100	0.2	-	-	-			
		100			0.2	-	-	-				
TA4C	Ball screw	10	800	6	Horizontal/Vertical	7.5	300	0.3	-	-	-	
				300			0.2	-	-	-		
				4	Horizontal/Vertical	5	200	0.3	-	-	-	
				200			0.2	-	-	-		
				2	Horizontal/Vertical	2.5	100	0.2	-	-	-	
				100			0.2	-	-	-		

A SEP/P SEP/D SEP

Actuator series	Type	Feed screw	Motor output [W]	No. of encoder pulses	Lead [mm]	Mounting direction	Minimum speed [mm/s]	Maximum speed [mm/s]	Maximum acceleration/ deceleration [G]	Minimum push force [N]	Maximum push force [N]	Rated push speed [mm/s]
RCA2 (table type)	TA4R	Ball screw	10	800	6	Horizontal	7.5	300	0.3	-	-	-
						Vertical			0.2	-	-	-
					4	Horizontal	5	200	0.3	-	-	-
						Vertical			0.2	-	-	-
					2	Horizontal	2.5	100	0.2	-	-	-
						Vertical			0.2	-	-	-
	TA5C	Ball screw	20	800	10	Horizontal	12.5	465	0.3	-	-	-
						Vertical		400	0.2	-	-	-
					5	Horizontal	6.25	250	0.3	-	-	-
						Vertical			0.2	-	-	-
					2.5	Horizontal	3.12	125	0.2	-	-	-
						Vertical			0.2	-	-	-
	TA5R	Ball screw	20	800	10	Horizontal	12.5	465	0.3	-	-	-
						Vertical		400	0.2	-	-	-
					5	Horizontal	6.25	250	0.3	-	-	-
						Vertical			0.2	-	-	-
					2.5	Horizontal	3.12	125	0.2	-	-	-
						Vertical			0.2	-	-	-
	TA6C	Ball screw	20	800	12	Horizontal	15	560	0.3	-	-	-
						Vertical		500	0.2	-	-	-
					6	Horizontal	7.5	300	0.3	-	-	-
						Vertical			0.2	-	-	-
					3	Horizontal	3.75	150	0.2	-	-	-
						Vertical			0.2	-	-	-
TA6R	Ball screw	20	800	12	Horizontal	15	560	0.3	-	-	-	
					Vertical		500	0.2	-	-	-	
				6	Horizontal	7.5	300	0.3	-	-	-	
					Vertical			0.2	-	-	-	
				3	Horizontal	3.75	150	0.2	-	-	-	
					Vertical			0.2	-	-	-	
TA7C	Ball screw	30	800	12	Horizontal	15	600	0.3	-	-	-	
					Vertical		580	0.2	-	-	-	
				6	Horizontal	7.5	300	0.3	-	-	-	
					Vertical			0.2	-	-	-	
				3	Horizontal	3.75	150	0.2	-	-	-	
					Vertical			0.2	-	-	-	
TA7R	Ball screw	30	800	12	Horizontal	15	600	0.3	-	-	-	
					Vertical		580	0.2	-	-	-	
				6	Horizontal	7.5	300	0.3	-	-	-	
					Vertical			0.2	-	-	-	
				3	Horizontal	3.75	150	0.2	-	-	-	
					Vertical			0.2	-	-	-	
RCL	RA1L	Linear	-	715	-	Horizontal/vertical	42	300	2	0.75	2	2
	RA2L			855		Horizontal/vertical	42	340	2	1.5	4	4
	RA3L			1145		Horizontal/vertical	42	450	2	3	8	8
	SA1L			715		Horizontal	42	420	2	-	-	-
	SA2L			855		Horizontal	42	460	2	-	-	-
	SA3L			1145		Horizontal	42	600	2	-	-	-
	SA4L			715		Horizontal	42	1200	2	-	-	-
	SM4L			715		Horizontal	42	1200	2	-	-	-
	SA5L			855		Horizontal	42	1400	2	-	-	-
	SM5L			855		Horizontal	42	1400	2	-	-	-
	SA6L			1145		Horizontal	42	1600	2	-	-	-
SM6L	1145	Horizontal	42	1600	2	-	-	-				
RCD	RA1D	Lead screw	3	400	2	Horizontal	2.5	300	1	0.41	5.98	5

4.2 Pressing Force and Current Limit Value

RCP2 Series

Rod Type

RA2C Type

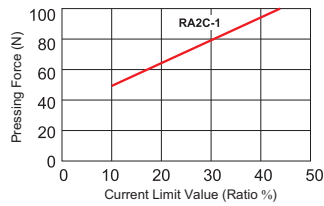

Note

- The correlation of the pressing force and the current limit value is the rated pressing speed (in the setting at the delivery) and is a reference value.
- Use the actuator with the setting above the minimum pressing force value. The pressing force will be unstable if it is below the minimum pressing force value.
- Do not change the pressing speed (Parameter No.7). Please contact and inform us if a change is necessary.
- If the positioning speed setting in the operation condition is made lower than the pressing speed, the pressing speed will follow that speed, thus cannot perform the expected pressing force.

RA3C/RGD3C

RA4C/RGS4C/RGD4C

RA6C/RGS6C/RGD6C

High Speed Type

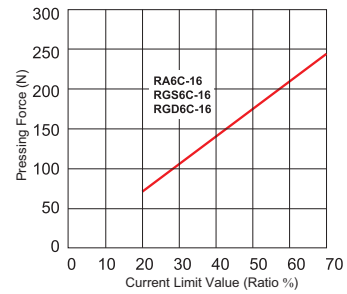
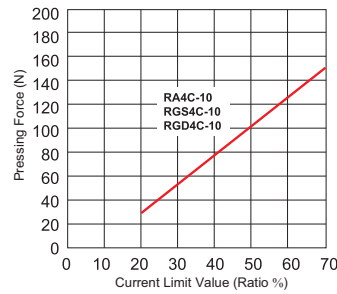

Medium Speed Type

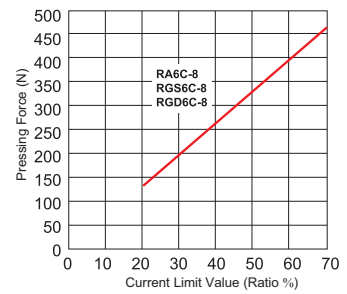
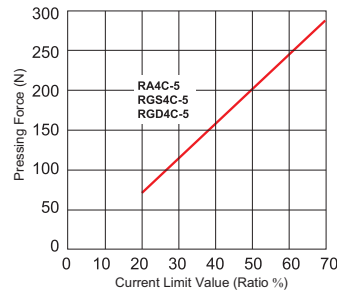
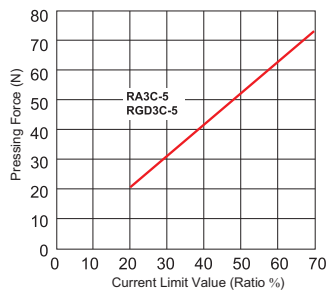

Low Speed Type

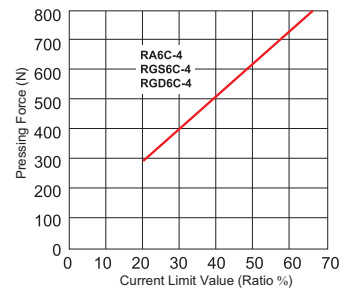
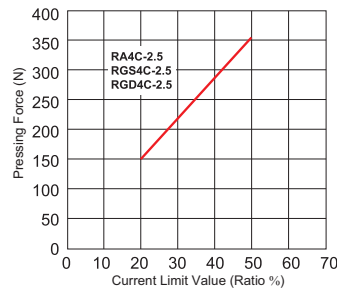
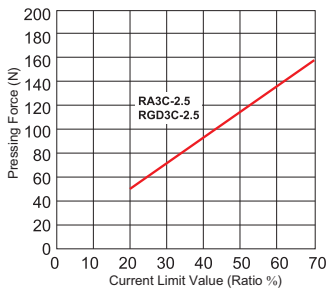

RCP2 Series

Short Length Type

SRA4R/SRGS4R/SRGD4R

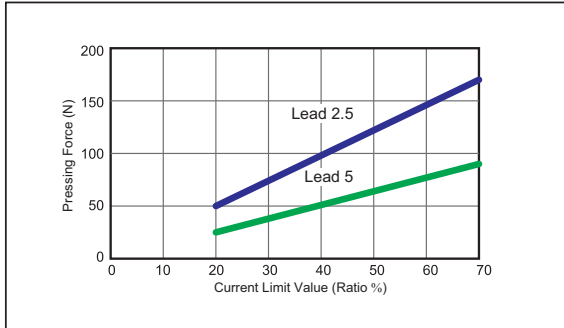

RCP2 Series

Slider Type

SA5C/SA6C/SS7C Type

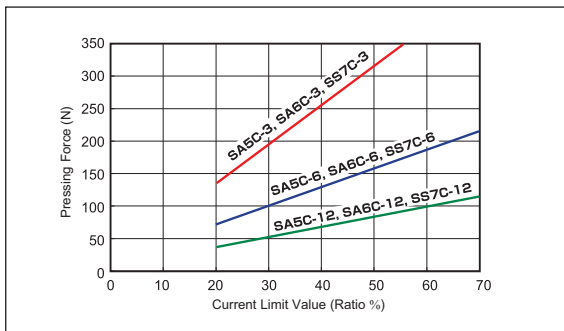

SA7C Type

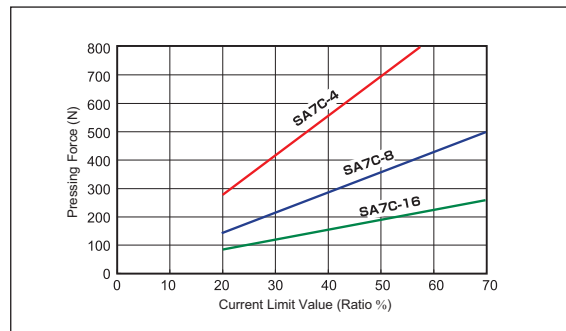

SA8C Type

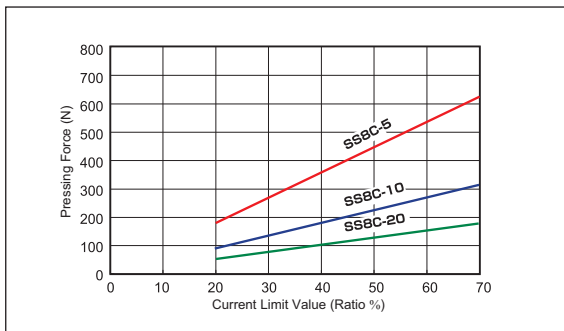

GRSS

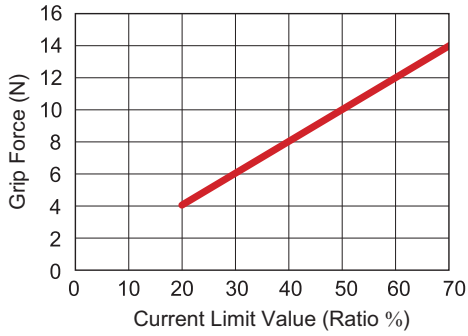

GRLS

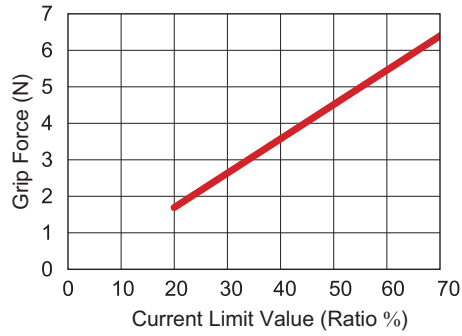

GRS

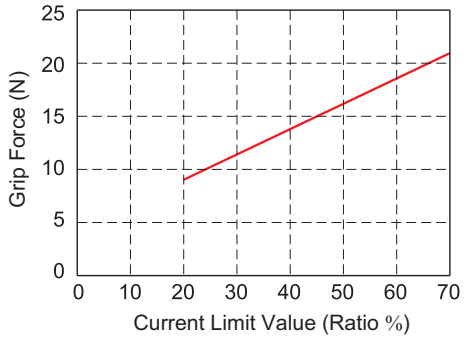

GRM

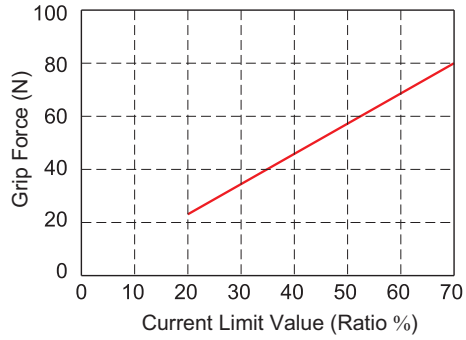

GRST

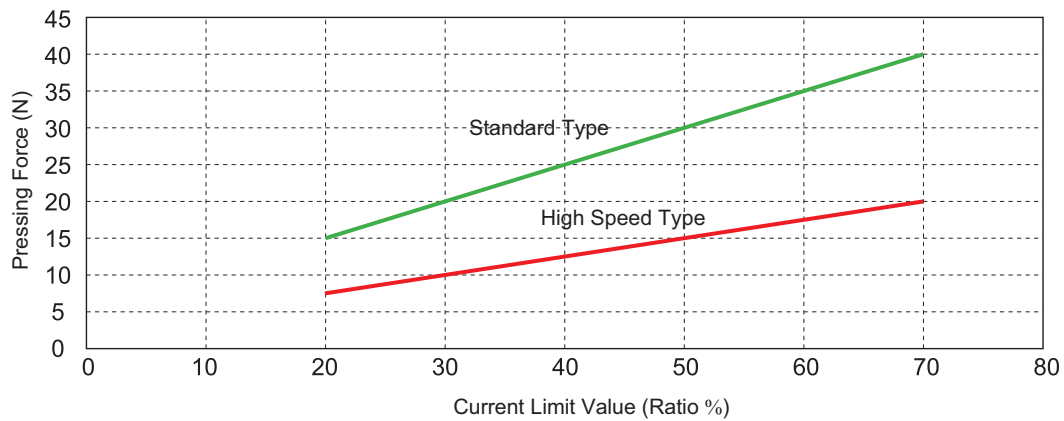

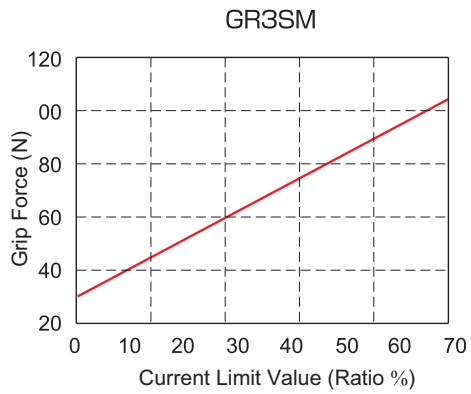
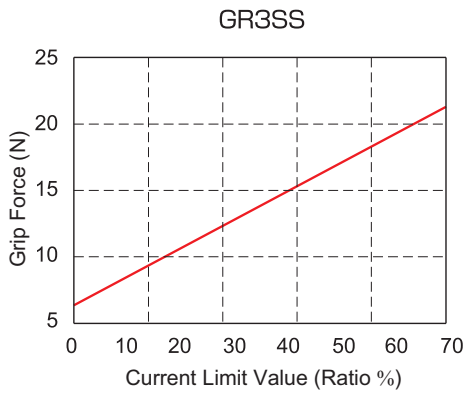
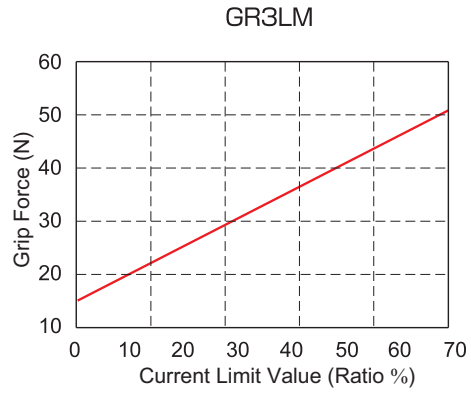
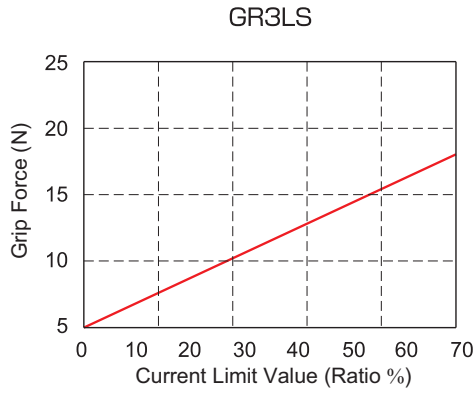

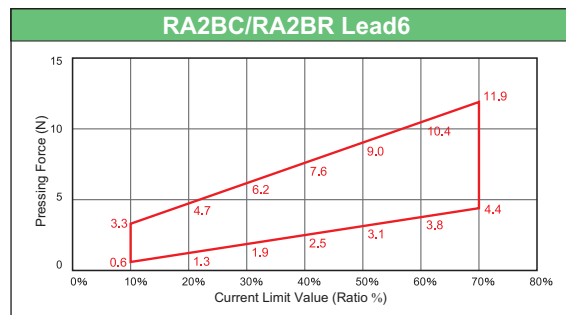
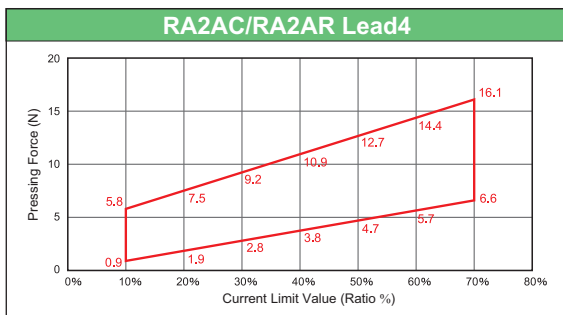
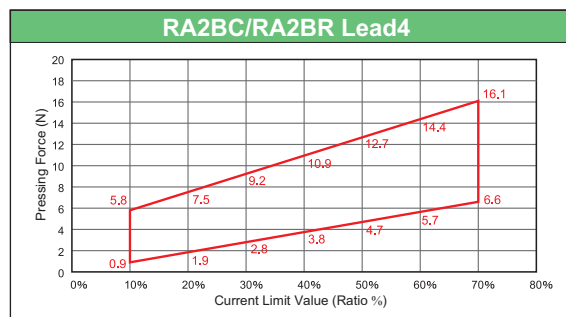
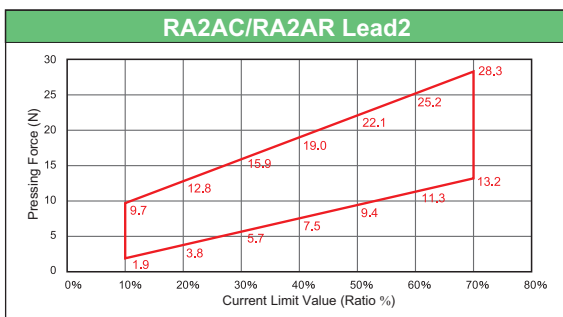
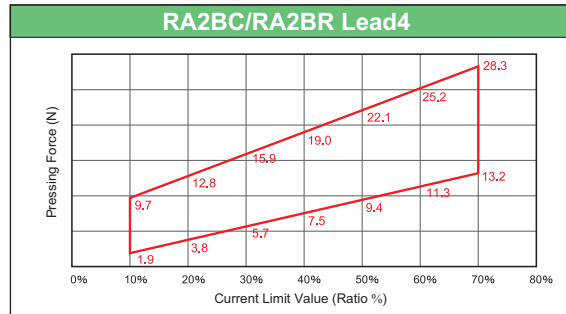
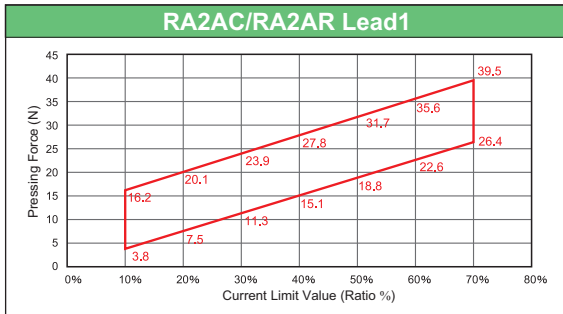

RCP3 Series

Slider Type

SA3C Type

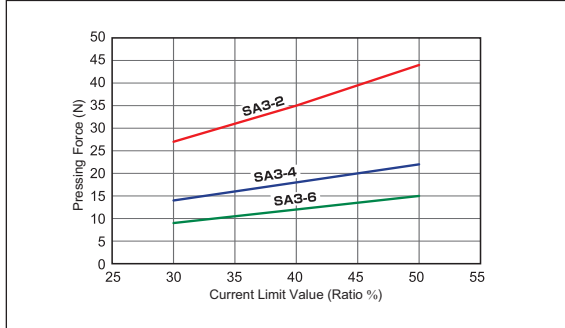

SA4C Type

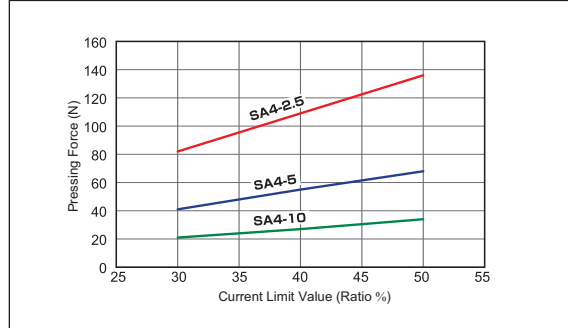

SA5C/SA6C Type

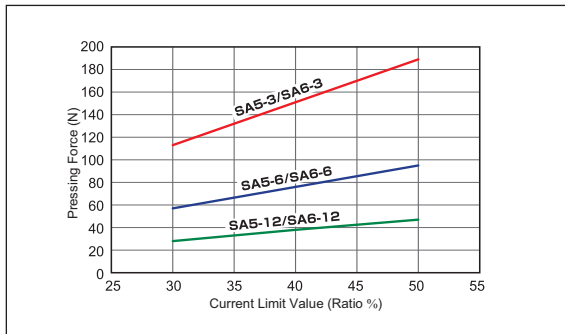

RCP3 Series

Thin and Small Table Type

TA3C Type

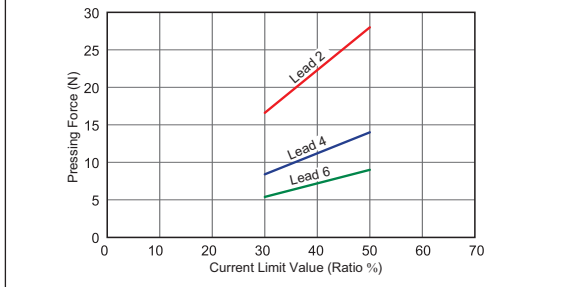

TA4C/TA4R Type

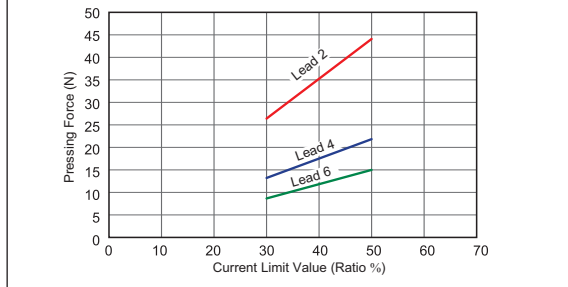

RCP3 Series

Table Type

TA5C Type

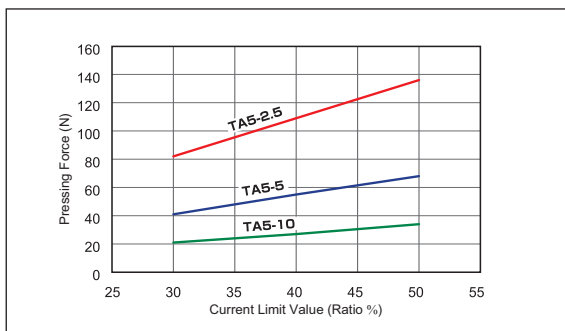

TA6C/TA7C Type

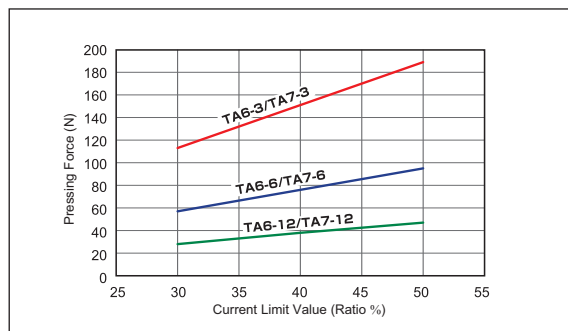

RCL Series

Micro Cylinder

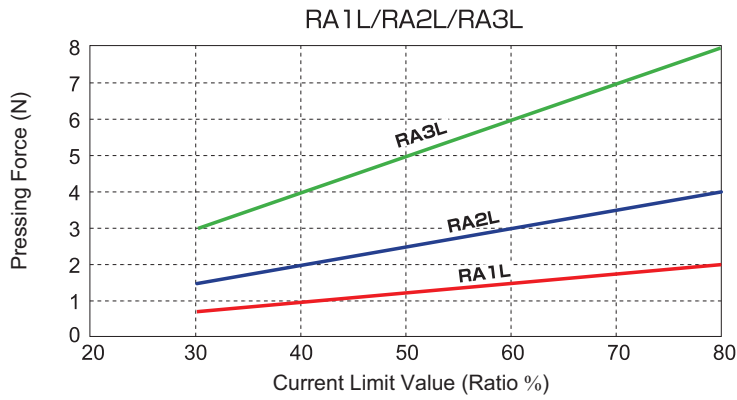

RCD Series

Ultra-small ROBO Cylinder

RA1D Type

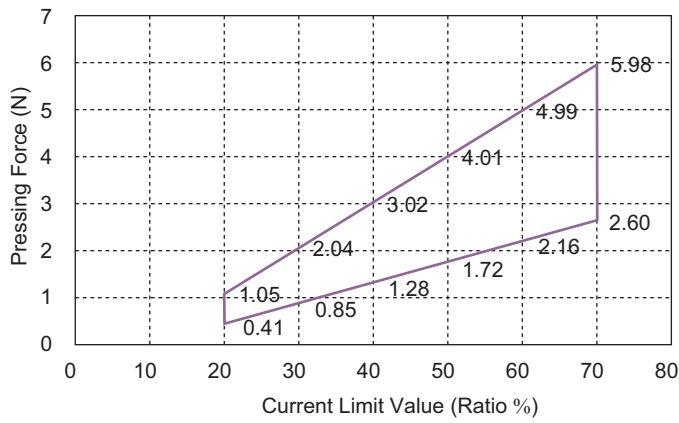

5. Warranty

5.1 Warranty Period

One of the following periods, whichever is shorter:

- 18 months after shipment from our factory
- 12 months after delivery to a specified location

5.2 Scope of Warranty

Our products are covered by warranty when all of the following conditions are met. Faulty products covered by warranty will be replaced or repaired free of charge:

- (1) The breakdown or problem in question pertains to our product as delivered by us or our authorized dealer.
- (2) The breakdown or problem in question occurred during the warranty period.
- (3) The breakdown or problem in question occurred while the product was in use for an appropriate purpose under the conditions and environment of use specified in the operation manual and catalog.
- (4) The breakdown or problem in question was caused by a specification defect or problem, or by the poor quality of our product.

Note that breakdowns due to any of the following reasons are excluded from the scope of warranty:

- [1] Anything other than our product
- [2] Modification or repair performed by a party other than us (unless we have approved such modification or repair)
- [3] Anything that could not be easily predicted with the level of science and technology available at the time of shipment from our company
- [4] A natural disaster, man-made disaster, incident or accident for which we are not liable
- [5] Natural fading of paint or other symptoms of aging
- [6] Wear, depletion or other expected result of use
- [7] Operation noise, vibration or other subjective sensation not affecting function or maintenance

Note that the warranty only covers our product as delivered and that any secondary loss arising from a breakdown of our product is excluded from the scope of warranty.

5.3 Honoring Warranty

As a rule, the product must be brought to us for repair under warranty.

5.4 Limited Liability

- (1) We shall assume no liability for any special damage, consequential loss or passive loss such as a loss of expected profit arising from or in connection with our product.
- (2) We shall not be liable for any program or control method created by the customer to operate our product or for the result of such program or control method.

5.5 Conditions of Conformance with Applicable Standards/ Regulations, Etc., and Applications

- (1) If our product is combined with another product or any system, device, etc., used by the customer, the customer must first check the applicable standards, regulations and/or rules. The customer is also responsible for confirming that such combination with our product conforms to the applicable standards, etc. In such a case we will not be liable for the conformance of our product with the applicable standards, etc.
- (2) Our product is for general industrial use. It is not intended or designed for the applications specified below, which require a high level of safety. Accordingly, as a rule our product cannot be used in these applications. Contact us if you must use our product for any of these applications
 - [1] Medical equipment pertaining to maintenance or management of human life or health
 - [2] A mechanism or mechanical equipment intended to move or transport people (such as a vehicle, railway facility or aviation facility)
 - [3] Important safety parts of mechanical equipment (such as safety devices)
 - [4] Equipment used to handle cultural assets, art or other irreplaceable items
- (3) Contact us at the earliest opportunity if our product is to be used in any condition or environment that differs from what is specified in the catalog or operation manual.

5.6 Other Items Excluded from Warranty

The price of the product delivered to you does not include expenses associated with programming, the dispatch of engineers, etc. Accordingly, a separate fee will be charged in the following cases even during the warranty period:

- [1] Guidance for installation/adjustment and witnessing of test operation
- [2] Maintenance and inspection
- [3] Technical guidance and education on operating/wiring methods, etc.
- [4] Technical guidance and education on programming and other items related to programs

Change History

Revision Date	Revision Description
2010.11	First Edition
2011.01	Second Edition P23 Pollution Standard Number changed from "EN60947-5-1" to "IEC60664-1"
2011.04	Third Edition Swapped over the page for CE Marking Explanation added regarding Absolute Battery
2011.07	Fourth Edition Contents changed and added in Appendix: List of Specifications of Connectable Actuators. Contents changed in Warranty in p. 105 to p. 106
2011.10	Fifth Edition Contents added in DSEP
2011.11	Sixth Edition Contents added in RCD



IAI Corporation

Head Office: 577-1 Obane Shimizu-KU Shizuoka City Shizuoka 424-0103, Japan
TEL +81-54-364-5105 FAX +81-54-364-2589
website: www.iai-robot.co.jp/

Technical Support available in USA, Europe and China

IAI America, Inc.

Head Office: 2690 W. 237th Street, Torrance, CA 90505
TEL (310) 891-6015 FAX (310) 891-0815
Chicago Office: 1261 Hamilton Parkway, Itasca, IL 60143
TEL (630) 467-9900 FAX (630) 467-9912
Atlanta Office: 1220 Kennestone Circle, Suite 108, Marietta, GA 30066
TEL (678) 354-9470 FAX (678) 354-9471
website: www.intelligentactuator.com

IAI Industrieroboter GmbH

Ober der Röth 4, D-65824 Schwalbach am Taunus, Germany
TEL 06196-88950 FAX 06196-889524

IAI (Shanghai) Co., Ltd.

SHANGHAI JIAHUA BUSINESS CENTER A8-303, 808, Hongqiao Rd. Shanghai 200030, China
TEL 021-6448-4753 FAX 021-6448-3992
website: www.iai-robot.com