

METRON MEASUREMENT LIGHT CURTAIN

CONTENTS

INTRODUCTION	2
MODELS	2
Beam Positioning	3
HOW TO INSTALL METRON	3
Mechanical Assembly and Optical Alignment	3
Multiple Systems	4
Distance from Reflective Surfaces	5
ELECTRIC CONNECTIONS	6
Warnings	6
Emitter Connections - A and B models	6
Emitter Connections - C models	7
Receiver Connections - A and B models	7
M16 12-pole Main Connector	7
M8 3-pole Programming Connector (RS-232) - A and B models	8
Receiver Connections - C models	8
Female Connector DB9 for Connecting to PC Serial Port (RS-232)	9
METRON - PC Connection Cable	9
Signals	9
DIMENSIONS	12
LIGHT CURTAIN TECHNICAL FEATURES	13
PROGRAMMING AND OPERATION OF STATIC OUTPUTS	14
OPERATION THROUGH SERIAL LINE RS-485	14
Using the <i>REER METRONCONF</i> Configuration Program	14
Preliminary Operations	15
METRON Configuration	16
Light Curtain Connection	17
Metron 4 OUT Configuration	17
MODEL 4 OUT FACTORY SETTINGS	20
METRON Configuration with Standard Serial Line RS-485	21
MODEL RS-485 FACTORY SETTINGS	24
SENT DATA PACKET CONFIGURATION ON RS-485	25
Metron Multinode Serial Line RS-485 Configuration	26
Configuration saving/opening	27
Send Configuration to Light Curtain	27
Light Curtain Configuration Reading	28
Light Curtain Disconnection	28
Light Curtain Status Monitoring	28
WARRANTY	31

 METRON light curtains **MUST NOT** be used as safety devices for protection of operators in dangerous areas.

INTRODUCTION

The METRON light curtain is a multibeam optoelectronic system, composed of an Emitter unit and a Receiver unit, used for the detection or measurement of objects of dimensions up to 2500mm. Synchronisation between the two units can take place via optical link or via cable (with optical link only in METRON C models).

The barrier output conditions (resident in the receiver) vary as soon as a measurement is made (or an object is detected).

MODELS

Metron is available in 3 different model families (A, B and C) with variable heights and resolutions:

- *MODELS A*: Models for the measurement of objects, with controlled field from 150mm to 2500mm and resolution equal to 5/10/25/30/50/75mm, which have 4 static outputs. These are activated when one or more conditions requested by the user are detected.
- *MODELS B*: Models for the measurement of objects, with controlled field from 150mm to 2500mm and resolution equal to 5/10/25/30/50/75mm, which have a RS-485 communication line and 2 static outputs. These are activated when one or more conditions requested by the user are detected.
- *MODELS C*: Models for the measurement of objects, with controlled field from 150mm to 2500mm and resolution equal to 5/10/25/30/50/75mm, which have 2 antivalent static outputs which change status on the interruption / release of the controlled field.

Beam Positioning

The following figure shows the arrangement of beams and their numbering:

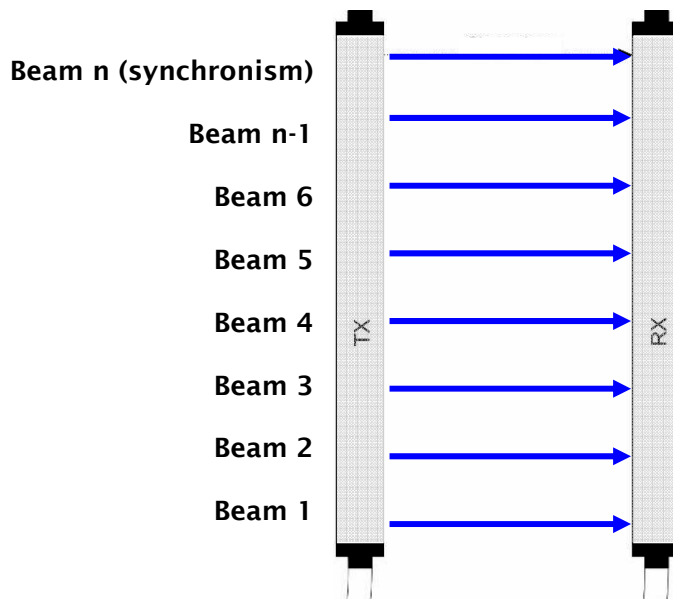

Figure 1

- ➔ It is important to note that the beam numbering starts from the bottom, as shown in the figure. If synchronism is by cable, even the last beam can also be used for measurement.
- ➔ When the optical synchronism is used, the last beam towards the top must never be used to avoid interruption of the measuring function.

HOW TO INSTALL METRON

Mechanical Assembly and Optical Alignment

The Emitter and the Receiver must be assembled in front of each other at a distance equal to or lower than that indicated in the technical data; using the supplied inserts and fastening brackets, place the Emitter and the Receiver in such a way that they are aligned and parallel, with the connectors facing the same side.

According to the size and shape of the support on which the Emitter and the Receiver are to be mounted, the fixtures can be positioned on the back, or they can be inserted into the side groove (Figure 2).

Perfect alignment between the Emitter and the Receiver is essential to ensure correct operation of the light curtain; This procedure is facilitated by observing the Emitter and the Receiver signal LEDs.

To make alignment between the Emitter and the Receiver easier, the SFB circular brackets can be used, which are available by order (code 1330974).

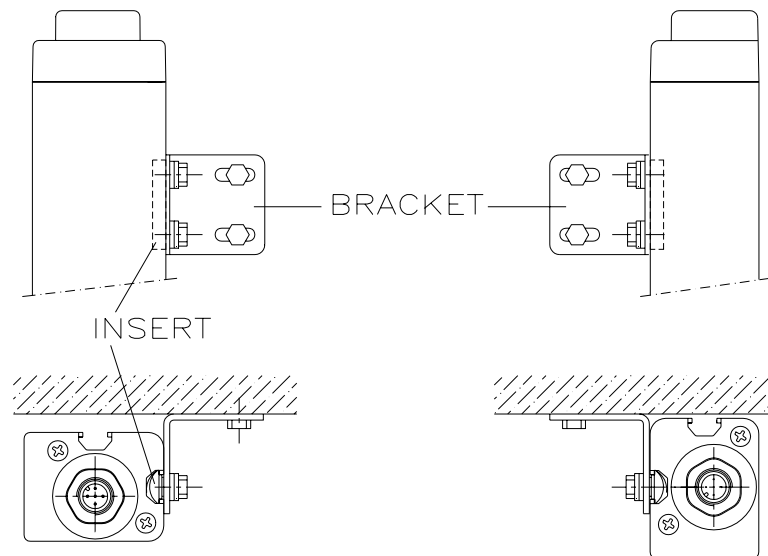

Figure 2

- Align the first and last beams of the Emitter with the corresponding beams on the receiver.
- Move the Emitter to find the area in which the green LED on the Receiver remains on.
- Secure the Emitter and the Receiver in position.
- If you are using the optical synchronism (first beam on the top, Figure 1), a flashing "o" on the Receiver's display means that the synchronism beam is not aligned.

Multiple Systems

When a number of METRON systems are used, optical interference between them and with other optical sensors should be avoided: position the elements in such a way that the beam emitted by the Emitter of a system is only received by its corresponding Receiver.

Figure 3 shows some examples of the correct positioning between the two light curtain systems. Incorrect positioning could generate interference, leading to possible malfunctioning.

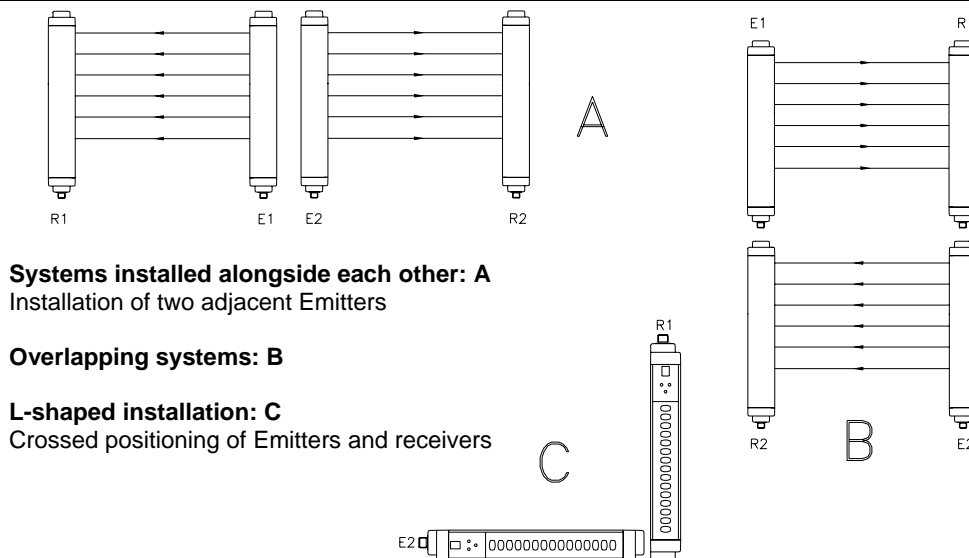

Figure 3

Distance from Reflective Surfaces

The presence of reflective surfaces near the light curtain may cause spurious reflections which prevent detection. In Figure 4, object A is not detected due to surface S, which by reflecting the beam closes the optical path between the Emitter and the Receiver. Therefore, a certain distance (refer to the following warnings) should be maintained between any reflective surfaces and the sensitive area.

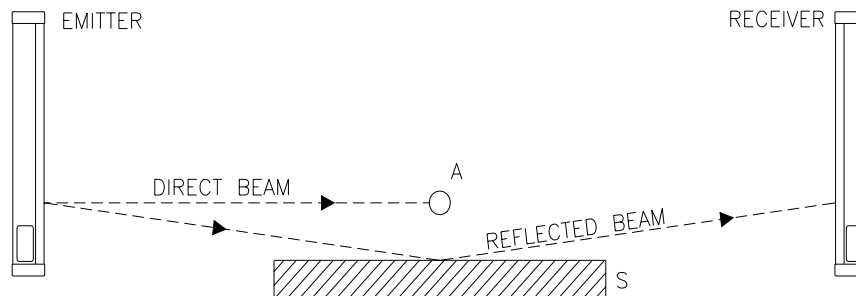

Figure 4

Once installed, verify the presence of any reflective surfaces that may be intercepting the beams, first in the middle and then in the proximity of the Emitter and the Receiver. During this procedure the red LED on the Receiver must not turn off under any circumstance.

- ➔ To reduce the reflection phenomenon (in models 5-25-50-75mm) it could be useful to set the **"reduced sensitivity"** with the METRONCONF Programme (see Page 19).
- ➔ In any case, a reflective surface must never be present at a distance under 30cm.

ELECTRIC CONNECTIONS

Warnings

Before carrying out the electrical connections, please ensure that the available power supply is in compliance with that indicated in the technical data.

➔ Emitter and Receiver must have a power supply of 24Vdc±20%.

- In order to guarantee reliability of operation, using a diode bridge on the power supply, output capacity must be at least 2000µF for each A of absorption.

Emitter Connections - A and B models

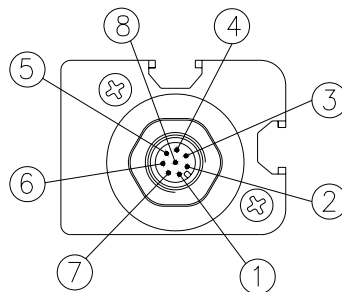

Figure 5

PIN	NAME	DESCRIPTION
1	SYNC A	TX-RX Synchronism
2	24 VDC	Power supply (positive)
3	SYNC B	TX-RX Synchronism
4	SEL RANGE	Range selection
		0VDC -> Low range 24VDC -> High range
5	SEL ORIENT	Orientation selection
		0VDC -> Normal orientation 24VDC -> Upside-down orientation
6	N.C.	-
7	0 VDC	Power supply (negative)
8	PE	Earth connection

Table 1

- ➔ If synchronisation by cable is to be used, pins 1 and 3 must be connected to the respective signals (pin B and D) on the receiver column. In this case, synchronisation is ensured even in the absence of all beams (completely obstructed light curtain).
- ➔ If synchronisation via cable is not necessary, leaving pins 1 and 3 free will activate optical synchronisation and the synchronism beam will be the first on top (the most distant from the connector).
- ➔ In both cases, if the synchronism function is lost (faulty connection or interrupted synchronism beam) the METRON measurement function will be lost, outputs will be reset to zero and the transmission of data packages will be interrupted (model with RS-485).

Emitter Connections - C models

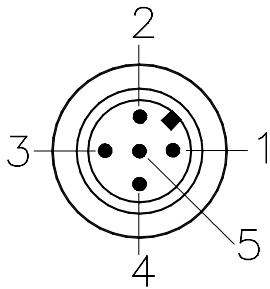

Figure 6

PIN	NAME	DESCRIPTION
1	24 VDC	Power supply (positive)
2	RANGE SEL	Range selection 0VDC -> Low range 24VDC -> High range
3	0 VDC	Power supply (negative)
4	N.C.	-
5	PE	Ground connection

Table 2

Receiver Connections - A and B models

The receiver is equipped with an M16, 12-pole main connector and, on configurable models (see section "CONFIGURATION (SERIAL LINE RS-232) AND FUNCTIONALITY USING SERIAL LINE RS-485" , of an M8, 3-pole configuration connector (RS-232).

M16 12-pole Main Connector

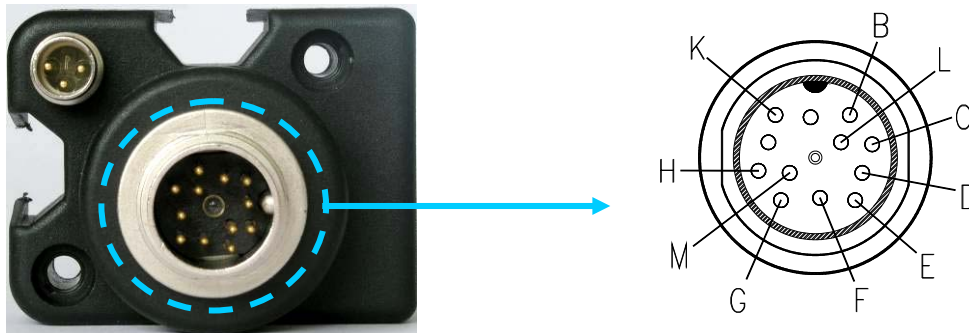

Figure 7

Regarding the Receiver, several models will be available:

- A) Model with 4 solid state outputs and one input (with configurable functionality through a serial line).

PIN	NAME	DESCRIPTION
H	24 Vdc	Power supply (positive)
L	0 Vdc	Power supply (negative)
K	PE	Ground connection
C	OUT1	Static output 1 : 100mA @ 24VDC
M	INPUT	Digital input with programmable function
G	OUT2	Static output 2 : 100mA @ 24VDC
B	SYNC A	TX-RX Synchronism
D	SYNC B	TX-RX Synchronism
F	OUT3	Static output 3 : 100mA @ 24VDC
E	OUT4	Static output 4 : 100mA @ 24VDC

Table 3

B) Model with one input, two solid state outputs (with configurable functionality through a serial line) synchronisation by cable and RS-485 serial communication line (for data analysis).

PIN	NAME	DESCRIPTION
H	24 Vdc	Power supply (positive)
L	0 Vdc	Power supply (negative)
K	PE	Ground connection
C	OUT1	Static output 1 : 100mA @ 24VDC
M	INPUT	Digital input with programmable function
G	OUT2	Static output 2 : 100mA @ 24VDC
B	SYNC A	Synchronism TX-RX
D	SYNC B	Synchronism TX-RX
F	LINE + (B)	RS-485+(B) Serial line
E	LINE - (A)	RS-485-(A) Serial line

Table 4

➔ If using an RS-485 serial line, connect pins F,E and L (0 Vdc).

M8 3-pole Programming Connector (RS-232) - A and B models

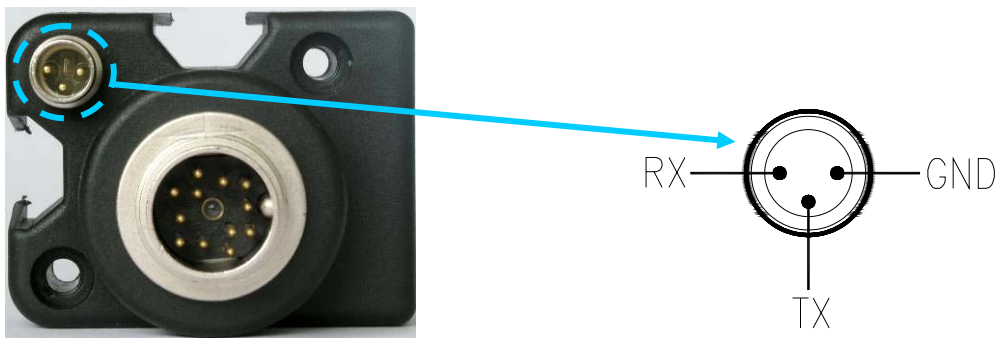

Figure 8

The male connector beside the receiver power supply main connector represented in Figure 8 allows METRON to connect with the serial port of a Personal Computer.

Receiver Connections - C models

C) Model with 2 solid state outputs.

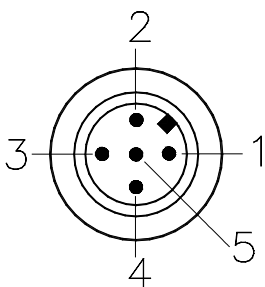

Figure 9

PIN	NAME	DESCRIPTION
1	24 VDC	Power supply (positive)
2	OUT1	Static output 1 : 100mA @ 24VDC DARK-ON
3	0 VDC	Power supply (negative)
4	OUT2	Static output 2 : 100mA @ 24VDC LIGHT-ON
5	PE	Ground connection

Table 5

Female Connector DB9 for Connecting to PC Serial Port (RS-232)

The following table shows the signals which must be carried to the PC serial port using a female DB9 connector.

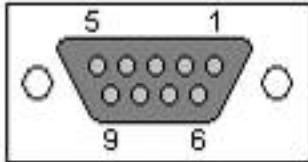

Figure 10

PIN	NAME	DESCRIPTION
2	TX	Transmission line
3	RX	Reception line
5	GND	Ground connection

Table 4

METRON - PC Connection Cable

REER can supply (upon request) a METRON-PC connecting cable equipped with two connectors:

- (1) female plug link cable connector DB9 (to connect to the serial port of the PC).
- (2) M8 female 3-poles connector (to connect to the METRON receiver).



Figure 11

Signals

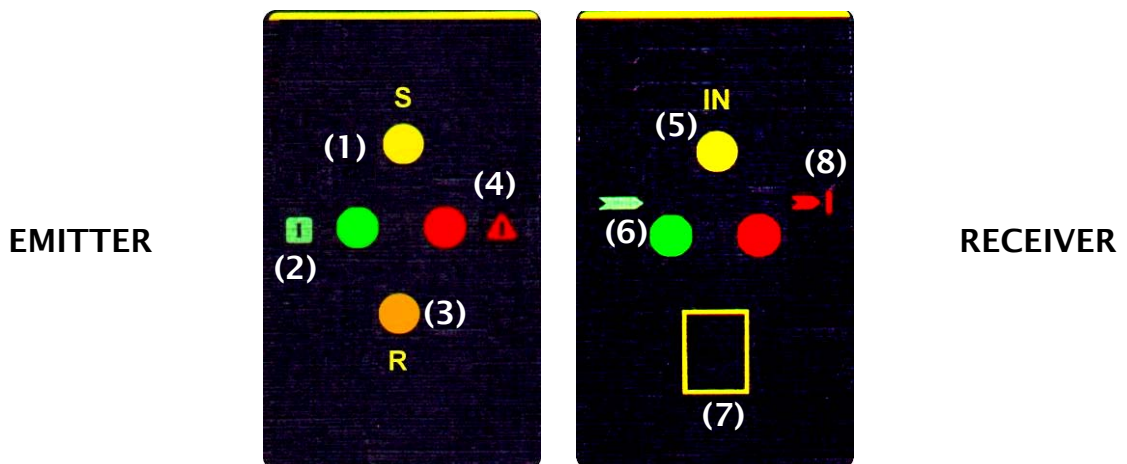

Figure 12

EMITTER - A and B models

LED 1 YELLOW	LED 2 GREEN	LED 3 ORANGE	LED 4 RED	INDICATION
ON	Off	ON	ON	System start.
ON	ON	Off	Off	Operation with optical synchronism low range *
ON	ON	ON	Off	Operation with optical synchronism high range *
Off	ON	Off	Off	Operation with synchronism by cable low range
Off	ON	ON	Off	Operation with synchronism by cable high range
Flashes every 0,4s	off	Off	ON	Lack of synchronism by cable (if set)
Flashes every 0,1s	Off	Off	ON	Synchronism mode change
Off	Off	Flashes every 0,1s	ON	Range input error
Flashes every 0,1s	Off	Flashes every 0,1s	ON	Internal failure

Table 6

* In the case of upside-down orientation, LED 1 will flash 3 times before normal operation.

EMITTER - C models

LED 1 YELLOW	LED 2 GREEN	LED 3 ORANGE	LED 4 RED	INDICATION
ON	off	ON	ON	System start.
ON	ON	off	off	Operation low range
ON	ON	ON	off	Operation high range
off	off	Lamp. every 0,1s	ON	Range input error
Lamp. every 0,1s	off	Lamp. every 0,1s	ON	Internal failure

Table 7

RECEIVER - A and B models

LED 5 YELLOW	LED 6 GREEN	LED 8 RED	7 DISPLAY	INDICATION
ON	off	ON	8	System start.
-	ON	off	o	Operation with optical synchronism, controlled field clear
-	off	ON	o	Operation with optical synchronism, controlled field in use
-	off	ON	o (flashing)	Operation with optical synchronism, synchronism beam in use
-	ON	off	c	Operation with synchronism by cable, controlled field clear
-	off	ON	c	Operation with synchronism by cable, controlled field in use
-	off	ON	c (flashing)	Operation with synchronism by cable, lack of synchronism by cable
off	-	-	-	Lack of INPUT
ON	-	-	-	Active INPUT
off	off	ON	P	Connected configurator
off	off	ON	P (flashing)	End configurator connection
off	off	ON	A (flashing+ F)	Optical card failure
off	off	ON	E (flashing + F)	Microcontroller card failure
off	off	ON	C (flashing+ F)	Configuration error

Table 8

RECEIVER - C models

LED 5 YELLOW	LED 6 GREEN	LED 8 RED	7 DISPLAY	INDICATION
ON	off	ON	8	System start
-	ON	off	o	Controlled field clear
-	off	ON	o	Controlled field in use
-	off	ON	o (lamp.)	Synchronism beam in use
off	off	ON	A (lamp.+ F)	Optical card failure
off	off	ON	E (lamp.+ F)	Microcontroller card failure

Table 9

DIMENSIONS

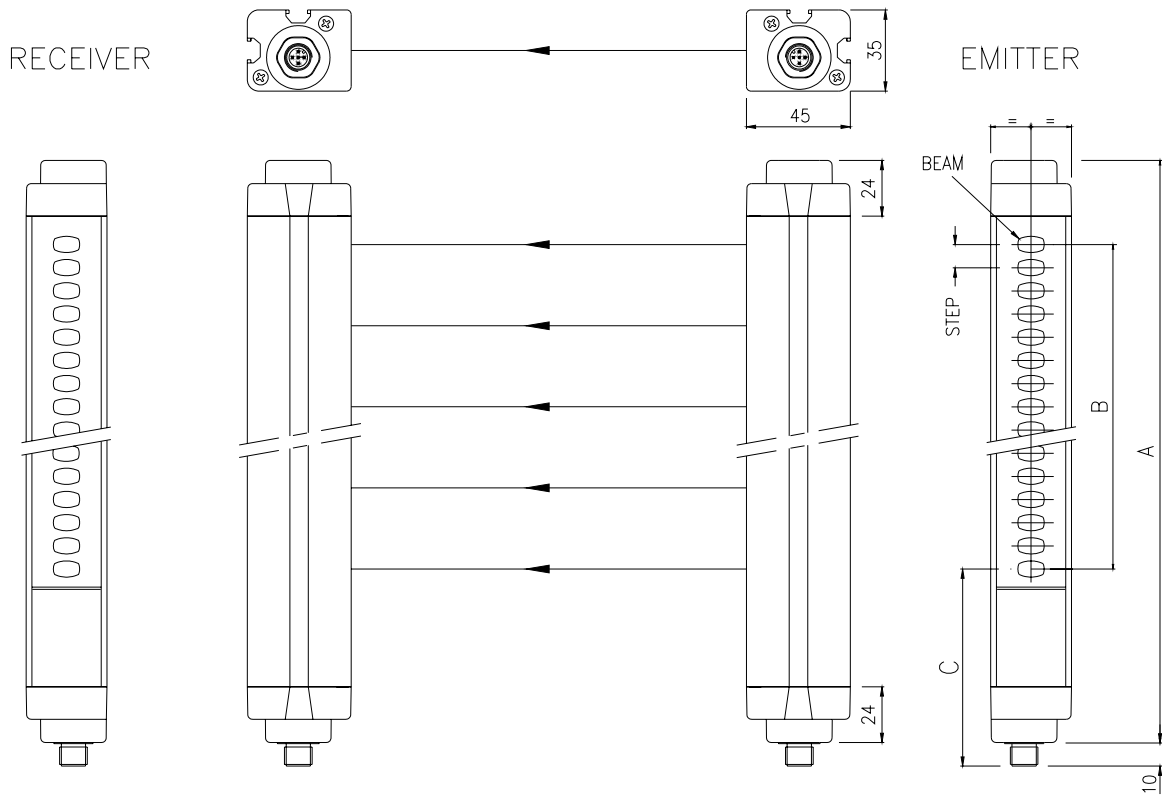

ME Model	150	300	450	600	750	900	1050	1200
A	251	401	551	701	851	1001	1151	1301
B (Measurement Height)	$B = (\text{beams number} - 1) \times \text{step}$ (with cable synchronism) $B = (\text{beams number} - 2) \times \text{step}$ (with optical synchronism) *							
C (1st beam Height)	85 (for 10 and 30 models) - 93 (for 25, 50 and 75 models)							
Mounting	2 LS brackets with 2 mounting inserts							

ME Model	1350	1500	1650	1800	1950	2100	2250	2400	2550
A	1451	1601	1751	1901	2051	2201	2351	2501	2651
B (Measurement Height)	$B = (\text{beams number} - 1) \times \text{step}$ (with cable synchronism) $B = (\text{beams number} - 2) \times \text{step}$ (with optical synchronism) *								
C (1st beam Height)	85 (for 10 and 30 models) - 93 (for 25, 50 and 75 models)								
Mounting	3 LS brackets with 3 mounting inserts								

* In the case of optical synchronism, the beam beside the upper cover cap cannot be used for the measurement as it is the synchronism beam.

LIGHT CURTAIN TECHNICAL FEATURES

METRON LIGHT CURTAIN TECHNICAL FEATURES - A and B models			
Measurement Height	mm	150 - 2500	
Space between beams	mm	5 - 10 - 25 - 30 - 50 - 75	
Working range	m	5mm	0,2÷1 / 0,8÷2
		10 - 30mm	0÷6 / 1÷16
		25 - 50 - 75mm	0,2÷2,5 / 1,5÷6
Power supply	VDC	24 ± 20%	
Connections		M12 - 8-pole Emitter M16 - 12-pole Receiver (M8 for RS-232 serial configuration)	
Measurement time		(2.25 ms + 70 µs x nbeams) x 2	
Synchronisation Mode		Optical or by cable, selectable	
Length max. connect.	m	50	
Operating temp.	°C	0 ÷ 55°C	
Degree of Protection		IP 65	
Section dimensions	mm	35 x 45	
Max. power consumption	W	2 (Emitter) 2 (Receiver)	
Output		Up to 4 static outputs of 100mA @ 24VDC (configurable function)	
Communication lines		RS-485 (up to 8 nodes) for measuring data RS-232 for programming	
Inputs		Inputs for Enable/Disable/Strobe	

METRON LIGHT CURTAIN TECHNICAL FEATURES - C models			
Measurement Height	mm	150 - 2500	
Space between beams	mm	5 - 10 - 25 - 30 - 50 - 75	
Working range	m	5mm	0,2÷1 / 0,8÷2
		10 - 30mm	0÷6 / 1÷16
		25 - 50 - 75mm	0,2÷2,5 / 1,5÷6
Power supply	VDC	24 ± 20%	
Connections		M12 - 5 poles	
Measurement time		(2.25 ms + 70 µs x nbeams) x 2	
Length max. connect.	m	50	
Operating temp.	°C	0 ÷ 55°C	
Degree of Protection		IP 65	
Section dimensions	mm	35 x 45	
Max. power consumption	W	2 (Emitter) 2 (Receiver)	
Output		2 static outputs of 100mA @ 24VDC 1 DARK-ON + 1 LIGHT-ON	

PROGRAMMING AND OPERATION OF STATIC OUTPUTS

The function programming system, allows the operation associated with each output to be selected (see section "*Using the REER METRONCONF configuration program*").

These functions can be divided into basic functions and advanced functions. The basic functions allow one of the outputs to be activated in the event that a preset condition occurs, which may be dependent on another condition (using the conventional logical operators AND/OR).

Example: Activate output No. 1 if the obstructed beam is number 12; activate output No. 2 if the last obstructed beam is number 15 AND the total number of obstructed beams is more than 6.

OPERATION THROUGH SERIAL LINE RS-485

Using the *REER METRONCONF* Configuration Program

METRON is equipped with a 3-pin connector on the receiver (see section about connections) for connection to a personal computer using a serial line RS-232.

METRON configuration can be achieved using the function programming system (*REER METRONCONF*) for the following:

- Configuration of serial line RS-485 (baud rate, parity, start and stop characters and format: binary, hex, ascii, etc.).
- Setting of conditions (also in combination with the operators AND / OR) which allow activation of the outputs. The following conditions can be selected:
 - **FBO** First obstructed beam
 - **LBO** Last obstructed beam
 - **CBO** Central obstructed beam *
 - **NBO** Number of occupied beams
 - **NCBO** Maximum number of consecutively obstructed beams *
 - **BNO** beam **n** obstructed

* If several zones are obstructed , the data refers to the zone with the highest number of obstructed beams.

A graphic interface can also be displayed for real-time monitoring of light curtain conditions.

The following figures illustrate some screens from the *REER METRONCONF* program, through which the user can configure *METRON*'S operating logic.

Preliminary Operations

Insert the METRONCONF CD-ROM in the computer and follow the instructions for software installation. To launch METRONCONF double click on the icon created on the desktop.

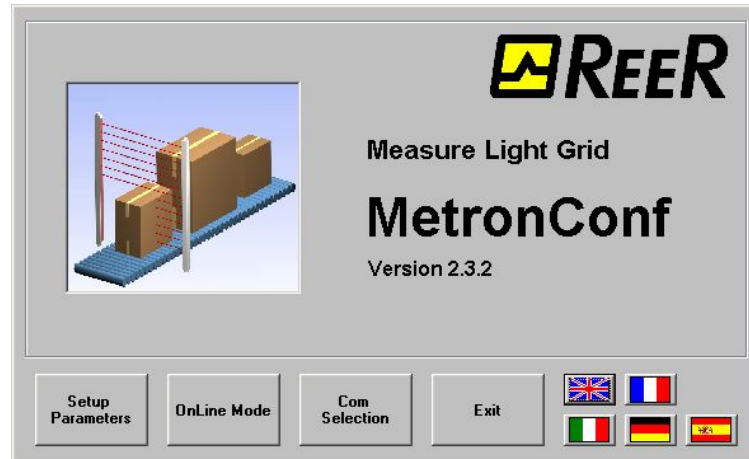

Figure 13 – Opening Screen

The various buttons on the initial screen allow the operator to go to different environments for the following specific purposes :

- ➔ METRON configuration ("SETUP PARAMETERS" button) (see page 15)
- ➔ Monitoring the light curtain status ("ON LINE MODE" button) (see page 28).
- ➔ Selecting the required serial port for connection via RS-232 ("COM SELECTION" button) (see below).
- ➔ Language selection.

Figure 12 shows the computer serial port selection screen. Use the "COM SELECTION" button to activate it.



Figure 14 - Select Serial Port

METRON Configuration

After pressing the "SETUP PARAMETERS" button, the following screen will appear:

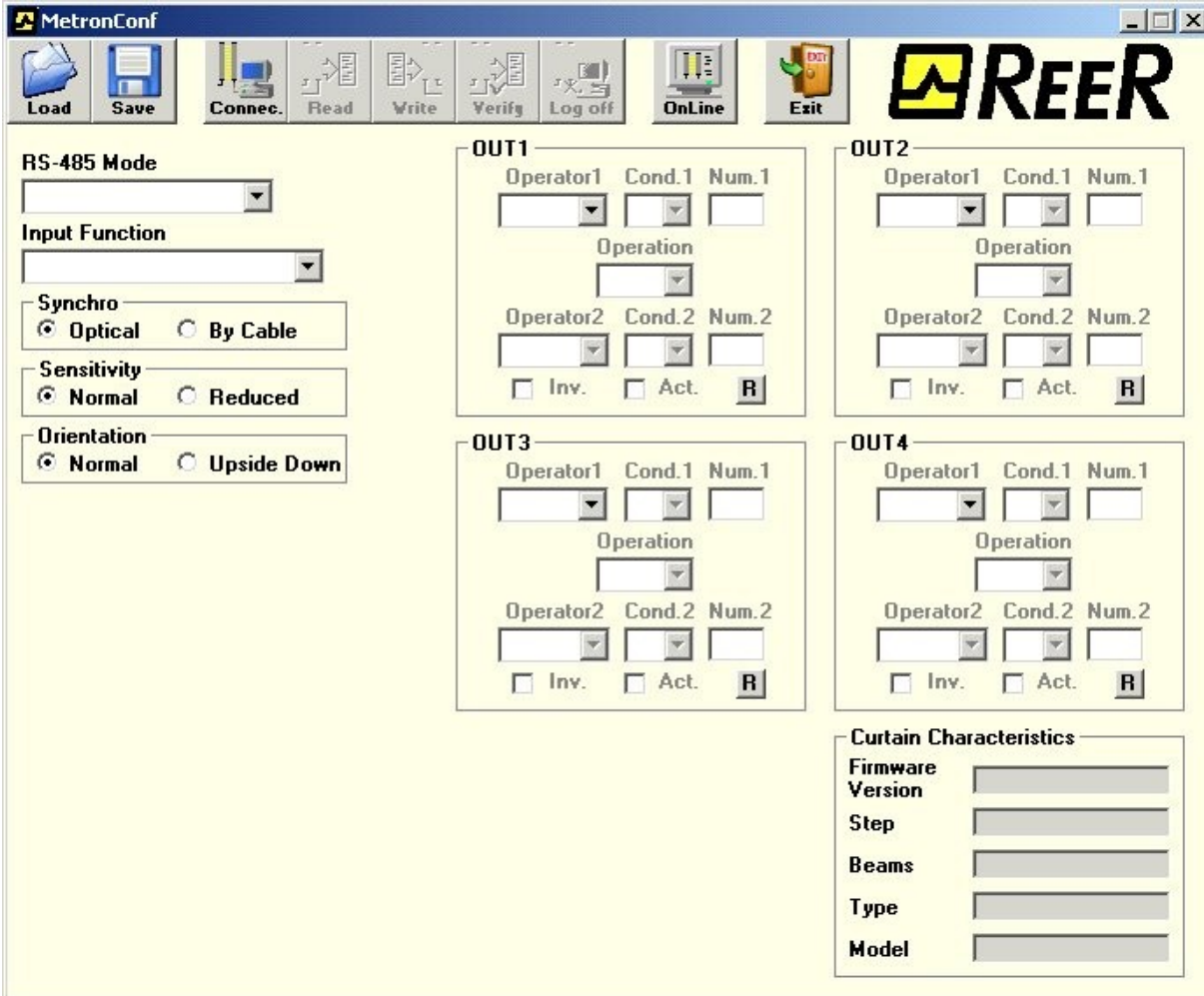



Figure 15

Even when the light curtain is not connected, the configuration fields can be filled in and the configuration can be saved on the computer using the  icon .

A previously saved configuration can be recalled subsequently by the operator .

Light Curtain Connection

Select the  icon to activate the METRON connection to the computer.

When the connection has been established, the "CURTAIN CHARACTERISTICS" (1) panel in the bottom right corner is automatically completed (Figure 14).

At this stage the light curtain's measuring function is lost as the programming mode is activated (the letter "P" will appear on the receiver's display).

At the end of the programming phase, remember to follow the "DISCONNECTION" procedure in order to reactivate the light curtain:

Select the  icon in order to disconnect the light curtain. After approximately 10 seconds the light curtain will become active again using the last configuration sent to it.

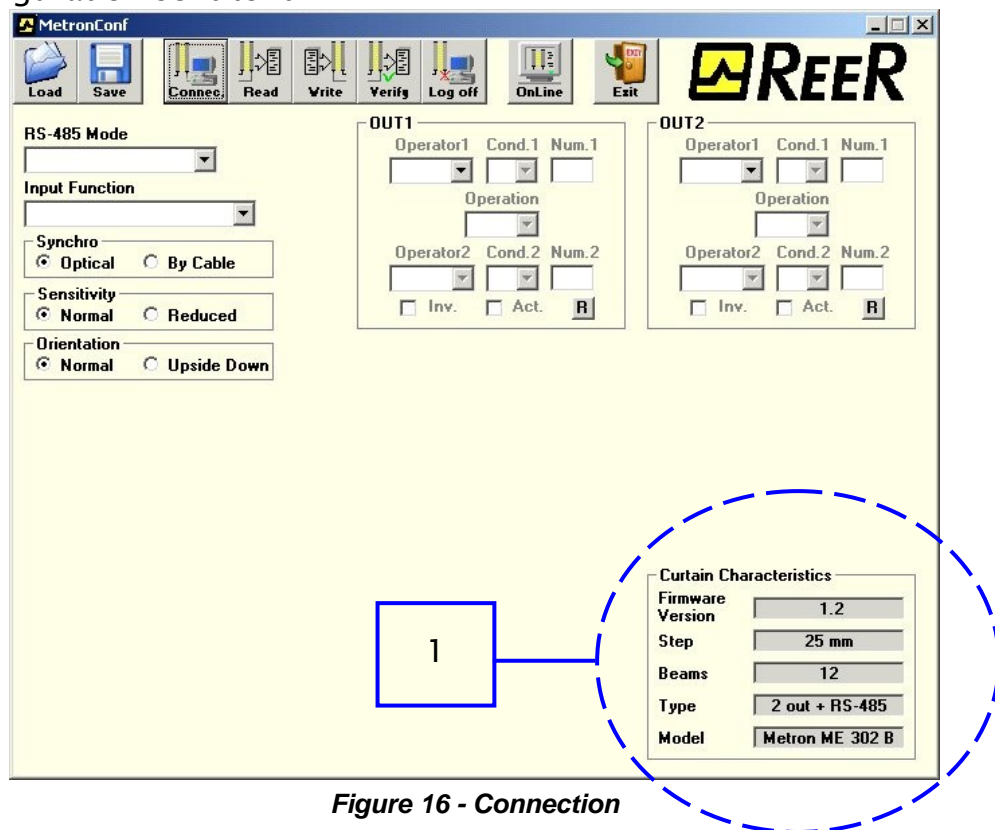

Figure 16 - Connection

Metron 4 OUT Configuration

Figure 15 shows the condition configuration screen (in which the operators AND / OR can also be used) through which the 4 outputs can be activated. Select the "No line" option in the "RS-485 MODE" drop-down menu .

In the example in Figure 15, the following conditions are active:

OUT1) Number of obstructed beams ≥ 1

OUT2) First obstructed beam ≥ 10 AND Last obstructed beam ≤ 20

OUT3) Beam N° 29 obstructed (OUT3 active low)

OUT4) Number of consecutively obstructed beams ≥ 5 OR Number of consecutively obstructed beams ≤ 10

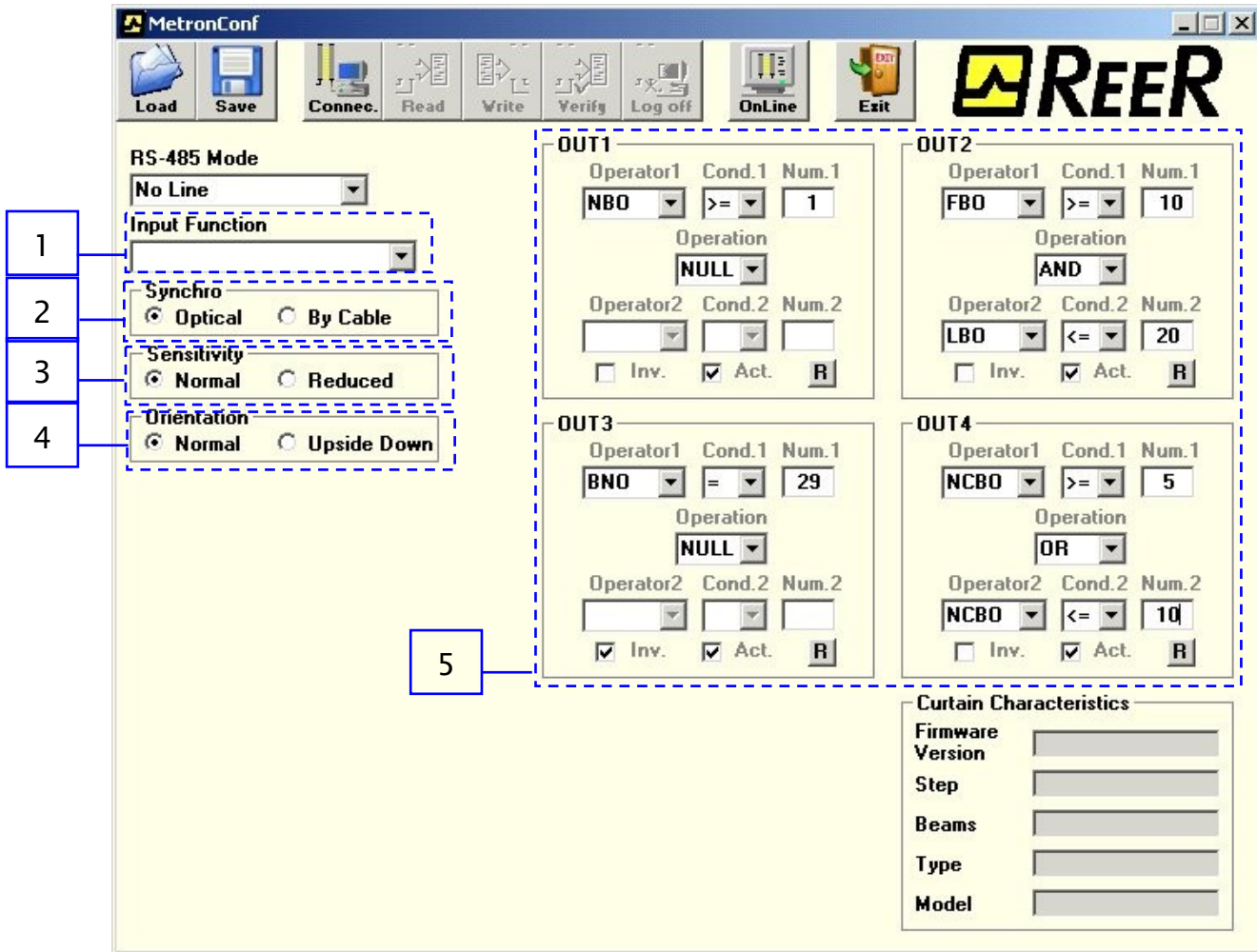

Figure 17 - METRON 4 OUT Configuration

- 1** **Input function configuration:**
 The light curtain input signal (INPUT-pin M) (*minim um duration = 100ms, active high*) function can be programmed . The various options are as follows :

NO FUNCTION	The outputs are activated when preset conditions occur
OUTPUT ENABLE	Enables and disables the required operation of the various outputs
OUTPUT STAND-BY	Freezes the last output condition
OUTPUT START/STOP	Establishes start and end of a measurement session. The outputs are activated in the t_1 instant (Figure 16) only if the preset conditions are met in this timeframe (example. NBO>=1)

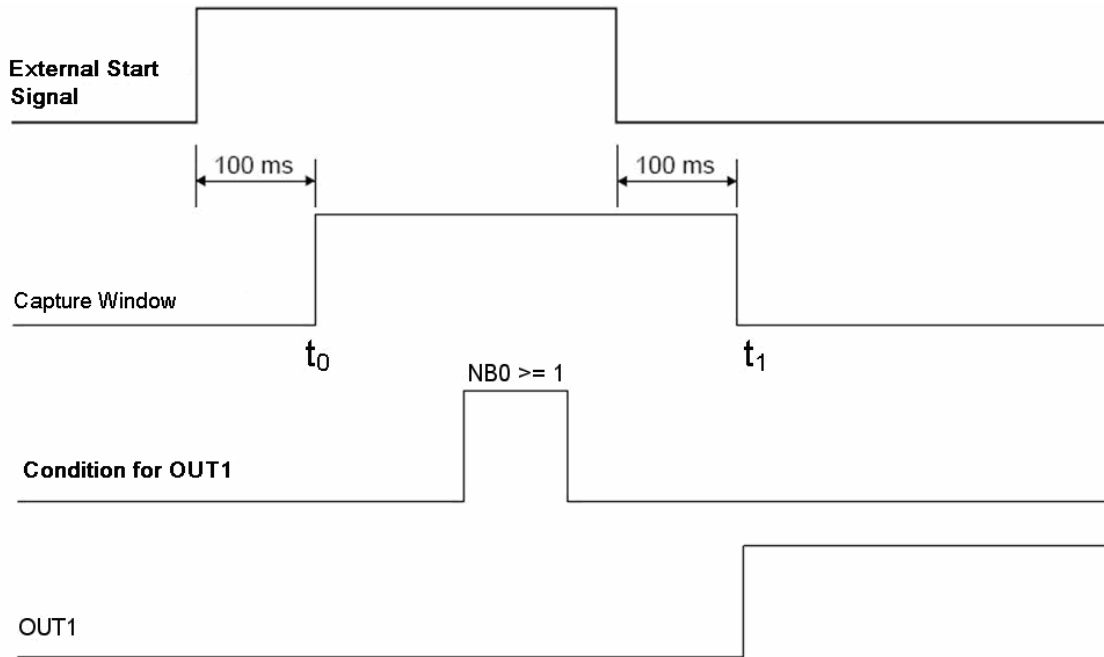

Figure 18 –START/STOP Output

2 Synchronism Configuration:

The synchronisation between TX and RX can be programmed in the following modes :

SYNCHRO BY CABLE	Synchronisation is carried out by connecting the two emitter and receiver signal pairs SYNC A and SYNC B .
SYNCHRO OPTICAL	Synchronisation is achieved by using the last beam of the light curtain.

- ➔ When optical synchronism is used, the last beam towards the top must not be obstructed otherwise the measurement function will be interrupted.
- ➔ To switch from cable to optical synchronism, the emitter must be turned off and restarted.

3 Sensitivity Configuration:

It is possible to modify the receiver’s sensitivity depending on the distance from the Emitter.

NORMAL SENSITIVITY	Recommended for $d > 50\text{cm}$
REDUCED SENSITIVITY	Recommended for $d < 50\text{cm}$

- ➔ When reduced sensitivity is used, it is recommended to select the lower range on the emitter (see Table 1).

4 Orientation Configuration:

Beam numbering can be configured based on the light curtain's orientation:

NORMAL ORIENTATION	Connectors down - first beam down
UPSIDE DOWN ORIENTATION	Connectors up - first beam down

- ➔ When upside-down orientation is used, this should also be selected on the emitter (see Table 1).
- ➔ In case of optical synchronism, the synchronism beam will **always be the last beam up**.

5 Output Configuration:

The conditions that cause the activation of individual outputs can be programmed (see Page 12).

- Using box **INV.** , the output logic can be inverted.
- Using box **ACT.** , the output itself can be activated/deactivated.
- The **R** switch allows all the fields of each individual output to be reset.

MODEL 4 OUT FACTORY SETTINGS

INPUT FUNCTION	No function
SYNCHRONISM	Optical
STATIC OUTPUT	OUT1 active
CONDITION FOR OUT1	NB0 >= 1 (presence control)
ORIENTATION	Normal
SENSITIVITY	Normal

METRON Configuration with Standard Serial Line RS-485

Figure 17 shows the serial RS-485 configuration screen . Select the "RS-485 Standard" option from the " MODALITYLINE RS-485" drop-down menu.

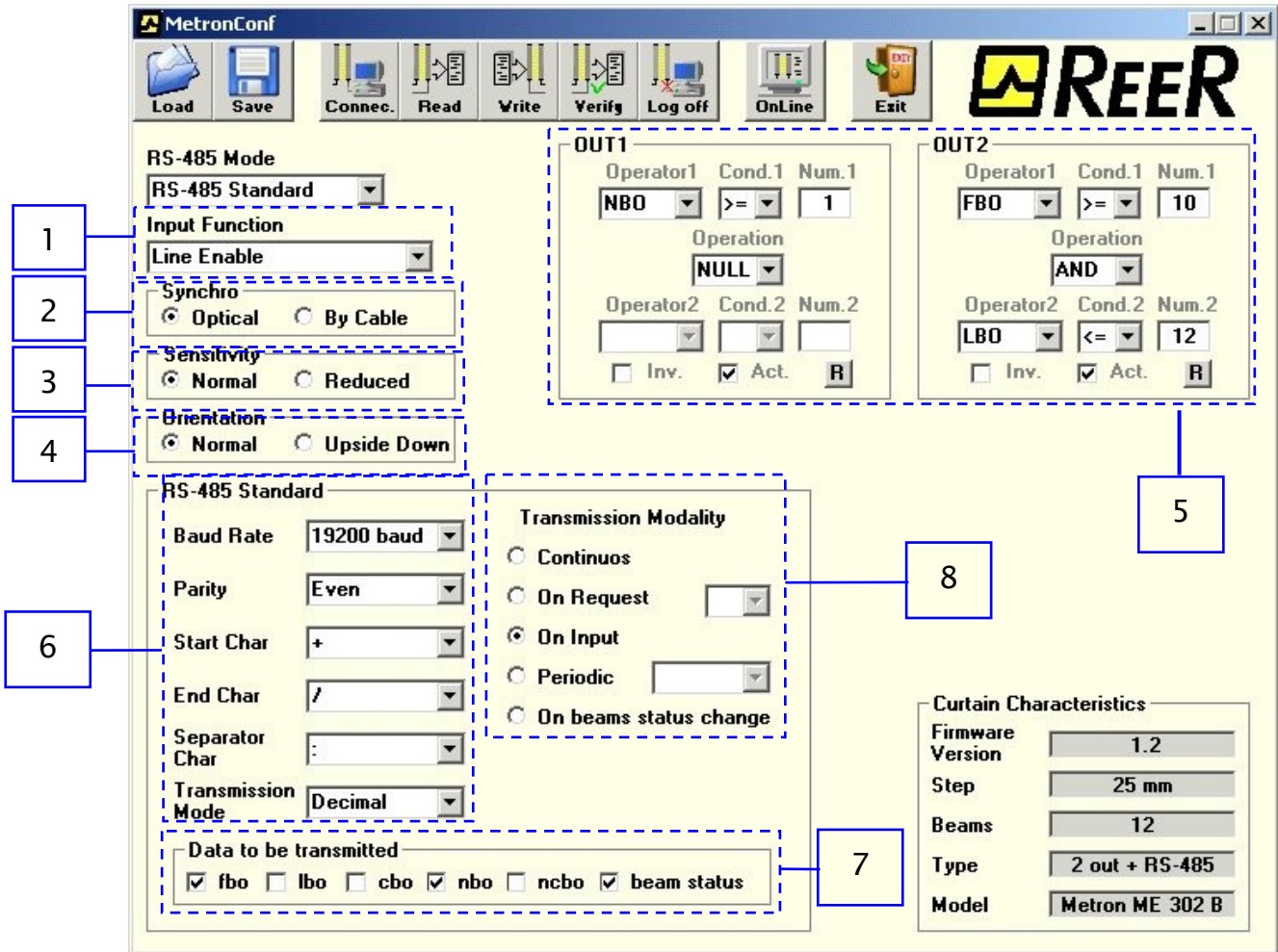

Figure 19 - RS-485 STANDARD

- 1 **Input Function Configuration:**
The input Function signal (INPUT-pin M) (minimum duration = 100ms, active high) on the light curtain can be programmed.
The various options are described in section "METRON 4 OUT CONFIGURATION".

If the transmission modality "UPON INPUT" is selected (in zone [8](#)), the following further functions will be activated:

NO FUNCTION	The outputs are activated when preset conditions occur and METRON sends a new data packet as soon as the previous one is finished
LINE ENABLE	Enables and disables the transmission of packets on the RS-485 line
LINE+OUTPUTS ENABLE	Enables and disables the required functions for the various outputs and transmission of packets on the RS-485 line
OUTPUTS STAND-BY	Repeats the process of sending the last data packet
LINE+OUTPUTS STAND-BY	Repeats the process of sending the last data packages and freezes the last situation present on the output
LINE START/STOP	Establishes the beginning and end of a measurement session. In the t_1 instant (Figure 18) METRON sends 3 data packets containing the maximum value detected during the measurement session (from t_0 to t_1) on the RS-485 line. The transmitted data will be that selected in zone 6
LINE+OUTPUTS START/STOP	Establishes the beginning and end of a measurement session. In the t_1 instant (Figure 18) METRON sends 3 data packets containing the maximum value detected during the measurement session (from t_0 to t_1) on the RS-485 line. The data transmitted will be that selected in zone 6 . The outputs activated in the instant t_1 (Figure 16) only if the preset conditions are met in this timeframe.

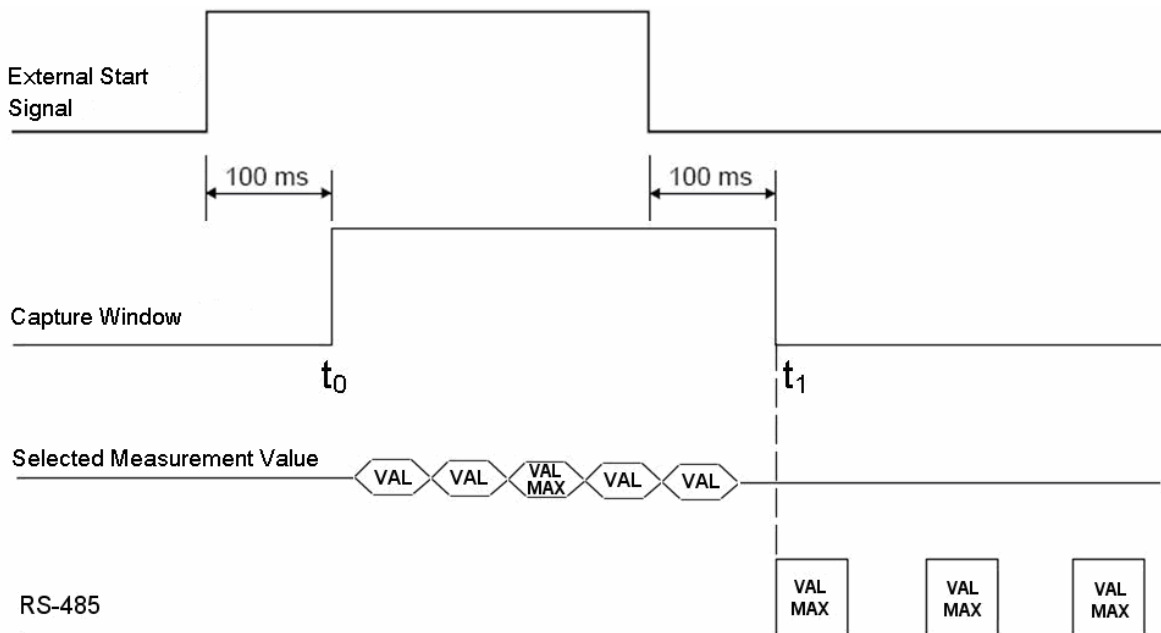

Figure 20 - START/STOP LINE

- [2](#) Synchronism Configuration: See page 19
- [3](#) Sensitivity Configuration: See page 19
- [4](#) Orientation Configuration: See page 20
- [5](#) Output Configuration: See page 20

There are 3 other configuration zones, which are described below :

6 Serial Line RS-485 configuration:

In addition to the standard parameters (Baud rate, parity bits), the user can also select the control characters as well as the data packet format, which METRON will send (decimal, hexadecimal, binary); specifically :

Decimal : 3 ASCII characters per data item	<i>Example 255 = "2","5","5" (0x32,0x35,0x35)</i>
Hexadecimal : 2ASCII characters per data item	<i>Example FF = "F","F" (0x46,0x46)</i>
Binary : 1 character in binary code	

7 Data transmitted on line: the information (data) transmitted via RS-485 serial line is as follows :

- **FBO** First beam obstructed
- **LBO** Last beam obstructed
- **CBO** Central beam obstructed
- **NBO** Number of beams obstructed
- **NCBO** Number of consecutive beams obstructed
- **BEAM STATUS** Status of each single beam represented in binary format

One or more of the above pieces of information can be selected. The following example illustrates how a data packet is composed with the configuration selected in Figure 17 and with a 30 beam light curtain:

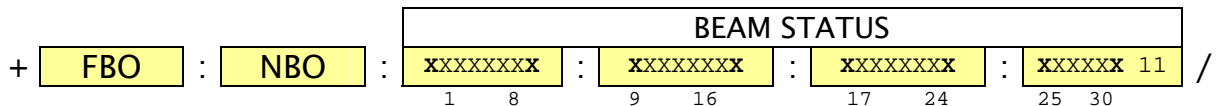

In this example, the fields **FBO** and **NBO** will respectively report the number of the first obstructed beam and the total number of occupied beams. As regards the **BEAM STATUS** fields, the characters "x" represent the status of each beam which may be:

- "0" = OBSTRUCTED
- "1" = FREE

8 Transmission Mode Configuration.

The information referred to in point 2 can be sent in the following modes:

- **CONTINUOUS**
METRON sends a new data packet as soon as the previous one has been sent.
- **UPON REQUEST**
METRON sends a data packet when it receives a user-selected character on the RS-485 line.
- **UPON INPUT**
METRON sends a data packet based on the chosen function for the INPUT signal (pin M).

- **PERIODIC**
METRON sends a new data packet based on the period selected by the user.
- **UPON BEAM CHANGE STATUS**
METRON sends a new packet as soon as the beam condition changes.

MODEL RS-485 FACTORY SETTINGS

INPUT FUNCTION	No function
SYNCHRONISM	Optical
ORIENTATION	Normal
SENSITIVITY	Normal
STATIC OUTPUT	OUT1 active
CONDITIONS FOR OUT1	NB0 >= 1 (presence control)
BAUD RATE	9600
PARITY	Par
START CHARACTER	!
END CHARACTER	CR
SEPARATOR CHARACTER	-
TRANSMISSION MODE	Hexadecimal
TRANSMITTED DATA ON LINE	Beam Status
TRANSMISSION MODALITY	Continuous

SENT DATA PACKET CONFIGURATION ON RS-485

As described above, the line is programmed, in terms of speed and parity, in accordance with the parameters chosen by the configurator. The configured transmission mode, the presence of a separator character and the measurements chosen in the generation of the report will produce messages with different formats as shown in the following figures in which, as an example, the following has been sent:

start char = "!" | data1 = 30 | data 2 = 15 | separ_char = "-" | end_char = "£"

start_char	dato ₁	dato ₂	dato ₃	dato ₄	dato ₅				dato _n	end_char
!"	00011110	00001111								£"

Figure 21: binary mode without separator

start_char	dato ₁	separator char	dato ₂	separator char	dato ₃				separator char	dato _n	end_char
!"	00011110	"-"	00001111								£"

Figure 22: binary mode with separator

start_char	High_dato ₁	Low_dato ₁	High_dato ₂	Low_dato ₂	High_dato ₃				Low_dato _n	end_char
!"	"1"	"E"	"0"	"F"						£"

Figure 23: hexadecimal mode without separator

start_char	High_dato ₁	Low_dato ₁	separator char	High_dato ₂	Low_dato ₂	separator char				Low_dato _n	end_char
!"	"1"	"E"	"-"	"0"	"F"						£"

Figure 24: hexadecimal mode with separator

start_char	dato ₁	dato ₂	dato ₃	dato ₄	dato ₅	dato ₆				dato _n	end_char
!"	"0"	"3"	"0"	"0"	"1"	"5"					£"

Figure 25: decimal mode without separator

start_char	dato ₁	dato ₂	dato ₃	separator char	dato ₄	dato ₅	dato ₆				dato _n	end_char
!"	"0"	"3"	"0"	"-"	"0"	"1"	"5"					£"

Figure 26: decimal mode with separator

Metron Multinode Serial Line RS-485 Configuration

Figure 25 shows the serial RS-485 configuration screen. Select the "RS-485 MULTI-NODE" option from the "RS-485 LINE MODE " drop-down menu .

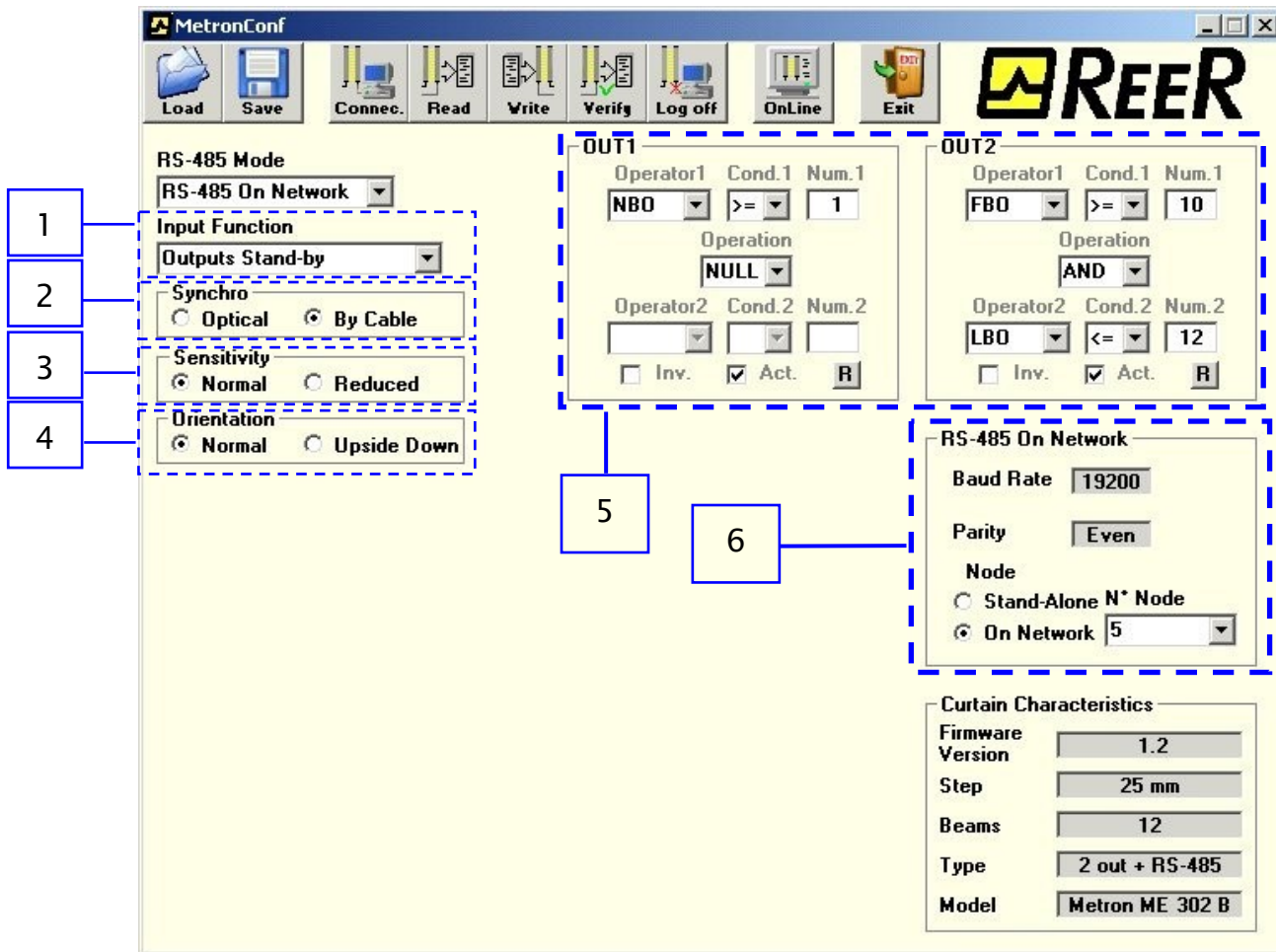

Figure 27

- 1 Input Function Configuration: See page 14
- 2 Synchronism Configuration: See page 19
- 3 Sensitivity Configuration: See page 19
- 4 Orientation Configuration: See page 20
- 5 Output Configuration: See page 20
- 6 RS-485 MULTINODE Configuration:

In this mode METRON acts as a "SLAVE" element in an RS-485 network and responds to the commands described in the REER Manual, Code 8540641 "METRON RS-485 Instruction Manual".

The Baud rate and the parity bit are set by REER.

METRON can be configured as an individual network element or, if there are several light curtains on the network, they can be assigned a node number.

➔ Maximum number of METRON per network = 8.

Configuration saving/opening

The  icon allows the user to save the configuration as soon as it is defined.

The  icon allows the user to recall a previously saved configuration.

Send Configuration to Light Curtain

Figure 26 shows the screen which allows the configuration selection to be sent from the PC to METRON. Select the  icon to activate it.

Wait for the "WRITING CORRECTLY EXECUTED" message to appear.

It is possible to verify that the configuration present on the light curtain is the same as that represented on MetronConf using the  icon.

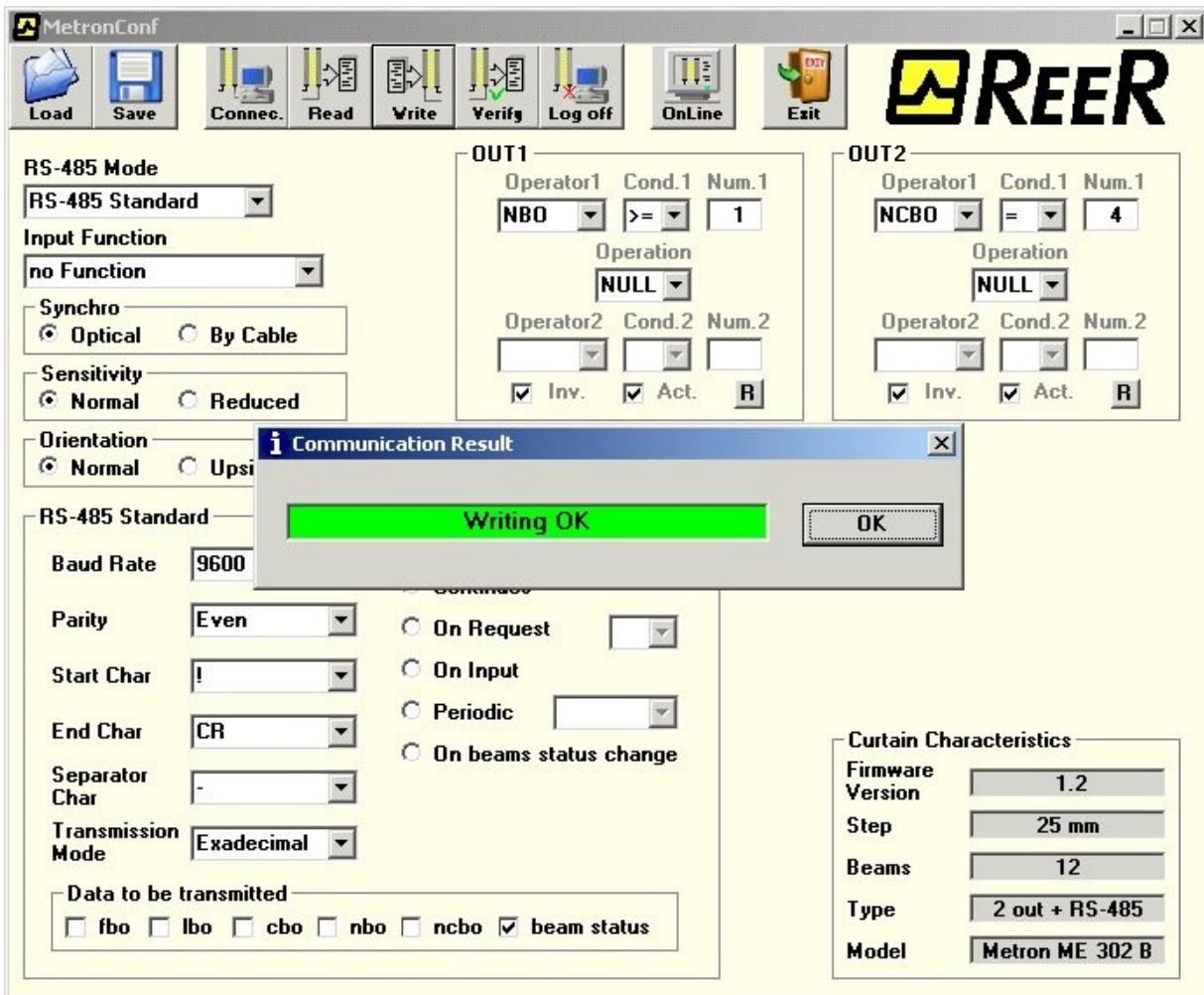



Figure 28 – Send configuration

Light Curtain Configuration Reading

Select the  icon to read the light curtain configuration; all the MetronConf interface fields will be automatically filled in.

Light Curtain Disconnection

Select the  icon to disconnect the light curtain. After approximately 10 seconds, the light curtain will become active using the configuration that was last sent.

Light Curtain Status Monitoring

By pressing the "ON LINE" key (Figure 12) or by selecting the  icon the programme makes a graphic interface available to the operator, which shows operation of the light curtain in real time. Figure 27 shows the interface with the light curtain connected in synchronism by cable and no detected object. A list of the supplied information is given below:

- 1 Receiver Display (in real time)
- 2 Synchronism (optical or via cable)
- 3 Sensitivity (this should be set to "reduced" for a distance TX-RX < 50cm)
- 4 Orientation (normal or upside-down)
- 5 Model and data of the connected light curtain
- 6 Graphic representation of METRON beams (in real time)
- 7 Synchronism via cable (does not appear if it is optical synchronism)
- 8 Measurements made (in real time)
- 9 Input Status (in real time)
- 10 Output Status (in real time)

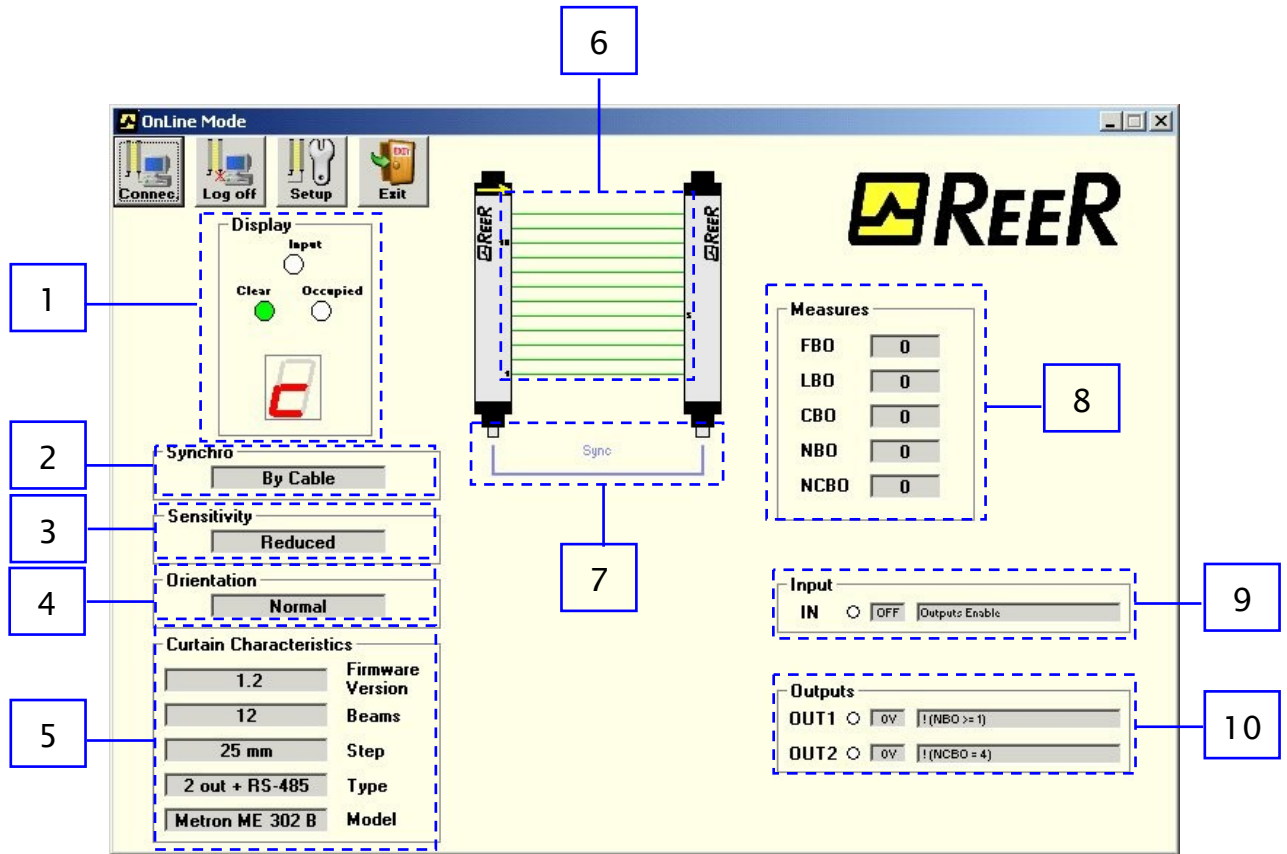

Figure 29 – Free Light Curtain (synchronism by cable)

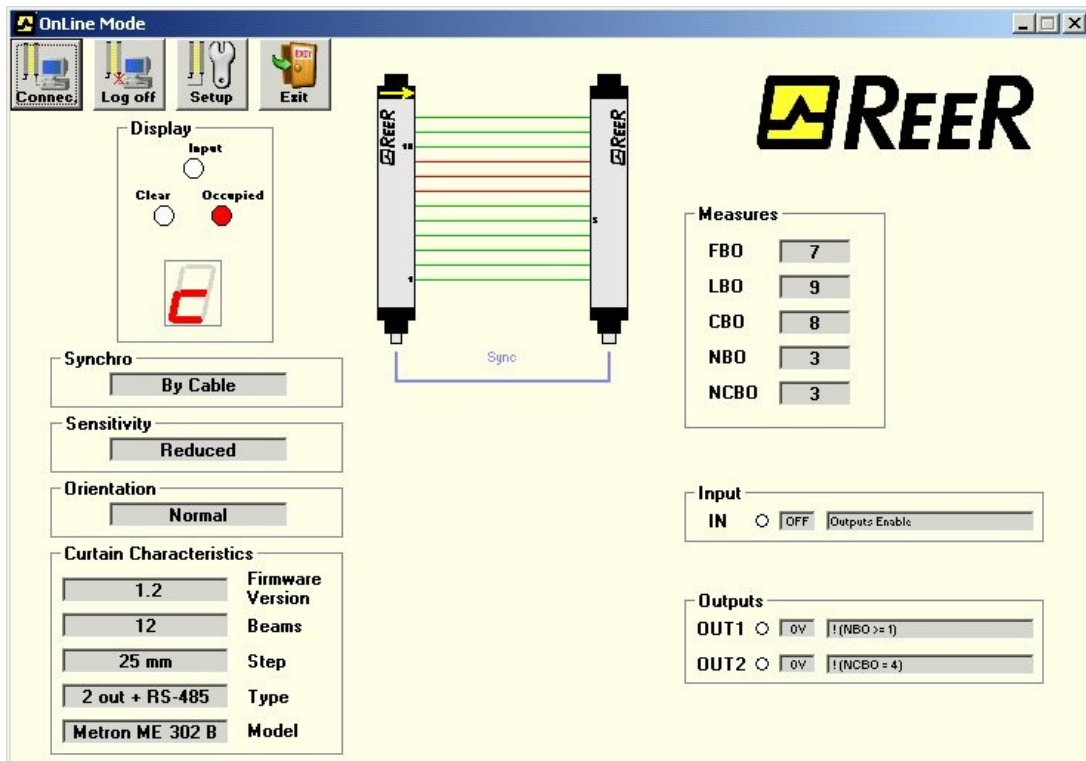

Figure 30 – Detected Object (synchronism by cable)

In this case the $FBO \geq 1$ condition which activates output 1 is met. This output is activated only when the input is enabled.

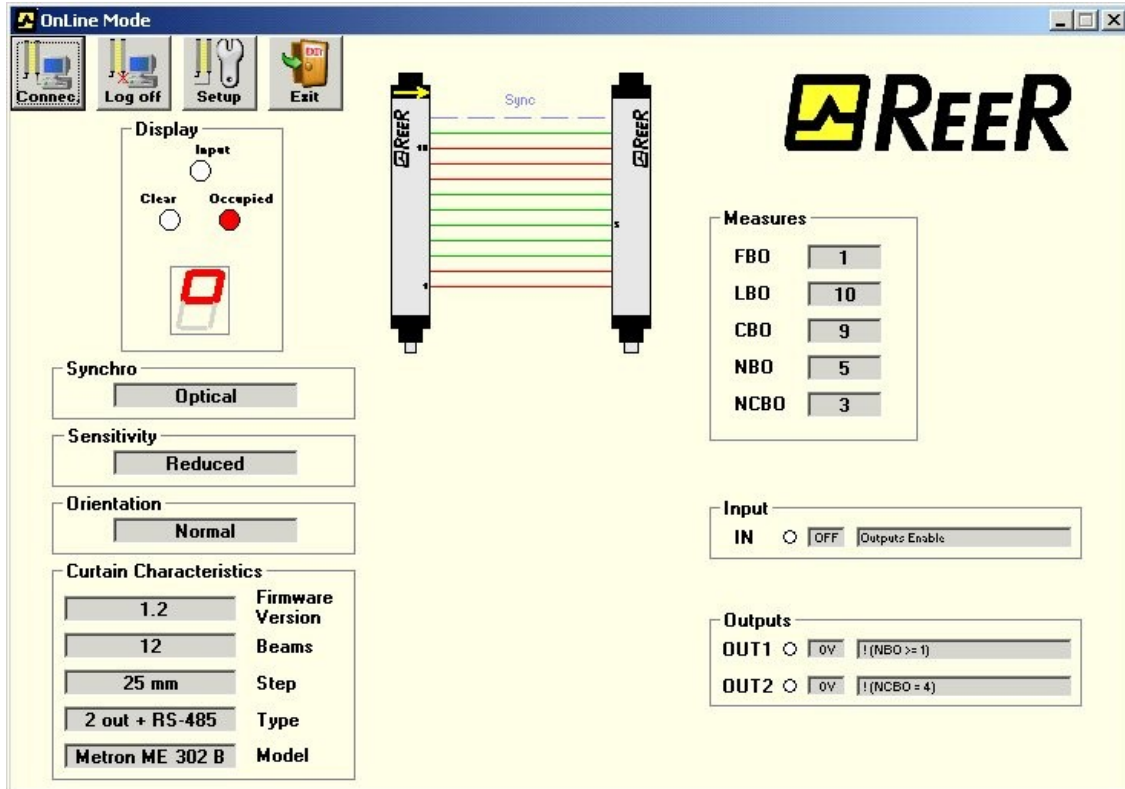

Figure 31 - 2 Detected Objects (Optical Synchronism)

In this case, the $FBO \geq 1$ condition which activates output 1 and $FBO \leq 6$ which activates output 2 is met. These outputs are activated only when input is enabled.

WARRANTY

REER guarantees that each newly manufactured METRON system, under conditions of normal use, is free from manufacturing defects and material defects for a period of 12 (twelve) months.

During such time, REER commits itself to eliminate any product damage, through the repair or replacement of faulty parts, completely free of charge regarding both materials and labour.

REER reserves the faculty to replace the entire faulty piece of equipment with another one of the same type or with equivalent features instead of performing repairs.

The validity of the warranty is subject to the following conditions:

- The notification of damage is forwarded by the user to REER within twelve months from the date of delivery of the product.
- The equipment and its components are in the conditions in which they were delivered by REER.
- The damages or malfunctioning was not originated directly or indirectly from:
 - Use for non-appropriate purposes;
 - Failure to comply with the usage norms;
 - Negligence, inexperience, inadequate maintenance;
 - Repairs, modifications, adaptations not performed by REER personnel, tampering, etc.;
 - Accidents or blows (even due to transportation or to acts of God);
 - Other causes independent from REER.

Repairs will be carried out by REER Laboratories, to which the material must be delivered or shipped: transportation expenses and eventual risk damages or material loss during shipping will be the Client's responsibility.

All replaced products and components will become REER's property.

REER does not recognise any other warranty or rights apart from those expressly described above; therefore, under no circumstances, can compensation requests for loss of income, suspension of activity or other factors or circumstances in any way correlated to the lack of functioning of the product or any of its parts be made.

The precise and integral compliance to all regulations, indications and prescriptions set forward in this brochure constitutes an essential requisite for the correct functioning of the safety light curtain.

Therefore, REER s.p.a., declines all responsibility arising from the failure to comply, even partially, with these indications.

Features subject to modification without forewarning. • Total or partial reproduction is forbidden without authorization from REER