

Safety. Detection. Control.

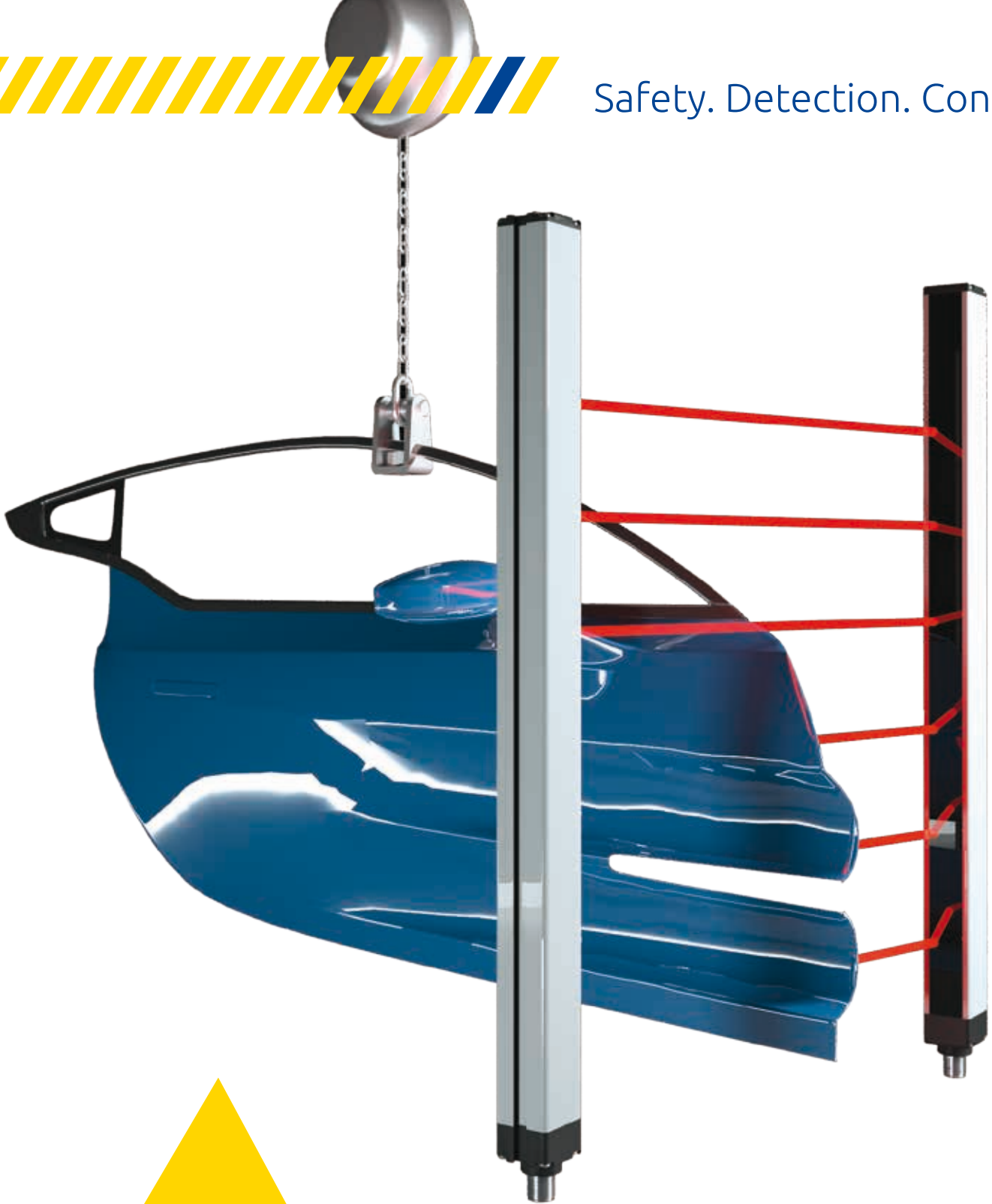

MICRON - METRON

Light Curtains for Measurement and Automation

Product catalogue

Issue 1

 **REER**

OVERVIEW

Aluminum casing
Anodized

-10 to +55° C
Operating temperature

Status indicating display
Including alignment aids

M12 connectors
Cables easy to source and replace

Measurement and automation
light curtains

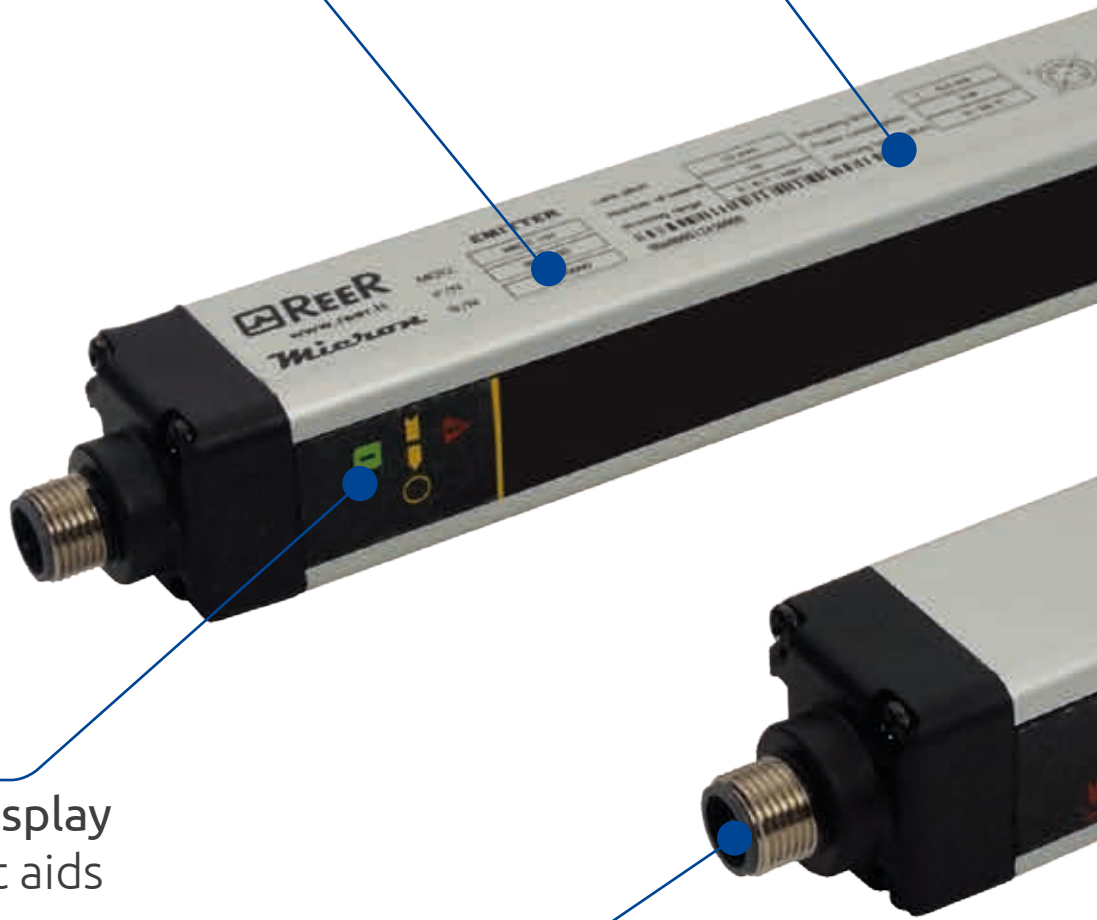

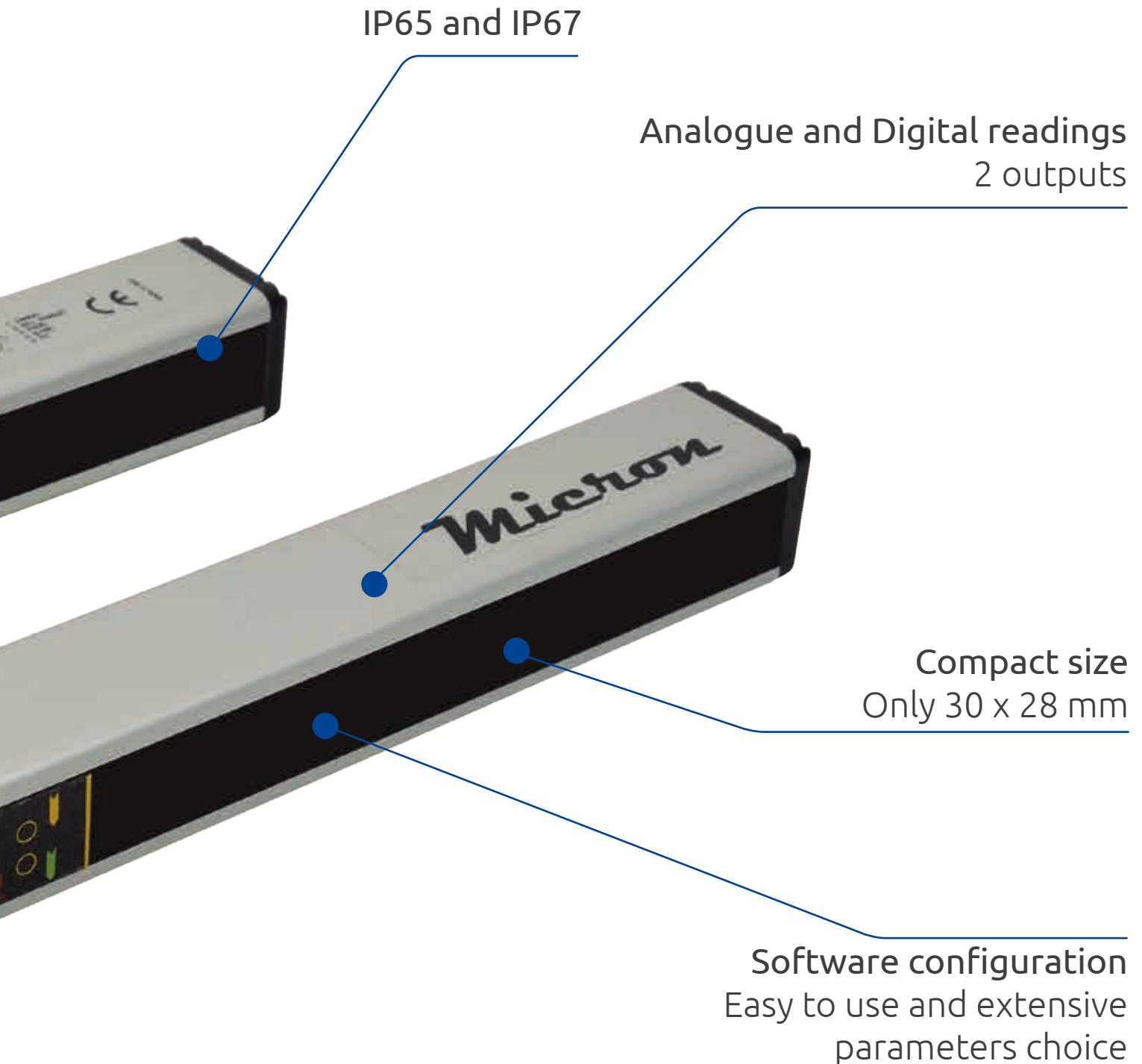





One simple product range to cover most of today's industrial and civil applications

OVERVIEW

Light curtains for industrial and civil applications where it is necessary to **detect**, **measure**, and **recognise** objects.

Depending on the number and position of the beams engaged by an object, Micron and Metron can provide real time information to a PLC or PC in order to:

-  Detect the presence or absence of objects
-  Perform a count
-  Detect a position
-  Detect a shape or a profile
-  Measure dimensions



TYPICAL APPLICATIONS



Measurement of the height of objects in transit on conveyor systems

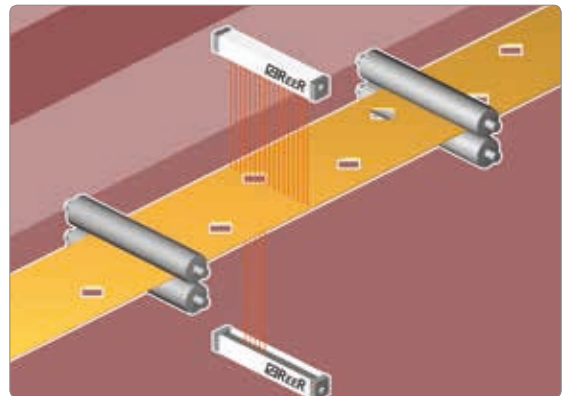

Quality control: verification of presence / absence / position of holes



Two-dimensional detection of objects in transit on conveyor systems with use of 2 light curtains. If necessary, the calculation of the volume can be made by means of a third horizontal light curtain, or considering the transit speed

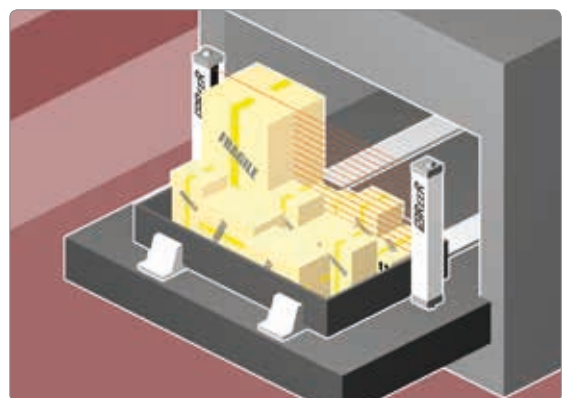

Automatic warehouses: detection of maximum height of the objects present in the boxes for efficient management of the machine's capacity

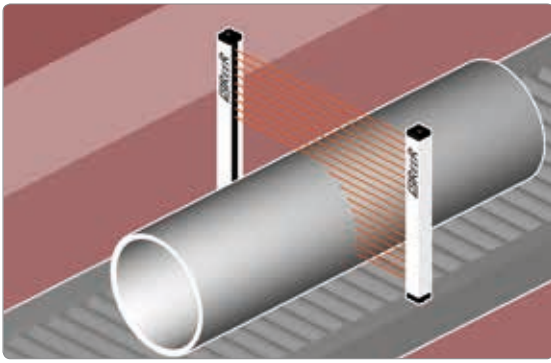

Measurement and identification of cylinders of various sizes

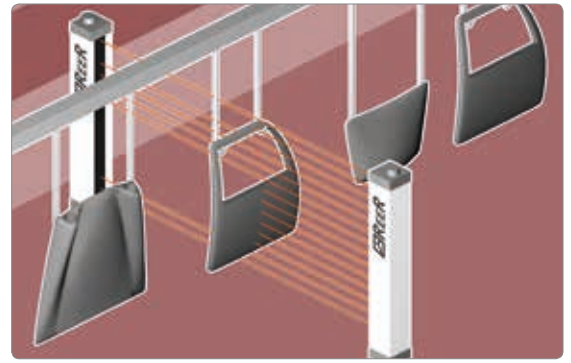

Detection of position and profile of pieces in automatic painting systems

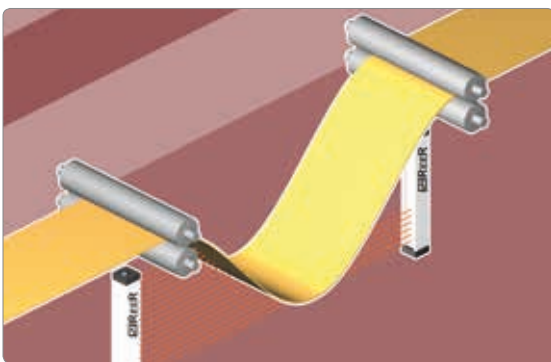

Loop control

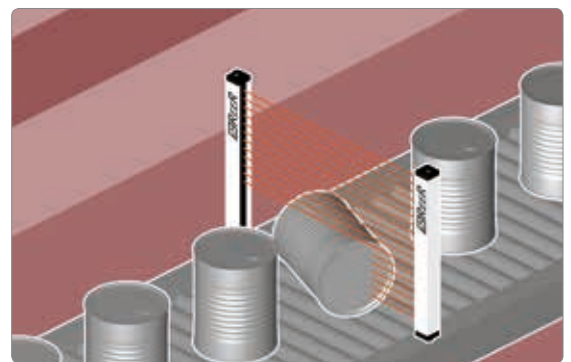

Quality control: verification of correct positioning of objects



Detection of overall dimensional limits of vehicles for vehicle handling in automatic parking garages

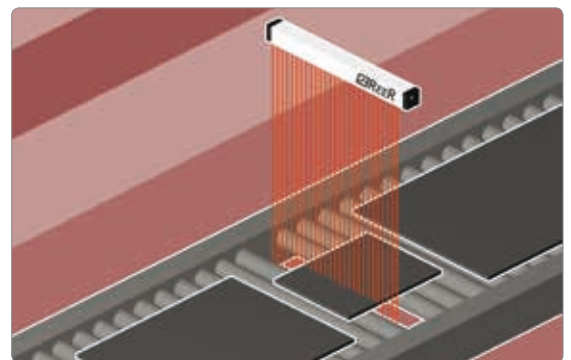

Measurement of the width and position of panels or sheets of material in transit on roller units or conveyor belts

SPECIAL APPLICATION

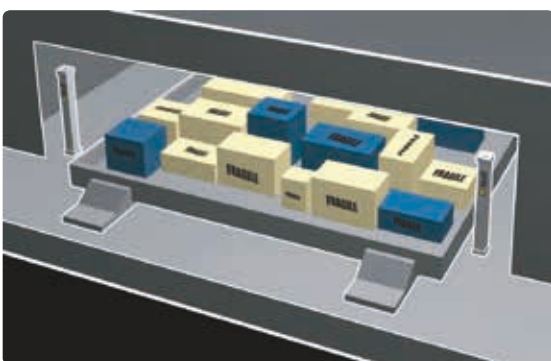

Automatic warehouses: detection of maximum height of the objects present in the boxes for efficient management of the machine's capacity

Automatic warehouse versions

Special Micron models with beams spacing: 25, 50, 75 mm

The special optics of these light curtains allow detection of small objects in quick motion.

Please contact ReeR for availability and models.

THE MICRON RANGE

MICRON A		MICRON B	MICRON C
Models MI AV	Models MI AC	Models MI B	Models MI C
Ideal for object measurement and detection of dimensional limits.		Ideal for dimensional measurement, detection of object profile and position.	Ideal for piece counting and detection of object presence/absence in the controlled field.
Two analog outputs (0 - 10 VDC) with programmable functions.	Two analog outputs (4 - 20 mA) with programmable functions.	RS 485 serial interface with programmable functions.	Two antivalent solid state outputs.
Two programmable digital outputs.	Two programmable digital outputs.	Two programmable digital outputs.	-
Solution providing simple measurement with easy interfacing.		Solution providing complete and detailed information on the status of each beam via the RS 485 serial line and, by means of the two solid state outputs, further on/off information related to the occurrence of the programmed conditions.	Solution providing simple on/off information related to the status of the controlled area.

NOTE: all Micron models can be provided in WT and WTH watertight enclosure (factory programmed only)

MICRON CERTIFICATION



0 ... +55 °C

Operating temperature -10 ... 55 °C



IP65 and IP67 protection rate

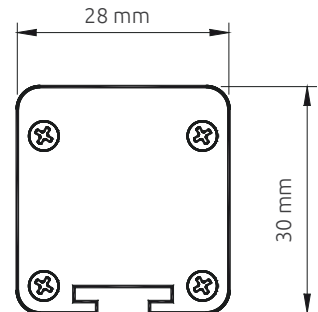

1:1 scale



Beam spacing	Analog output	Digital output
10 - 25 - 30 - 50 - 75	2	2

Models MI AV equipped with two analog outputs (0 - 10 VDC) with programmable functions and two programmable digital outputs.

Models MI AC equipped with two analog outputs (4 - 20 mA) with programmable functions and two programmable digital outputs.

Controlled heights: 150 ... 3000 mm.

Programming interface: USB interface on M5 4-pole connector. See [page 34](#).

Max. length connection cables between light curtain and interface: 100 (m).



MICRON A

TECHNICAL FEATURES

Max. range (m)	6 - models for automatic warehouses with beams spacing 25, 50, 75 mm
	10 - models with beam spacing 10, 30 mm
	18 - models with beam spacing 25, 50, 75 mm
Measurement time	(500 μs + 70 μs x n beams) x N Where N = scan cycles (1, 2, 3 selectable)
Scan cycles	1, 2, 3 selectable
Inputs (on receiver)	1 digital with programmable functions - 0 or 24V
MI AV (25, 50, 75 mm) Outputs	- 2 analog outputs (0-10 VDC) programmable - 2 solid state programmable digital outputs 0 or 24V (PNP 100 mA 24 VDC)
MI AC (25, 50, 75 mm) Outputs	- 2 analog outputs (4-20 mA) programmable - 2 solid state programmable digital outputs 0 or 24V (PNP 100 mA 24 VDC)
MI AV (10, 30 mm) Outputs	- 2 analog outputs (0-10 VDC) programmable - 2 solid state programmable digital outputs 0 or 24V (Push-Pull)
MI AC (10, 30 mm) Outputs	- 2 analog outputs (4-20 mA) programmable - 2 solid state programmable digital outputs 0 or 24V (Push-Pull)
Synchronisation between emitter and receiver	Optical or via cable, selectable
Electrical connections	Connector M12 5-pole (emitter)
	Connector M12 8-pole (receiver)
	M5 4-pole connector for programming interface
Status display	LEDs for operating status and light curtain self-diagnosis
Power supply (VDC)	24 ± 20%
Fastening	Back slot, or to the top and lower end with SFB E180 rotating brackets (optional)

CONNECTORS

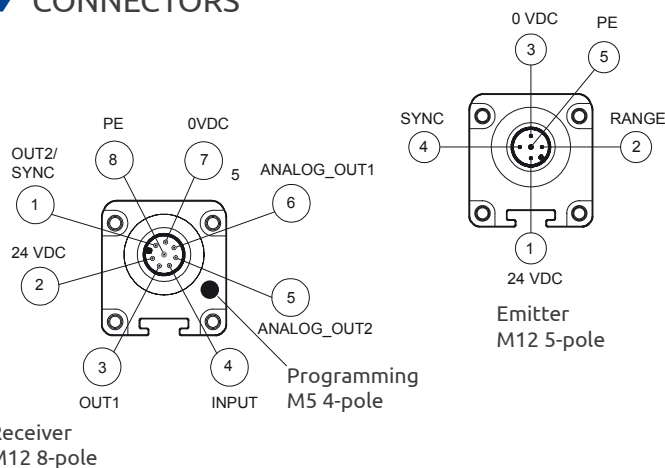

CABLES NEEDED

- Emitter M12 5-pole. See [page 30](#) (CD x, CD x SB, CD 9x, CDM 9 CDM 99)
- Receiver M12 8-pole. See [page 32](#) (C8D x, C8D x SB, C8D 9x, C8DM 9, C8DM 99, C8DM 11, C8DM 911)

ACCESSORIES

- Support columns. See [page 35](#)
- Laser alignment device. See [page 40](#)
- Vibration dampers. See [page 41](#)
- Brackets. See [page 38](#)

PART NUMBERS

Micron A beam spacing 10 mm

Beam spacing 10 mm	MI 151AV	MI 301AV	MI 451AV	MI 601AV	MI 751AV	MI 901AV	MI 1051AV	MI 1201AV	MI 1351AV	MI 1501AV	MI 1651AV	MI 1801AV
Ordering codes	1250020	1250021	1250022	1250023	1250024	1250025	1250026	1250027	1250028	1250029	1250030	1250031
Beam spacing 10 mm	MI 151AC	MI 301AC	MI 451AC	MI 601AC	MI 751AC	MI 901AC	MI 1051AC	MI 1201AC	MI 1351AC	MI 1501AC	MI 1651AC	MI 1801AC
Ordering codes	1250120	1250121	1250122	1250123	1250124	1250125	1250126	1250127	1250128	1250129	1250130	1250131
Controlled height (mm)	140	290	440	590	740	890	1040	1190	1340	1490	1640	1790
Number of beams	15	30	45	60	75	90	105	120	135	150	165	180
Overall height (mm)	213	363	513	763	813	963	1113	1263	1413	1563	1713	1863

Beam spacing 10 mm	MI 1951AV	MI 2101AV	MI 2251AV	MI 2401AV	MI 2551AV	MI 2701AV	MI 2851AV	MI 3001AV
Ordering codes	1250032	1250033	1250034	1250035	1250036	1250037	1250038	1250039
Beam spacing 10 mm	MI 1951AC	MI 2101AC	MI 2251AC	MI 2401AC	MI 2551AC	MI 2701AC	MI 2851AC	MI 3001AC
Ordering codes	1250132	1250133	1250134	1250135	1250136	1250137	1250138	1250139
Controlled height (mm)	1940	2090	2240	2390	2540	2690	2840	2990
Number of beams	195	210	225	240	255	270	285	300
Overall height (mm)	2013	2163	2313	2463	2613	2763	2913	3063

Micron A beam spacing 25 mm

Beam spacing 25 mm	MI 152AV	MI 302AV	MI 452AV	MI 602AV	MI 752AV	MI 902AV	MI 1052AV	MI 1202AV	MI 1352AV	MI 1502AV	MI 1652AV	MI 1802AV
Ordering codes	1250040	1250041	1250042	1250043	1250044	1250045	1250046	1250047	1250048	1250049	1250050	1250051
Beam spacing 25 mm	MI 152AC	MI 302AC	MI 452AC	MI 602AC	MI 752AC	MI 902AC	MI 1052AC	MI 1202AC	MI 1352AC	MI 1502AC	MI 1652AC	MI 1802AC
Ordering codes	1250140	1250141	1250142	1250143	1250144	1250145	1250146	1250147	1250148	1250149	1250150	1250151
Controlled height (mm)	125	275	425	575	725	875	1025	1175	1325	1475	1625	1775
Number of beams	6	12	18	24	30	36	42	48	54	60	66	72
Overall height (mm)	213	363	513	663	813	963	1113	1263	1413	1563	1713	1863

Beam spacing 25 mm	MI 1952AV	MI 2102AV	MI 2252AV	MI 2402AV	MI 2552AV	MI 2702AV	MI 2852AV	MI 3002AV
Ordering codes	1250052	1250053	1250054	1250055	1250056	1250057	1250058	1250059
Beam spacing 25 mm	MI 1952AC	MI 2102AC	MI 2252AC	MI 2402AC	MI 2552AC	MI 2702AC	MI 2852AC	MI 3002AC
Ordering codes	1250152	1250153	1250154	1250155	1250156	1250157	1250158	1250159
Controlled height (mm)	1925	2075	2225	2375	2525	2625	2825	2975
Number of beams	78	84	90	96	102	108	114	120
Overall height (mm)	2013	2163	2313	2463	2613	2763	2913	3063

Micron A beam spacing 30 mm

Beam spacing 30 mm	MI 153AV	MI 303AV	MI 453AV	MI 603AV	MI 753AV	MI 903AV	MI 1053AV	MI 1203AV	MI 1353AV	MI 1503AV	MI 1653AV	MI 1803AV
Ordering codes	1250060	1250061	1250062	1250063	1250064	1250065	1250066	1250067	1250068	1250069	1250070	1250071
Beam spacing 30 mm	MI 153AC	MI 303AC	MI 453AC	MI 603AC	MI 753AC	MI 903AC	MI 1053AC	MI 1203AC	MI 1353AC	MI 1503AC	MI 1653AC	MI 1803AC
Ordering codes	1250160	1250161	1250162	1250163	1250164	1250165	1250166	1250167	1250168	1250169	1250170	1250171
Controlled height (mm)	120	270	420	570	720	870	1020	1170	1320	1470	1620	1770
Number of beams	5	10	15	20	25	30	35	40	45	50	55	60
Overall height (mm)	213	363	513	663	813	963	1113	1263	1413	1563	1713	1863

Beam spacing 30 mm	MI 1953AV	MI 2103AV	MI 2253AV	MI 2403AV	MI 2553AV	MI 2703AV	MI 2853AV	MI 3003AV
Ordering codes	1250072	1250073	1250074	1250075	1250076	1250077	1250078	1250079
Beam spacing 30mm	MI 1953AC	MI 2103AC	MI 2253AC	MI 2403AC	MI 2553AC	MI 2703AC	MI 2853AC	MI 3003AC
Ordering codes	1250172	1250173	1250174	1250175	1250176	1250177	1250178	1250179
Controlled height (mm)	1920	2070	2220	2370	2520	2620	2820	2970
Number of beams	65	70	75	80	85	90	95	100
Overall height (mm)	2013	2163	2313	2463	2613	2763	2913	3063



Micron A beam spacing 50 mm

Beam spacing 50 mm	MI 155AV	MI 305AV	MI 455AV	MI 605AV	MI 755AV	MI 905AV	MI 1055AV	MI 1205AV	MI 1355AV	MI 1505AV	MI 1655AV	MI 1805AV
Ordering codes	1250080	1250081	1250082	1250083	1250084	1250085	1250086	1250087	1250088	1250089	1250090	1250091
Beam spacing 50 mm	MI 155AC	MI 305AC	MI 455AC	MI 605AC	MI 755AC	MI 905AC	MI 1055AC	MI 1205AC	MI 1355AC	MI 1505AC	MI 1655AC	MI 1805AC
Ordering codes	1250180	1250181	1250182	1250183	1250184	1250185	1250186	1250187	1250188	1250189	1250190	1250191
Controlled height (mm)	100	250	400	550	700	850	1000	1150	1300	1450	1600	1750
Number of beams	3	6	9	12	15	18	21	24	27	30	33	36
Overall height (mm)	213	363	513	663	813	963	1113	1263	1413	1563	1713	1863

Beam spacing 50 mm	MI 1955AV	MI 2105AV	MI 2255AV	MI 2405AV	MI 2555AV	MI 2705AV	MI 2855AV	MI 3005AV
Ordering codes	1250092	1250093	1250094	1250095	1250096	1250097	1250098	1250099
Beam spacing 50mm	MI 1955AC	MI 2105AC	MI 2255AC	MI 2405AC	MI 2555AC	MI 2705AC	MI 2855AC	MI 3005AC
Ordering codes	1250192	1250193	1250194	1250195	1250196	1250197	1250198	1250199
Controlled height (mm)	1900	2050	2200	2350	2500	2650	2800	2950
Number of beams	39	42	45	48	51	54	57	60
Overall height (mm)	2013	2163	2313	2463	2613	2763	2913	3063

Micron A beam spacing 75 mm

Beam spacing 75 mm	MI 157AV	MI 307AV	MI 457AV	MI 607AV	MI 757AV	MI 907AV	MI 1057AV	MI 1207AV	MI 1357AV	MI 1507AV	MI 1657AV	MI 1807AV
Ordering codes	1250100	1250101	1250102	1250103	1250104	1250105	1250106	1250107	1250108	1250109	1250110	1250111
Beam spacing 75 mm	MI 157AC	MI 307AC	MI 457AC	MI 607AC	MI 757AC	MI 907AC	MI 1057AC	MI 1207AC	MI 1357AC	MI 1507AC	MI 1657AC	MI 1807AC
Ordering codes	1250200	1250201	1250202	1250203	1250204	1250205	1250206	1250207	1250208	1250209	1250210	1250211
Controlled height (mm)	75	225	375	525	675	825	975	1125	1275	1425	1575	1725
Number of beams	2	4	6	8	10	12	14	16	18	20	22	24
Overall height (mm)	213	363	513	663	813	963	1113	1263	1413	1563	1713	1863

Beam spacing 75 mm	MI 1957AV	MI 2107AV	MI 2257AV	MI 2407AV	MI 2557AV	MI 2707AV	MI 2857AV	MI 3007AV
Ordering codes	1250112	1250113	1250114	1250115	1250116	1250117	1250118	1250119
Beam spacing 75mm	MI 1957AC	MI 2107AC	MI 2257AC	MI 2407AC	MI 2557AC	MI 2707AC	MI 2857AC	MI 3007AC
Ordering codes	1250212	1250213	1250214	1250215	1250216	1250217	1250218	1250219
Controlled height (mm)	1875	2025	2175	2325	2475	2625	2775	2925
Number of beams	26	28	30	32	34	36	38	40
Overall height (mm)	2013	2163	2313	2463	2613	2763	2913	3063



Beam spacing	Serial output	Digital output
10 - 25 - 30 - 50 - 75	RS 485 serial line	2

Models MI B equipped with an RS 485 serial interface with programmable functions and two programmable digital outputs.

Controlled heights: 150 ... 3000 mm.

Programming interface: USB interface on M5 4-pole connector.

Max. length connection cables between light curtain and interface: 100 (m).

Possibility of connection of up to 3 Micron B light curtains as nodes of an RS 485 serial line for simultaneous detection of multiple dimensions and complex measurements. In this application could be necessary shielded cables for the connections.

MICRON B

TECHNICAL FEATURES

Max. range (m)	6 - models for automatic warehouses with beams spacing 25, 50, 75 mm
	10 - models with beam spacing 10, 30 mm
	18 - models with beam spacing 25, 50, 75 mm
Measurement time	$(500 \mu s + 70 \mu s \times n \text{ beams}) \times N$ Where N = scan cycles (1,2,3 selectable)
Scan cycles	1, 2, 3 selectable
Inputs (on receiver)	1 digital with programmable functions - 0 or 24V
MI B (25, 50, 75 mm) Outputs	- RS 485 Serial line - 2 solid state programmable digital outputs 0 or 24V (PNP 100 mA 24 VDC)
MI B (10, 30 mm) Outputs	- RS 485 Serial line (up to 3 nodes) - 2 solid state programmable digital outputs 0 or 24V (Push-Pull)
Synchronisation between emitter and receiver	Optical or via cable, selectable
Electrical connections	Connector M12 5-pole (emitter)
	Connector M12 8-pole (receiver)
	M5 4-pole connector for programming interface
Status display	LEDs for operating status and light curtain self-diagnosis
Power supply (VDC)	24 ± 20%
Fastening	Back slot, or to the top and lower end with SFB E180 rotating brackets (optional)

CONNECTORS

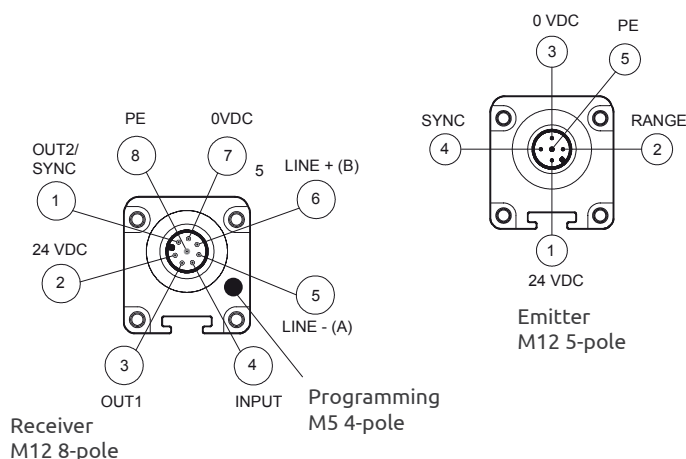

CABLES NEEDED

- Emitter M12 5-pole. See [page 30](#) (CD x, CD x SB, CD 9x, CDM 9 CDM 99)
- Receiver M12 8-pole. See [page 32](#) (C8D x, C8D x SB, C8D 9x, C8DM 9, C8DM 99, C8DM 11, C8DM 911)

ACCESSORIES

- Support columns. See [page 35](#)
- Laser alignment device. See [page 40](#)
- Vibration dumpers. See [page 41](#)
- Brackets. See [page 38](#)

PART NUMBERS

Micron B beam spacing 10 mm

Beam spacing 10 mm	MI 151B	MI 301B	MI 451B	MI 601B	MI 751B	MI 901B	MI 1051B	MI 1201B	MI 1351B	MI 1501B	MI 1651B	MI 1801B
Ordering codes	1250220	1250221	1250222	1250223	1250224	1250225	1250226	1250227	1250228	1250229	1250230	1250231
Controlled height (mm)	140	290	440	590	740	890	1040	1190	1340	1490	1640	1790
Number of beams	15	30	45	60	75	90	105	120	135	150	165	180
Overall height (mm)	213	363	513	763	813	963	1113	1263	1413	1563	1713	1863

Beam spacing 10 mm	MI 1951B	MI 2101B	MI 2251B	MI 2401B	MI 2551B	MI 2701B	MI 2851B	MI 3001B
Ordering codes	1250232	1250233	1250234	1250235	1250236	1250237	1250238	1250239
Controlled height (mm)	1940	2090	2240	2390	2540	2690	2840	2990
Number of beams	195	210	225	240	255	270	285	300
Overall height (mm)	2013	2163	2313	2463	2613	2763	2913	3063

Micron B beam spacing 25 mm

Beam spacing 25 mm	MI 152B	MI 302B	MI 452B	MI 602B	MI 752B	MI 902B	MI 1052B	MI 1202B	MI 1352B	MI 1502B	MI 1652B	MI 1802B
Ordering codes	1250240	1250241	1250242	1250243	1250244	1250245	1250246	1250247	1250248	1250249	1250250	1250251
Controlled height (mm)	125	275	425	575	725	875	1025	1175	1325	1475	1625	1775
Number of beams	6	12	18	24	30	36	42	48	54	60	66	72
Overall height (mm)	213	363	513	663	813	963	1113	1263	1413	1563	1713	1863

Beam spacing 25 mm	MI 1952B	MI 2102B	MI 2252B	MI 2402B	MI 2552B	MI 2702B	MI 2852B	MI 3002B
Ordering codes	1250252	1250253	1250254	1250255	1250256	1250257	1250258	1250259
Controlled height (mm)	1925	2075	2225	2375	2525	2625	2825	2975
Number of beams	78	84	90	96	102	108	114	120
Overall height (mm)	2013	2163	2313	2463	2613	2763	2913	3063

Micron B beam spacing 30 mm

Beam spacing 30 mm	MI 153B	MI 303B	MI 453B	MI 603B	MI 753B	MI 903B	MI 1053B	MI 1203B	MI 1353B	MI 1503B	MI 1653B	MI 1803B
Ordering codes	1250260	1250261	1250262	1250263	1250264	1250265	1250266	1250267	1250268	1250269	1250270	1250271
Controlled height (mm)	120	270	420	570	720	870	1020	1170	1320	1470	1620	1770
Number of beams	5	10	15	20	25	30	35	40	45	50	55	60
Overall height (mm)	213	363	513	663	813	963	1113	1263	1413	1563	1713	1863

Beam spacing 30 mm	MI 1953B	MI 2103B	MI 2253B	MI 2403B	MI 2553B	MI 2703B	MI 2853B	MI 3003B
Ordering codes	1250272	1250273	1250274	1250275	1250276	1250277	1250278	1250279
Controlled height (mm)	1920	2070	2220	2370	2520	2620	2820	2970
Number of beams	65	70	75	80	85	90	95	100
Overall height (mm)	2013	2163	2313	2463	2613	2763	2913	3063

Micron B beam spacing 50 mm

Beam spacing 50 mm	MI 155B	MI 305B	MI 455B	MI 605B	MI 755B	MI 905B	MI 1055B	MI 1205B	MI 1355B	MI 1505B	MI 1655B	MI 1805B
Ordering codes	1250280	1250281	1250282	1250283	1250284	1250285	1250286	1250287	1250288	1250289	1250290	1250291
Controlled height (mm)	100	250	400	550	700	850	1000	1150	1300	1450	1600	1750
Number of beams	3	6	9	12	15	18	21	24	27	30	33	36
Overall height (mm)	213	363	513	663	813	963	1113	1263	1413	1563	1713	1863

Beam spacing 50 mm	MI 1955B	MI 2105B	MI 2255B	MI 2405B	MI 2555B	MI 2705B	MI 2855B	MI 3005B
Ordering codes	1250292	1250293	1250294	1250295	125029	1250297	1250298	1250299
Controlled height (mm)	1900	2050	2200	2350	2500	2650	2800	2950
Number of beams	39	42	45	48	51	54	57	60
Overall height (mm)	2013	2163	2313	2463	2613	2763	2913	3063

Micron B beam spacing 75 mm

Beam spacing 75 mm	MI 157B	MI 307B	MI 457B	MI 607B	MI 757B	MI 907B	MI 1057B	MI 1207B	MI 1357B	MI 1507B	MI 1657B	MI 1807B
Ordering codes	1250300	1250301	1250302	1250303	1250304	1250305	1250306	1250307	1250308	1250309	1250310	1250311
Controlled height (mm)	75	225	375	525	675	825	975	1125	1275	1425	1575	1725
Number of beams	2	4	6	8	10	12	14	16	18	20	22	24
Overall height (mm)	213	363	513	663	813	963	1113	1263	1413	1563	1713	1863

Beam spacing 75 mm	MI 1957B	MI 2107B	MI 2257B	MI 2407B	MI 2557B	MI 2707B	MI 2857B	MI 3007B
Ordering codes	1250312	1250313	1250314	1250315	1250316	1250317	1250318	1250319
Controlled height (mm)	1875	2025	2175	2325	2475	2625	2775	2925
Number of beams	26	28	30	32	34	36	38	40
Overall height (mm)	2013	2163	2313	2463	2613	2763	2913	3063

MICRON C

TECHNICAL FEATURES

Max. range (m)	6 - models for automatic warehouses with beams spacing 25, 50, 75 mm 10 - models with beam spacing 10, 30 mm 18 - models with beam spacing 25, 50, 75 mm
Measurement time	(500 μs + 70 μs x n beams) x N Where N = scan cycles (1,2,3 selectable)
Scan cycles	1, 2, 3 selectable
Micron MI C (25, 50, 75 mm) outputs	2 - solid state 0 or 24V antivalent (PNP 100 mA at 24 VDC)
Micron MI C (10, 30 mm) outputs	2 - solid state 0 or 24V antivalent (Push-Pul). See the following image
Synchronisation between emitter and receiver	Optical or via cable, selectable
Electrical connections	2 M12 5-pole connectors (emitter and receiver)
Status display	LEDs for operating status and light curtain self-diagnosis
Power supply (VDC)	24 ± 20%
Fastening	Back slot, or to the top and lower end with SFB E180 rotating brackets (optional)



Beam spacing	Digital output
10 - 25 - 30 - 50 - 75	2

Models MI C equipped with two antivalent solid state outputs.

Controlled heights: 150 ... 3000 mm.

Max. length connection cables between light curtain and interface: 100 (m).

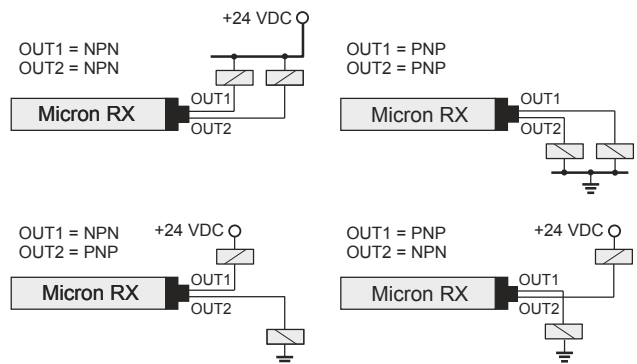

CONNECTORS

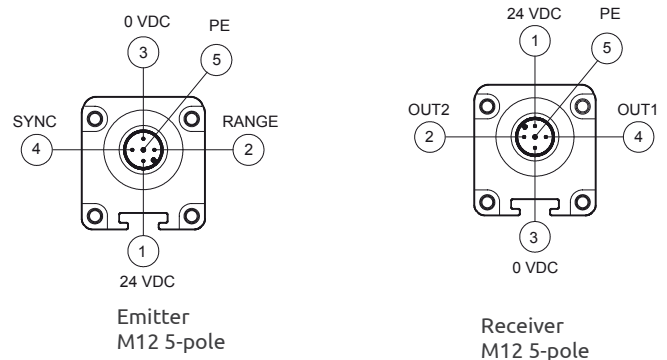

CABLES NEEDED

- Emitter M12 5-pole. See [page 30](#) (CD x, CD x SB, CD 9x, CDM 9 CDM 99)
- Receiver M12 5-pole. See [page 30](#) (CD x, CD x SB, CD 9x, CDM 9 CDM 99)

ACCESSORIES

- Support columns. See [page 35](#)
- Laser alignment device. See [page 40](#)
- Vibration dumpers. See [page 41](#)
- Brackets. See [page 38](#)

PART NUMBERS

Micron C beam spacing 10 mm

Beam spacing 10 mm	MI 151C	MI 301C	MI 451C	MI 601C	MI 751C	MI 901C	MI 1051C	MI 1201C	MI 1351C	MI 1501C	MI 1651C	MI 1801C
Ordering codes	1250320	1250321	1250322	1250323	1250324	1250325	1250326	1250327	1250328	1250329	1250330	1250331
Controlled height (mm)	140	290	440	590	740	890	1040	1190	1340	1490	1640	1790
Number of beams	15	30	45	60	75	90	105	120	135	150	165	180
Overall height (mm)	213	363	513	763	813	963	1113	1263	1413	1563	1713	1863

Beam spacing 10 mm	MI 1951C	MI 2101C	MI 2251C	MI 2401C	MI 2551C	MI 2701C	MI 2851C	MI 3001C
Ordering codes	1250332	1250333	1250334	1250335	1250336	1250337	1250338	1250339
Controlled height (mm)	1940	2090	2240	2390	2540	2690	2840	2990
Number of beams	195	210	225	240	255	270	285	300
Overall height (mm)	2013	2163	2313	2463	2613	2763	2913	3063

Micron C beam spacing 25 mm

Beam spacing 25 mm	MI 152C	MI 302C	MI 452C	MI 602C	MI 752C	MI 902C	MI 1052C	MI 1202C	MI 1352C	MI 1502C	MI 1652C	MI 1802C
Ordering codes	1250340	1250341	1250342	1250343	1250344	1250345	1250346	1250347	1250348	1250349	1250350	1250351
Controlled height (mm)	125	275	425	575	725	875	1025	1175	1325	1475	1625	1775
Number of beams	6	12	18	24	30	36	42	48	54	60	66	72
Overall height (mm)	213	363	513	663	813	963	1113	1263	1413	1563	1713	1863

Beam spacing 25 mm	MI 1952C	MI 2102C	MI 2252C	MI 2402C	MI 2552C	MI 2702C	MI 2852C	MI 3002C
Ordering codes	1250352	1250353	1250354	1250355	1250356	1250357	1250358	1250359
Controlled height (mm)	1925	2075	2225	2375	2525	2625	2825	2975
Number of beams	78	84	90	96	102	108	114	120
Overall height (mm)	2013	2163	2313	2463	2613	2763	2913	3063



Micron C beam spacing 25 mm

Beam spacing 30 mm	MI 153C	MI 303C	MI 453C	MI 603C	MI 753C	MI 903C	MI 1053C	MI 1203C	MI 1353C	MI 1503C	MI 1653C	MI 1803C
Ordering codes	1250360	1250361	1250362	1250363	1250364	1250365	1250366	1250367	1250368	1250369	1250370	1250371
Controlled height (mm)	120	270	420	570	720	870	1020	1170	1320	1470	1620	1770
Number of beams	5	10	15	20	25	30	35	40	45	50	55	60
Overall height (mm)	213	363	513	663	813	963	1113	1263	1413	1563	1713	1863

Beam spacing 30 mm	MI 1953C	MI 2103C	MI 2253C	MI 2403C	MI 2553C	MI 2703C	MI 2853C	MI 3003C
Ordering codes	1250372	1250373	1250374	1250375	1250376	1250377	1250378	1250379
Controlled height (mm)	1920	2070	2220	2370	2520	2620	2820	2970
Number of beams	65	70	75	80	85	90	95	100
Overall height (mm)	2013	2163	2313	2463	2613	2763	2913	3063

Micron C beam spacing 50 mm

Beam spacing 50 mm	MI 155C	MI 305C	MI 455C	MI 605C	MI 755C	MI 905C	MI 1055C	MI 1205C	MI 1355C	MI 1505C	MI 1655C	MI 1805C
Ordering codes	1250380	1250381	1250382	1250383	1250384	1250385	1250386	1250387	1250388	1250389	1250390	1250391
Controlled height (mm)	100	250	400	550	700	850	1000	1150	1300	1450	1600	1750
Number of beams	3	6	9	12	15	18	21	24	27	30	33	36
Overall height (mm)	213	363	513	663	813	963	1113	1263	1413	1563	1713	1863

Beam spacing 50 mm	MI 1955C	MI 2105C	MI 2255C	MI 2405C	MI 2555C	MI 2705C	MI 2855C	MI 3005C
Ordering codes	1250392	1250393	1250394	1250395	1250396	1250397	1250398	1250399
Controlled height (mm)	1900	2050	2200	2350	2500	2650	2800	2950
Number of beams	39	42	45	48	51	54	57	60
Overall height (mm)	2013	2163	2313	2463	2613	2763	2913	3063

Micron C beam spacing 75 mm

Beam spacing 75 mm	MI 157C	MI 307C	MI 457C	MI 607C	MI 757C	MI 907C	MI 1057C	MI 1207C	MI 1357C	MI 1507C	MI 1657C	MI 1807C
Ordering codes	1250400	1250401	1250402	1250403	1250404	1250405	1250406	1250407	1250408	1250409	1250410	1250411
Controlled height (mm)	75	225	375	525	675	825	975	1125	1275	1425	1575	1725
Number of beams	2	4	6	8	10	12	14	16	18	20	22	24
Overall height (mm)	213	363	513	663	813	963	1113	1263	1413	1563	1713	1863

Beam spacing 75 mm	MI 1957C	MI 2107C	MI 2257C	MI 2407C	MI 2557C	MI 2707C	MI 2857C	MI 3007C
Ordering codes	1250412	1250413	1250414	1250415	1250416	1250417	1250418	1250419
Controlled height (mm)	1875	2025	2175	2325	2475	2625	2775	2925
Number of beams	26	28	30	32	34	36	38	40
Overall height (mm)	2013	2163	2313	2463	2613	2763	2913	3063

THE “MICRONCONFIGURATOR” SOFTWARE

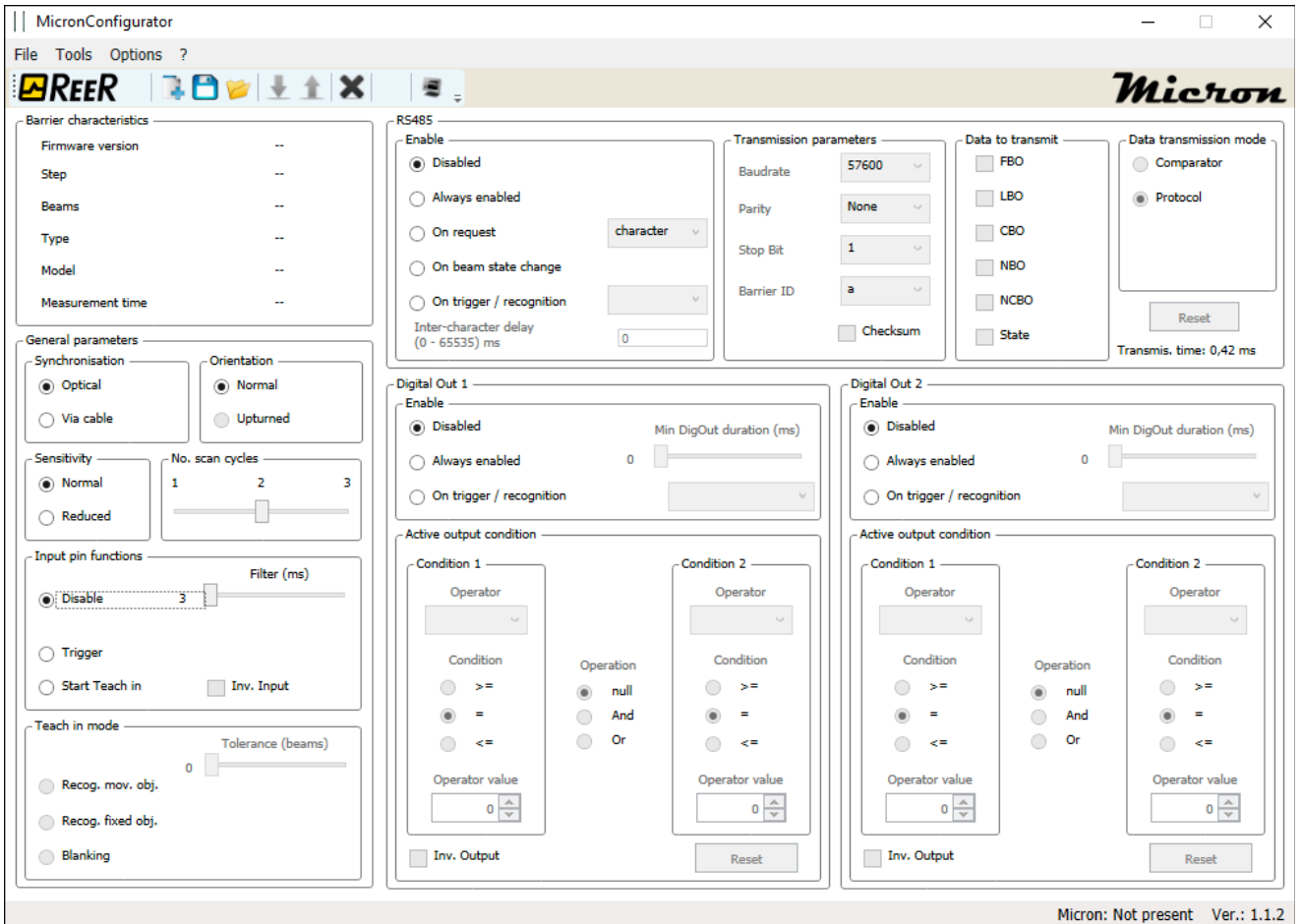

Software for PC, with graphic user interface, is supplied with each light curtain (Micron models A and B only).

Micron models A and B are provided with an M5 4-pole connector for parameter configuration and monitoring of the light curtain to be connected to a PC using the CSU M5 cable.

“MicronConfigurator” CHARACTERISTICS

Possibility for on-line display on PC screen during operation: (via USB) Status of each individual beam and solid state outputs

Configurable parameters Operating logic (conditions for output activation)
Parameters of the RS 485 serial line (transmission method, baud rate, parity, start-stop characters, binary, hex, ascii format, measurement time, etc.)

MECHANICAL DATA

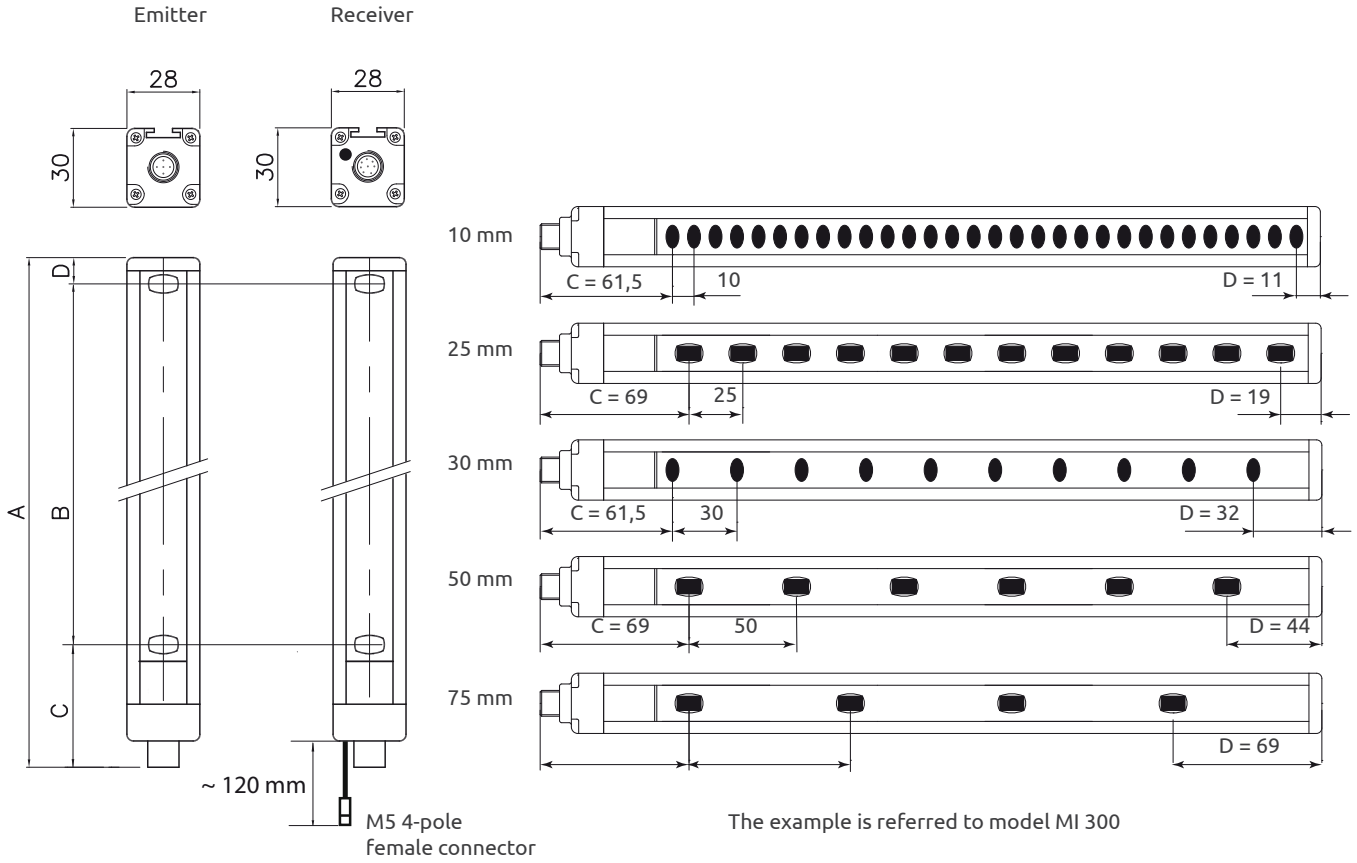

Model MI	150	300	450	600	750	900	1050	1200	1350	1500	1650
A	213	363	513	663	813	963	1113	1263	1413	1563	1713
B (controlled height)	B = (number of beams - 1) x beam spacing										
C (1 st beam position)	61,5 (for 10 and 30 mm models) - 69 (for 25, 50 and 75 mm models)										
Mounting	Complete set of 4 LE type brackets included in the package						Complete set of 6 LE type brackets included in the package				

Model MI	1800	1950	2100	2250	2400	2550	2700	2850	3000
A	1863	2013	2163	2313	2463	2613	2763	2913	3063
B (controlled height)	B = (number of beams - 1) x beam spacing								
C (1 st beam position)	61,5 (for 10 and 30 mm models) - 69 (for 25, 50 and 75 mm models)								
Mounting	Complete set of 6 LE type brackets included in the package								







BACKLIT TOP COVER WITH STATUS LED

Through-beam barrier type photocell with 5 beams.

With a compact metal housing and a polycarbonate protective front window it offers the right degree of robustness ideal also in the most demanding environments.

STATUS DISPLAY

	LED	State	Description
Emitter		ON	Beam emitted
		OFF	No beam
Receiver		ON	Controlled area is free
		ON	Break condition (controlled area is obstructed)



Operating temperature -30 ... 55 °C

-30 ... +55 °C



IP65 protection rate



M⁵

TECHNICAL FEATURES

Max. range (m)	0 ... 3
Measurement time (ms)	< 100
Power supply (VDC)	24 ± 20%
Power consumption at 24 VDC (W)	1
Number of beams	5
Beam spacing (mm)	10
Outputs on receiver	0 or 24V (PNP 100 mA 24 VDC) dark-on
Immunity to the ambient light (lx)	> 10000 (solar)
Emission angle	± 5°
Emission wavelength (nm)	940 modulated infrared
Electrical connections	Pigtail cable with M12 5-pole (emitter and receiver)
Fastening	Back slot
Dimension h x w x d (mm)	70 x 28 x 30

PART NUMBERS

Ordering code M⁵ (A coding): 1250910

Ordering code M⁵ (B coding): 1250911

Note: The use of different coding is recommended for the installation of two M⁵ sensors next to each other in order to avoid interference.

DIMENSIONS

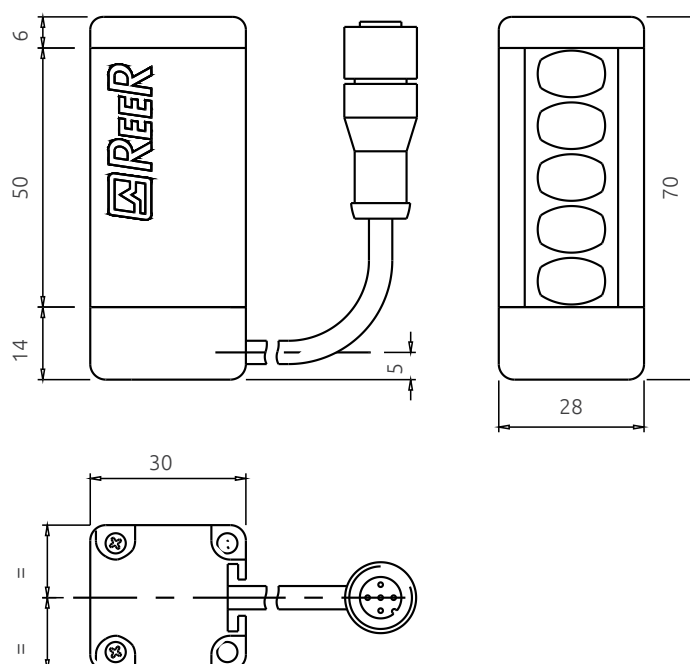

THE METRON RANGE

METRON A	METRON B	METRON C
Ideal for object recognition, quality control, detection of dimensional limits.	Ideal for dimensional measurement, detection of object profile and position.	Ideal for piece counting and detection of object presence/absence in the controlled field.
Four solid state outputs (0 - 24 VDC) with programmable functions.	RS 485 serial interface with programmable functions.	Two antivalent solid state outputs.
-	Two solid state outputs (0 - 24 VDC) with programmable functions.	-
Solution providing simple on/off information related to the occurrence of the programmed conditions.	Solution providing complete and detailed information on the status of each beam via the RS 485 serial line and, by means of the two solid state outputs, further on/off information related to the occurrence of the programmed conditions.	Solution providing simple on/off information related to the status of the controlled area.

METRON CERTIFICATION



Operating temperature 0 ... 55 °C

0 ... +55 °C



IP65 and IP67 protection rate

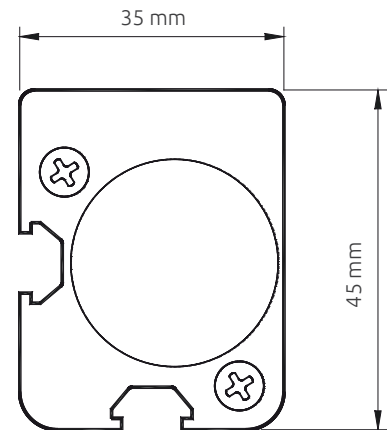

1:1 scale

METRON A

TECHNICAL FEATURES

	2 - models with beams spacing 5 mm
Max. range (m)	6 - models with beam spacing 25, 50, 75 mm 16 - models with beam spacing 10, 30 mm
Measurement time	(2.25 ms + 70 μs x n beams) x 2
Outputs	4 solid state programmable 0 or 24V (PNP 100 mA 24 VDC)
Inputs (on receiver)	1 digital with programmable functions - 0 or 24V
Synchronisation between emitter and receiver	Optical or via cable, selectable
Electrical connections	Connector M12 8-pole (emitter) Connector M16 12-pole (receiver) Connector M8 3-pole for RS 232 line programming (receiver)
Status display	7-segment display and LEDs for operating status and light curtain self-diagnosis
Power supply (VDC)	24 ± 20%
Fastening	Back slot, side slot, or to the top and lower end with swivel brackets



Models A equipped with 4 programmable solid state outputs.

Programming interface: RS 232 interface on M8 3-pole connector. See "CSL 3" on page 34

Controlled heights: 150 ... 2525 mm.

Max. length connection cables between light curtain and interface: 50 (m).

CABLES NEEDED

- Emitter M12 8-pole. See page 32 (C8D x, C8D x SB, C8D 9x, C8DM 9, C8DM 11)
- Receiver M16 12-pole. See page 33 (C12Dx)

ACCESSORIES

- Support columns. See page 36
- Laser alignment device. See page 40
- Vibration dumpers. See page 41
- Brackets. See page 39

CONNECTORS

Programming M8 3-pole

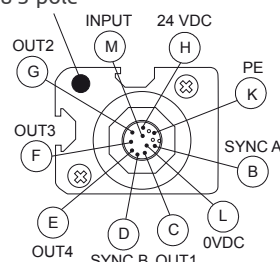

Receiver M16 12-pole

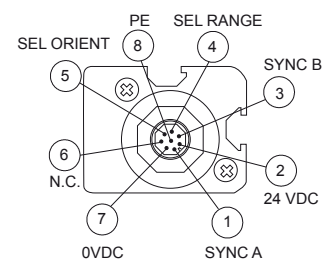

Emitter M12 8-pole



PART NUMBERS

Metron A beam spacing 5 mm

Beam spacing 5 mm	ME 150A	ME 300A	ME 450A	ME 600A	ME 750A	ME 900A	ME 1050A	ME 1200A
Ordering codes	1380500	1380501	1380502	1380503	1380504	1380505	1380506	1380507
Controlled height (mm)	145	295	445	595	745	895	1045	1195
Nr. beams	30	60	90	120	150	180	210	240
Overall height (mm)	261	411	561	711	861	1011	1161	1311

Metron A beam spacing 10 mm

Beam spacing 10 mm	ME 151A	ME 301A	ME 451A	ME 601A	ME 751A	ME 901A	ME 1051A	ME 1201A	ME 1351A	ME 1501A	ME 1651A	ME 1801A	ME 1951A	ME 2101A	ME 2251A	ME 2401A
Ordering codes	1380000	1380001	1380002	1380003	1380004	1380005	1380006	1380007	1380008	1380009	1380010	1380011	1380012	1380013	1380014	1380015
Controlled height (mm)	140	290	440	590	740	890	1040	1190	1340	1490	1640	1790	1940	2090	2240	2390
Nr. beams	15	30	45	60	75	90	105	120	135	150	165	180	195	210	225	240
Overall height (mm)	261	411	561	711	861	1011	1161	1311	1461	1611	1761	1911	2061	2211	2361	2511

Metron A beam spacing 25 mm

Beam spacing 25 mm	ME 302A	ME 452A	ME 602A	ME 752A	ME 902A	ME 1052A	ME 1202A	ME 1352A	ME 1502A	ME 1652A	ME 1802A	ME 1952A	ME 2102A	ME 2252A	ME 2402A	ME 2552A
Ordering codes	1380101	1380102	1380103	1380104	1380105	1380106	1380107	1380108	1380109	1380110	1380111	1380112	1380113	1380114	1380115	1380116
Controlled height (mm)	275	425	575	725	875	1025	1175	1325	1475	1625	1775	1925	2075	2225	2375	2525
Nr. beams	12	18	24	30	36	42	48	54	60	66	72	78	84	90	96	102
Overall height (mm)	411	561	711	861	1011	1161	1311	1461	1611	1761	1911	2061	2211	2361	2511	2661

Metron A beam spacing 30 mm

Beam spacing 30 mm	ME 303A	ME 453A	ME 603A	ME 753A	ME 903A	ME 1053A	ME 1203A	ME 1353A	ME 1503A	ME 1653A	ME 1803A	ME 1953A	ME 2103A	ME 2253A	ME 2403A	ME 2553A
Ordering codes	1380201	1380202	1380203	1380204	1380205	1380206	1380207	1380208	1380209	1380210	1380211	1380212	1380213	1380214	1380215	1380216
Controlled height (mm)	270	420	570	720	870	1020	1170	1320	1470	1620	1770	1920	2070	2220	2370	2520
Nr. beams	10	15	20	25	30	35	40	45	50	55	60	65	70	75	80	85
Overall height (mm)	411	561	711	861	1011	1161	1311	1461	1611	1761	1911	2061	2211	2361	2511	2661

Metron A beam spacing 50 mm

Beam spacing 50 mm	ME 455A	ME 605A	ME 755A	ME 905A	ME 1055A	ME 1205A	ME 1355A	ME 1505A	ME 1655A	ME 1805A	ME 1955A	ME 2105A	ME 2255A	ME 2405A	ME 2555A
Ordering codes	1380302	1380303	1380304	1380305	1380306	1380307	1380308	1380309	1380310	1380311	1380312	1380313	1380314	1380315	1380316
Controlled height (mm)	400	550	700	850	1000	1150	1300	1450	1600	1750	1900	2050	2200	2350	2500
Nr. beams	9	12	15	18	21	24	27	30	33	36	39	42	45	48	51
Overall height (mm)	561	711	861	1011	1161	1311	1461	1611	1761	1911	2061	2211	2361	2511	2661

Metron A beam spacing 75 mm

Beam spacing 75 mm	ME 607A	ME 757A	ME 907A	ME 1057A	ME 1207A	ME 1357A	ME 1507A	ME 1657A	ME 1807A	ME 1957A	ME 2107A	ME 2257A	ME 2407A	ME 2557A
Ordering codes	1380403	1380404	1380405	1380406	1380407	1380408	1380409	1380410	1380411	1380412	1380413	1380414	1380415	1380416
Controlled height (mm)	525	675	825	975	1125	1275	1425	1575	1725	1875	2025	2175	2325	2475
Nr. beams	8	10	12	14	16	18	20	22	24	26	28	30	32	34
Overall height (mm)	711	861	1011	1161	1311	1461	1611	1761	1911	2061	2211	2361	2511	2661

METRON B

TECHNICAL FEATURES

Max. range (m)	2 - models with beams spacing 5 mm 6 - models with beam spacing 25, 50, 75 mm 16 - models with beam spacing 10, 30 mm
Measurement time	(2.25 ms + 70 µs x n beams) x 2
Outputs	RS 485 Serial line (up to 8 nodes) 2 solid state programmable 0 or 24V (PNP 100 mA 24 VDC)
Inputs (on receiver)	1 digital with programmable functions - 0 or 24V
Synchronisation between emitter and receiver	Optical or via cable, selectable
Electrical connections	Connector M12 8-pole (emitter) Connector M16 12-pole (receiver) Connector M8 3-pole for RS 232 line programming (receiver)
Status display	7-segment display and LEDs for operating status and light curtain self-diagnosis
Power supply (VDC)	24 ± 20%
Fastening	Back slot, side slot, or to the top and lower end with swivel brackets

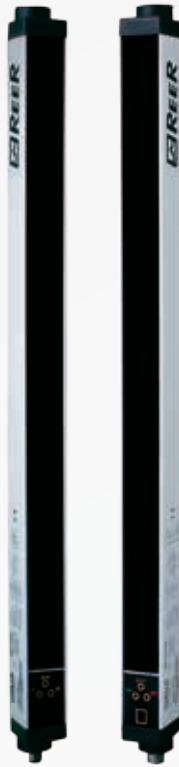

Beam spacing	Serial output	Digital output
5 - 10 - 25 - 30 - 50 - 75	RS 485 serial line	2

Models B equipped with 2 programmable solid state outputs and an RS 485 serial interface.

Programming interface: RS 232 interface on M8 3-pole connector.

Controlled heights: 150 ... 2525 mm.

Max. length connection cables between light curtain and interface: 50 (m).

CABLES NEEDED

- Emitter M12 8-pole. See [page 32](#) (C8D x, C8D x SB, C8D 9x, C8DM 9, C8DM 11)
- Receiver M16 12-pole. See [page 33](#) (C12Dx)

ACCESSORIES

- Support columns. See [page 36](#)
- Laser alignment device. See [page 40](#)
- Vibration dumpers. See [page 41](#)
- Brackets. See [page 39](#)

CONNECTORS

Programming M8 3-pole

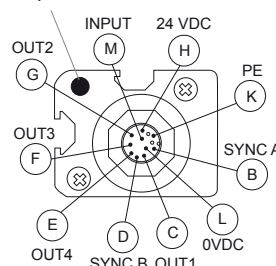

Receiver M16 12-pole

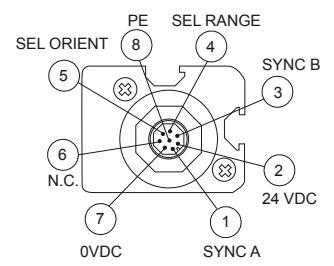

Emitter M12 8-pole



PART NUMBERS

Metron B beam spacing 5 mm

Beam spacing 5 mm	ME 150B	ME 300B	ME 450B	ME 600B	ME 750B	ME 900B	ME 1050B	ME 1200B
Ordering codes	1380520	1380521	1380522	1380523	1380524	1380525	1380526	1380527
Controlled height (mm)	145	295	445	595	745	895	1045	1195
Nr. beams	30	60	90	120	150	180	210	240
Overall height (mm)	261	411	561	711	861	1011	1161	1311

Metron B beam spacing 10 mm

Beam spacing 10 mm	ME 151B	ME 301B	ME 451B	ME 601B	ME 751B	ME 901B	ME 1051B	ME 1201B	ME 1351B	ME 1501B	ME 1651B	ME 1801B	ME 1951B	ME 2101B	ME 2251B	ME 2401B
Ordering codes	1380020	1380021	1380022	1380023	1380024	1380025	1380026	1380027	1380028	1380029	1380030	1380031	1380032	1380033	1380034	1380035
Controlled height (mm)	140	290	440	590	740	890	1040	1190	1340	1490	1640	1790	1940	2090	2240	2390
Nr. beams	15	30	45	60	75	90	105	120	135	150	165	180	195	210	225	240
Overall height (mm)	261	411	561	711	861	1011	1161	1311	1461	1611	1761	1911	2061	2211	2361	2511

Metron B beam spacing 25 mm

Beam spacing 25 mm	ME 302B	ME 452B	ME 602B	ME 752B	ME 902B	ME 1052B	ME 1202B	ME 1352B	ME 1502B	ME 1652B	ME 1802B	ME 1952B	ME 2102B	ME 2252B	ME 2402B	ME 2552B
Ordering codes	1380121	1380122	1380123	1380124	1380125	1380126	1380127	1380128	1380129	1380130	1380131	1380132	1380133	1380134	1380135	1380136
Controlled height (mm)	275	425	575	725	875	1025	1175	1325	1475	1625	1775	1925	2075	2225	2375	2525
Nr. beams	12	18	24	30	36	42	48	54	60	66	72	78	84	90	96	102
Overall height (mm)	411	561	711	861	1011	1161	1311	1461	1611	1761	1911	2061	2211	2361	2511	2661

Metron B beam spacing 30 mm

Beam spacing 30 mm	ME 303B	ME 453B	ME 603B	ME 753B	ME 903B	ME 1053B	ME 1203B	ME 1353B	ME 1503B	ME 1653B	ME 1803B	ME 1953B	ME 2103B	ME 2253B	ME 2403B	ME 2553B
Ordering codes	1380221	1380222	1380223	1380224	1380225	1380226	1380227	1380228	1380229	1380230	1380231	1380232	1380233	1380234	1380235	1380236
Controlled height (mm)	270	420	570	720	870	1020	1170	1320	1470	1620	1770	1920	2070	2220	2370	2520
Nr. beams	10	15	20	25	30	35	40	45	50	55	60	65	70	75	80	85
Overall height (mm)	411	561	711	861	1011	1161	1311	1461	1611	1761	1911	2061	2211	2361	2511	2661

Metron B beam spacing 50 mm

Beam spacing 50 mm	ME 455B	ME 605B	ME 755B	ME 905B	ME 1055B	ME 1205B	ME 1355B	ME 1505B	ME 1655B	ME 1805B	ME 1955B	ME 2105B	ME 2255B	ME 2405B	ME 2555B
Ordering codes	1380322	1380323	1380324	1380325	1380326	1380327	1380328	1380329	1380330	1380331	1380332	1380333	1380334	1380335	1380336
Controlled height (mm)	400	550	700	850	1000	1150	1300	1450	1600	1750	1900	2050	2200	2350	2500
Nr. beams	9	12	15	18	21	24	27	30	33	36	39	42	45	48	51
Overall height (mm)	561	711	861	1011	1161	1311	1461	1611	1761	1911	2061	2211	2361	2511	2661

Metron B beam spacing 75 mm

Beam spacing 75 mm	ME 607B	ME 757B	ME 907B	ME 1057B	ME 1207B	ME 1357B	ME 1507B	ME 1657B	ME 1807B	ME 1957B	ME 2107B	ME 2257B	ME 2407B	ME 2557B
Ordering codes	1380423	1380424	1380425	1380426	1380427	1380428	1380429	1380430	1380431	1380432	1380433	1380434	1380435	1380436
Controlled height (mm)	525	675	825	975	1125	1275	1425	1575	1725	1875	2025	2175	2325	2475
Nr. beams	8	10	12	14	16	18	20	22	24	26	28	30	32	34
Overall height (mm)	711	861	1011	1161	1311	1461	1611	1761	1911	2061	2211	2361	2511	2661

METRON C

TECHNICAL FEATURES

Max. range (m)	2 - models with beams spacing 5 mm 6 - models with beam spacing 25, 50, 75 mm 16 - models with beam spacing 10, 30 mm
Measurement time	(2.25 ms + 70 μs x n beams) x 2
Outputs	2 solid state 0 or 24V antivalent (PNP 100 mA 24 VDC)
Inputs (on receiver)	1 digital with programmable functions - 0 or 24V
Synchronisation between emitter and receiver	Optical or via cable, selectable
Electrical connections	Connector M12 5-pole (emitter and receiver)
Status display	7-segment display and LEDs for operating status and light curtain self-diagnosis
Power supply (VDC)	24 ± 20%
Fastening mode	Back slot, side slot, or to the top and lower end with swivel brackets



Beam spacing	Analog output
5 - 10 - 25 - 30 - 50 - 75	2

Models C equipped with 2 solid state antivalent outputs 0 or 24V without the need for programming.

Controlled heights: 150 ... 2525 mm.

Max. length connection cables between light curtain and interface: 50 (m).

CABLES NEEDED

- Emitter M12 5-pole.
See [page 30](#) (CD x, CD x SB, CD 9x, CDM 9 CDM 99)
- Receiver M12 5-pole.
See [page 30](#) (CD x, CD x SB, CD 9x, CDM 9 CDM 99)

ACCESSORIES

- Support columns. See [page 36](#)
- Laser alignment device. See [page 40](#)
- Vibration dumpers. See [page 41](#)
- Brackets. See [page 39](#)

CONNECTORS

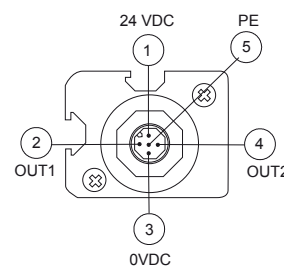

Receiver M12 5-pole

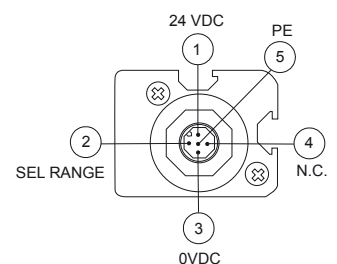

Emitter M12 8-pole



PART NUMBERS

Metron C beam spacing 5 mm

Beam spacing 5 mm	ME 150C	ME 300C	ME 450B	ME 600B	ME 750B	ME 900B	ME 1050B	ME 1200B
Ordering codes	1380540	1380541	1380542	1380543	1380544	1380545	1380546	1380547
Controlled height (mm)	145	295	445	595	745	895	1045	1195
Nr. beams	30	60	90	120	150	180	210	240
Overall height (mm)	261	411	561	711	861	1011	1161	1311

Metron C beam spacing 10 mm

Beam spacing 10 mm	ME 151C	ME 301C	ME 451C	ME 601C	ME 751C	ME 901C	ME 1051C	ME 1201C	ME 1351C	ME 1501C	ME 1651C	ME 1801C	ME 1951C	ME 2101C	ME 2251C	ME 2401C
Ordering codes	1380040	1380041	1380042	1380043	1380044	1380045	1380046	1380047	1380048	1380049	1380050	1380051	1380052	1380053	1380054	1380055
Controlled height (mm)	140	290	440	590	740	890	1040	1190	1340	1490	1640	1790	1940	2090	2240	2390
Nr. beams	15	30	45	60	75	90	105	120	135	150	165	180	195	210	225	240
Overall height (mm)	261	411	561	711	861	1011	1161	1311	1461	1611	1761	1911	2061	2211	2361	2511

Metron C beam spacing 25 mm

Beam spacing 25 mm	ME 302C	ME 452C	ME 602C	ME 752C	ME 902C	ME 1052C	ME 1202C	ME 1352C	ME 1502C	ME 1652C	ME 1802C	ME 1952C	ME 2102C	ME 2252C	ME 2402C	ME 2552C
Ordering codes	1380141	1380142	1380143	1380144	1380145	1380146	1380147	1380148	1380149	1380150	1380151	1380152	1380153	1380154	1380155	1380156
Controlled height (mm)	275	425	575	725	875	1025	1175	1325	1475	1625	1775	1925	2075	2225	2375	2525
Nr. beams	12	18	24	30	36	42	48	54	60	66	72	78	84	90	96	102
Overall height (mm)	411	561	711	861	1011	1161	1311	1461	1611	1761	1911	2061	2211	2361	2511	2661

Metron C beam spacing 30 mm

Beam spacing 30 mm	ME 303C	ME 453C	ME 603C	ME 753C	ME 903C	ME 1053C	ME 1203C	ME 1353C	ME 1503C	ME 1653C	ME 1803C	ME 1953C	ME 2103C	ME 2253C	ME 2403C	ME 2553C
Ordering codes	1380241	1380242	1380243	1380244	1380245	1380246	1380247	1380248	1380249	1380250	1380251	1380252	1380253	1380254	1380255	1380256
Controlled height (mm)	270	420	570	720	870	1020	1170	1320	1470	1620	1770	1920	2070	2220	2370	2520
Nr. beams	10	15	20	25	30	35	40	45	50	55	60	65	70	75	80	85
Overall height (mm)	411	561	711	861	1011	1161	1311	1461	1611	1761	1911	2061	2211	2361	2511	2661

Metron C beam spacing 50 mm

Beam spacing 50 mm	ME 455C	ME 605C	ME 755C	ME 905C	ME 1055C	ME 1205C	ME 1355C	ME 1505C	ME 1655C	ME 1805C	ME 1955C	ME 2105C	ME 2255C	ME 2405C	ME 2555C
Ordering codes	1380342	1380343	1380344	1380345	1380346	1380347	1380348	1380349	1380350	1380351	1380352	1380353	1380354	1380355	1380356
Controlled height (mm)	400	550	700	850	1000	1150	1300	1450	1600	1750	1900	2050	2200	2350	2500
Nr. beams	9	12	15	18	21	24	27	30	33	36	39	42	45	48	51
Overall height (mm)	561	711	861	1011	1161	1311	1461	1611	1761	1911	2061	2211	2361	2511	2661

Metron C beam spacing 75 mm

Beam spacing 75 mm	ME 607C	ME 757C	ME 907C	ME 1057C	ME 1207C	ME 1357C	ME 1507C	ME 1657C	ME 1807C	ME 1957C	ME 2107C	ME 2257C	ME 2407C	ME 2557C
Ordering codes	1380443	1380444	1380445	1380446	1380447	1380448	1380449	1380450	1380451	1380452	1380453	1380454	1380455	1380456
Controlled height (mm)	525	675	825	975	1125	1275	1425	1575	1725	1875	2025	2175	2325	2475
Nr. beams	8	10	12	14	16	18	20	22	24	26	28	30	32	34
Overall height (mm)	711	861	1011	1161	1311	1461	1611	1761	1911	2061	2211	2361	2511	2661

THE "METRONCONF" CONFIGURATION SOFTWARE

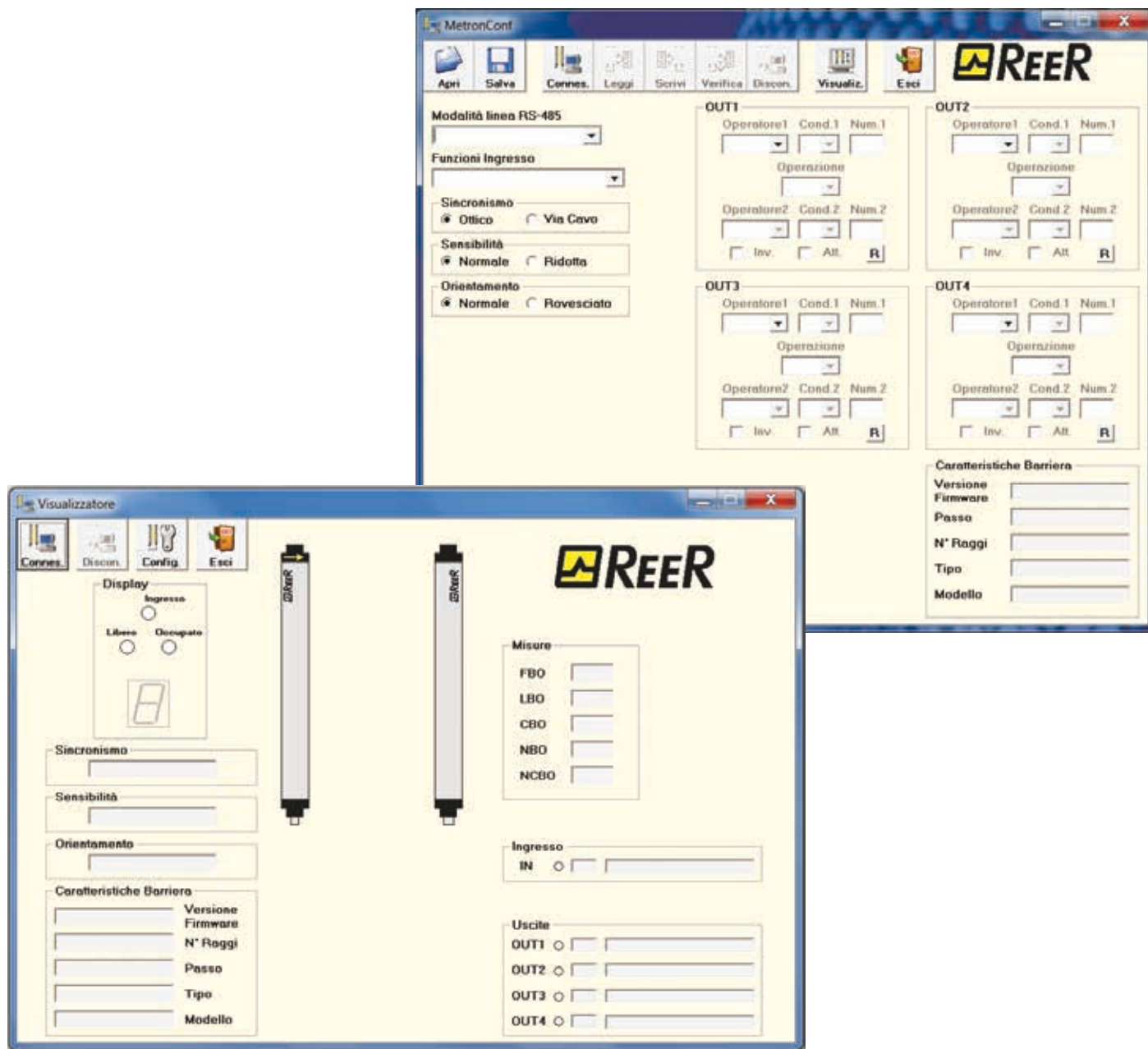

Software for PC, with graphic user interface, is supplied with each light curtain (Metron models A and B only).

Metron models A and B are provided with an M8 3-pole connector for parameter configuration and monitoring of the light curtain, to be connected to a PC using the CSL 3 cable.

“MetroConf” CHARACTERISTICS

Possibility for on-line display on PC screen during operation: (via RS 232) Status of each individual beam and solid state outputs

Configurable parameters Operating logic (conditions for output activation)
 Parameters of the RS 485 serial line (transmission method, baud rate, parity, start-stop characters, binary, hex, ascii format, measurement time, etc.)

MECHANICAL DATA

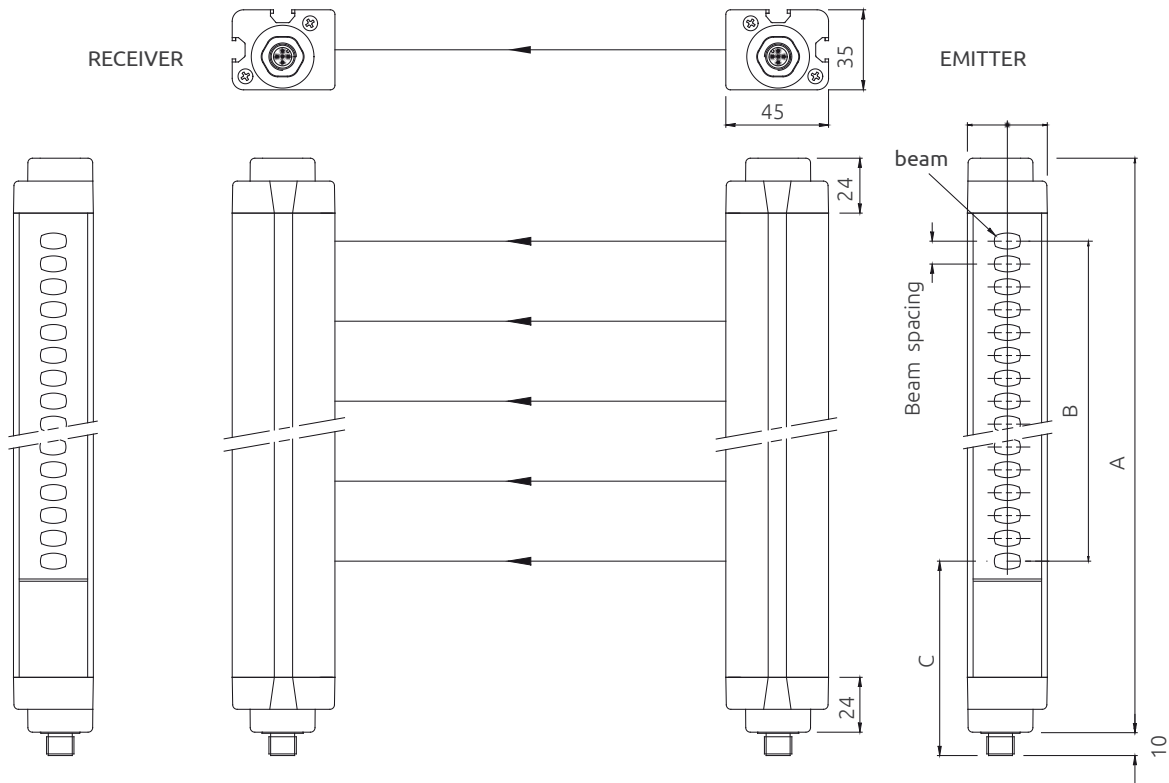

Model ME	150	300	450	600	750	900	1050	1200
A	251	401	551	701	851	1001	1151	1301
B (controlled height)	B = (number of beams -1) x beam spacing (with cable synchronisation) B = (number of beams -2) x beam spacing (with optical synchronisation)*							
C (1 st beam position)	85 (for 10, 30 models) - 93 (for 25, 50, 75 models)							
Mounting	Complete set of 4 LS type brackets included in the package							

Model ME	1350	1500	1650	1800	1950	2100	2250	2400	2550
A	1451	1601	1751	1901	2051	2201	2351	2501	2651
B (controlled height)	B = (number of beams -1) x beam spacing (with cable synchronisation) B = (number of beams -2) x beam spacing (with optical synchronisation)*								
C (1 st beam position)	85 (for 10 - 30 models) - 93 (for 25-50-75 models)								
Mounting	Complete set of 6 LS type brackets included in the package								

* In the case of optical synchronism, the beam adjacent to the upper end cap cannot be used for measurement, as it constitutes the synchronism beam

FIELD BUS INTERFACES



These modules allow the connection of the Micron measurement light curtains with the following industrial field bus:

- MI - BP - Profibus DP
- MI - BD - DeviceNET
- MI - BC - CANopen
- MI - BEC - EtherCAT
- MI - BEI - Ethernet IP
- MI - BEP - PROFINET
- MI - BMR - ModBus RTU
- MI - BEM - ModBus TCP/IP
- MI - BU - USB Universal Serial Bus

MI - Bs

FIELD BUS INTERFACES FOR MICRON

Expansion unit for connect Micron light curtain to the most common industrial Field-bus systems for diagnostics and data communication.

APPLICATION EXAMPLE

In all applications where it is required a communication between the Micron light curtains and PLC control.

TECHNICAL FEATURES

Ports	RS 485 serial ports for I/O BUS expansion USB port for configuration
Connection to Micron	Via Micron cable
Power supply (VDC)	24 ± 20%
Operating temperature (°C)	-10 ... 55 °C
Storage temperature (°C)	- 20 ... 85 °C
Protection rating	IP20 for housing IP2X for terminal block
Fastening	DIN rail fastening according to EN 50022-35 standard
Connection	Removable terminal blocks, screw contacts
Dimensions h x w x d (mm)	99 x 22,5 x 114

PART NUMBERS

1250500	MI - BP Profibus DP interface module
1250501	MI - BD DeviceNet interface module
1250502	MI - BC CANopen interface module
1250503	M - BEI Ethernet IP interface module
1250504	MI - BEC EtherCAT interface module
1250505	MI BEP PROFINET interface module
1250506	MI - BU Universal Serial Bus interface module
1250507	MI - BMR ModBus RTU interface module
1250508	MI - BEM ModBus TCP/IP interface module

CABLES

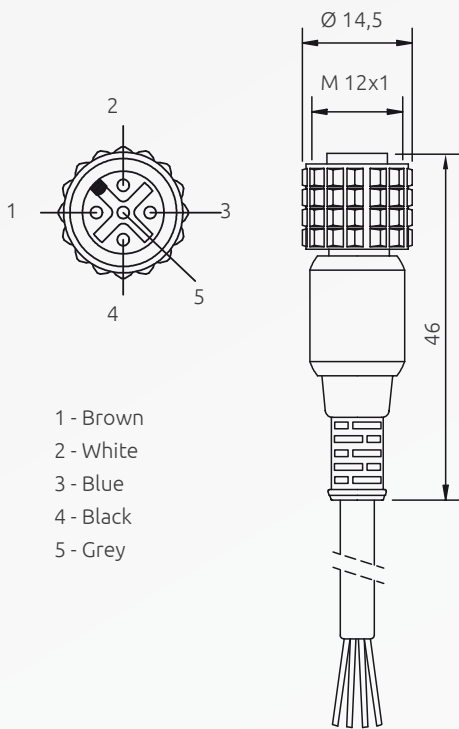

CD x

M12 STRAIGHT CONNECTOR 5-POLE

Models	Codes	Description
CD 5	1330950	M12 straight connector 5-pole, pre-wired cable 5 m
CD 10	1330956	M12 straight connector 5-pole, pre-wired cable 10 m
CD 15	1330952	M12 straight connector 5-pole, pre-wired cable 15 m
CD 20	1330957	M12 straight connector 5-pole, pre-wired cable 20 m
CD 25	1330949	M12 straight connector 5-pole, pre-wired cable 25 m
CD 50	1330965	M12 straight connector 5-pole, pre-wired cable 50 m

CD x SB

M12 STRAIGHT CONNECTOR 5-POLE, SHIELDED

Models	Codes	Description
CD 5 SB	1330850	M12 straight connector 5-pole, pre-wired shielded cable 5 m
CD 10 SB	1330856	M12 straight connector 5-pole, pre-wired shielded cable 10 m
CD 15 SB	1330852	M12 straight connector 5-pole, pre-wired shielded cable 15 m

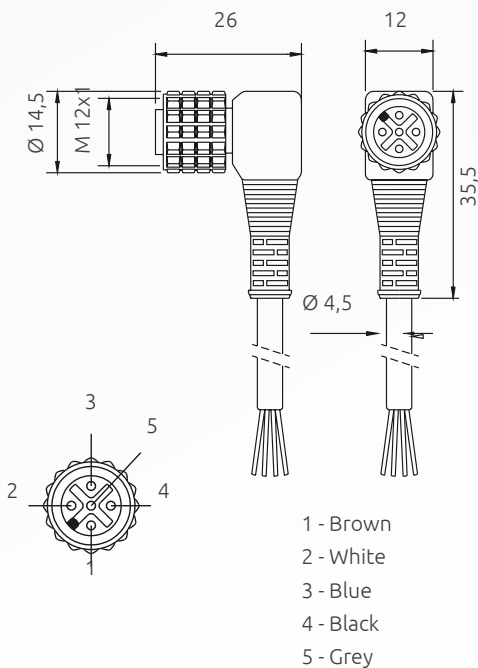

CD 9x

M12 90° ANGLE CONNECTOR 5-POLE

Models	Codes	Description
CD 95	1330951	M12 90° angle connector 5-pole, pre-wired cable 5 m
CD 910	1330958	M12 90° angle connector 5-pole, pre-wired cable 10 m
CD 915	1330953	M12 90° angle connector 5-pole, pre-wired cable 15 m

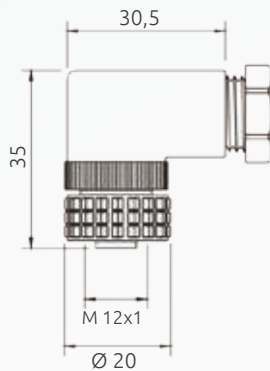
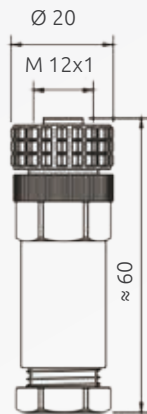

CDM 9

M12 STRAIGHT CONNECTOR 5-POLE SCREW TERMINAL, PG9 CABLE GLAND

Model	Code	Description
CDM 9	1330954	M12 straight connector 5-pole with screw terminal, PG9 cable gland

C8DM 9

M12 STRAIGHT CONNECTOR 8-POLE SCREW TERMINAL, PG9 CABLE GLAND

Model	Code	Description
C8DM 9	1330986	M12 straight connector 8-pole with screw terminal, PG9 cable gland

CDM 99

M12 STRAIGHT CONNECTOR 5-POLE SCREW TERMINAL, PG9 CABLE GLAND

Model	Code	Description
CDM 99	1330955	M12 90° angle connector 5-pole with screw terminal, PG9 cable gland

C8DM 99

M12 STRAIGHT CONNECTOR 8-POLE SCREW TERMINAL, PG9 CABLE GLAND

Model	Code	Description
C8DM 99	1330987	M12 90° angle connector 8-pole with screw terminal, PG9 cable gland

CABLES

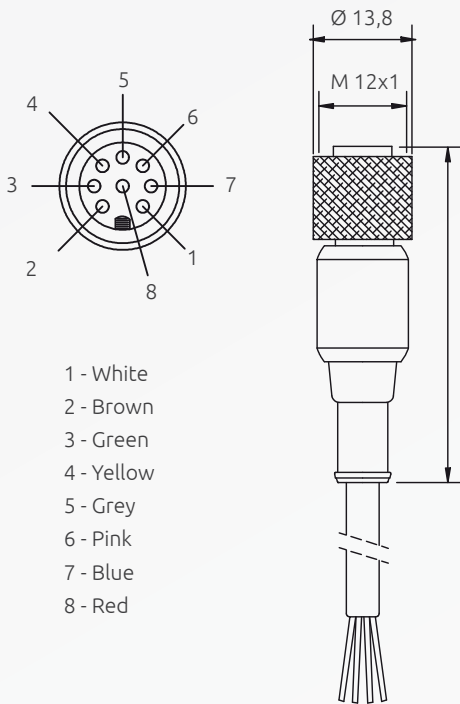

C8D x

M12 STRAIGHT CONNECTOR 8-POLE

Models	Codes	Description
C8D 5	1330980	M12 straight connector 8-pole, pre-wired cable 5 m
C8D 10	1330981	M12 straight connector 8-pole, pre-wired cable 10 m
C8D 15	1330982	M12 straight connector 8-pole, pre-wired cable 15 m
C8D 25	1330967	M12 straight connector 8-pole, pre-wired cable 25 m
C8D 40	1330966	M12 straight connector 8-pole, pre-wired cable 40 m

C8D x SB

M12 STRAIGHT CONNECTOR 8-POLE, SHIELDED

Model	Codes	Description
C8D 5 SB	1330880	M12 straight connector 8-pole, pre-wired shielded cable 5 m
C8D 10 SB	1330881	M12 straight connector 8-pole, pre-wired shielded cable 10 m
C8D 15 SB	1330882	M12 straight connector 8-pole, pre-wired shielded cable 15 m

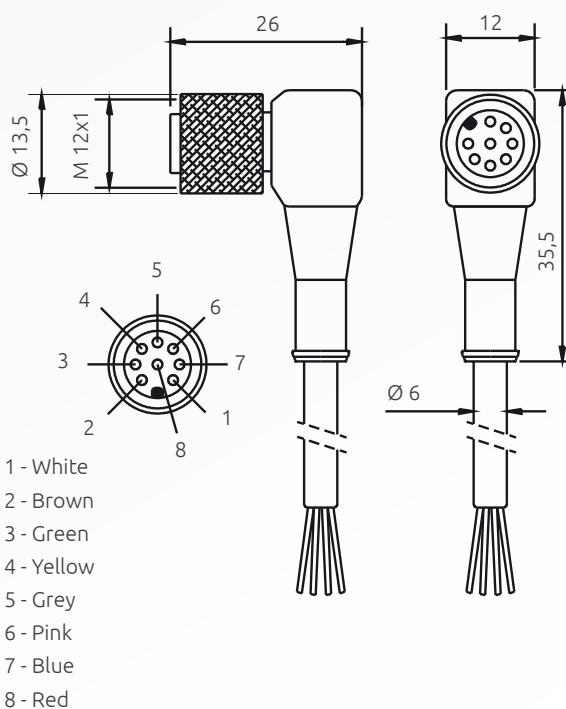

C8D 9x

M12 90° ANGLE CONNECTOR 8-POLE

Models	Codes	Description
C8D 95	1330983	M12 90° angle connector 8-pole, pre-wired cable 5 m
C8D 910	1330984	M12 90° angle connector 8-pole, pre-wired cable 10 m
C8D 915	1330985	M12 90° angle connector 8-pole, pre-wired cable 15 m

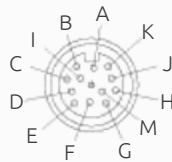
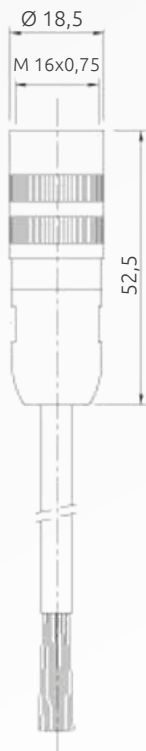
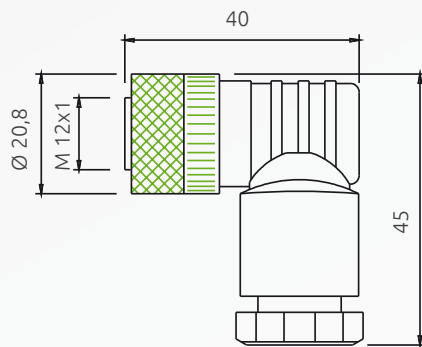
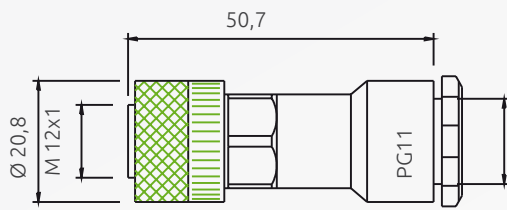

A - Grey-pink
 B - Green
 C - White
 D - Grey
 E - Pink
 F - Red
 G - Black
 H - Violet
 J - Red-Blue
 L - Brown
 M - Blue
 K - Yellow

C8DM 11

M12 STRAIGHT CONNECTOR 8-POLE SCREW TERMINAL, PG9/11 CABLE GLAND

Model	Code	Description
C8DM 11	1330978	M12 straight connector 8-pole with screw terminal, PG9/11 cable gland

C8DM 911

M12 90° ANGLE CONNECTOR 8-POLE SCREW TERMINAL, PG9/11 CABLE GLAND

Model	Code	Description
C8DM 911	1330979	M12 90° angle connector 8-pole with screw terminal, PG9/11 cable gland

C12D x

M16 STRAIGHT CONNECTOR 12-POLE

Model	Codes	Description
C12D 3	1330917	M16 straight connector 12-pole, pre-wired cable 3 m
C12D 5	1330918	M16 straight connector 12-pole, pre-wired cable 5 m
C12D 3	1330919	M16 straight connector 12-pole, pre-wired cable 10 m
C12D 15	1330924	M16 straight connector 12-pole, pre-wired cable 15 m
C12D 25	1330916	M16 straight connector 12-pole, pre-wired cable 25 m

CABLES

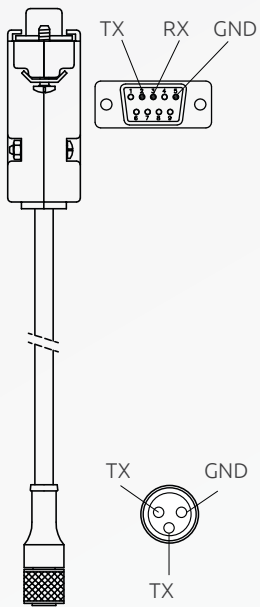

CSL 3 METRON PROGRAMMING CABLE

Model	Code	Description
CSL 3	1330994	3 meters cable, for connecting light curtain and PC for system configuration, equipped with one M8 3-pole connector and one DB9 connector

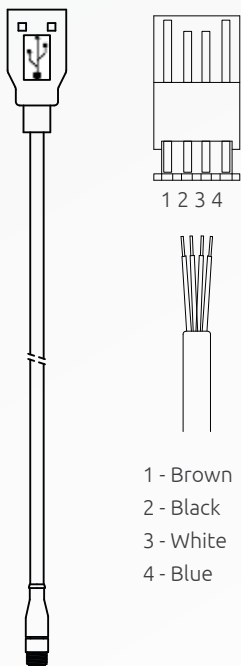

CSU M5 MICRON PROGRAMMING CABLE

Model	Code	Description
CSU M5	1250900	2 meters cable, for connecting light curtain and PC for system configuration, equipped with one M5 4-pole connector and one USB A connector



Support columns for ReeR safety light curtains, designed to provide secure fastening to the floor, fast installation, and a simple and precise adjustment of the optical alignment of the system.



Steel base with springs for a perfect adjustment of the column vertical axis.

FMC BR models for light curtains complete with PG11 rear union for light curtain cable sheath.

Columns made by aluminium extrusion poles, with adjustable angular orientation. Easy assembling and disassembling of the light curtain with easy adjustment of the first beam's height.

Steel foundation inserts included with the product.

Built-in spirit level for a correct positioning of the vertical axis.



FMC EB / FMC EBR

FLOOR SUPPORT COLUMNS FOR MICRON LIGHT CURTAINS

PART NUMBERS

Columns

Standard models	FMC EB 2	FMC EB 4	FMC EB 1700	FMC EB 2000
Ordering codes	1207814	1207815	1207816	1207817
Models with PG11 rear union for cable sheath	FMC EB 2 R	FMC EB 4 R	FMC EB 1700 R	FMC EB 2000 R
Ordering codes	1207824	1207825	1207826	1207827
A - Height (mm)	1000	1200	1670	1970
B - Overall height with FMC CB base (mm)	1055	1255	1725	2025
B - Overall height with FMC CBL base (mm)	1037	1237	1707	2007

Bases for columns

Models	FMC CB	FMC CBL
Ordering codes	1200500	1200501
Description	Base for column	Base for column with reduced height
Height (mm)	55	37

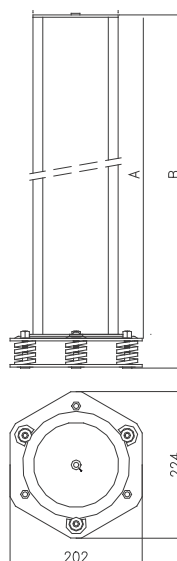

A: column height
B: column height with base FMC CB or FMC CBL

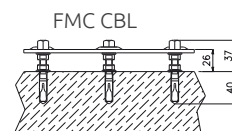
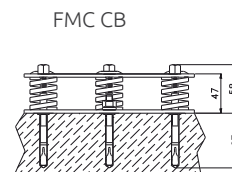

COLUMNS



Support columns for ReeR safety light curtains, designed to provide secure fastening to the floor, fast installation, and a simple and precise adjustment of the optical alignment of the system.

FMC B / FMC BR

FLOOR SUPPORT COLUMNS FOR METRON LIGHT CURTAINS

PART NUMBERS

Columns

Standard models	FMC B 2	FMC B 3	FMC B 4	FMC B 1700	FMC B 2000
Ordering codes	1200610	1200611	1200612	1200618	1200616
Models with PG11 rear union for cable sheath	FMC B 2 R	FMC B 3 R	FMC B 4 R	FMC B 1700 R	FMC B 2000 R
Ordering codes	1200613	1200614	1200615	1200617	1200619
A - Height (mm)	1000	1200	1330	1670	1970
B - Overall height with FMC CB base (mm)	1055	1255	1385	1725	2025
B - Overall height with FMC CBL base (mm)	1037	1237	1367	1707	2007

Bases for columns

Models	FMC CB	FMC CBL
Ordering codes	1200500	1200501
Description	Base for column	Base for column with reduced height
Height (mm)	55	37

FMC-B12 / B18 SUPPORT COLUMNS

PART NUMBERS

Model	FMC-B12	FMC-B18
Ordering codes	1200502	1200505
Dimensions (mm)	60 x 30	80 x 80
Height (mm)	1200	1800
Overall height with FMC CB base (mm)	1255	1255
Overall height with FMC CBL base (mm)	1237	1237



Simplified version for Micron and Metron.

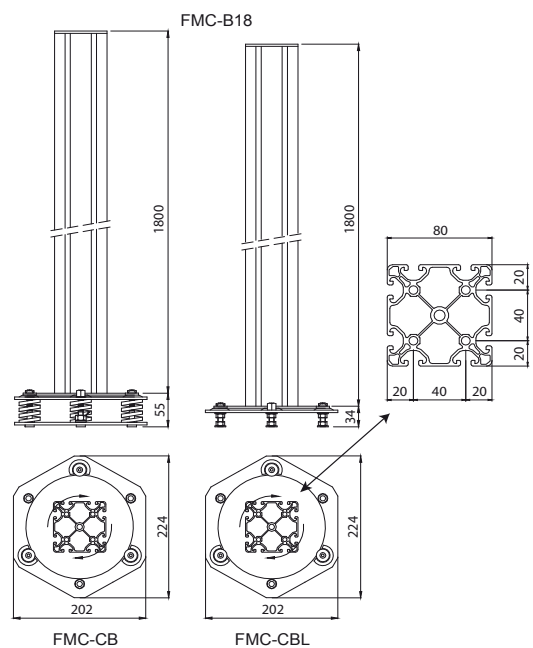
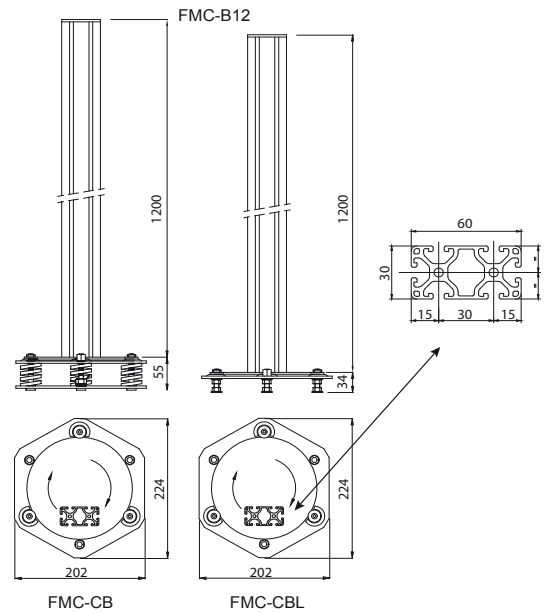

BRACKETS



The SFB 4E / SFB 6E swivel brackets allow the rotation of the light curtain around its longitudinal axis, as well as the adjustment of its vertical and horizontal position.



The SFB E180 swivel brackets allow the 180° rotation of the light curtain around its longitudinal axis, as well as the adjustment of its vertical and horizontal position.

SFB 4E / SFB 6E

MICRON SWIVEL BRACKETS

PART NUMBERS

Model	Ordering codes	Description
SFB 4E	1310976	Set of 4 swivel brackets for Micron with length \leq 1200 mm
SFB 6E	1310977	Set of 6 swivel brackets for Micron with length \geq 1200 mm
One set must be ordered for each pair of light curtain (emitter + receiver)		

SFB E180

MICRON 180° SWIVEL BRACKETS

PART NUMBERS

Model	Ordering code	Description
SFB E180	1310980	Set of 4 180° swivel brackets for Micron
One set must be ordered for each pair of light curtain (emitter + receiver)		



The FE 4 brackets, with a thickness of only 4 mm, allow proper fastening of Micron light curtains.



The SFB swivel brackets allow the rotation of the light curtain around its longitudinal axis, as well as the adjustment of its vertical and horizontal position.

FLAT FE 4

MICRON FLAT BRACKETS

PART NUMBERS

Model	Ordering code	Description
FE 4	1310997	Set of 4 flat brackets for Micron
One set must be ordered for each pair of light curtain (emitter + receiver)		

SFB

METRON SWIVEL BRACKETS

PART NUMBERS

Model	Ordering code	Description
SFB	1330974	Set of 4 swivel brackets for Metron
One set must be ordered for each pair of light curtain (emitter + receiver)		



LAD 2 and LAD 4 laser alignment device allows a fast and reliable optical alignment of ReeR safety light curtains; also compatible with the use of the FMC floor mounting columns.

LAD 2 and LAD 4 devices emit a laser beam with visible red light with useful range up to 100 m.

LAD 4 - LAD 2

LASER ALIGNEMENT DEVICE

TECHNICAL FEATURES

Light source	Laser diode – wavelength 650 nm
Class light source	II – EN 60825-1
Range m	100
Beam divergence (mrd)	< 0,5
Max. power (mW)	1
Power supply (VDC)	3 (2 AAA batteries)
Fastening	Quick fastening to the light curtains
Dimensions h x w x d (mm)	117 x 48 x 80 - LAD 2 - LAD 4

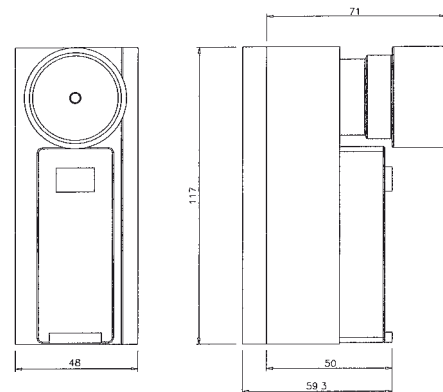

PART NUMBERS

Includes multi-language instruction manual.

Ordering code LAD 2 for Metron: **1310975**

Ordering code LAD 4 for Micron: **1220301**

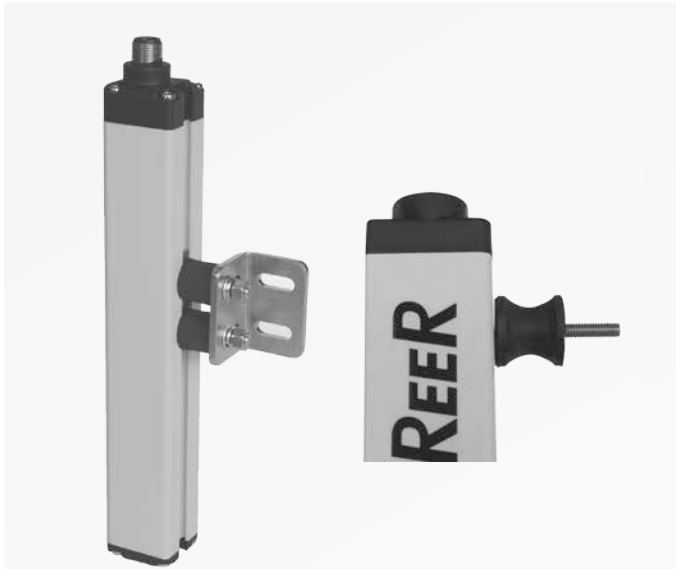

The SAV vibration dampers have been designed to avoid mechanical damage to the light curtains installed in those applications with have a high level of vibrations.



PSE is a polycarbonate protective screen that preserves the light curtain's front screen from damages due to welding sparks or due to the presence of acids in the workspace.

Protective screens can be quickly replaced thanks to the fast and easy stainless steel clamping system.

SAV 4E, SAV 8E, SAV 12E MICRON VIBRATION DAMPERS

PART NUMBERS

Model	Ordering codes	Description	For light curtains with protected height mm / beams
SAV 4E	1310972	Set 4 vibrations dampers	160
SAV 8E	1310973	Set 8 vibrations dampers	310 ... 1050
SAV 12E	1310974	Set 12 vibrations dampers	1210 ... 1810 / 2,3,4
One set must be ordered for each pair of light curtain (emitter + receiver)			

SAV 3, SAV 4 METRON VIBRATION DAMPERS

PART NUMBERS

Model	Ordering codes	Description	For light curtains with protected height mm / beams
SAV 3	1200088	Set 2 vibrations dampers	160... 1060 / 2,3,4 beams
SAV 4	1120089	Set 3 vibrations dampers	1210 ... 1810
One set must be ordered for each pair of light curtain (emitter + receiver)			

SFS - PSE MICRON PROTECTIVE SCREEN

PART NUMBERS

Each kit includes:

- SFS E (ordering code 1310981) - 1 set of stainless steel clamps for one safety light curtain (emitter and receiver)
- PSEx (ordering codes from 1310982 to 1310995 according to the length of light curtain) - 4 protective screens (2 as spare parts)

For each pairs of safety light curtain (emitter and receiver) it's necessary orderd both codes.

Models	PSE 150	PSE 300	PSE 450	PSE 600	PSE 750	PSE 900
Ordering codes	1310982	1310983	1310984	1310985	1310986	1310987
Models	PSE 1050	PSE 1200	PSE 1350	PSE 1500	PSE 1650	PSE 1800
Ordering codes	1310988	1310989	1310990	1310991	1310992	1310996
Models	PSE 2B	PSE 3B	PSE 4B			
Ordering codes	1310993	1310994	1310995			



At ReeR we put our Customers always first

ReeR after sales service is committed to support all customers that need technical guidance regarding functionality, handling and installation of our products.

Customer Service Hotline

+39 011 24 82 215

Monday to Friday 8.30 -12.30 and 13.30-18.00 (CET)

or contact

aftersales@reer.it

For product returns please visit www.reersafety.com for further information.

Safety. Detection. Control.



ReeR SpA

Via Carcano, 32

10153 Torino

Italy

T +39 011 248 2215

F +39 011 859 867

www.reersafety.com | info@reer.it



More than 50 years of quality and innovation

Founded in Turin (Italy) in 1959, ReeR distinguished itself for its strong commitment to innovation and technology.

A steady growth throughout the years allowed ReeR to become a point of reference in the safety automation industry at a worldwide level.

The Safety Division is in fact today a world leader in the development and manufacturing of safety optoelectronic sensors and controllers.

ReeR is ISO 9001, ISO 14001 and BS OHSAS 18001 certified.



Issue 1

Rev. 0.1
January 2017
8946226
Printed in Italy

Micron Metron Catalogue English

ReeR SpA does not guarantee that product information in this catalogue are the most current available. ReeR SpA reserves the right to make changes to the products described without notice and assumes no liability as a result of their use or application. Our goal is to keep the information on this catalogue timely and accurate, however ReeR SpA accepts no responsibility or liability whatsoever with regard to the information on this catalogue. Reproduction is not authorised, except with the expressed permission of ReeR SpA.

