

POSICHRON® PCST25 Rod-Style Design with Analog Output

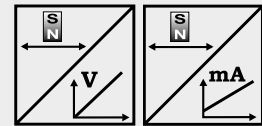

POSICHRON® rod-style position sensor

- For hydraulic cylinders, fluid level measurement
- Protection class IP67/69K
- Measurement range 0 ... 100 to 0 ... 5750 mm
- Absolute position measurement
- Contact-free
- Height of sensor head 16 mm max. incl. cable outlet
- Analog output



Specifications	Output	Voltage Current
	Resolution	
Sampling rate		Up to 1 kHz, depending on the measurement range
Linearity		Ranges >500 mm: L10 = ±0.10 % f.s. L02 = ±0.02 % f.s. Ranges ≤500 mm: L10 = ±0.5 mm L02MM = ±0.2 mm
Repeatability		±3 µm
Housing material		Sensor rod: stainless steel 1.4404, head: AlMgSi
Mounting		Thread M18x1,5 / thread ¾ inch / plug-in mounting
Operating pressure		400 bar, other values on request
Protection class		IP67/69K
Shock		EN 60068-2-27:1993, 50 g 11 ms, 100 shocks
Vibration		EN 60068-2-6:1995, 20 g 10 Hz-2 kHz, 10 cycles
Connection		Cable 2 m
EMC, temperature		Refer to output specification

Order code position magnet (see page 8-12)

PCSTMAG ...

POSICHRON® PCST25 Rod-Style Design with Analog Output



Order Code PCST25

1 or 2 channel,
configurable



Model name

Mounting

- M18 = Thread M18 x 1,5
- Z3/4 = Thread 3/4"-16UNF
- SV = plug-in mounting

Measurement range (in mm)

100 ... 5750 in 10 mm increments

Output

- U2 = 0.5 ... 10 V signal conditioner
- U2/U, U2/H = U2 with AlarmLOW, U2 with AlarmHOLD (see page 77)
- U8 = 0.5 ... 4.5 V signal conditioner
- I1 = 4 ... 20 mA signal conditioner (3 wire)
- I1/U, I1/H = I1 with AlarmLOW, I1 with AlarmHOLD (see page 77)

Function and characteristics output 1

- P1A = Position magnet 1, increasing
- P1D = Position magnet 1, decreasing
- PMU = Start value, direction and end value adjustable by the customer (1 channel only)
- DA = Difference magnet 1/2, increasing (2 magnets required)
- DD = Difference magnet 1/2, decreasing (2 magnets required)

Function and characteristics output 2 (option)

- P2A = Position magnet 2, increasing
 - P2D = Position magnet 2, decreasing
 - DA = Difference magnet 1/2, increasing
 - DD = Difference magnet 1/2, decreasing
- } 2 magnets required

VZx.x = Velocity with direction detection (only with one magnet)

VZx.x = Velocity in steps of 0.1 m/s

Example: VZ1.5	towards start position		towards end position
	-1.5 m/s	0	+1.5 m/s
Output U2:	0.5 V	5.25 V	10 V
Output I1:	4 mA	12 mA	20 mA

VAx.x = Velocity without direction detection (only with one magnet)

VAx.x = Velocity in steps of 0.1 m/s

Example: VA1.5	towards start position		towards end position
	-1.5 m/s	0	+1.5 m/s
Output U2:	10 V	0.5 V	10 V
Output I1:	20 mA	4 mA	20 mA

Linearity

L02 / L02MM / L10 (for definition see previous page, "Specifications")

Connection

KAB2M = Cable, standard length 2 m, other lengths upon request

1. Order example: PCST25 - M18 - 1000 - U2 - P1D - L10 - KAB2M

Rod-style design, measurement range 1000 mm, 1 voltage output 0.5 ... 10 V (U2)
Output 1: Position magnet 1, decreasing signal (P1D)
Output 2: Not used

2. Order example: PCST25 - M18 - 1000 - I1 - P1A - P2D - L10 - KAB2M

Rod-Style Design, measurement range 1000 mm, 2 current outputs 4 ... 20 mA (I1)
Output 1: Position magnet 1, increasing signal (P1A)
Output 2: Position magnet 2, decreasing signal (P2D)

3. Order example: PCST25 - M18 - 1000 - U2 - P1A - VZ1.0 - L10 - KAB2M

Rod-Style Design, measurement range 1000 mm, 2 voltage outputs 0.5 ... 10 V (U2)
Output 1: Position magnet 1, increasing signal (P1A)
Output 2: Velocity magnet 1, -1 m/s ... 1 m/s for range 0,5 ... 10 V (VZ1.0)

POSICHRON® PCST25 Rod-Style Design with SSI Output



POSICHRON® rod-style position sensor

- For hydraulic cylinders, fluid level measurement
- Protection class IP67/69K
- Measurement range 0 ... 100 to 0 ... 5750 mm
- Absolute position measurement
- Contact-free
- Height of sensor head 16 mm max. incl. cable outlet
- Synchronous serial interface (SSI)

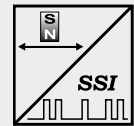

Specifications		
Output		Synchronous serial interface (SSI)
Resolution		50, 100 µm
Sampling rate		Up to 1 kHz, depending on the measurement range
Linearity		Ranges >500 mm: L10 = ±0.10 % f.s. L02 = ±0.02 % f.s. Ranges ≤500 mm: L10 = ±0.5 mm L02MM = ±0.2 mm
Repeatability		±3 µm
Housing material		Sensor rod: stainless steel 1.4404, head: AlMgSi
Mounting		Thread M18x1,5 / thread ¾ inch / plug-in mounting
Working pressure		400 bar, other values on request
Protection class		IP67/69K
Shock		EN 60068-2-27:1993, 50 g/11 ms, 100 shocks
Vibration		EN 60068-2-6:1995, 20 g 10 Hz-2 kHz, 10 cycles
Connection		Cable 2 m
EMC, temperature		Refer to output specification

Order Code PCST25



Model name

Mounting

- M18 = Thread M18x1,5
- Z3/4 = Thread ¾ "-16 UNF
- SV = Plug-in version

Measurement range (in mm)

100 ... 5750 in 10 mm increments

Resolution (in µm)

50 / 100

Output

SSI = Synchronous serial interface

Average determination (filter: number of measurements)

F1 / F2 / F4 / F8

Code

G / D = Gray / Dual

Number of data bits

24 / 25

Linearity

L02 / L02MM / L10 (for definition see "Specifications" above)

Connection

KAB2M = Cable, standard length 2 m, other lengths upon request

Order code position magnet (see page 8-12)

PCSTMAG ...

Order example: PCST25 - M18 - 1500 - 50 - SSI/F8/G/24 - L02 - KAB2M

POSICHRON® PCST25 Rod-Style Design with CANopen Output



POSICHRON® rod-style position sensor

- For hydraulic cylinders, fluid level measurement
- Protection class IP67/69K
- Measurement range 0 ... 100 to 0 ... 5750 mm
- Absolute position measurement
- Contact-free
- Height of sensor head 16 mm max. incl. cable outlet
- CANopen output or CAN SAE J1939 output

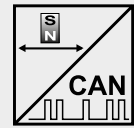

Specifications		
Output		CANopen; CAN SAE J1939
Resolution		50 µm
Sampling rate		Up to 1 kHz, depending on the measurement range
Linearity		Ranges >500 mm: L10 = ±0.10 % f.s. L02 = ±0.02 % f.s. Ranges ≤500 mm: L10 = ±0.5 mm L02MM = ±0.2 mm
Repeatability		±3 µm
Housing material		Sensor rod: stainless steel 1.4404, head: AlMgSi
Mounting		Thread M18x1,5 / thread ¾ inch / plug-in mounting
Working pressure		400 bar, other values on request
Protection class		IP67/69K
Shock		EN 60068-2-27:1993, 50 g/11 ms, 100 shocks
Vibration		EN 60068-2-6:1995, 20 g 10 Hz-2 kHz, 10 cycles
Connection		Cable (length 0.3 m) with 5-pin connector M12
EMC, temperature		Refer to output specification

Order code PCST25

PCST25 - [] - [] - [] - [] - []

Model name

Mounting

- M18 = Thread M18 x 1,5
- Z3/4 = Thread ¾ "-16UNF
- SV = Plug-in version

Measurement range (in mm)

- 100 ... 5750 in 10 mm increments
- Other ranges on request

Output

- CANOP = CANopen bus
- CANOP/R = CANopen bus with integrated terminating resistor
- CANJ1939 = CAN SAE J1939

Linearity

- L02 / L02MM / L10 (for definition see "Specifications" above)

Connection

- KAB0,3M-M12/CAN = Cable (length 0.3 m) with 5-pin connector M12

Order code position magnet (see page 8-12)

PCSTMAG ...

Order code bus cable (see page 19)

KAB- ...M-M12/5F/G-M12/5M/G-CAN

Order example: PCST25 - M18 - 2500 - CANOP - L10 - KAB0,3M-M12/CAN

POSICHRON[®]
PCST25
Rod-Style Design

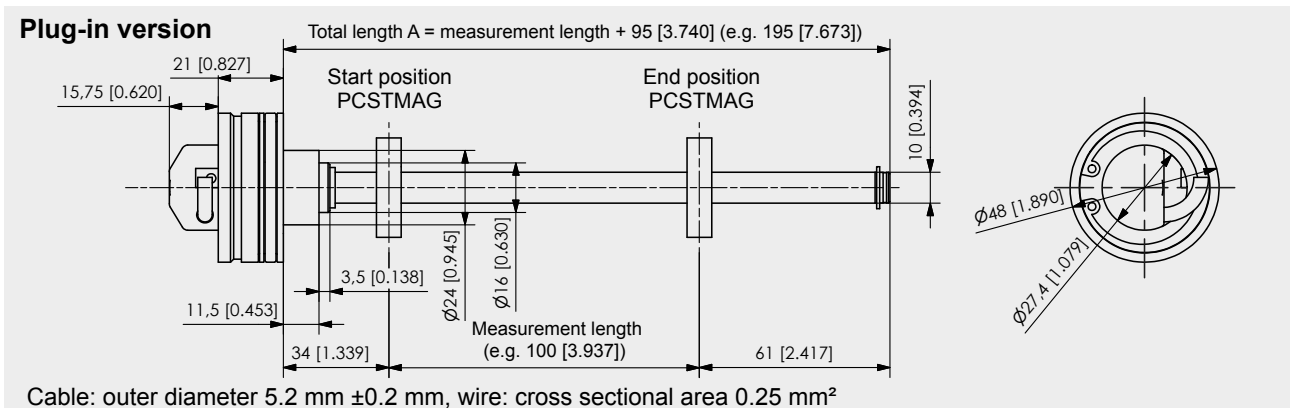
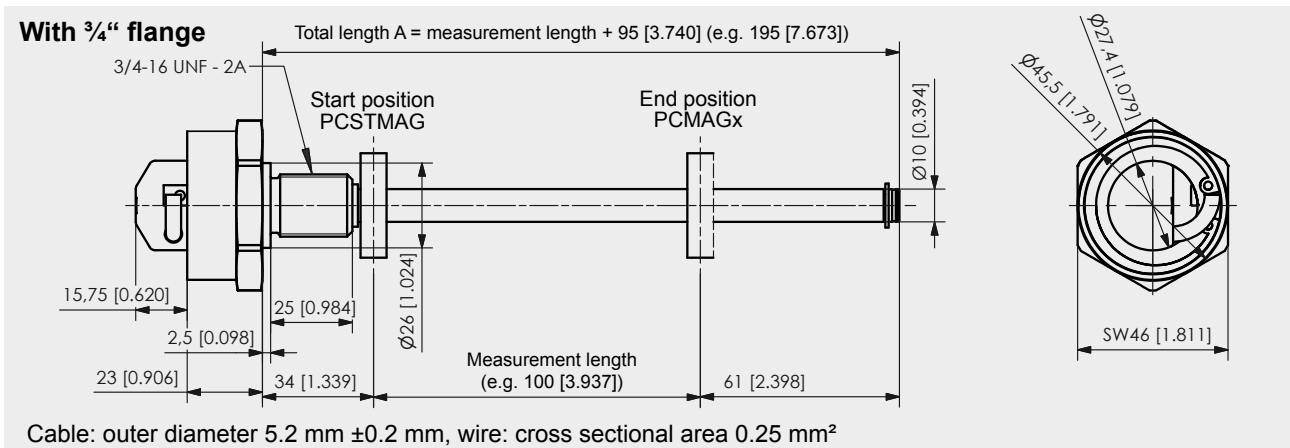
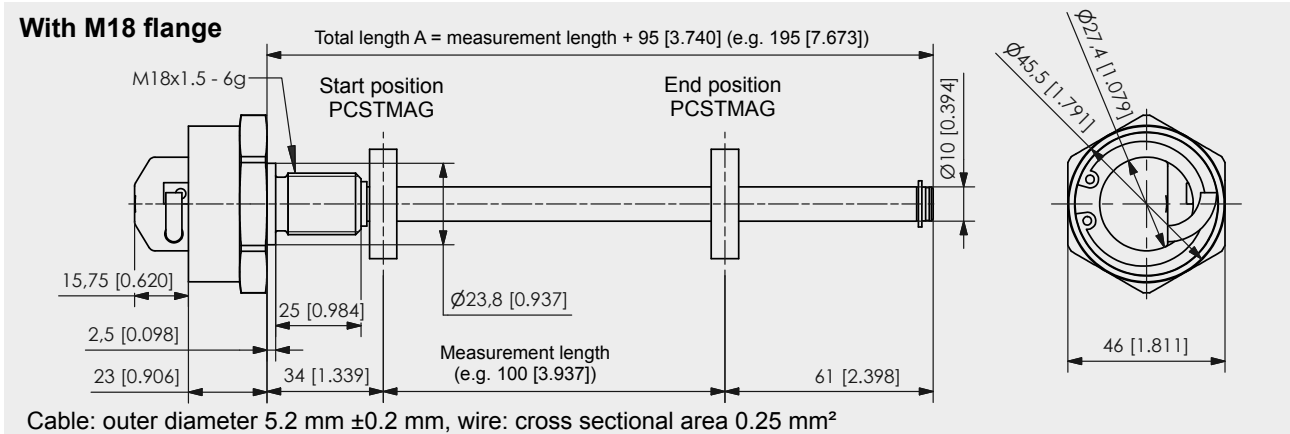

Dimensions in mm [inch]

Dimensions informative only.
 For guaranteed dimensions consult factory.

Mounting hole
M18

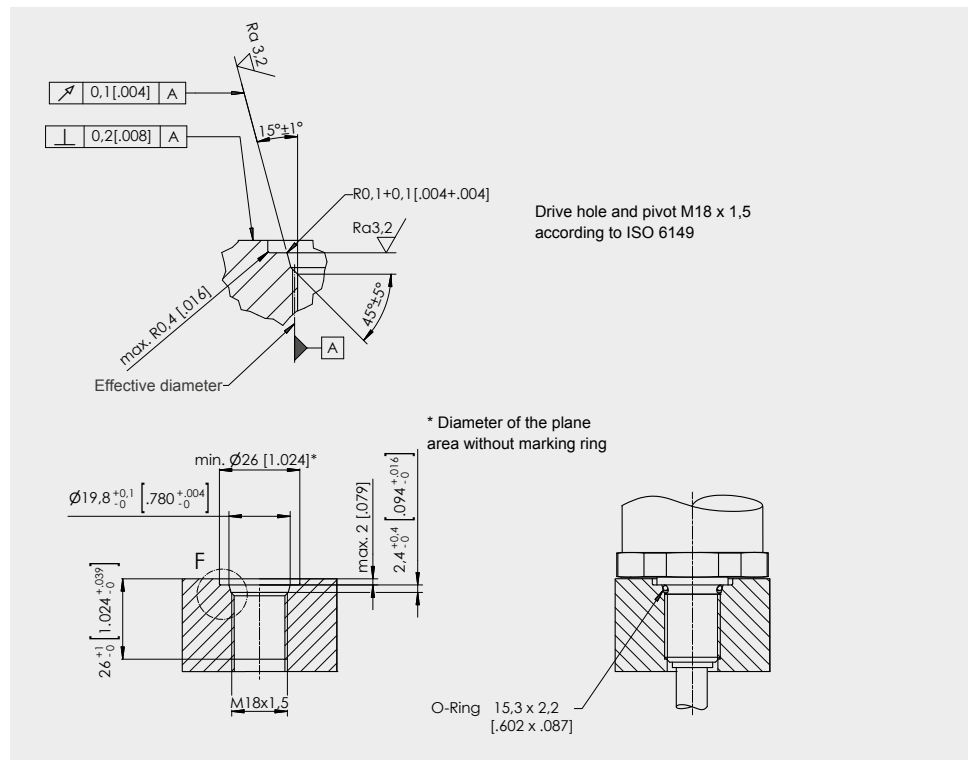

Dimensions in mm [inch]

Dimensions informative only.
 For guaranteed dimensions consult factory.

Mounting hole
3/4 inch

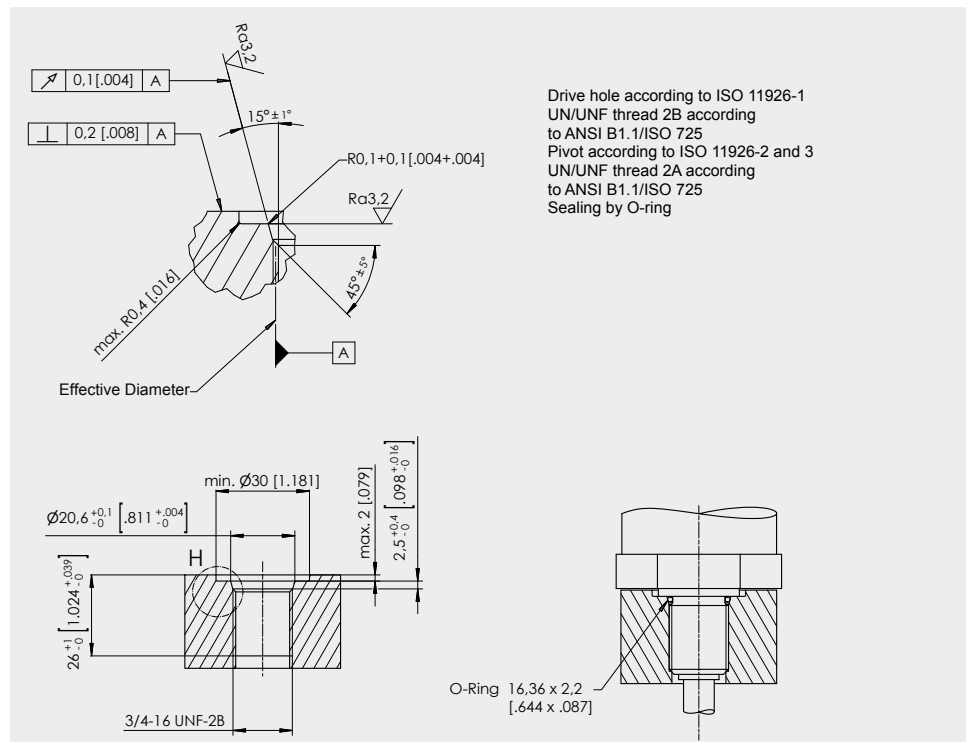

Dimensions in mm [inch]

Dimensions informative only.
For guaranteed dimensions consult factory.

PCSTMAG1

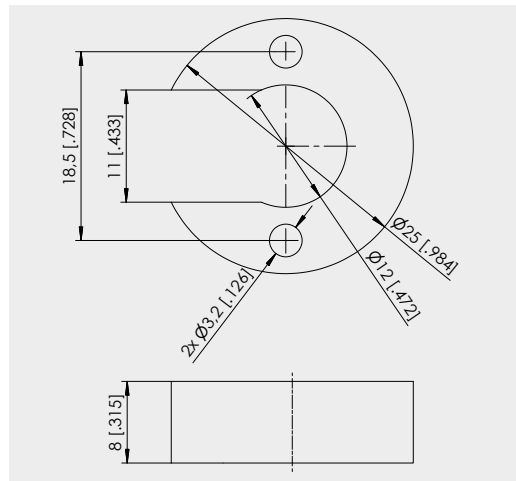

PCSTMAG2
 (standard)

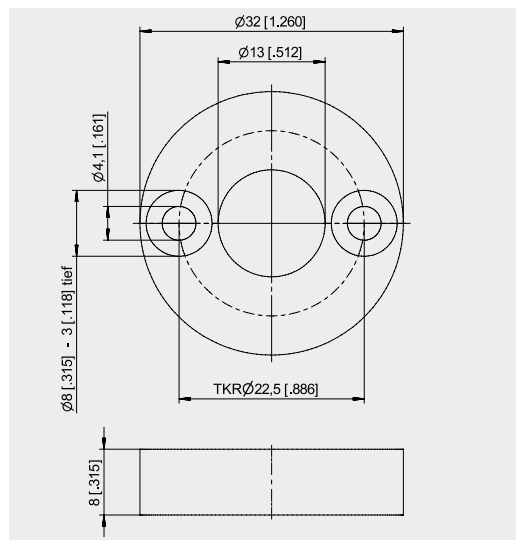

PCSTMAG5

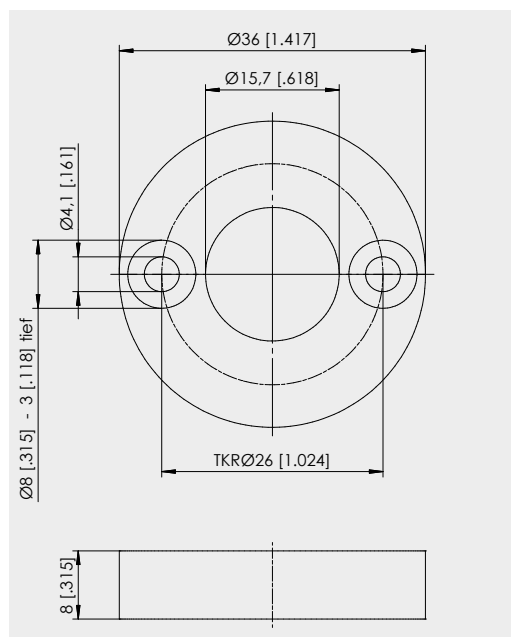

Dimensions in mm [inch]

Dimensions informative only.
 For guaranteed dimensions consult factory.
 Other designs can be realized on request

PCSTMAG2-MH1

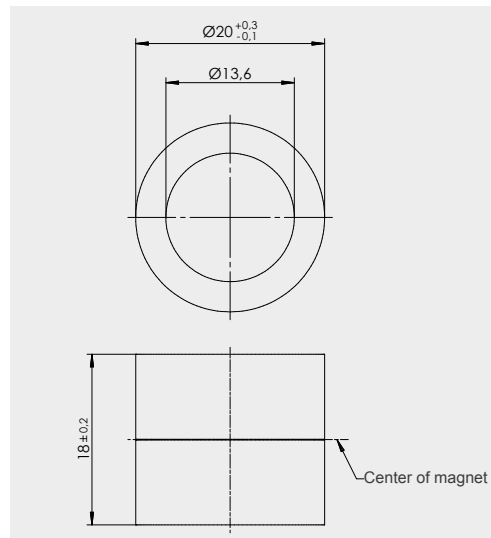

PCSTMAG2-MH2

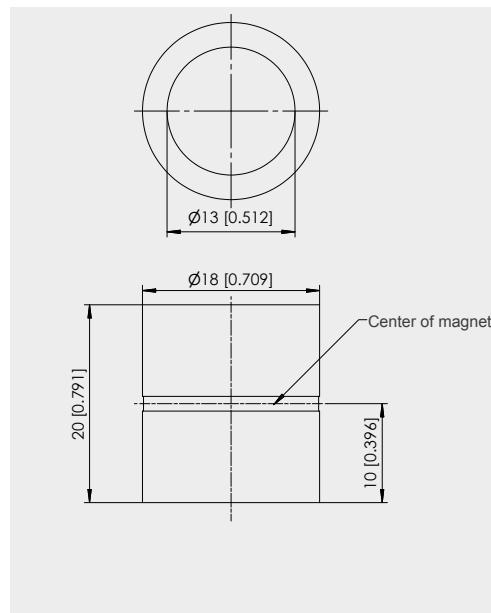

PCSTMAG2-MH3

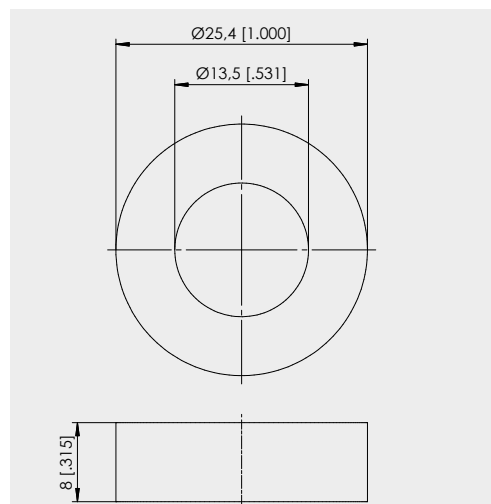

Dimensions in mm [inch]

Dimensions informative only.
 For guaranteed dimensions consult factory.
 Other designs can be realized on request

PCSTMAG2-G1

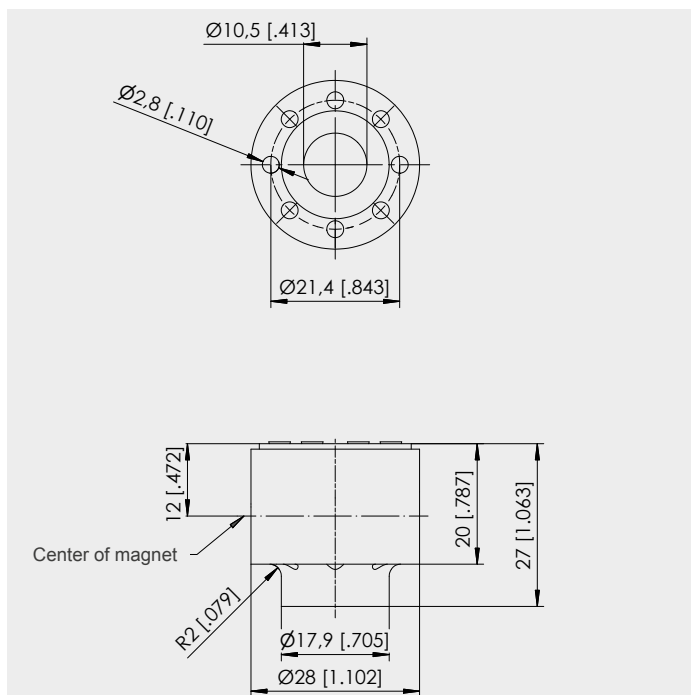

PCSTMAG2-G2

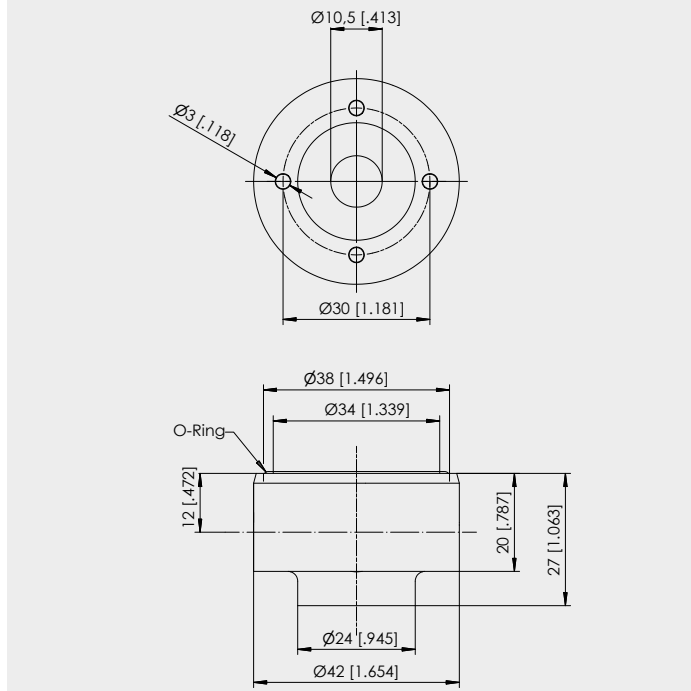

PCSTMAG2 - G1 / G2

Sliding magnet with special self-lubricating and abrasion-resistant material. To be used if sensor is mounted in horizontal position and a mechanical support of the rod is not possible for measurement ranges >1000 mm.

Dimensions in mm [inch]

Dimensions informative only.
 For guaranteed dimensions consult factory.
 Other designs can be realized on request

PCSTMAG7

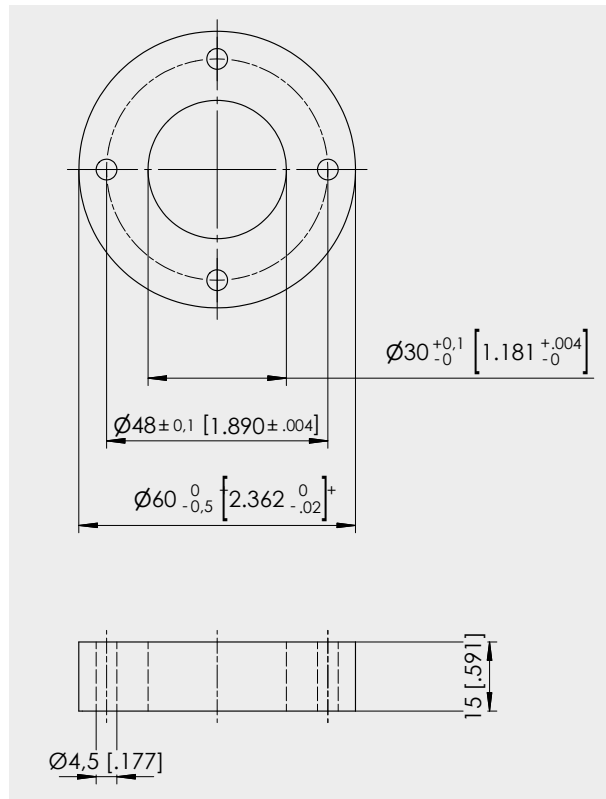

PCSTMAG4

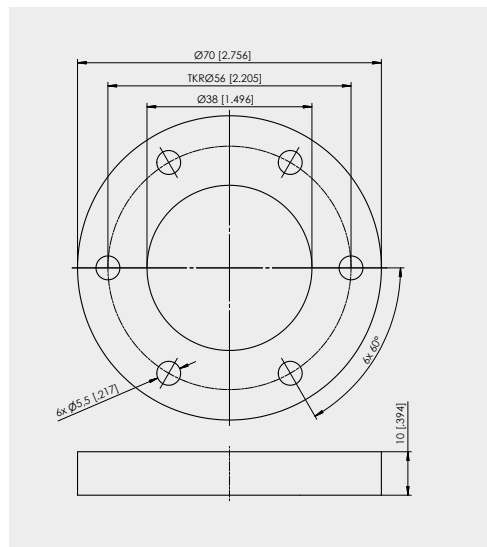

Dimensions in mm [inch]

Dimensions informative only.
For guaranteed dimensions consult factory.
Other designs can be realized on request

PCSTMAG3

(float, continuous pressure up to 9 bar, for media with a specific gravity of $\geq 0,75 \text{ g/cm}^3$)

Material: 1.4404

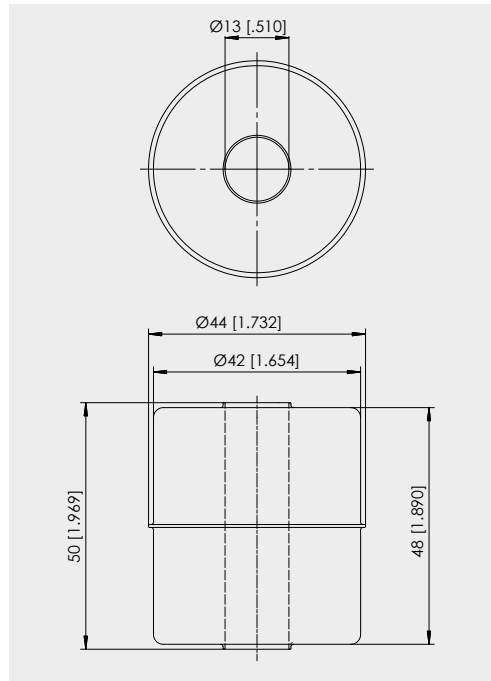

Note: Dependent on the design the available measurement range is reduced of 25 mm on both ends!

PCSTMAG6

(float, continuous pressure up to 30 bar, for media with a specific gravity of $\geq 0,7 \text{ g/cm}^3$)

Material: 1.4571

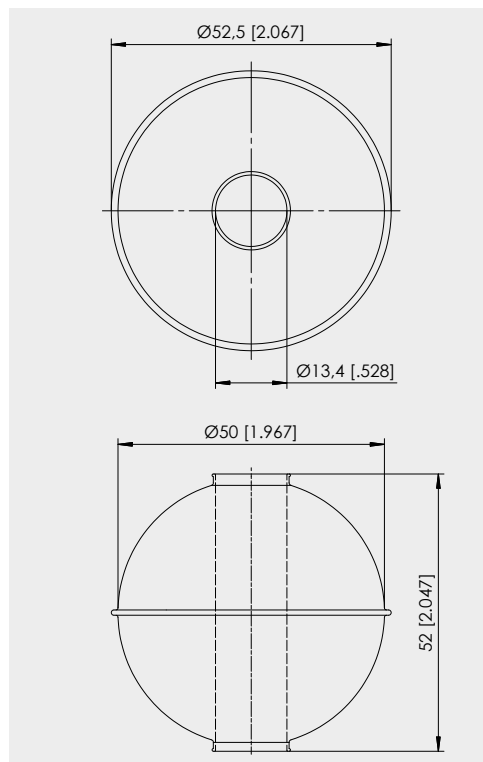

Note: Dependent on the design the available measurement range is reduced of 25 mm on both ends!

Dimensions in mm [inch]

Dimensions informative only.
 For guaranteed dimensions consult factory.
 Other designs can be realized on request

POSICHRON®

Output Specification U2, U8 and I1

Configurable, 1 or 2 channels



Signal conditioner U2, U8 Voltage output 	Excitation voltage	U2: 18 ... 27 V DC; U8: 10 ... 36 V
	Excitation current	Typ. 35 mA, 80 mA max.
	Output voltage	U2: 0.5 ... 10 V; U8: 0.5 ... 4.5 V
	Output current	2 mA max.
	Output load	> 5 kΩ
	Resolution	16 bit
	Stability (temperature)	$\pm 50 \times 10^{-6} / ^\circ\text{C}$ f.s.
	Protection	Reverse polarity, short circuit
	Output noise	0.5 mV _{RMS}
	Operating temperature	-40 ... +85 °C
Immunity to interference (EMC)	According to EN 61326:2004	

Signal diagram

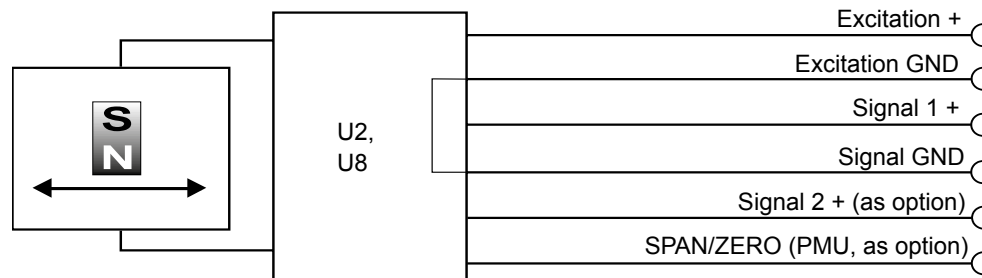

Signal conditioner I1 Current output (3 wire) 	Excitation voltage	18 ... 27 V DC
	Excitation current	Typ. 60 mA, 80 mA max.
	Load resistor	350 Ω max.
	Output current	4 ... 20 mA, 30 mA max (at failure)
	Resolution	16 bit
	Stability (temperature)	$\pm 50 \times 10^{-6} / ^\circ\text{C}$ f.s.
	Protection	Reverse polarity, short circuit
	Output noise	0.5 mV _{RMS}
	Operating temperature	-40 ... +85 °C
Immunity to interference (EMC)	According to EN 61326:2004	

Signal diagram

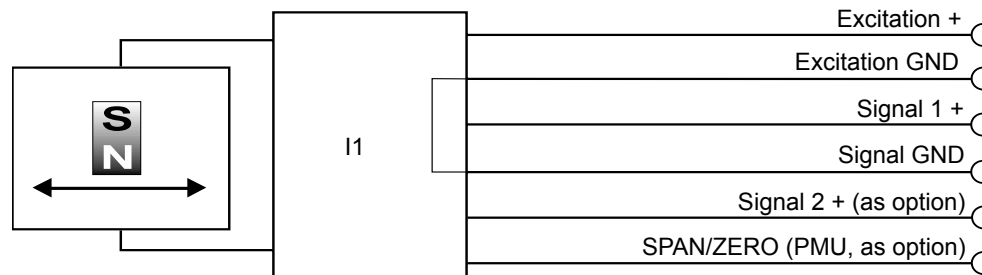

Signal wiring	Output sigals U2, U8, I1	Connector pin	Cable output, wire color (not for PCST27 and PCR32)
	Excitation +	1	white
	Excitation GND	2	brown
	Signal 1 +	3	green
	Signal GND	4	yellow
	Signal 2 + (as option *)	5	grey
	SPAN/ZERO (PMU **, as option)	6	pink

* When using multiple magnets the distance between two magnets must be min. 70 mm to identify the single magnets definitely.

** Description page 59

Connection

Mating connector

View to
sensor
connector

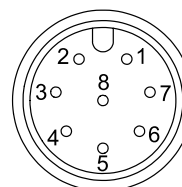

CONN-M12-8M

Option - PMU for analog output U2, U8 and I1

Programming of the start and end value by the customer:

The option PMU allows to program the start value and the end value of the output range by a programming signal SPAN/ZERO available at the connector. This Signal SPAN/ZERO must be connected with GND via a push button, then position magnet of the sensor must be moved to the start resp. end position. Pushing the button between 1 and 4 seconds sets the actual position as start position, pushing the button more than 5 seconds sets the actual position as end position. The values will be stored and are available after switching off the sensor.

To reset the sensor to the factory values the button must be pushed when the sensor is switched on.

Diagnostic signal on error for U2 and I1

The analog signal output in case of error

In case of error (e.g. magnet missing) the analog output signal will assume a state according to the following options:

Standard (w/o marking): Alarm_HIGH:	The output voltage resp. the output current is at HIGH level (overrange)
Option /U: Alarm_LOW:	The output voltage resp. the output current is at LOW level (underrange)
Option /H: Alarm_HOLD:	The output voltage resp. the output current will keep the last valid state

Option F1/F2/F4/F8 for SSI output

Filter function of the SSI interface

The option „Filter“ Fn calculates the floating average over a sample of measurement values. With the sample size the settling time of the measured value will be extended. Suitable sample sizes are 2, 4 and 8.

Error signal for SSI output

If the sensor cannot detect a magnet the position value will assume the maximum value (0xFFFFFFFF)

POSICHRON® Output Specification SSI



Description

The data transmission takes place by means of the two signals CLOCK and DATA. The processing unit (PLC, microcomputer) sends pulse sequences which clock the data transmission at the required transfer rate. With the first falling edge of the pulse sequence the position of the sensor is recorded and stored. The following rising edges control the bit-by-bit transfer of the data word. After a delay time the next new position information can be transmitted.

Data format (Train of 26 pulses)

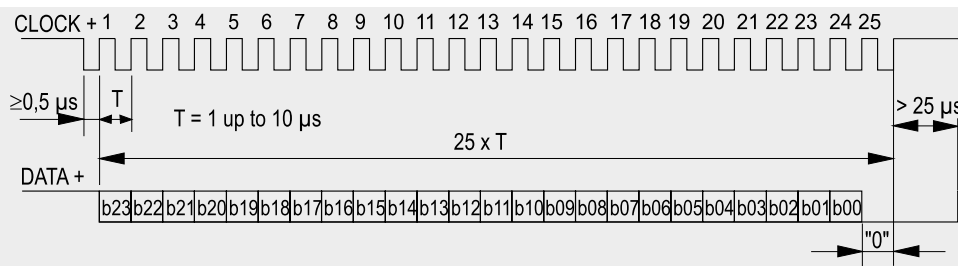

Synchronous serial interface SSI

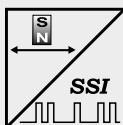

Output	RS422
Excitation voltage	18 ... 27 V DC, residual ripple 10 mV _{SS}
Excitation current	Typ. 80 mA, 150 mA max.
Clock frequency	100 kHz ... 1 MHz
Code	Gray code, dual code
Resolution	≥ 5 μm
Delay between pulse trains	>25 μs
Filter	Average determination, see page 59
Stability (temperature)	±50 x 10 ⁻⁶ / °C f.s.
Operating temperature	-40 ... +85 °C
Immunity to interference EMC	According to EN 61326:2004

Signal diagram

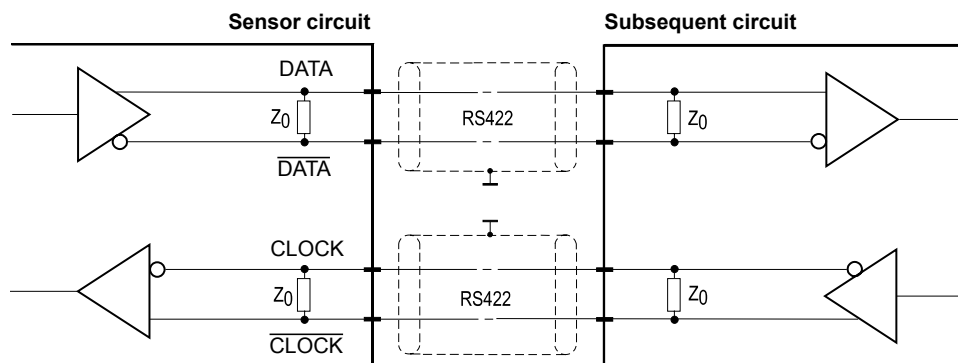

Cable length	Baud rate
50 m	100-1000 kHz
100 m	100-300 kHz

Note:
Extension of the cable length will reduce the maximum transmission rate.
The signals CLOCK/CLOCK and DATA/DATA must be connected in a twisted pair cable, common shielded.

Signal wiring

Signal name	Connector pin	Cable output color (not for PCST27 and PCR32)
Excitation +	1	white
Excitation GND	2	brown
CLOCK	3	green
CLOCK	4	yellow
DATA	5	grey
DATA	6	pink

View to sensor connector

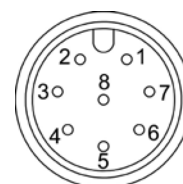

CONN-M12-8M

Filter option F1/F2/F4/F8 and error indication see page 14.

POSICHRON® Output Specification CANopen



Description

CANopen interface with process data for position and cam functions, programmable are preset, resolution, filtering and cam switching points.

Interface CANOP

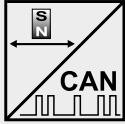

Communication profile	CANopen CiA 301 V 4.02, Slave
Encoder profile	Encoder CiA 406 V 3.2
Error Control	Node Guarding, Heartbeat, Emergency Message
Node ID	Adjustable via LSS or via object dictionary
PDO	4 TxPDO, 0 RxPDO, no linking, static mapping
PDO Modes	Event-/Time triggered, Remote-request, Sync cyclic/acyclic
SDO	1 server, 0 client
CAM	2 cams
Certified	Yes
Transmission rates	50 kBaud to 1 MBaud, adjustable via LSS or via object dictionary
Nodes	127 max.
Bus connection	M12 connector, 5 pins
Integrated bus terminating resistor	As option (output CANOP/R)
Bus, galvanic isolated	No

Specifications

Excitation voltage	18 ... 36 V DC
Excitation current	Typ. 20 mA for 24 V, max. 100 mA
Number of position magnets	1 ... 4
Resolution	50 µm
Measuring rate	1 kHz (asynchronous)
Stability (temperature)	±50 x 10 ⁻⁶ / °C f.s.
Repeatability	1 LSB
Operating temperature	-40 ... +85 °C
Protection	Reverse polarity, short circuit
Dielectric strength	500 V (V AC, 50 Hz, 1 min.)
Environment - EMC Automation	EN 61326-1:2006

When using multiple magnets the distance between two magnets must be min. 70 mm to identify the single magnets definitely.

Signal wiring / connection

Signal name	Connector pin (color)
Shield	1 (grey)
Excitation +	2 (white)
GND	3 (brown)
CAN-H	4 (green)
CAN-L	5 (yellow)

View to sensor connector

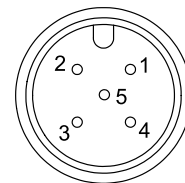

POSICHRON®

Output Specification CAN SAE J1939

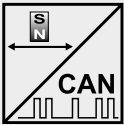

Interface J1939 	CAN specification	ISO 11898, Basic and Full CAN 2.0 B
	Transceiver	24V-compliant, not isolated
	Communication profile	SAE J1939
	Baud rate	250 kbit/s
	Internal termination resistor	120 Ω
	Address	Default 247d, configurable

NAME Fields	Arbitrary address capable	1	Yes
	Industry group	0	Global
	Vehicle system	7Fh (127d)	Non specific
	Vehicle system instance	0	
	Function	FFh (255d)	Non specific
	Function instance	0	
	ECU instance	0	
	Manufacturer	145h (325d)	Manufacturer ID
	Identity number	0nnn	Serial number 21 bit

Parameter Group Numbers (PGN)	Configuration data	PGN EF00h	Proprietary-A (PDU1 peer-to-peer)
	Process data	PGN FFnnh	Proprietary-B (PDU2 broadcast); nn Group Extension (PS) configurable

Specifications	Excitation voltage	18 ... 36 V DC
	Excitation current	Typ. 20 mA for 24 V, max. 100 mA
	Measuring rate	1 kHz (asynchronous)
	Stability (temperature)	±50 x 10 ⁻⁶ / °C f.s.
	Repeatability	1 LSB
	Operating temperature	-40 ... +105 °C
	Protection	Reverse polarity, short circuit
	Dielectric strength	500 V (V AC, 50 Hz, 1 min.)
	EMC	EN 61326-1:2006

Signal wiring / connection	Signal name	Connector pin no.
	Shield	1
	Excitation +	2
	GND	3
	CAN-H	4
	CAN-L	5

View to sensor connector

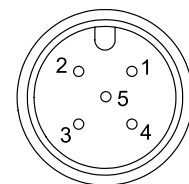

POSICHRON® Accessories Connector Cables



Connector cable for POSICHRON® position sensors
8 pin M12

The 8-lead shielded cable is supplied with a mating 8-pin 90° M12 connector at one end and 8 wires at the other end. Available lengths are 2, 5 and 10 m. Wire: cross sectional area 0.25 mm².

Order code:

KAB - XM - M12/8F/W - LITZE

IP69K: KAB - XM - M12/8F/W/69K - LITZE

Length in m

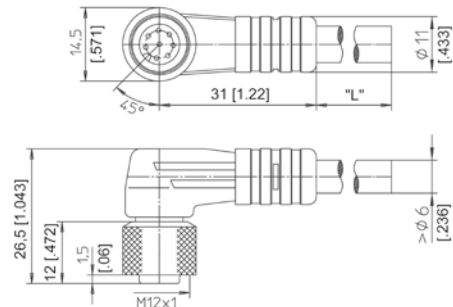

Connector cable for POSICHRON® position sensors
8 pin M12

The 8-lead shielded cable is supplied with a mating 8-pin M12 connector at one end and 8 wires at the other end. Available lengths are 2, 5 and 10 m. Wire: cross sectional area 0.25 mm².

Order code:

KAB - XM - M12/8F/G - LITZE

IP69K: KAB - XM - M12/8F/G/69K - LITZE

Length in m

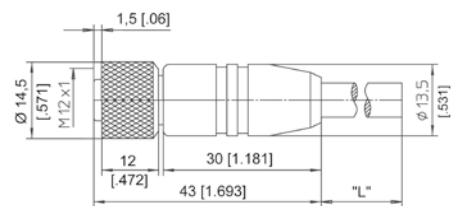

Connector cable wiring - M12, 8 pin

Connector pin / cable color

1	2	3	4	5	6	7	8
White	Brown	Green	Yellow	Grey	Pink	Blue	Red

Connector cable for POSICHRON® position sensors
4 pin M8

The 4-lead shielded cable is supplied with a mating 4-pin 90° M8 connector at one end and 4 wires at the other end. Available lengths are 2, 5 and 10 m. Wire: cross sectional area 0.14 mm².

Order code:

KAB - XM - M8/4F/W - LITZE

IP69K: KAB - XM - M8/4F/W/69K - LITZE

Length in m

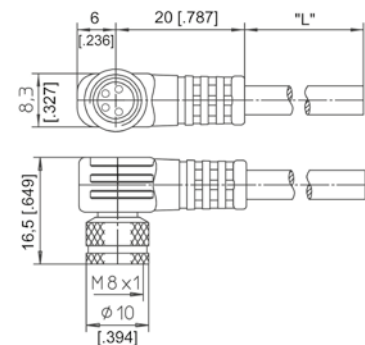

Connector cable for POSICHRON® position sensors
4 pin M8

The 4-lead shielded cable is supplied with a mating 4-pin M8 connector at one end and 4 wires at the other end. Available lengths are 2, 5 and 10 m. Wire: cross sectional area 0.14 mm².

Order code:

KAB - XM - M8/4F/G - LITZE

IP69K: KAB - XM - M8/4F/G/69K - LITZE

Length in m

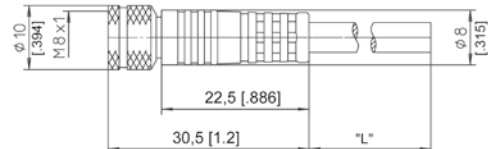

Connector cable wiring - M8, 4 pin

Connector pin / cable color

1	2	3	4
Brown	White	Blue	Black

POSICHRON® Accessories Connector Cables



**Connector/bus cable
for POSICHRON®
position sensors**
5 pin M12
CAN bus

The 5-lead shielded cable is supplied with a female 5-pin M12 connector at one end and a male 5-pin M12 connector at the other end. Available lengths are 0.3 m, 2 m, 5 m and 10 m.

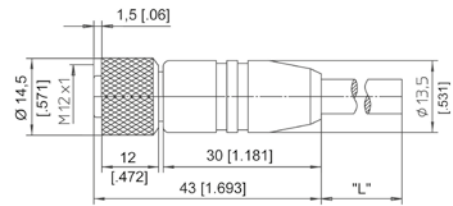

Order code:

KAB - XM - M12/5F/G - M12/5M/G - CAN

IP69K: KAB - XM - M12/5F/G/69K - M12/5M/G/69K - CAN

Length in m ↑

T-piece for bus cable
5 pin M12
CAN bus

KAB - TCONN - M12/5M - 2M12/5F - CAN

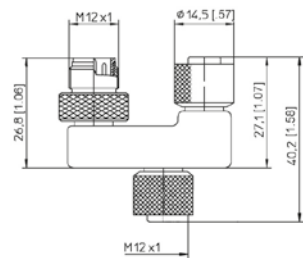

**Terminating
resistance**
5 pin M12
CAN bus

KAB - RTERM - M12/5M/G - CAN

