

# Flush Silhouette

LW Series Control Units



L6/A6 Series Accessories



# Add Style to Your Panel



## LW Series Flush Silhouette Control Units

Shape	Bezel Size	Bezel Material	Panel Cut-out	Lens Type	Pushbutton	Pilot Light	Illuminated Pushbutton	Selector	Key Selector	Illuminated Selector
	ø28	Metal	ø25.3	Flush	<input type="checkbox"/>	<input type="checkbox"/>	<input type="checkbox"/>	<input type="checkbox"/>	<input type="checkbox"/>	<input type="checkbox"/>
				Extended	<input type="checkbox"/>	<input type="checkbox"/>	<input type="checkbox"/>	<input type="checkbox"/>	<input type="checkbox"/>	<input type="checkbox"/>
	ø28	Plastic	ø25.3	Flush	<input type="checkbox"/>	<input type="checkbox"/>	<input type="checkbox"/>	<input type="checkbox"/>	<input type="checkbox"/>	<input type="checkbox"/>
				Extended	<input type="checkbox"/>	<input type="checkbox"/>	<input type="checkbox"/>	<input type="checkbox"/>	<input type="checkbox"/>	<input type="checkbox"/>
	□28	Plastic	□24.5	Flush	<input type="checkbox"/> *	<input type="checkbox"/>	<input type="checkbox"/> *	<input type="checkbox"/>	<input type="checkbox"/>	<input type="checkbox"/>
				Extended	<input type="checkbox"/>	<input type="checkbox"/>	<input type="checkbox"/>	<input type="checkbox"/>	<input type="checkbox"/>	<input type="checkbox"/>





\* Square switch guards available

Flush Silhouette is an IDEC trademark for control units with flush bezels.

# Slimmer than Ever



## L6/A6 Series Flush Silhouette Bezels

Shape	Bezel Size	Bezel Material	Panel Cut-out	Series	Pushbutton	Pilot Light	Illuminated Pushbutton	Selector	Key Selector	Illuminated Selector	Others
	ø24	Metal	ø20.2	L6 (Separate Type)	●	●	●	●	●	●	● (Lever)
				A6 (Unibody Type)	●	●	●	●	●	●	●
	ø24	Plastic	ø20.2	L6 (Separate Type)	●	●	●	●	●	●	● (Lever)
				A6 (Unibody Type)	●	●	●	●	●	●	●
	□24	Plastic	□20.2	L6 (Separate Type)	●	●	●	●	●	●	●
				A6 (Unibody Type)	●	●	●	●	●	●	●
	24 x 30	Plastic	20.2 x 26.2	L6 (Separate Type)	●	●	●	●	●	●	● (Buzzer)
				A6 (Unibody Type)	●	●	●	●	●	●	●





Note: For the L6 and A6 series, flush silhouette bezels are ordered separately to be combined with control units.

# Flush Silhouette LW Series Control Units

## Flush bezel projects only 2 mm from front of panel

ø28 round and 28-mm square black plastic bezels. Round metallic bezels are also available.

- ø25.3-mm round panel cut-out, 24.5-mm square panel cut-out.
- Collective mounting is possible.
- Pushbuttons, pilot lights, illuminated pushbuttons, selector switches, key selector switches, and illuminated selector switches are available. Square pushbuttons also available with switchguards.
- Key selector switches with high-security lock mechanism. Over 60 different key variations available to choose from.
- Separate type control units with a locking lever enable easy installation even when mounted collectively.
- Gold (gold-clad silver) or silver contacts.
- Degree of protection: IP65 (IEC 60529)
- UL recognized and CSA certified. EN compliant.

Safety Standards		File No. or Organization
UL		UL Recognition File No. E55996
CSA		166730 (LR21451)
EN	EN60947-1 EN60947-5-1	 TÜV Rheinland
		 EC Low Voltage Directive

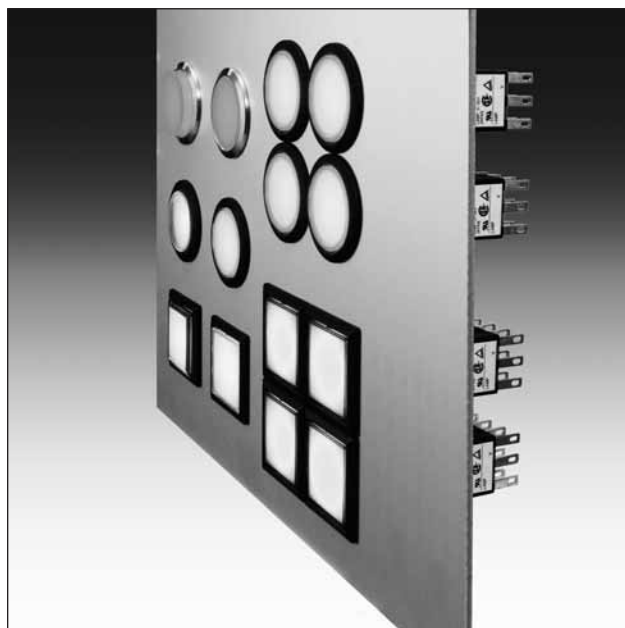

## Specifications and Ratings

### Contact Ratings

#### • Gold Contacts

Maximum Voltage	250V AC/DC	
Thermal Current	3A	
Operating Voltage	125V AC	30V DC
Operating Current (resistive load)	0.1A	0.1A
Contact Material	Gold-clad silver	

Minimum applicable load (reference value): 5V AC/DC, 1 mA  
(Applicable range is subject to the operating conditions and load.)

#### • Silver Contacts

Operating Voltage		30V	125V	250V	
Operating Current	AC 50/60Hz	Resistive Load	–	3A 2A	
		Inductive Load	–	2A 1.5A	
	DC	Resistive Load	2A	0.4A	–
		Inductive Load	1A	0.2A	–
Thermal Current		5A			
Contact Material		Silver			

AC inductive load: PF = 0.6 to 0.7

DC inductive load: L/R = 7 ms max.

### Specifications

Operating Temperature	–25 to +60°C (no freezing) Illuminated units: –25 to +50°C	
Storage Temperature	–40 to +80°	
Operating Humidity	45 to 85% RH (no condensation)	
Contact Resistance	50 mΩ maximum (initial value)	
Insulation Resistance	100 MΩ minimum (500V DC megger)	
Dielectric Strength	Switch Unit	Between live part and ground: 2,500V AC, 1 minute Between terminals of different poles: 2,500V AC, 1 minute Between terminals of the same poles: 1,000V AC, 1 minute
	Illumination Unit	Between live part and ground: 2,500V AC, 1 minute
Vibration Resistance	Operating extremes: 5 to 55 Hz, amplitude 0.5 mm	
Shock Resistance	Damage limits: 1,000 m/s <sup>2</sup> (100G) Operating extremes: 100 m/s <sup>2</sup> (10G)	
Mechanical Life (minimum operations)	Momentary:	1,000,000
	Maintained:	500,000
	Selector switches:	250,000
	Key selector switches: Illuminated selector switches:	100,000 250,000
Electrical Life (minimum operations)	Momentary:	100,000 (*1)
	Maintained:	100,000 (*2)
	Selector switches:	100,000 (*2)
	Key selector switches:	100,000 (*2)
	Illuminated selector switches:	100,000 (*2)
*1 Switching frequency 1,800 operations/h		
*2 Switching frequency 900 operations/h		
Degree of Protection	IP65 (IEC 60529)	
Terminal Style	Solder/tab terminal #110 PC board terminal Screw terminal	

## LED Lamp Ratings (LSTD Type)

Type No.		LSTD-6②	LSTD-1②	LSTD-2②
Lamp Base		BA9S/13		
Rated Voltage		6V AC/DC	12V AC/DC	24V AC/DC
Voltage Range		6V AC/DC ±10%	12V AC/DC ±10%	24V AC/DC ±10%
Current Draw	AC	A, R, W, Y: 17 mA G, S: 8 mA	11 mA	11 mA
	DC	A, R, W, Y: 14 mA G, S: 5.5 mA	10 mA	10 mA
Color Code ②		A (amber), G (green), R (red), S (blue), W (white), Y (yellow)		
Lamp Base Color		Same as illumination color		
Voltage Marking		Die stamped on the base		
Life (reference value)		Approx. 50,000 hours (The luminance is reduced to 50% the initial intensity when used on complete DC.)		
Internal Circuit	A, R, W, Y			
	G, S			
		LED Chip Protection Diode Zener Diode		

### Mounting Hole Layout

#### • Round Type

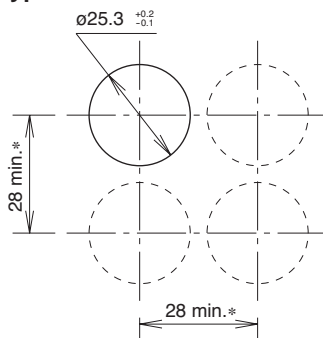

#### • Square Type

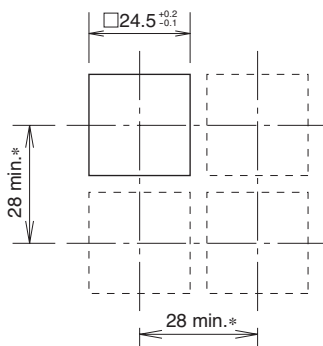

Note: Determine mounting centers to ensure easy operation.

- \*Pushbutton with switch guard: Vertical 56.5 mm  
Horizontal 28 mm minimum
- \*Lever operator type selector switches: Vertical 31 mm  
Horizontal 28 mm minimum
- \*Screw terminal type: Vertical 40 mm  
Horizontal 28 mm minimum





### Ordering Information

#### Standard Units

- Specify a button or lens color code in the Type No.
- All illuminated units are supplied with an LED lamp.
- All standard units are UL recognized, CSA certified, and EN compliant (TÜV Rheinland).





# Flush Silhouette LW Series Pushbuttons

## Round Pushbuttons with Metal Bezel

Shape	Operation Type	Contact Material	Contact	Type No.			① Button Color Code
				Solder/Tab Terminal	PC Board Terminal	Screw Terminal	
Round Flush with Metal Bezel LW6MB-M1 LW6MB-A1    	Momentary	Gold	SPDT	LW6MB-M1C1①	LW6MB-M1C1V①	–	Specify a button color code in place of ① in the Type No.  LA: amber LB: black LG: green LR: red LS: blue LW: white LY: yellow
			DPDT	LW6MB-M1C2①	LW6MB-M1C2V①	LW6MB-M1C2M①	
			3PDT	LW6MB-M1C3①	LW6MB-M1C3V①	–	
		Silver	SPDT	LW6MB-M1C5①	–	–	
			DPDT	LW6MB-M1C6①	–	LW6MB-M1C6M①	
			3PDT	LW6MB-M1C7①	–	–	
	Maintained	Gold	SPDT	LW6MB-A1C1①	LW6MB-A1C1V①	–	
			DPDT	LW6MB-A1C2①	LW6MB-A1C2V①	LW6MB-A1C2M①	
			3PDT	LW6MB-A1C3①	LW6MB-A1C3V①	–	
		Silver	SPDT	LW6MB-A1C5①	–	–	
			DPDT	LW6MB-A1C6①	–	LW6MB-A1C6M①	
			3PDT	LW6MB-A1C7①	–	–	
Round Extended with Metal Bezel LW6MB-M2 LW6MB-A2    	Momentary	Gold	SPDT	LW6MB-M2C1①	LW6MB-M2C1V①	–	
			DPDT	LW6MB-M2C2①	LW6MB-M2C2V①	LW6MB-M2C2M①	
			3PDT	LW6MB-M2C3①	LW6MB-M2C3V①	–	
		Silver	SPDT	LW6MB-M2C5①	–	–	
			DPDT	LW6MB-M2C6①	–	LW6MB-M2C6M①	
			3PDT	LW6MB-M2C7①	–	–	
	Maintained	Gold	SPDT	LW6MB-A2C1①	LW6MB-A2C1V①	–	
			DPDT	LW6MB-A2C2①	LW6MB-A2C2V①	LW6MB-A2C2M①	
			3PDT	LW6MB-A2C3①	LW6MB-A2C3V①	–	
		Silver	SPDT	LW6MB-A2C5①	–	–	
			DPDT	LW6MB-A2C6①	–	LW6MB-A2C6M①	
			3PDT	LW6MB-A2C7①	–	–	





• Lenses for illuminated pushbuttons are used for flush silhouette pushbuttons.

## Round / Square Pushbuttons with Black Plastic Bezel

Shape	Operation Type	Contact Material	Contact	Type No.			① Button Color Code
				Solder/Tab Terminal	PC Board Terminal	Screw Terminal	
Round Flush with Black Plastic Bezel LW6B-M1 LW6B-A1    	Momentary	Gold	SPDT	LW6B-M1C1①	LW6B-M1C1V①	–	Specify a button color code in place of ① in the Type No.  LA: amber LB: black LG: green LR: red LW: white LY: yellow
			DPDT	LW6B-M1C2①	LW6B-M1C2V①	LW6B-M1C2M①	
			3PDT	LW6B-M1C3①	LW6B-M1C3V①	–	
		Silver	SPDT	LW6B-M1C5①	–	–	
			DPDT	LW6B-M1C6①	–	LW6B-M1C6M①	
			3PDT	LW6B-M1C7①	–	–	
	Maintained	Gold	SPDT	LW6B-A1C1①	LW6B-A1C1V①	–	
			DPDT	LW6B-A1C2①	LW6B-A1C2V①	LW6B-A1C2M①	
			3PDT	LW6B-A1C3①	LW6B-A1C3V①	–	
		Silver	SPDT	LW6B-A1C5①	–	–	
			DPDT	LW6B-A1C6①	–	LW6B-A1C6M①	
			3PDT	LW6B-A1C7①	–	–	
Round Extended with Black Plastic Bezel LW6B-M2 LW6B-A2    	Momentary	Gold	SPDT	LW6B-M2C1①	LW6B-M2C1V①	–	
			DPDT	LW6B-M2C2①	LW6B-M2C2V①	LW6B-M2C2M①	
			3PDT	LW6B-M2C3①	LW6B-M2C3V①	–	
		Silver	SPDT	LW6B-M2C5①	–	–	
			DPDT	LW6B-M2C6①	–	LW6B-M2C6M①	
			3PDT	LW6B-M2C7①	–	–	
	Maintained	Gold	SPDT	LW6B-A2C1①	LW6B-A2C1V①	–	
			DPDT	LW6B-A2C2①	LW6B-A2C2V①	LW6B-A2C2M①	
			3PDT	LW6B-A2C3①	LW6B-A2C3V①	–	
		Silver	SPDT	LW6B-A2C5①	–	–	
			DPDT	LW6B-A2C6①	–	LW6B-A2C6M①	
			3PDT	LW6B-A2C7①	–	–	

• Lenses for illuminated pushbuttons are used for flush silhouette pushbuttons.

# Flush Silhouette LW Series Pushbuttons

Shape	Operation Type	Contact Material	Contact	Type No.			① Button Color Code	
				Solder/Tab Terminal	PC Board Terminal	Screw Terminal		
Square Flush with Black Plastic Bezel LW7B-M1 LW7B-A1  	Momentary	Gold	SPDT	LW7B-M1C1①	LW7B-M1C1V①	-	Specify a button color code in place of ① in the Type No.  LA: amber LB: black LG: green LR: red LS: blue LW: white LY: yellow	
			DPDT	LW7B-M1C2①	LW7B-M1C2V①	LW7B-M1C2M①		
			3PDT	LW7B-M1C3①	LW7B-M1C3V①	-		
		Silver	SPDT	LW7B-M1C5①	-	-		
			DPDT	LW7B-M1C6①	-	LW7B-M1C6M①		
			3PDT	LW7B-M1C7①	-	-		
			Maintained	Gold	SPDT	LW7B-A1C1①		LW7B-A1C1V①
	DPDT	LW7B-A1C2①			LW7B-A1C2V①	LW7B-A1C2M①		
	3PDT	LW7B-A1C3①			LW7B-A1C3V①	-		
	Silver	SPDT		LW7B-A1C5①	-	-		
		DPDT		LW7B-A1C6①	-	LW7B-A1C6M①		
		3PDT		LW7B-A1C7①	-	-		
		Square Flush Guard Type with Black Plastic Bezel LW7GB-M1 LW7GB-A1  		Momentary	Gold	SPDT		LW7GB-M1C1①
	DPDT		LW7GB-M1C2①			LW7GB-M1C2V①		LW7GB-M1C2M①
3PDT	LW7GB-M1C3①		LW7GB-M1C3V①			-		
Silver	SPDT		LW7GB-M1C5①		-	-		
	DPDT		LW7GB-M1C6①		-	LW7GB-M1C6M①		
	3PDT		LW7GB-M1C7①		-	-		
	Maintained		Gold		SPDT	LW7GB-A1C1①	LW7GB-A1C1V①	-
DPDT				LW7GB-A1C2①	LW7GB-A1C2V①	LW7GB-A1C2M①		
3PDT				LW7GB-A1C3①	LW7GB-A1C3V①	-		
Silver			SPDT	LW7GB-A1C5①	-	-		
			DPDT	LW7GB-A1C6①	-	LW7GB-A1C6M①		
			3PDT	LW7GB-A1C7①	-	-		

• Lenses for illuminated pushbuttons are used for flush silhouette pushbuttons.

## Dimensions

### • Round/Square

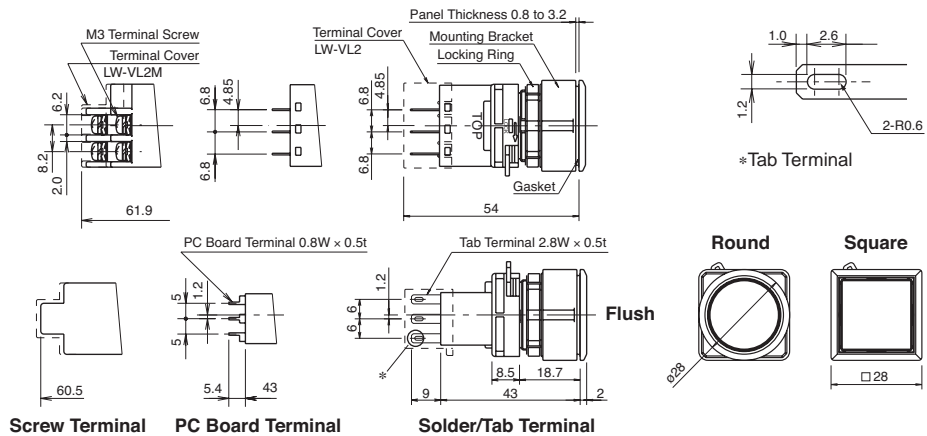

### • Square Flush Guard Type

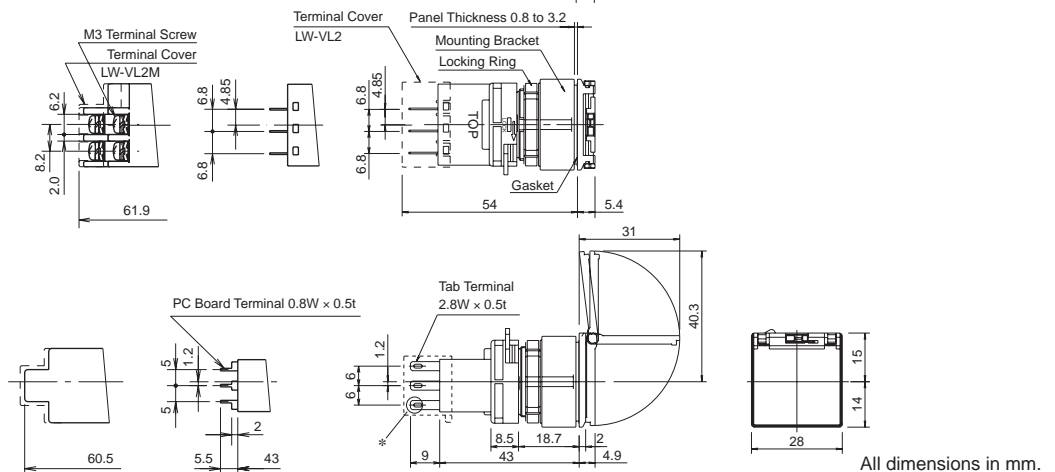

# Flush Silhouette LW Series Pushbuttons

## Bottom View

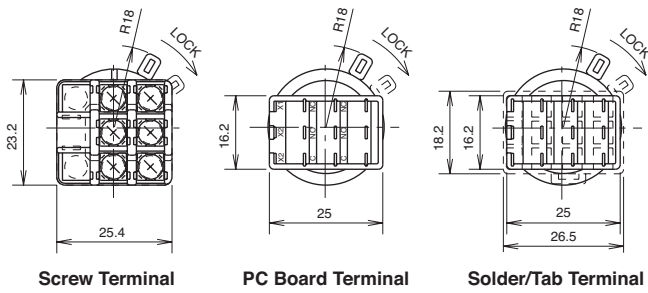

## Terminal Arrangement (Bottom View)

### • Solder/Tab Terminal

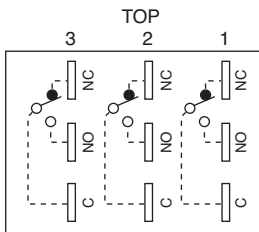

Note: SPDT has C, NO, and NC only in the center. DPDT has C, NO, and NC only on the right and left. Screw terminal type is only available in DPDT configuration.

### • Screw Terminal

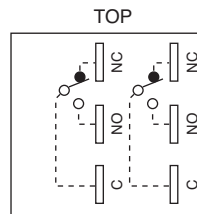

## PC Board Drilling Layout (Bottom View)

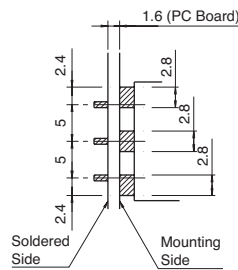
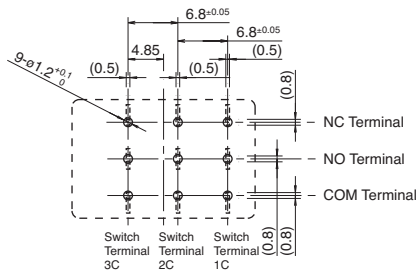













Note the pattern of the PC board as the terminals on the mounting surface are 2.8 mm wide.

All dimensions in mm.



# Flush Silhouette LW Series Pilot Lights

## Round / Square Pilot Lights with Metal Bezel and Black Plastic Bezel

Shape	Lamp	Input Type	Type No			② Lens Color Code
			Solder/Tab Terminal (Unibody Type)	PC Board Terminal (Separate Type)	Screw Terminal (Unibody Type)	
Round Flush with Metal Bezel LW6MP-1  	LED	6V AC/DC ±10%	LW6MP-12②	LW6MP-1C02V②	LW6MP-12M②	Specify a lens color code in place of ② in the Type No.  A: amber G: green R: red S: blue W: white Y: yellow
		12V AC/DC ±10%	LW6MP-13②	LW6MP-1C03V②	LW6MP-13M②	
		24V AC/DC ±10%	LW6MP-14②	LW6MP-1C04V②	LW6MP-14M②	
Round Extended with Metal Bezel LW6MP-2  	LED	6V AC/DC ±10%	LW6MP-22②	LW6MP-2C02V②	LW6MP-22M②	
		12V AC/DC ±10%	LW6MP-23②	LW6MP-2C03V②	LW6MP-23M②	
		24V AC/DC ±10%	LW6MP-24②	LW6MP-2C04V②	LW6MP-24M②	
Round Flush with Black Plastic Bezel LW6P-1  	LED	6V AC/DC ±10%	LW6P-12②	LW6P-1C02V②	LW6P-12M②	
		12V AC/DC ±10%	LW6P-13②	LW6P-1C03V②	LW6P-13M②	
		24V AC/DC ±10%	LW6P-14②	LW6P-1C04V②	LW6P-14M②	
Round Extended with Black Plastic Bezel LW6P-2  	LED	6V AC/DC ±10%	LW6P-22②	LW6P-2C02V②	LW6P-22M②	
		12V AC/DC ±10%	LW6P-23②	LW6P-2C03V②	LW6P-23M②	
		24V AC/DC ±10%	LW6P-24②	LW6P-2C04V②	LW6P-24M②	
Square Flush with Black Plastic Bezel LW7P-1  	LED	6V AC/DC ±10%	LW7P-12②	LW7P-1C02V②	LW7P-12M②	
		12V AC/DC ±10%	LW7P-13②	LW7P-1C03V②	LW7P-13M②	
		24V AC/DC ±10%	LW7P-14②	LW7P-1C04V②	LW7P-14M②	
Square Extended with Black Plastic Bezel LW7P-2  	LED	6V AC/DC ±10%	LW7P-22②	LW7P-2C02V②	LW7P-22M②	
		12V AC/DC ±10%	LW7P-23②	LW7P-2C03V②	LW7P-23M②	
		24V AC/DC ±10%	LW7P-24②	LW7P-2C04V②	LW7P-24M②	

• Every pilot light contains an LED lamp (LSTD) of the specified color and voltage.

# Flush Silhouette LW Series Pilot Lights

## Dimensions

### • Unibody Type

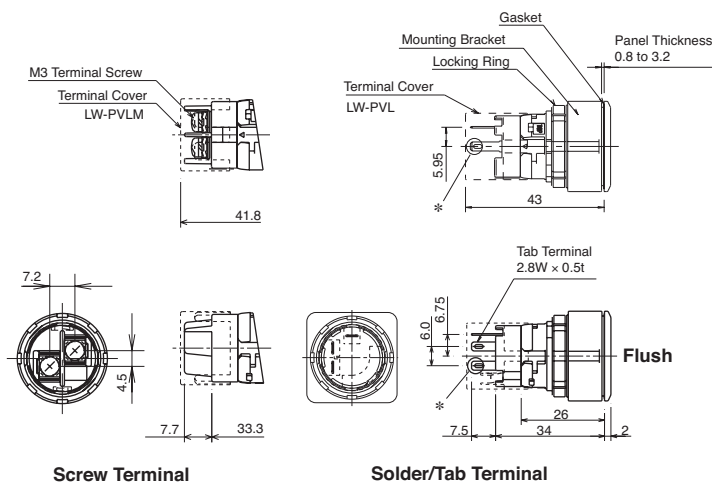

Screw Terminal

Solder/Tab Terminal

### • Separate Type

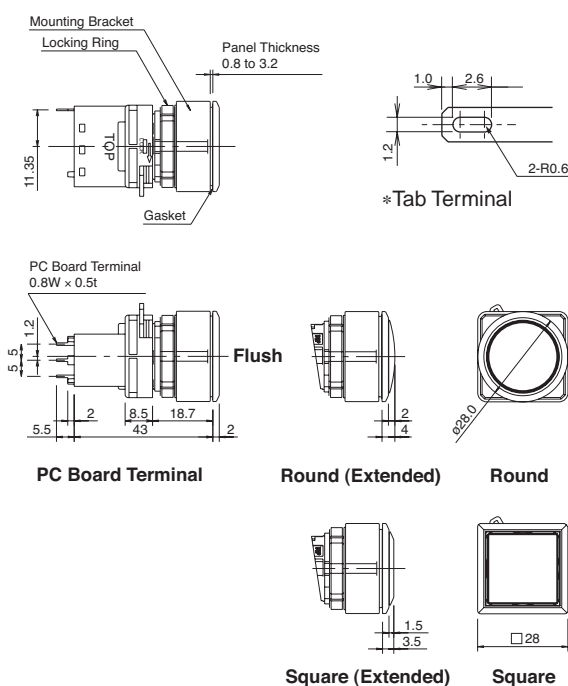

PC Board Terminal

Round (Extended)

Round

Square (Extended)

Square

## Terminal Arrangement (Bottom View)

### • Unibody Type

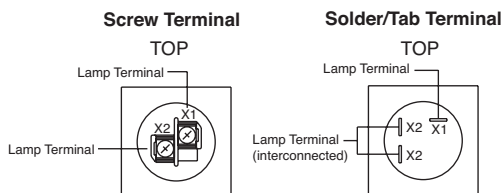

• Lamp terminals do not have any polarity.

### • Separate Type

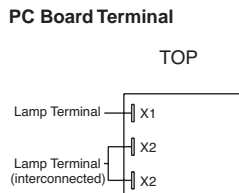

• Lamp terminals do not have any polarity.

## PC Board Drilling Layout (Bottom View)

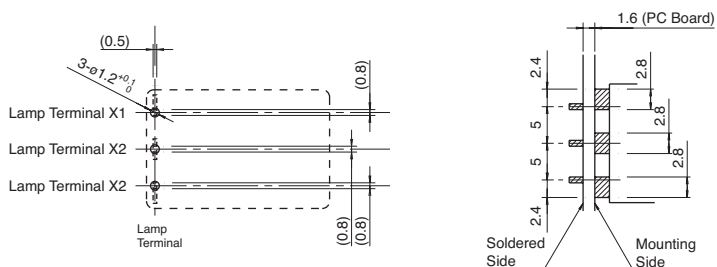

Note the pattern of the PC board as the terminals on the mounting surface are 2.8 mm wide.

All dimensions in mm.

# Flush Silhouette LW Series Illuminated Pushbuttons

## Round Illuminated Pushbuttons with Metal Bezel

Shape	Lamp	Operation	Contact Material	Contact	Type No.		
					Solder/Tab Terminal	PC Board Terminal	Screw Terminal
Round Flush with Metal Bezel LW6ML-M1 LW6ML-A1  	LED	Momentary	Gold	SPDT	LW6ML-M1C1③②	LW6ML-M1C1③V②	—
				DPDT	LW6ML-M1C2③②	LW6ML-M1C2③V②	LW6ML-M1C2③M②
				3PDT	LW6ML-M1C3③②	LW6ML-M1C3③V②	—
			Silver	SPDT	LW6ML-M1C5③②	—	—
				DPDT	LW6ML-M1C6③②	—	LW6ML-M1C6③M②
				3PDT	LW6ML-M1C7③②	—	—
		Maintained	Gold	SPDT	LW6ML-A1C1③②	LW6ML-A1C1③V②	—
				DPDT	LW6ML-A1C2③②	LW6ML-A1C2③V②	LW6ML-A1C2③M②
				3PDT	LW6ML-A1C3③②	LW6ML-A1C3③V②	—
			Silver	SPDT	LW6ML-A1C5③②	—	—
				DPDT	LW6ML-A1C6③②	—	LW6ML-A1C6③M②
				3PDT	LW6ML-A1C7③②	—	—

### • Color Code and Voltage Code

② Lens/LED Color Code	③ Operating Voltage Code
Specify a Lens/LED color code in place of ② in the Type No. A: amber G: green R: red S: blue W: white Y: yellow	Specify an operating voltage code in place of ③ in the Type No. 2: 6V AC/DC 3: 12V AC/DC 4: 24V AC/DC

• Every illuminated pushbutton contains an LED lamp (LSTD) of the specified color and voltage.

## Round / Square Illuminated Pushbuttons with Black Plastic Bezel

Shape	Lamp	Operation	Contact Material	Contact	Type No.		
					Solder/Tab Terminal	PC Board Terminal	Screw Terminal
Round Flush with Black Plastic Bezel LW6L-M1 LW6L-A1  	LED	Momentary	Gold	SPDT	LW6L-M1C1③②	LW6L-M1C1③V②	—
				DPDT	LW6L-M1C2③②	LW6L-M1C2③V②	LW6L-M1C2③M②
				3PDT	LW6L-M1C3③②	LW6L-M1C3③V②	—
			Silver	SPDT	LW6L-M1C5③②	—	—
				DPDT	LW6L-M1C6③②	—	LW6L-M1C6③M②
				3PDT	LW6L-M1C7③②	—	—
		Maintained	Gold	SPDT	LW6L-A1C1③②	LW6L-A1C1③V②	—
				DPDT	LW6L-A1C2③②	LW6L-A1C2③V②	LW6L-A1C2③M②
				3PDT	LW6L-A1C3③②	LW6L-A1C3③V②	—
			Silver	SPDT	LW6L-A1C5③②	—	—
				DPDT	LW6L-A1C6③②	—	LW6L-A1C6③M②
				3PDT	LW6L-A1C7③②	—	—

# Flush Silhouette LW Series Illuminated Pushbuttons

Shape	Lamp	Operation	Contact Material	Contact	Type No.					
					Solder/Tab Terminal	PC Board Terminal	Screw Terminal			
Round Extended with Black Plastic Bezel LW6L-M2 LW6L-A2  	LED	Momentary	Gold	SPDT	LW6L-M2C1③②	LW6L-M2C1③V②	-			
				DPDT	LW6L-M2C2③②	LW6L-M2C2③V②	LW6L-M2C2③M②			
				3PDT	LW6L-M2C3③②	LW6L-M2C3③V②	-			
			Silver	SPDT	LW6L-M2C5③②	-	-			
				DPDT	LW6L-M2C6③②	-	LW6L-M2C6③M②			
				3PDT	LW6L-M2C7③②	-	-			
		Maintained	Gold	SPDT	LW6L-A2C1③②	LW6L-A2C1③V②	-			
				DPDT	LW6L-A2C2③②	LW6L-A2C2③V②	LW6L-A2C2③M②			
				3PDT	LW6L-A2C3③②	LW6L-A2C3③V②	-			
			Silver	SPDT	LW6L-A2C5③②	-	-			
				DPDT	LW6L-A2C6③②	-	LW6L-A2C6③M②			
				3PDT	LW6L-A2C7③②	-	-			
			Square Flush with Black Plastic Bezel LW7L-M1 LW7L-A1  	LED	Momentary	Gold	SPDT	LW7L-M1C1③②	LW7L-M1C1③V②	-
							DPDT	LW7L-M1C2③②	LW7L-M1C2③V②	LW7L-M1C2③M②
							3PDT	LW7L-M1C3③②	LW7L-M1C3③V②	-
Silver	SPDT	LW7L-M1C5③②				-	-			
	DPDT	LW7L-M1C6③②				-	LW7L-M1C6③M②			
	3PDT	LW7L-M1C7③②				-	-			
Maintained	Gold	SPDT			LW7L-A1C1③②	LW7L-A1C1③V②	-			
		DPDT			LW7L-A1C2③②	LW7L-A1C2③V②	LW7L-A1C2③M②			
		3PDT			LW7L-A1C3③②	LW7L-A1C3③V②	-			
	Silver	SPDT			LW7L-A1C5③②	-	-			
		DPDT			LW7L-A1C6③②	-	LW7L-A1C6③M②			
		3PDT			LW7L-A1C7③②	-	-			
	Square Flush Guard Type with Black Plastic Bezel LW7GL-M1 LW7GL-A1  	LED			Momentary	Gold	SPDT	LW7GL-M1C1③②	LW7GL-M1C1③V②	-
							DPDT	LW7GL-M1C2③②	LW7GL-M1C2③V②	LW7GL-M1C2③M②
							3PDT	LW7GL-M1C3③②	LW7GL-M1C3③V②	-
Silver			SPDT	LW7GL-M1C5③②		-	-			
			DPDT	LW7GL-M1C6③②		-	LW7GL-M1C6③M②			
			3PDT	LW7GL-M1C7③②		-	-			
Maintained			Gold	SPDT	LW7GL-A1C1③②	LW7GL-A1C1③V②	-			
				DPDT	LW7GL-A1C2③②	LW7GL-A1C2③V②	LW7GL-A1C2③M②			
				3PDT	LW7GL-A1C3③②	LW7GL-A1C3③V②	-			
			Silver	SPDT	LW7GL-A1C5③②	-	-			
				DPDT	LW7GL-A1C6③②	-	LW7GL-A1C6③M②			
				3PDT	LW7GL-A1C7③②	-	-			

## • Color Code and Voltage Code

② Lens/LED Color Code	③ Operating Voltage Code
Specify a Lens/LED color code in place of ② in the Type No. A: amber G: green R: red S: blue W: white Y: yellow	Specify an operating voltage code in place of ③ in the Type No. 2: 6V AC/DC 3: 12V AC/DC 4: 24V AC/DC

• Every illuminated pushbutton contains an LED lamp (LSTD) of the specified color and voltage.

## PC Board Drilling Layout (Bottom View)

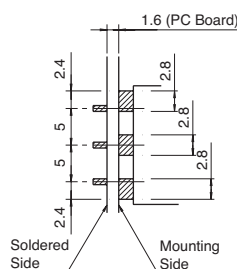
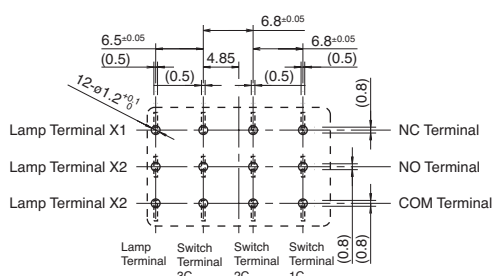

Note the pattern of the PC board as the terminals on the mounting surface are 2.8 mm wide.

# Flush Silhouette LW Series Illuminated Pushbuttons

## Dimensions

### • Round/Square

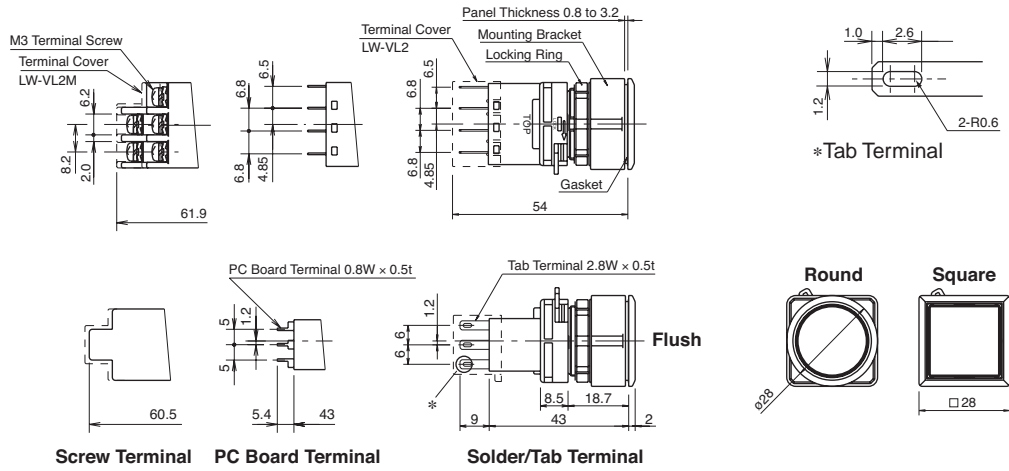

### • Square Switch Guard

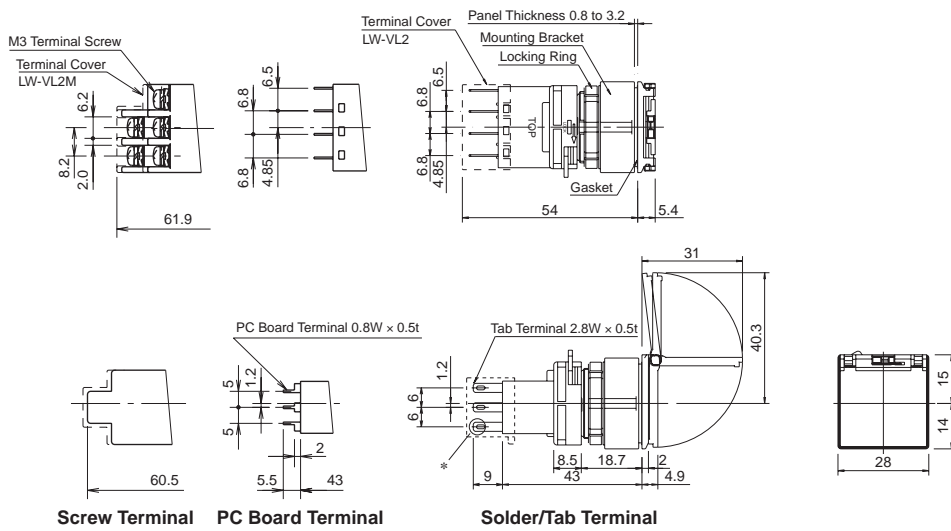

## Bottom View

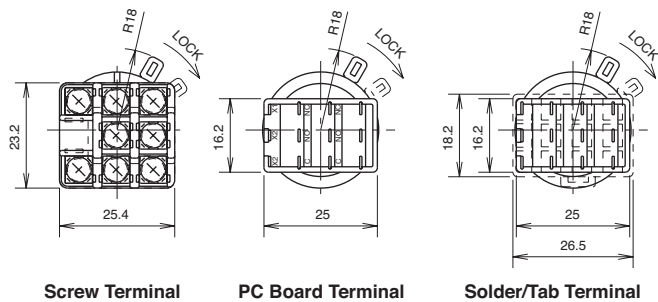

## Terminal Arrangement (Bottom View)

### Solder/Tab Terminal

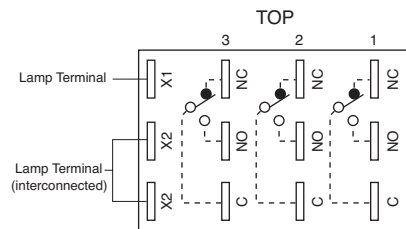

Note: SPDT has C, NO, and NC only in the center. DPDT has C, NO, and NC only on the right and left. Lamp terminals do not have any polarity.



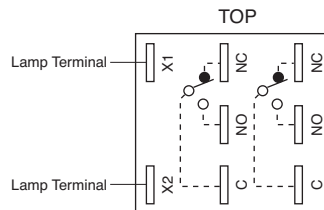











### Screw Terminal



All dimensions in mm.

# Flush Silhouette LW Series Selector Switches















## Selector Switches with Round Metal Bezel

Shape	Operation Type	Position	Contact Material	Contact	Type No.		
					Solder/Tab Terminal	PC Board Terminal	Screw Terminal
Round Metal Bezel LW6MS (Knob Operator)    RU SF A CE	90° 2-position Maintained		Gold	SPDT	LW6MS-2C1	LW6MS-2C1V	—
				DPDT	LW6MS-2C2	LW6MS-2C2V	LW6MS-2C2M
				3PDT	LW6MS-2C3	LW6MS-2C3V	—
			Silver	SPDT	LW6MS-2C5	—	—
				DPDT	LW6MS-2C6	—	LW6MS-2C6M
				3PDT	LW6MS-2C7	—	—
	90° 2-position Spring Return from Right		Gold	SPDT	LW6MS-21C1	LW6MS-21C1V	—
				DPDT	LW6MS-21C2	LW6MS-21C2V	LW6MS-21C2M
				3PDT	LW6MS-21C3	LW6MS-21C3V	—
			Silver	SPDT	LW6MS-21C5	—	—
				DPDT	LW6MS-21C6	—	LW6MS-21C6M
				3PDT	LW6MS-21C7	—	—
	45° 3-position Maintained		Gold	DPDT	LW6MS-3C2	LW6MS-3C2V	LW6MS-3C2M
				3PDT	LW6MS-3C3	LW6MS-3C3V	—
				3PDT	LW6MS-3C7	—	—
			Silver	DPDT	LW6MS-3C6	—	LW6MS-3C6M
				3PDT	LW6MS-3C7	—	—
				3PDT	LW6MS-3C7	—	—
	45° 3-position Spring Return from Right		Gold	DPDT	LW6MS-31C2	LW6MS-31C2V	LW6MS-31C2M
				3PDT	LW6MS-31C3	LW6MS-31C3V	—
				3PDT	LW6MS-31C7	—	—
			Silver	DPDT	LW6MS-31C6	—	LW6MS-31C6M
				3PDT	LW6MS-31C7	—	—
				3PDT	LW6MS-31C7	—	—
45° 3-position Spring Return from Left		Gold	DPDT	LW6MS-32C2	LW6MS-32C2V	LW6MS-32C2M	
			3PDT	LW6MS-32C3	LW6MS-32C3V	—	
			3PDT	LW6MS-32C7	—	—	
		Silver	DPDT	LW6MS-32C6	—	LW6MS-32C6M	
			3PDT	LW6MS-32C7	—	—	
			3PDT	LW6MS-32C7	—	—	
45° 3-position Spring Return Two-way		Gold	DPDT	LW6MS-33C2	LW6MS-33C2V	LW6MS-33C2M	
			3PDT	LW6MS-33C3	LW6MS-33C3V	—	
			3PDT	LW6MS-33C7	—	—	
		Silver	DPDT	LW6MS-33C6	—	LW6MS-33C6M	
			3PDT	LW6MS-33C7	—	—	
			3PDT	LW6MS-33C7	—	—	
Round Metal Bezel LW6MS (Lever Operator)    RU SF A CE	90° 2-position Maintained		Gold	SPDT	LW6MS-2LC1	LW6MS-2LC1V	—
				DPDT	LW6MS-2LC2	LW6MS-2LC2V	LW6MS-2LC2M
				3PDT	LW6MS-2LC3	LW6MS-2LC3V	—
			Silver	SPDT	LW6MS-2LC5	—	—
				DPDT	LW6MS-2LC6	—	LW6MS-2LC6M
				3PDT	LW6MS-2LC7	—	—
	90° 2-position Spring Return from Right		Gold	SPDT	LW6MS-21LC1	LW6MS-21LC1V	—
				DPDT	LW6MS-21LC2	LW6MS-21LC2V	LW6MS-21LC2M
				3PDT	LW6MS-21LC3	LW6MS-21LC3V	—
			Silver	SPDT	LW6MS-21LC5	—	—
				DPDT	LW6MS-21LC6	—	LW6MS-21LC6M
				3PDT	LW6MS-21LC7	—	—
	45° 3-position Maintained		Gold	DPDT	LW6MS-3LC2	LW6MS-3LC2V	LW6MS-3LC2M
				3PDT	LW6MS-3LC3	LW6MS-3LC3V	—
				3PDT	LW6MS-3LC7	—	—
			Silver	DPDT	LW6MS-3LC6	—	LW6MS-3LC6M
				3PDT	LW6MS-3LC7	—	—
				3PDT	LW6MS-3LC7	—	—
	45° 3-position Spring Return from Right		Gold	DPDT	LW6MS-31LC2	LW6MS-31LC2V	LW6MS-31LC2M
				3PDT	LW6MS-31LC3	LW6MS-31LC3V	—
				3PDT	LW6MS-31LC7	—	—
			Silver	DPDT	LW6MS-31LC6	—	LW6MS-31LC6M
				3PDT	LW6MS-31LC7	—	—
				3PDT	LW6MS-31LC7	—	—
45° 3-position Spring Return from Left		Gold	DPDT	LW6MS-32LC2	LW6MS-32LC2V	LW6MS-32LC2M	
			3PDT	LW6MS-32LC3	LW6MS-32LC3V	—	
			3PDT	LW6MS-32LC7	—	—	
		Silver	DPDT	LW6MS-32LC6	—	LW6MS-32LC6M	
			3PDT	LW6MS-32LC7	—	—	
			3PDT	LW6MS-32LC7	—	—	
45° 3-position Spring Return Two-way		Gold	DPDT	LW6MS-33LC2	LW6MS-33LC2V	LW6MS-33LC2M	
			3PDT	LW6MS-33LC3	LW6MS-33LC3V	—	
			3PDT	LW6MS-33LC7	—	—	
		Silver	DPDT	LW6MS-33LC6	—	LW6MS-33LC6M	
			3PDT	LW6MS-33LC7	—	—	
			3PDT	LW6MS-33LC7	—	—	

• For contact operation and dimensions, see page 17.

# Flush Silhouette LW Series Selector Switches















## Selector Switches with Round Black Plastic Bezel

Shape	Operation Type	Position	Contact Material	Contact	Type No.		
					Solder/Tab Terminal	PC Board Terminal	Screw Terminal
Round Black Plastic Bezel LW6S (Knob Operator)    RU SF A CE	90° 2-position Maintained		Gold	SPDT	LW6S-2C1	LW6S-2C1V	—
				DPDT	LW6S-2C2	LW6S-2C2V	LW6S-2C2M
				3PDT	LW6S-2C3	LW6S-2C3V	—
			Silver	SPDT	LW6S-2C5	—	—
				DPDT	LW6S-2C6	—	LW6S-2C6M
				3PDT	LW6S-2C7	—	—
	90° 2-position Spring Return from Right		Gold	SPDT	LW6S-21C1	LW6S-21C1V	—
				DPDT	LW6S-21C2	LW6S-21C2V	LW6S-21C2M
				3PDT	LW6S-21C3	LW6S-21C3V	—
			Silver	SPDT	LW6S-21C5	—	—
				DPDT	LW6S-21C6	—	LW6S-21C6M
				3PDT	LW6S-21C7	—	—
	45° 3-position Maintained		Gold	DPDT	LW6S-3C2	LW6S-3C2V	LW6S-3C2M
				3PDT	LW6S-3C3	LW6S-3C3V	—
			Silver	DPDT	LW6S-3C6	—	LW6S-3C6M
	3PDT	LW6S-3C7		—	—		
	45° 3-position Spring Return from Right		Gold	DPDT	LW6S-31C2	LW6S-31C2V	LW6S-31C2M
				3PDT	LW6S-31C3	LW6S-31C3V	—
			Silver	DPDT	LW6S-31C6	—	LW6S-31C6M
	3PDT	LW6S-31C7		—	—		
	45° 3-position Spring Return from Left		Gold	DPDT	LW6S-32C2	LW6S-32C2V	LW6S-32C2M
				3PDT	LW6S-32C3	LW6S-32C3V	—
			Silver	DPDT	LW6S-32C6	—	LW6S-32C6M
	3PDT	LW6S-32C7		—	—		
45° 3-position Spring Return Two-way		Gold	DPDT	LW6S-33C2	LW6S-33C2V	LW6S-33C2M	
			3PDT	LW6S-33C3	LW6S-33C3V	—	
		Silver	DPDT	LW6S-33C6	—	LW6S-33C6M	
3PDT	LW6S-33C7		—	—			
Round Black Plastic Bezel LW6S (Lever Operator)    RU SF A CE	90° 2-position Maintained		Gold	SPDT	LW6S-2LC1	LW6S-2LC1V	—
				DPDT	LW6S-2LC2	LW6S-2LC2V	LW6S-2LC2M
				3PDT	LW6S-2LC3	LW6S-2LC3V	—
			Silver	SPDT	LW6S-2LC5	—	—
				DPDT	LW6S-2LC6	—	LW6S-2LC6M
				3PDT	LW6S-2LC7	—	—
	90° 2-position Spring Return from Right		Gold	SPDT	LW6S-21LC1	LW6S-21LC1V	—
				DPDT	LW6S-21LC2	LW6S-21LC2V	LW6S-21LC2M
				3PDT	LW6S-21LC3	LW6S-21LC3V	—
			Silver	SPDT	LW6S-21LC5	—	—
				DPDT	LW6S-21LC6	—	LW6S-21LC6M
				3PDT	LW6S-21LC7	—	—
	45° 3-position Maintained		Gold	DPDT	LW6S-3LC2	LW6S-3LC2V	LW6S-3LC2M
				3PDT	LW6S-3LC3	LW6S-3LC3V	—
			Silver	DPDT	LW6S-3LC6	—	LW6S-3LC6M
	3PDT	LW6S-3LC7		—	—		
	45° 3-position Spring Return from Right		Gold	DPDT	LW6S-31LC2	LW6S-31LC2V	LW6S-31LC2M
				3PDT	LW6S-31LC3	LW6S-31LC3V	—
			Silver	DPDT	LW6S-31LC6	—	LW6S-31LC6M
	3PDT	LW6S-31LC7		—	—		
	45° 3-position Spring Return from Left		Gold	DPDT	LW6S-32LC2	LW6S-32LC2V	LW6S-32LC2M
				3PDT	LW6S-32LC3	LW6S-32LC3V	—
			Silver	DPDT	LW6S-32LC6	—	LW6S-32LC6M
	3PDT	LW6S-32LC7		—	—		
45° 3-position Spring Return Two-way		Gold	DPDT	LW6S-33LC2	LW6S-33LC2V	LW6S-33LC2M	
			3PDT	LW6S-33LC3	LW6S-33LC3V	—	
		Silver	DPDT	LW6S-33LC6	—	LW6S-33LC6M	
3PDT	LW6S-33LC7		—	—			

• For contact operation and dimensions, see page 17.

# Flush Silhouette LW Series Selector Switches

## Selector Switches with Square Black Plastic Bezel

Shape	Operation Type	Position	Contact Material	Contact	Type No.					
					Solder/Tab Terminal	PC Board Terminal	Screw Terminal			
Square Black Plastic Bezel LW7S (Knob Operator)    RU SF Δ CE	90° 2-position Maintained		Gold	SPDT	LW7S-2C1	LW7S-2C1V	—			
				DPDT	LW7S-2C2	LW7S-2C2V	LW7S-2C2M			
				3PDT	LW7S-2C3	LW7S-2C3V	—			
			Silver	SPDT	LW7S-2C5	—	—			
				DPDT	LW7S-2C6	—	LW7S-2C6M			
				3PDT	LW7S-2C7	—	—			
	90° 2-position Spring Return from Right		Gold	SPDT	LW7S-21C1	LW7S-21C1V	—			
				DPDT	LW7S-21C2	LW7S-21C2V	LW7S-21C2M			
				3PDT	LW7S-21C3	LW7S-21C3V	—			
			Silver	SPDT	LW7S-21C5	—	—			
				DPDT	LW7S-21C6	—	LW7S-21C6M			
				3PDT	LW7S-21C7	—	—			
	45° 3-position Maintained		Gold	DPDT	LW7S-3C2	LW7S-3C2V	LW7S-3C2M			
				3PDT	LW7S-3C3	LW7S-3C3V	—			
				DPDT	LW7S-3C6	—	LW7S-3C6M			
			Silver	3PDT	LW7S-3C7	—	—			
				45° 3-position Spring Return from Right		Gold	DPDT	LW7S-31C2	LW7S-31C2V	LW7S-31C2M
							3PDT	LW7S-31C3	LW7S-31C3V	—
	DPDT	LW7S-31C6	—				LW7S-31C6M			
	Silver	3PDT	LW7S-31C7			—	—			
		45° 3-position Spring Return from Left				Gold	DPDT	LW7S-32C2	LW7S-32C2V	LW7S-32C2M
							3PDT	LW7S-32C3	LW7S-32C3V	—
	DPDT			LW7S-32C6	—		LW7S-32C6M			
	Silver			3PDT	LW7S-32C7	—	—			
45° 3-position Spring Return Two-way					Gold	DPDT	LW7S-33C2	LW7S-33C2V	LW7S-33C2M	
						3PDT	LW7S-33C3	LW7S-33C3V	—	
	DPDT	LW7S-33C6	—			LW7S-33C6M				
	Silver	3PDT	LW7S-33C7		—	—				
		Square Black Plastic Bezel LW7S (Lever Operator)    RU SF Δ CE	90° 2-position Maintained			Gold	SPDT	LW7S-2LC1	LW7S-2LC1V	—
							DPDT	LW7S-2LC2	LW7S-2LC2V	LW7S-2LC2M
3PDT	LW7S-2LC3			LW7S-2LC3V			—			
Silver	SPDT			LW7S-2LC5		—	—			
	DPDT			LW7S-2LC6		—	LW7S-2LC6M			
	3PDT			LW7S-2LC7		—	—			
90° 2-position Spring Return from Right			Gold	SPDT	LW7S-21LC1	LW7S-21LC1V	—			
				DPDT	LW7S-21LC2	LW7S-21LC2V	LW7S-21LC2M			
				3PDT	LW7S-21LC3	LW7S-21LC3V	—			
			Silver	SPDT	LW7S-21LC5	—	—			
				DPDT	LW7S-21LC6	—	LW7S-21LC6M			
				3PDT	LW7S-21LC7	—	—			
45° 3-position Maintained		Gold	DPDT	LW7S-3LC2	LW7S-3LC2V	LW7S-3LC2M				
			3PDT	LW7S-3LC3	LW7S-3LC3V	—				
			DPDT	LW7S-3LC6	—	LW7S-3LC6M				
		Silver	3PDT	LW7S-3LC7	—	—				
			45° 3-position Spring Return from Right		Gold	DPDT	LW7S-31LC2	LW7S-31LC2V	LW7S-31LC2M	
						3PDT	LW7S-31LC3	LW7S-31LC3V	—	
DPDT	LW7S-31LC6	—				LW7S-31LC6M				
Silver	3PDT	LW7S-31LC7			—	—				
	45° 3-position Spring Return from Left				Gold	DPDT	LW7S-32LC2	LW7S-32LC2V	LW7S-32LC2M	
						3PDT	LW7S-32LC3	LW7S-32LC3V	—	
DPDT			LW7S-32LC6	—		LW7S-32LC6M				
Silver			3PDT	LW7S-32LC7	—	—				
			45° 3-position Spring Return Two-way		Gold	DPDT	LW7S-33LC2	LW7S-33LC2V	LW7S-33LC2M	
						3PDT	LW7S-33LC3	LW7S-33LC3V	—	
DPDT	LW7S-33LC6	—				LW7S-33LC6M				
Silver	3PDT	LW7S-33LC7			—	—				

• For contact operation and dimensions, see page 17.



# Flush Silhouette LW Series Selector Switches

## Contact Operation

Operation Type	Contact	Operator Position and Contact Position (Top View)		Operation Type	Contact	Operator Position and Contact Position (Top View)		
		Left	Right			Left	Center	Right
90° 2-Position	SPDT DPDT	Left Contact NO NC Right Contact NO NC	Left Contact NO NC Right Contact NO NC	45° 3-Position	DPDT	Left Contact NO NC Right Contact NO NC	Left Contact NO NC Right Contact NO NC	Left Contact NO NC Right Contact NO NC
	3PDT	Left Contact NO NC Center Contact NO NC Right Contact NO NC	Left Contact NO NC Center Contact NO NC Right Contact NO NC			Left Contact NO NC Center Contact NO NC Right Contact NO NC	Left Contact NO NC Center Contact NO NC Right Contact NO NC	Left Contact NO NC Center Contact NO NC Right Contact NO NC

• SPDT has C, NO, and NC only in the center of the terminal.

## Dimensions

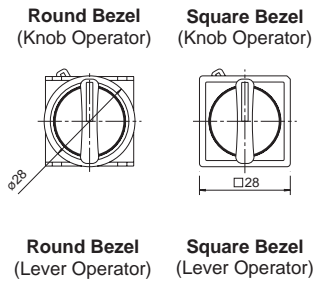
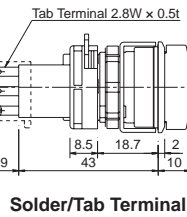
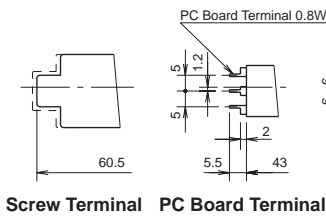
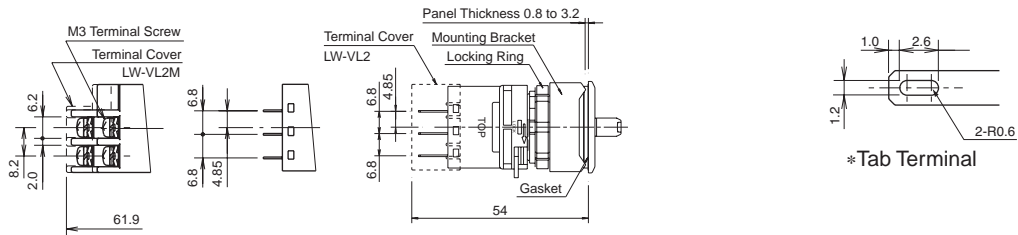

## Bottom View

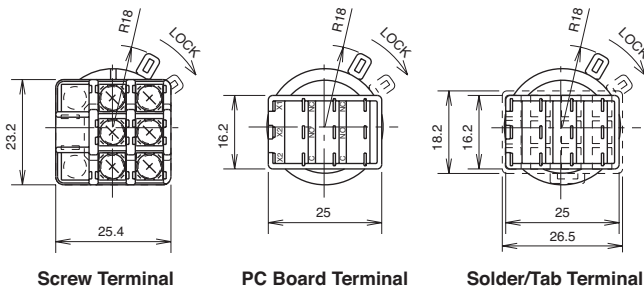

## Terminal Arrangement (Bottom View)

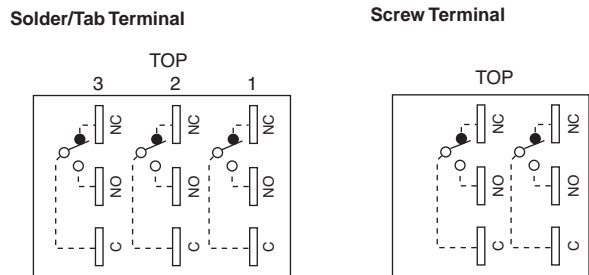

## PC Board Drilling Layout (Bottom View)

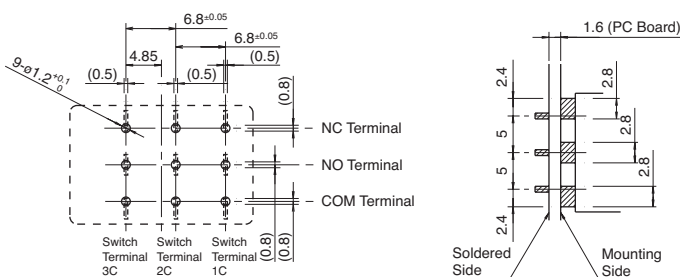













Note:  
SPDT has C, NO, and NC only in the center. DPDT has C, NO, and NC only on the right and left. Screw terminal type is only available in DPDT configuration.



Note the pattern of the PC board as the terminals on the mounting surface are 2.8 mm wide.

# Flush Silhouette LW Series Key Selector Switches

## Key Selector Switches with Round Metal Bezel (2-Position and 3-Position)

Shape	Operation Type	Key retained at ●	Contact Material	Contact	Type No.					
					Solder/Tab Terminal	PC Board Terminal	Screw Terminal			
Round Metal Bezel LW6MK    	90° 2-position Maintained	A		Gold	SPDT	LW6MK-2C1A	LW6MK-2C1VA	—		
					DPDT	LW6MK-2C2A	LW6MK-2C2VA	LW6MK-2C2MA		
					3PDT	LW6MK-2C3A	LW6MK-2C3VA	—		
			Silver	SPDT	LW6MK-2C5A	—	—			
				DPDT	LW6MK-2C6A	—	LW6MK-2C6MA			
				3PDT	LW6MK-2C7A	—	—			
		B		Gold	SPDT	LW6MK-2C1B	LW6MK-2C1VB	—		
					DPDT	LW6MK-2C2B	LW6MK-2C2VB	LW6MK-2C2MB		
					3PDT	LW6MK-2C3B	LW6MK-2C3VB	—		
			Silver	SPDT	LW6MK-2C5B	—	—			
				DPDT	LW6MK-2C6B	—	LW6MK-2C6MB			
				3PDT	LW6MK-2C7B	—	—			
		C		Gold	SPDT	LW6MK-2C1C	LW6MK-2C1VC	—		
					DPDT	LW6MK-2C2C	LW6MK-2C2VC	LW6MK-2C2MC		
					3PDT	LW6MK-2C3C	LW6MK-2C3VC	—		
			Silver	SPDT	LW6MK-2C5C	—	—			
				DPDT	LW6MK-2C6C	—	LW6MK-2C6MC			
				3PDT	LW6MK-2C7C	—	—			
	90° 2-position Spring Return from Right	B		Gold	SPDT	LW6MK-21C1B	LW6MK-21C1VB	—		
					DPDT	LW6MK-21C2B	LW6MK-21C2VB	LW6MK-21C2MB		
					3PDT	LW6MK-21C3B	LW6MK-21C3VB	—		
				Silver	SPDT	LW6MK-21C5B	—	—		
					DPDT	LW6MK-21C6B	—	LW6MK-21C6MB		
					3PDT	LW6MK-21C7B	—	—		
	45° 3-position Maintained	A		Gold	DPDT	LW6MK-3C2A	LW6MK-3C2VA	LW6MK-3C2MA		
					3PDT	LW6MK-3C3A	LW6MK-3C3VA	—		
				Silver	DPDT	LW6MK-3C6A	—	LW6MK-3C6MA		
					3PDT	LW6MK-3C7A	—	—		
				B		Gold	DPDT	LW6MK-3C2B	LW6MK-3C2VB	LW6MK-3C2MB
							3PDT	LW6MK-3C3B	LW6MK-3C3VB	—
		Silver	DPDT			LW6MK-3C6B	—	LW6MK-3C6MB		
			3PDT		LW6MK-3C7B	—	—			
		C			Gold	DPDT	LW6MK-3C2C	LW6MK-3C2VC	LW6MK-3C2MC	
						3PDT	LW6MK-3C3C	LW6MK-3C3VC	—	
				Silver	DPDT	LW6MK-3C6C	—	LW6MK-3C6MC		
				3PDT	LW6MK-3C7C	—	—			
			D		Gold	DPDT	LW6MK-3C2D	LW6MK-3C2VD	LW6MK-3C2MD	
						3PDT	LW6MK-3C3D	LW6MK-3C3VD	—	
		Silver			DPDT	LW6MK-3C6D	—	LW6MK-3C6MD		
				3PDT	LW6MK-3C7D	—	—			
		E			Gold	DPDT	LW6MK-3C2E	LW6MK-3C2VE	LW6MK-3C2ME	
						3PDT	LW6MK-3C3E	LW6MK-3C3VE	—	
			Silver		DPDT	LW6MK-3C6E	—	LW6MK-3C6ME		
				3PDT	LW6MK-3C7E	—	—			
			G		Gold	DPDT	LW6MK-3C2G	LW6MK-3C2VG	LW6MK-3C2MG	
						3PDT	LW6MK-3C3G	LW6MK-3C3VG	—	
		Silver			DPDT	LW6MK-3C6G	—	LW6MK-3C6MG		
				3PDT	LW6MK-3C7G	—	—			
H				Gold	DPDT	LW6MK-3C2H	LW6MK-3C2VH	LW6MK-3C2MH		
					3PDT	LW6MK-3C3H	LW6MK-3C3VH	—		
			Silver	DPDT	LW6MK-3C6H	—	LW6MK-3C6MH			
			3PDT	LW6MK-3C7H	—	—				

# Flush Silhouette LW Series Key Selector Switches

Shape	Operation Type	Key retained at ●	Contact Material	Contact	Type No.		
					Solder/Tab Terminal	PC Board Terminal	Screw Terminal
Round Metal Bezel LW6MK    	45° 3-position Spring Return from Right	B	Gold	DPDT	LW6MK-31C2B	LW6MK-31C2VB	LW6MK-31C2MB
				3PDT	LW6MK-31C3B	LW6MK-31C3VB	—
			Silver	DPDT	LW6MK-31C6B	—	LW6MK-31C6MB
				3PDT	LW6MK-31C7B	—	—
		D	Gold	DPDT	LW6MK-31C2D	LW6MK-31C2VD	LW6MK-31C2MD
				3PDT	LW6MK-31C3D	LW6MK-31C3VD	—
			Silver	DPDT	LW6MK-31C6D	—	LW6MK-31C6MD
				3PDT	LW6MK-31C7D	—	—
		G	Gold	DPDT	LW6MK-31C2G	LW6MK-31C2VG	LW6MK-31C2MG
				3PDT	LW6MK-31C3G	LW6MK-31C3VG	—
			Silver	DPDT	LW6MK-31C6G	—	LW6MK-31C6MG
				3PDT	LW6MK-31C7G	—	—
	45° 3-position Spring Return from Left	C	Gold	DPDT	LW6MK-32C2C	LW6MK-32C2VC	LW6MK-32C2MC
				3PDT	LW6MK-32C3C	LW6MK-32C3VC	—
			Silver	DPDT	LW6MK-32C6C	—	LW6MK-32C6MC
				3PDT	LW6MK-32C7C	—	—
		D	Gold	DPDT	LW6MK-32C2D	LW6MK-32C2VD	LW6MK-32C2MD
				3PDT	LW6MK-32C3D	LW6MK-32C3VD	—
			Silver	DPDT	LW6MK-32C6D	—	LW6MK-32C6MD
				3PDT	LW6MK-32C7D	—	—
		H	Gold	DPDT	LW6MK-32C2H	LW6MK-32C2VH	LW6MK-32C2MH
				3PDT	LW6MK-32C3H	LW6MK-32C3VH	—
			Silver	DPDT	LW6MK-32C6H	—	LW6MK-32C6MH
				3PDT	LW6MK-32C7H	—	—
45° 3-position Spring Return Two-way	D	Gold	DPDT	LW6MK-33C2D	LW6MK-33C2VD	LW6MK-33C2MD	
			3PDT	LW6MK-33C3D	LW6MK-33C3VD	—	
		Silver	DPDT	LW6MK-33C6D	—	LW6MK-33C6MD	
			3PDT	LW6MK-33C7D	—	—	



- Key is retained in ● position and removable in ○ position.
- Two keys are supplied.
- Key cylinder face material: Metal
- To select key numbers, specify numbers 501 to 515 after the Type No. When a key number is not specified, key number 500 is supplied as the default key.

Example: LW6MK-2C1A-501

500 (default key) to 515

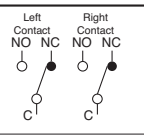
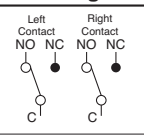

\* Other than the above 16 numbers, 44 additional key numbers are available upon request.

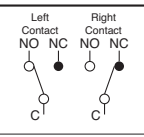
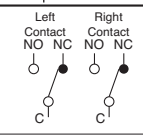
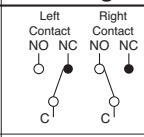
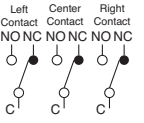
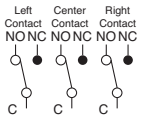
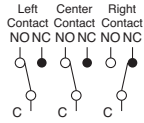
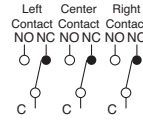
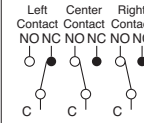
## Contact Operation



Operation Type	Contact	Operator Position and Contact Position (Top View)		Operation Type	Contact	Operator Position and Contact Position (Top View)		
		Left	Right			Left	Center	Right
90° 2-Position  	SPDT DPDT			45° 3-Position  	DPDT			
	3PDT				3PDT			

# Flush Silhouette LW Series Key Selector Switches

## Key Selector Switches with Black Plastic Bezel (2-Position and 3-Position)

Shape	Operation Type	Key retained at ●	Contact Material	Contact	Type No.			
					Solder/Tab Terminal	PC Board Terminal	Screw Terminal	
Round Black Plastic Bezel LW6K    	90° 2-position Maintained	A	Gold	SPDT	LW6K-2C1A	LW6K-2C1VA	—	
				DPDT	LW6K-2C2A	LW6K-2C2VA	LW6K-2C2MA	
				3PDT	LW6K-2C3A	LW6K-2C3VA	—	
			Silver	SPDT	LW6K-2C5A	—	—	
				DPDT	LW6K-2C6A	—	LW6K-2C6MA	
				3PDT	LW6K-2C7A	—	—	
		B	Gold	SPDT	LW6K-2C1B	LW6K-2C1VB	—	
				DPDT	LW6K-2C2B	LW6K-2C2VB	LW6K-2C2MB	
				3PDT	LW6K-2C3B	LW6K-2C3VB	—	
			Silver	SPDT	LW6K-2C5B	—	—	
				DPDT	LW6K-2C6B	—	LW6K-2C6MB	
				3PDT	LW6K-2C7B	—	—	
		C	Gold	SPDT	LW6K-2C1C	LW6K-2C1VC	—	
				DPDT	LW6K-2C2C	LW6K-2C2VC	LW6K-2C2MC	
				3PDT	LW6K-2C3C	LW6K-2C3VC	—	
			Silver	SPDT	LW6K-2C5C	—	—	
				DPDT	LW6K-2C6C	—	LW6K-2C6MC	
				3PDT	LW6K-2C7C	—	—	
	90° 2-position Spring Return from Right	B	Gold	SPDT	LW6K-21C1B	LW6K-21C1VB	—	
				DPDT	LW6K-21C2B	LW6K-21C2VB	LW6K-21C2MB	
				3PDT	LW6K-21C3B	LW6K-21C3VB	—	
			Silver	SPDT	LW6K-21C5B	—	—	
				DPDT	LW6K-21C6B	—	LW6K-21C6MB	
				3PDT	LW6K-21C7B	—	—	
	45° 3-position Maintained	A	Gold	DPDT	LW6K-3C2A	LW6K-3C2VA	LW6K-3C2MA	
				3PDT	LW6K-3C3A	LW6K-3C3VA	—	
				Silver	DPDT	LW6K-3C6A	—	LW6K-3C6MA
			Silver	3PDT	LW6K-3C7A	—	—	
				Gold	DPDT	LW6K-3C2B	LW6K-3C2VB	LW6K-3C2MB
					3PDT	LW6K-3C3B	LW6K-3C3VB	—
		Silver	DPDT		LW6K-3C6B	—	LW6K-3C6MB	
		Silver	3PDT	LW6K-3C7B	—	—		
			Gold	DPDT	LW6K-3C2C	LW6K-3C2VC	LW6K-3C2MC	
				3PDT	LW6K-3C3C	LW6K-3C3VC	—	
		Silver		DPDT	LW6K-3C6C	—	LW6K-3C6MC	
		Silver	3PDT	LW6K-3C7C	—	—		
			Gold	DPDT	LW6K-3C2D	LW6K-3C2VD	LW6K-3C2MD	
				3PDT	LW6K-3C3D	LW6K-3C3VD	—	
		Silver		DPDT	LW6K-3C6D	—	LW6K-3C6MD	
		Silver	3PDT	LW6K-3C7D	—	—		
			Gold	DPDT	LW6K-3C2E	LW6K-3C2VE	LW6K-3C2ME	
				3PDT	LW6K-3C3E	LW6K-3C3VE	—	
		Silver		DPDT	LW6K-3C6E	—	LW6K-3C6ME	
		Silver	3PDT	LW6K-3C7E	—	—		
			Gold	DPDT	LW6K-3C2G	LW6K-3C2VG	LW6K-3C2MG	
				3PDT	LW6K-3C3G	LW6K-3C3VG	—	
		Silver		DPDT	LW6K-3C6G	—	LW6K-3C6MG	
		Silver	3PDT	LW6K-3C7G	—	—		
Gold			DPDT	LW6K-3C2H	LW6K-3C2VH	LW6K-3C2MH		
			3PDT	LW6K-3C3H	LW6K-3C3VH	—		
		Silver	DPDT	LW6K-3C6H	—	LW6K-3C6MH		
Silver		3PDT	LW6K-3C7H	—	—			

# Flush Silhouette LW Series Key Selector Switches

Shape	Operation Type	Key retained at ●	Contact Material	Contact	Type No.		
					Solder/Tab Terminal	PC Board Terminal	Screw Terminal
Round Black Plastic Bezel LW6K    	45° 3-position Spring Return from Right	B	Gold	DPDT	LW6K-31C2B	LW6K-31C2VB	LW6K-31C2MB
				3PDT	LW6K-31C3B	LW6K-31C3VB	—
			Silver	DPDT	LW6K-31C6B	—	LW6K-31C6MB
				3PDT	LW6K-31C7B	—	—
		D	Gold	DPDT	LW6K-31C2D	LW6K-31C2VD	LW6K-31C2MD
				3PDT	LW6K-31C3D	LW6K-31C3VD	—
			Silver	DPDT	LW6K-31C6D	—	LW6K-31C6MD
				3PDT	LW6K-31C7D	—	—
		G	Gold	DPDT	LW6K-31C2G	LW6K-31C2VG	LW6K-31C2MG
				3PDT	LW6K-31C3G	LW6K-31C3VG	—
			Silver	DPDT	LW6K-31C6G	—	LW6K-31C6MG
				3PDT	LW6K-31C7G	—	—
	45° 3-position Spring Return from Left	C	Gold	DPDT	LW6K-32C2C	LW6K-32C2VC	LW6K-32C2MC
				3PDT	LW6K-32C3C	LW6K-32C3VC	—
			Silver	DPDT	LW6K-32C6C	—	LW6K-32C6MC
				3PDT	LW6K-32C7C	—	—
		D	Gold	DPDT	LW6K-32C2D	LW6K-32C2VD	LW6K-32C2MD
				3PDT	LW6K-32C3D	LW6K-32C3VD	—
			Silver	DPDT	LW6K-32C6D	—	LW6K-32C6MD
				3PDT	LW6K-32C7D	—	—
		H	Gold	DPDT	LW6K-32C2H	LW6K-32C2VH	LW6K-32C2MH
				3PDT	LW6K-32C3H	LW6K-32C3VH	—
			Silver	DPDT	LW6K-32C6H	—	LW6K-32C6MH
				3PDT	LW6K-32C7H	—	—
45° 3-position Spring Return Two-way	D	Gold	DPDT	LW6K-33C2D	LW6K-33C2VD	LW6K-33C2MD	
			3PDT	LW6K-33C3D	LW6K-33C3VD	—	
		Silver	DPDT	LW6K-33C6D	—	LW6K-33C6MD	
			3PDT	LW6K-33C7D	—	—	



- Key is retained in ● position and removable in ○ position.
- Two keys are supplied.
- Key cylinder face material: Metal
- To select key numbers, specify numbers 501 to 515 after the Type No. When a key number is not specified, key number 500 is supplied as the default key.

Example: LW6K-2C1A-501

500 (default key) to 515

\* Other than the above 16 numbers, 44 additional key numbers are available upon request.

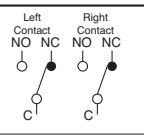
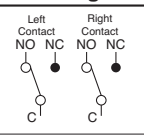
## Contact Operation

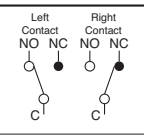
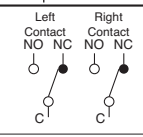
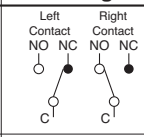
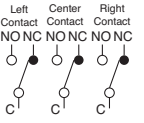
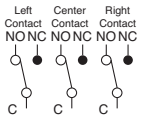
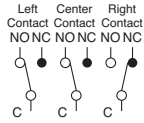
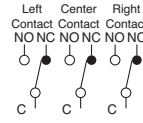
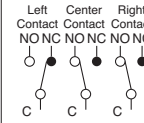
Operation Type	Contact	Operator Position and Contact Position (Top View)		Operation Type	Contact	Operator Position and Contact Position (Top View)		
		Left	Right			Left	Center	Right
90° 2-Position  	SPDT DPDT			45° 3-Position  	DPDT			
	3PDT				3PDT			

# Flush Silhouette LW Series Key Selector Switches

## Dimensions

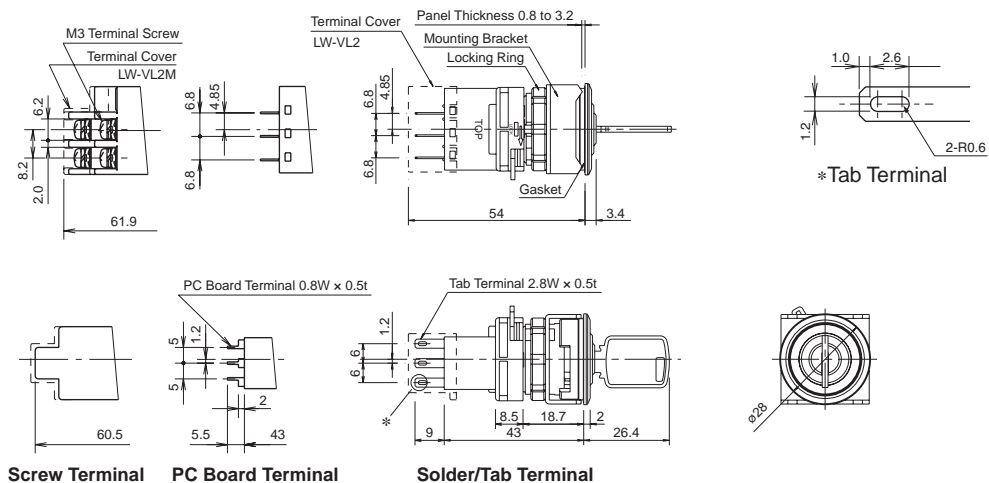

## Bottom View

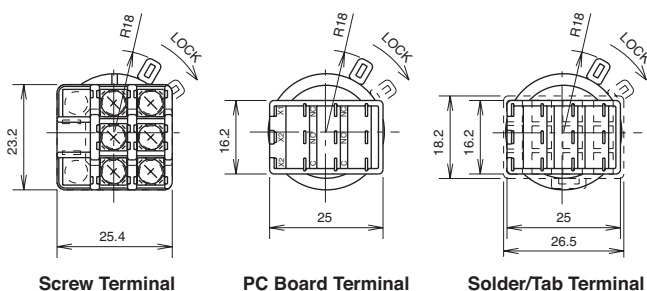

## Terminal Arrangement (Bottom View)

### • Solder/Tab Terminal

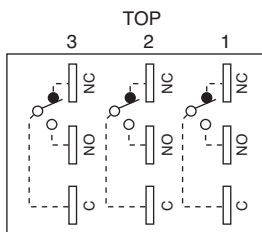

Note:  
 SPDT has C, NO, and NC only in the center. DPDT has C, NO, and NC only on the right and left.  
 Screw terminal type is only available in DPDT configuration.

### • Screw Terminal

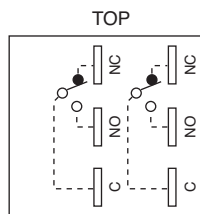

## PC Board Drilling Layout (Bottom View)

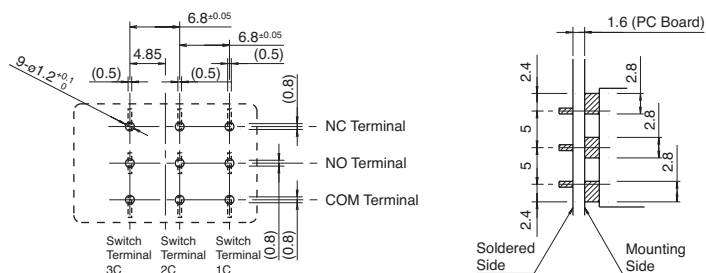





Note the pattern of the PC board as the terminals on the mounting surface are 2.8 mm wide.

All dimensions in mm.







# Flush Silhouette LW Series Illuminated Selector Switches

## Illuminated Selector Switches with Round Metal / Black Plastic Bezel

Shape	Operation Type	Position	Contact Material	Contact	Type No.			
					Solder/Tab Terminal	PC Board Terminal	Screw Terminal	
Round Metal Bezel LW6MF (Knob Operator)    UL SP A CE	90° 2-position Maintained		Gold	SPDT	LW6MF-2C1③②	LW6MF-2C1③V②	—	
				DPDT	LW6MF-2C2③②	LW6MF-2C2③V②	LW6MF-2C2③M②	
				3PDT	LW6MF-2C3③②	LW6MF-2C3③V②	—	
			Silver	SPDT	LW6MF-2C5③②	—	—	
				DPDT	LW6MF-2C6③②	—	LW6MF-2C6③M②	
				3PDT	LW6MF-2C7③②	—	—	
	90° 2-position Spring Return from Right		Gold	SPDT	LW6MF-21C1③②	LW6MF-21C1③V②	—	
				DPDT	LW6MF-21C2③②	LW6MF-21C2③V②	LW6MF-21C2③M②	
				3PDT	LW6MF-21C3③②	LW6MF-21C3③V②	—	
			Silver	SPDT	LW6MF-21C5③②	—	—	
				DPDT	LW6MF-21C6③②	—	LW6MF-21C6③M②	
				3PDT	LW6MF-21C7③②	—	—	
	45° 3-position Maintained		Gold	DPDT	LW6MF-3C2③②	LW6MF-3C2③V②	LW6MF-3C2③M②	
				3PDT	LW6MF-3C3③②	LW6MF-3C3③V②	—	
				Silver	DPDT	LW6MF-3C6③②	—	LW6MF-3C6③M②
			Silver	3PDT	LW6MF-3C7③②	—	—	
				Gold	DPDT	LW6MF-31C2③②	LW6MF-31C2③V②	LW6MF-31C2③M②
					3PDT	LW6MF-31C3③②	LW6MF-31C3③V②	—
	Silver	DPDT	LW6MF-31C6③②		—	LW6MF-31C6③M②		
	Silver	3PDT	LW6MF-31C7③②	—	—			
		Gold	DPDT	LW6MF-32C2③②	LW6MF-32C2③V②	LW6MF-32C2③M②		
			3PDT	LW6MF-32C3③②	LW6MF-32C3③V②	—		
	Silver		DPDT	LW6MF-32C6③②	—	LW6MF-32C6③M②		
	Silver	3PDT	LW6MF-32C7③②	—	—			
Gold		DPDT	LW6MF-33C2③②	LW6MF-33C2③V②	LW6MF-33C2③M②			
		3PDT	LW6MF-33C3③②	LW6MF-33C3③V②	—			
	Silver	DPDT	LW6MF-33C6③②	—	LW6MF-33C6③M②			
Silver	3PDT	LW6MF-33C7③②	—	—				

# Flush Silhouette LW Series Illuminated Selector Switches

## Illuminated Selector Switches with Square Black Plastic Bezel

Shape	Operation Type	Position	Contact Material	Contact	Type No.					
					Solder/Tab Terminal	PC Board Terminal	Screw Terminal			
 Square Black Plastic Bezel LW7F (Knob Operator)	90° 2-position Maintained		Gold	SPDT	LW7F-2C1③②	LW7F-2C1③V②	—			
				DPDT	LW7F-2C2③②	LW7F-2C2③V②	LW7F-2C2③M②			
				3PDT	LW7F-2C3③②	LW7F-2C3③V②	—			
			Silver	SPDT	LW7F-2C5③②	—	—			
				DPDT	LW7F-2C6③②	—	LW7F-2C6③M②			
				3PDT	LW7F-2C7③②	—	—			
	90° 2-position Spring Return from Right		Gold	SPDT	LW7F-21C1③②	LW7F-21C1③V②	—			
				DPDT	LW7F-21C2③②	LW7F-21C2③V②	LW7F-21C2③M②			
				3PDT	LW7F-21C3③②	LW7F-21C3③V②	—			
			Silver	SPDT	LW7F-21C5③②	—	—			
				DPDT	LW7F-21C6③②	—	LW7F-21C6③M②			
				3PDT	LW7F-21C7③②	—	—			
	45° 3-position Maintained		Gold	DPDT	LW7F-3C2③②	LW7F-3C2③V②	LW7F-3C2③M②			
				3PDT	LW7F-3C3③②	LW7F-3C3③V②	—			
				Silver	DPDT	LW7F-3C6③②	—	LW7F-3C6③M②		
			Silver	3PDT	LW7F-3C7③②	—	—			
				45° 3-position Spring Return from Right		Gold	DPDT	LW7F-31C2③②	LW7F-31C2③V②	LW7F-31C2③M②
							3PDT	LW7F-31C3③②	LW7F-31C3③V②	—
	Silver	DPDT	LW7F-31C6③②				—	LW7F-31C6③M②		
	Silver	3PDT	LW7F-31C7③②			—	—			
		45° 3-position Spring Return from Left				Gold	DPDT	LW7F-32C2③②	LW7F-32C2③V②	LW7F-32C2③M②
							3PDT	LW7F-32C3③②	LW7F-32C3③V②	—
	Silver			DPDT	LW7F-32C6③②		—	LW7F-32C6③M②		
	Silver			3PDT	LW7F-32C7③②	—	—			
45° 3-position Spring Return Two-way					Gold	DPDT	LW7F-33C2③②	LW7F-33C2③V②	LW7F-33C2③M②	
						3PDT	LW7F-33C3③②	LW7F-33C3③V②	—	
	Silver	DPDT	LW7F-33C6③②			—	LW7F-33C6③M②			
	Silver	3PDT	LW7F-33C7③②		—	—				





### • Color Code and Operating Voltage Code

② Lens/LED Color Code	③ Operating Voltage Code
Specify a Lens/LED color code in place of ② in the Type No.	Specify an operating voltage code in place of ③ in the Type No.
A: amber G: green R: red S: blue W: white Y: yellow	2: 6V AC/DC 3: 12V AC/DC 4: 24V AC/DC

• Every illuminated selector switch contains an LED lamp (LSTD) of the specified color and voltage.

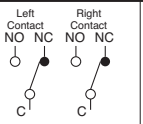
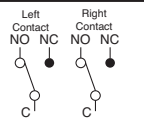
### Contact Operation

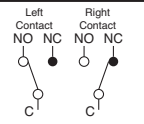
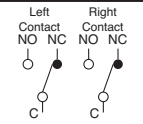
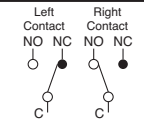
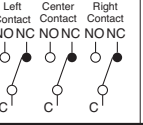
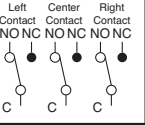
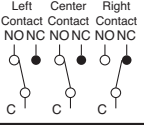
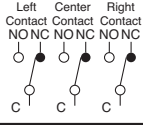
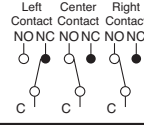
Operation Type	Contact	Operator Position and Contact Position (Top View)		Operation Type	Contact	Operator Position and Contact Position (Top View)		
		Left	Right			Left	Center	Right
 90° 2-Position	SPDT DPDT			 45° 3-Position	DPDT			
	3PDT							



# Flush Silhouette LW Series Illuminated Selector Switches

## Dimensions

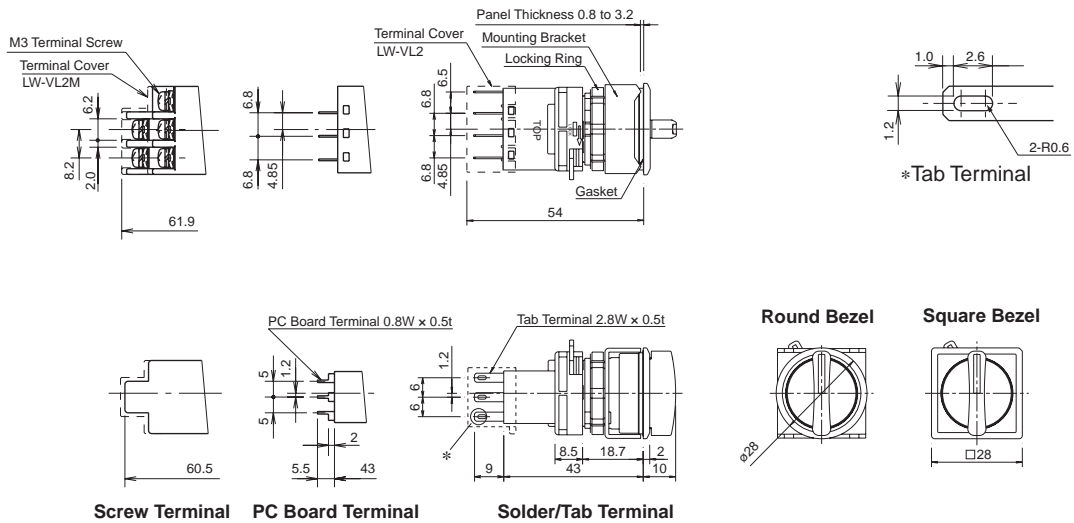

## Bottom View

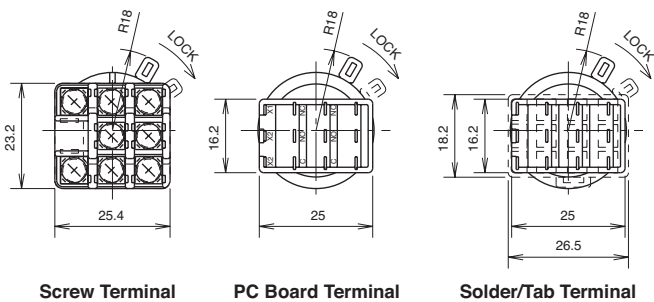

## Terminal Arrangement (Bottom View)

### • Solder/Tab Terminal

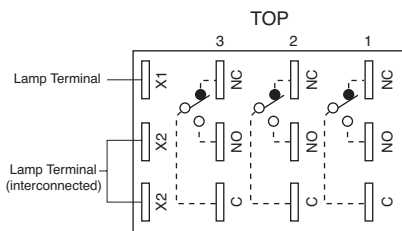

Note: SPDT has C, NO, and NC only in the center. DPDT has C, NO, and NC only on the right and left. Lamp terminals do not have any polarity.

### • Screw Terminal

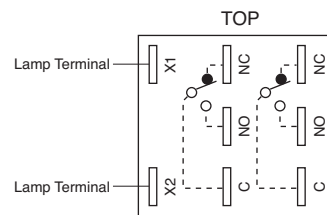



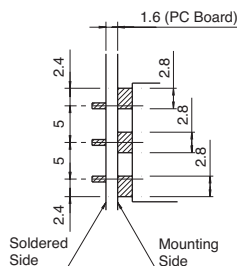
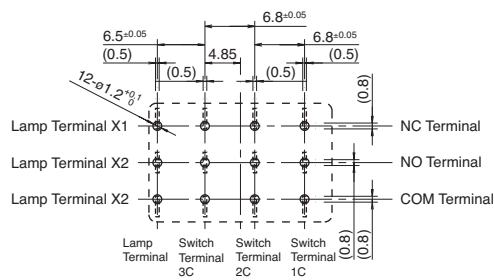







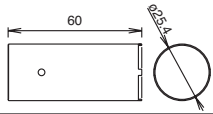

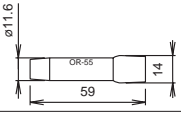

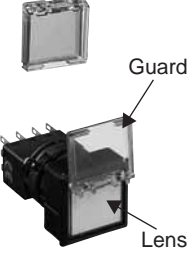
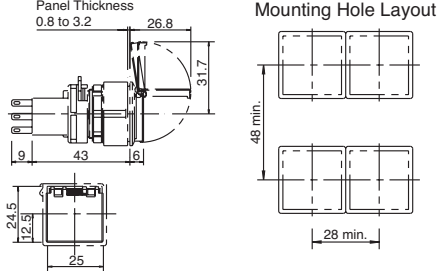

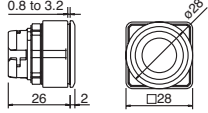
## PC Board Drilling Layout (Bottom View)

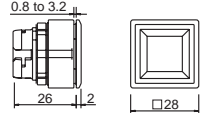

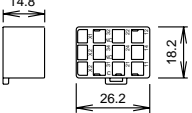

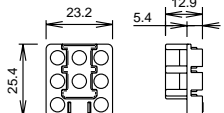

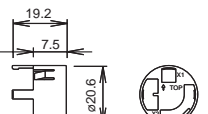

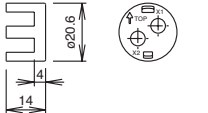



Note the pattern of the PC board as the terminals on the mounting surface are 2.8 mm wide.

All dimensions in mm.

# Flush Silhouette LW Series Accessories

Accessories				
Shape	Material	Type No. (Ordering Type No.)	Package Quantity	Dimensions (mm)
	Metal (nickel-plated brass)	LW9Z-T1	1	<ul style="list-style-type: none"> <li>Used to tighten the locking ring when installing the control unit into a panel.</li> <li>Tightening torque: 1.2 N·m</li> </ul> 
	Rubber	OR-55	1	<ul style="list-style-type: none"> <li>Used to install and remove LED lamps.</li> </ul> 
	Rubber (Ring: metal)	MT-S01	1	<ul style="list-style-type: none"> <li>Used to remove the lens.</li> </ul>
Switch Guard with Lens (for Square Flush Lens) Spring Return Type 	Plastic (Guard: transparent)	LW9Z-KS7②	1	<ul style="list-style-type: none"> <li>Switch guard accessory comes with lens.</li> <li>Cannot be used with maintained types (momentary buttons only).</li> <li>Specify a lens color code in place of ② in the Type No. A: amber, C: clear, G: green, R: red, S: blue, Y: yellow</li> <li>Use a clear lens for white illumination or for white (LW) or black (LB) buttons.</li> </ul>  <p>Note: Determine mounting centers to ensure easy operation.</p>
	Plastic (black)	LW9Z-BS6	1	<ul style="list-style-type: none"> <li>Degree of protection: IP65</li> <li>Panel thickness: 0.8 to 3.2 mm</li> <li>See page 5 for mounting hole layout.</li> </ul> 
	Plastic (black)	LW9Z-BS7	1	<ul style="list-style-type: none"> <li>Degree of protection: IP65</li> <li>Panel thickness: 0.8 to 3.2 mm</li> <li>See page 5 for mounting hole layout.</li> </ul> 
	Plastic (translucent)	LW-VL2	1	<ul style="list-style-type: none"> <li>For separate type control units only.</li> </ul> 
	Plastic (black)	LW-VL2M	1	<ul style="list-style-type: none"> <li>For separate type control units only.</li> </ul> 
	Plastic (translucent)	LW-PVL	1	<ul style="list-style-type: none"> <li>For unibody type pilot lights only.</li> </ul> 
	Plastic (translucent)	LW-PVLM	1	<ul style="list-style-type: none"> <li>For unibody type pilot lights only.</li> </ul> 

# Flush Silhouette LW Series Accessories



Replacement Parts						
Shape	Material	Type No.	Ordering Type No.	Package Quantity	Color Code	
Lens (Round Flush) 	Polyarylate	LW9Z-L1②	LW9Z-L1②PN05	5	Specify a lens color code in place of ② in the Ordering Type No.  A: amber C: clear G: green R: red S: blue Y: yellow	
Lens (Round Extended) 	Polyarylate	LW9Z-L12②	LW9Z-L12②PN05	5		
Lens (Square Flush) 	Polyarylate	LW9Z-L2②	LW9Z-L2②PN05	5		
Lens for Pilot Lights (Round Extended) 	Polyarylate	LW9Z-L15②	LW9Z-L15②PN05	5		
Lens for Pilot Lights (Square Extended) 	Polyarylate	LW9Z-L25②	LW9Z-L25②PN05	5		
Illuminated Selector Knob Operator 	Plastic	LW9Z-FD6②	LW9Z-FD6②	1	Specify a lens color code in place of ② in the Ordering Type No.  • A: amber, G: green, R: red, S: blue, W: white, Y: yellow	
Marking Plate (Round) 	Acrylic	White	LW9Z-P1W	LW9Z-P1WPN05	5	• For round flush pushbuttons, round flush illuminated pushbuttons, and round extended pilot lights.
		Black	LW9Z-P1B	LW9Z-P1BPN05		
Marking Plate (Square) 	Acrylic	White	LW9Z-P2W	LW9Z-P2WPN05	5	• For square flush pushbuttons, square flush illuminated pushbuttons, and square extended pilot lights.
		Black	LW9Z-P2B	LW9Z-P2BPN05		
Marking Plate (Round Extended) 	Acrylic	White	LW9Z-P12W	LW9Z-P12WPN05	5	• For round extended pushbuttons and round extended illuminated pushbuttons.
		Black	LW9Z-P12B	LW9Z-P12BPN05		
Locking Ring 	Plastic	LW9Z-LN	LW9Z-LNPN05	5	• Black	
Spare Key 	Metal	LW9Z-SK-500	LW9Z-SK-500PN2	2	• Standard – default key	
		LW9Z-SK-④	LW9Z-SK-④PN02		• Specify a key number 501 to 515 in place of ④ in the Type No.	

# Flush Silhouette LW Series Accessories

## LED Lamps

Operating Voltage	Current Draw		Type No.	Ordering Type No.	Illumination Color Code	Package Quantity	Base
	AC	DC					
6V AC/DC±10%	17 mA (A, R, W, Y) 8 mA (G, S)	14 mA (A, R, W, Y) 5.5 mA (G, S)	LSTD-6②	LSTD-6②	Specify a color code in place of ② in the Ordering Type No.  A: amber G: green R: red S: blue W: white Y: yellow	1	BA9S/13
				LSTD-6②PN10		10	
12V AC/DC±10%	11 mA	10 mA	LSTD-1②	LSTD-1②		1	
				LSTD-1②PN10		10	
24V AC/DC±10%	11 mA	10 mA	LSTD-2②	LSTD-2②		1	
				LSTD-2②PN10		10	

## Transformers

Separate Mounting Type	Primary Voltage	Secondary Voltage	Type No.	Applicable LED Lamp
For 6V 	100/110V AC	1W/5.5V AC	TWR516	LSTD-6②
	200/220V AC		TWR526	
	400/440V AC		TWR546	
For 24V 	100/110V AC	0.5W/24V AC	TWR512	LSTD-2②
	200/220V AC		TWR522	
	400/440V AC		TWR542	

- Terminal covers are included with separate mounting type transformers.
- Connect only one LSTD LED lamp to each separate mounting type transformer.

## Safety Precautions

- Turn off the power to the flush silhouette LW series control units before installation, removal, wiring, maintenance, and inspection. Failure to turn power off may cause electrical shocks or fire hazard.
- To avoid burning your hand, use the lamp holder tool when replacing lamps.
- For wiring, use wires of a proper size to meet voltage and current requirements. Solder correctly according to the instructions in "Wiring" and "Notes on Terminal Cover." Tighten the M3.5 terminal screws to a torque of 0.6 to 1.0 N-m. Failure to tighten terminal screws may cause overheating and fire.

## Instructions

### Panel Mounting

Remove the contact block from the operator. Insert the operator into the panel cut-out from the front, then install the contact block.

#### • Removing the Contact Block

Turn the locking lever on the contact block in the direction opposite to the arrow on the housing. Then the contact can be removed.

#### • Installing the Contact Block

Insert the contact block, with the TOP markings on the contact block and the operator placed in the same direction. Then lock the units, turning the locking lever in the direction of the arrow.

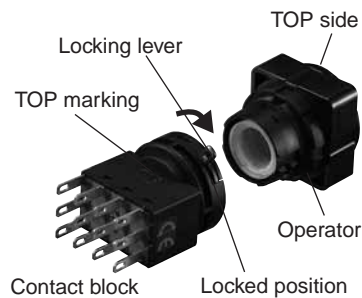

#### • Notes on Mounting

Use the optional locking ring wrench (LW9Z-T1) to mount the operator into the panel. Tightening torque should not exceed 1.2 N-m. Do not use pliers. Excessive tightening will damage the locking ring.

#### • Collective Mounting

As the locking lever can be turned easily from the rear of the units using a screwdriver, the contact blocks can be removed even when mounted collectively.

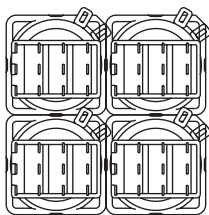

### Replacement of the Lens and Marking Plate

#### • Removal

1. To remove the lens unit, press the suction cup of the optional lens removal tool (MT-S01) onto the lens and pull the lens unit out.

[Removing the Lens Unit]

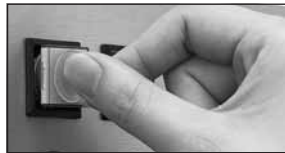

2. Remove the marking plate by pushing the lens from the rear to disengage the latches between the lens and the lens holder, using a screwdriver as shown below.

[Removing the Lens]



Note: The translucent filter in the lens holder cannot be removed because the filter is sealed to make the unit waterproof and oiltight.

#### • Installing

1. For round lenses, place the marking plate on the lens holder with the anti-rotation projection engaged and press the lens into the lens holder to engage the latches. For square lenses, insert the marking plate into the lens, and press the lens into the holder to engage the latches.

2. Make sure of the correct orientation of the marking plate.

#### • Round Lens Type

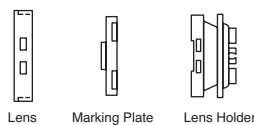

#### • Square Lens Type

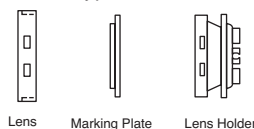

### Marking Plate and Film

For LW series illuminated pushbuttons and pilot lights, legends and symbols can be engraved on marking plates, or printed film can be inserted under the lens for labelling purposes.

#### • Marking Plate and Marking Film Size

Lens	Round Lens	Square Lens
Built-in Marking Plate		
Applicable Marking Film		
	<ul style="list-style-type: none"> <li>• Engraving must be made on the engraving area within 0.5mm deep.</li> <li>• The marking plate is made of acrylic resin.</li> </ul>	<ul style="list-style-type: none"> <li>• Two 0.1mm-thick films or one 0.2mm-thick film can be installed in the lens.</li> <li>• Marking film must be prepared separately.</li> <li>• Recommended marking film: Polyester</li> </ul>

#### • Insertion Order of Marking Plate and Film

##### • Round Lens Type

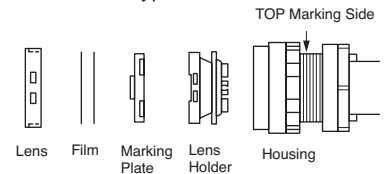

Note: Film must be prepared separately.

##### • Square Lens Type

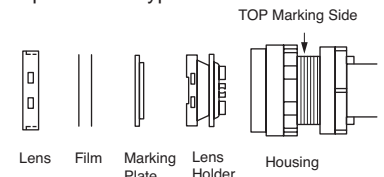

Note: Film must be prepared separately. Make sure of correct orientation of the marking plate.

## Instructions

### Replacement of Lamps

Lamps can be replaced using the lamp holder tool (OR-55) from the front of the panel, or by removing the contact block from the operator.

#### • Removing the Lamp

To remove, slip the lamp holder tool onto the lamp head. Then push slightly, and turn the lamp holder tool counterclockwise.



Lamp Removal Tool  
OR-55



#### • Installing the Lamp

1. To install, insert the lamp head into the lamp holder tool, and hold the lamp as shown in the figure below.

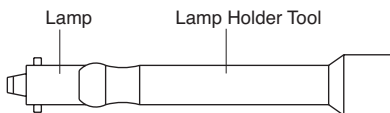

2. Insert the pins on the lamp base into the grooves in the lamp socket. Insert the lamp and turn it clockwise.

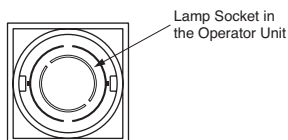

### Removing the Illuminated Selector Switch Knob

#### • Removing the Knob

Insert a flat screwdriver and remove the knob from the operator.

#### • Installing the Knob

Press the knob into the operator. Align the recess on top end of the knob with the lowest rib on of the operator.

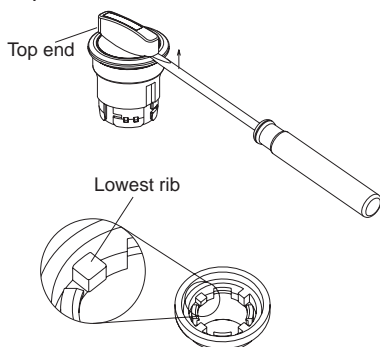

### Key Selector Switches

- When turning the key, do not pull the key out, otherwise, it may cause damage to the switches.

### Wiring

1. Solder the terminals within 20W/5 sec or 260°C/3 sec without exerting external force to the terminals. While soldering, do not touch the soldering iron to the housing. While wiring, prevent tension from being applied to the terminals. Do not bend or raise the terminals, nor exert excessive force to terminals.
2. Use non-corrosive liquid flux.
3. Positive-lock connector and easy-lock connectors are applicable to tab terminals.
4. Tighten the terminal screw of the screw terminal type to a torque of 0.6 to 1.0 N·m.

### Notes on Terminal Cover

[Solder/Tab Terminal]

Insert the terminal cover into the contact block with the TOP markings on the contact block and the terminal cover in the same direction.

Note: When wiring, insert the lead wires into the terminal cover holes before soldering.



#### • Notes on Wiring

When installing a terminal cover onto the solder/tab terminal contact block, solder the inside of lamp terminal (toward the switch terminals) and wire.

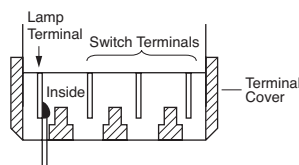

[Screw Terminal]

Install the terminal cover on the control unit before wiring.

Note 1: After wiring, terminal covers cannot be installed.

Note 2: When terminal covers are installed, ring type crimping terminals cannot be used. (For wiring, use fork terminals or lead wires directly.)

### Single Board Mounting

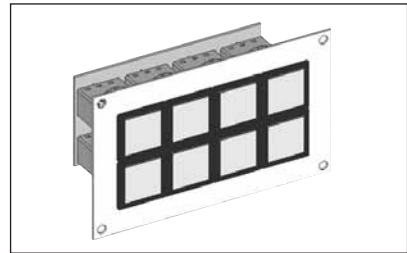

Mounting the control units on a single PC board offers the following features.

1. Reduced installation labor, easy wiring, space saving, and standardization.
2. Since the contact blocks on the PC board can be removed easily using a locking lever, control units are easy to maintain.
3. Because the control units require no studs for fastening the control units to a PC board, special preparation of the panel is not needed.
4. For details on single board mounting, contact IDEC.

# Flush Silhouette L6/A6 series Accessories

## New flush silhouette bezels for L6/A6 series ø16mm miniature control units

- Accessories for L6/A6 control units.
- Bezel Size
  - Round: ø24 mm (Panel Cut-out: ø20.2 mm)
  - Square: □24 mm (Panel Cut-out: □20.2 mm)
  - Rectangular: 24×30 mm (Panel Cut-out: 20.2×26.2 mm)





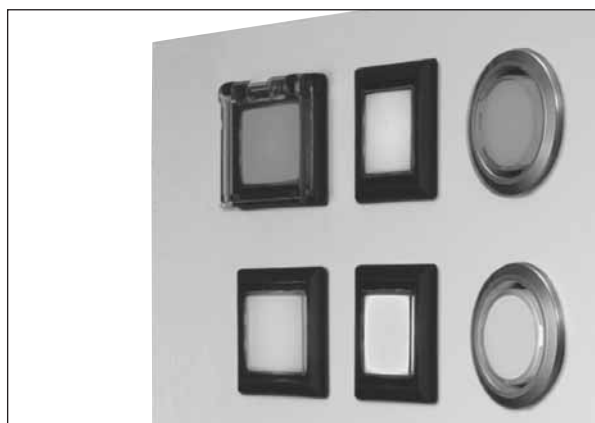



### • Applicable models

L6 Series	A6 Series
Illuminated Pushbutton	Illuminated Pushbutton
Pilot Light	Pilot Light
Pushbutton	Pushbutton
Selector Switch	Selector Switch
Key Selector Switch	Key Selector Switch
Illuminated Selector Switch	Illuminated Selector Switch
Lever Switch	
Buzzer	





Note: Flush silhouette bezels cannot be used for mushroom buttons or lenses.

## Flush Bezel

Shape	Specification	Type	Package Quantity	Remarks	
Flush Bezel	Round 	Metal (aluminum)	LA9Z-SM61	1	<ul style="list-style-type: none"> <li>• Degree of protection: IP65 (only when used with IP65 control units)</li> </ul>
	Round 	Plastic (black)	LA9Z-S61B	1	
	Square 	Plastic (black)	LA9Z-S71B	1	
	Rectangular 	Plastic (black)	LA9Z-S81B	1	
Switch Guard with Flush Bezel (Spring Return) Rectangular 	Plastic	LA9Z-KS8	1	<ul style="list-style-type: none"> <li>• Used for L6/A6 rectangular pushbuttons and illuminated pushbuttons. Cannot be used for selector switches, illuminated selector switches, and lever switches.</li> <li>• Degree of protection: IP65 (only when used with IP65 control units)</li> </ul>	
Rubber Boot	Round 	Round	LA9Z-DS6	1	<ul style="list-style-type: none"> <li>• Rubber boot is supplied with a flush bezel.</li> <li>• Degree of protection: IP65</li> <li>• Applicable type: L6/A6 pushbuttons and illuminated pushbuttons.</li> </ul>
	Square 	Square	LA9Z-DS7	1	
	Rectangular 	Rectangular	LA9Z-DS8	1	

Note: Terminal covers and maintenance parts for L6/A6 other than those shown above can also be used, except switch guard (AL-K) and rubber boot (AL-D).

# Flush Silhouette L6/A6 Series Accessories

Shape	Specification	Type	Package Quantity	Remarks
Round 	Plastic (black)	LA9Z-BS6	1	<ul style="list-style-type: none"> <li>Degree of protection: IP65</li> <li>Panel thickness: 0.5 to 5 mm</li> </ul>
Square 	Plastic (black)	LA9Z-BS7	1	
Rectangular 	Plastic (black)	LA9Z-BS8	1	

## Ordering Information

• Control units are not supplied with flush bezels. Order flush bezels separately.

## Specifications

• Based on L6/A6 series control unit specifications.

## Dimensions

### Flush Bezel

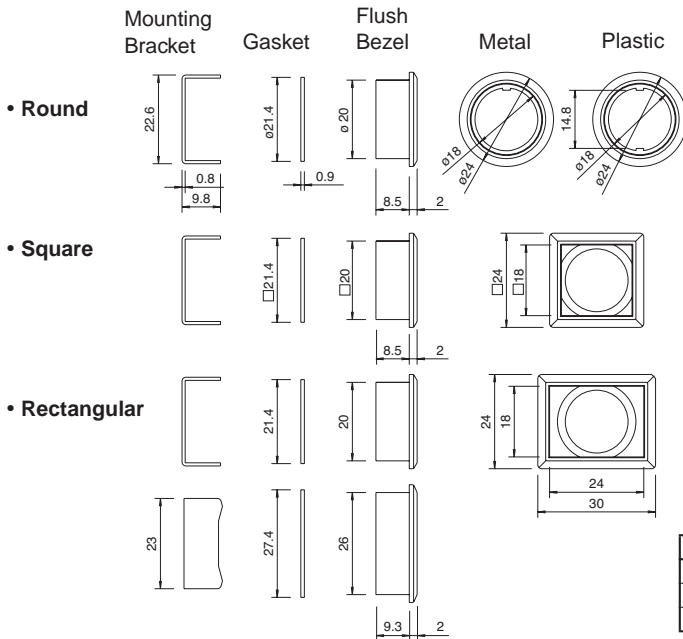

### Flush Bezel with Control Units

#### • L6 Series

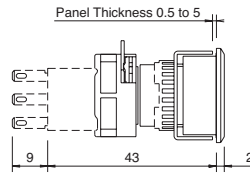

#### • A6 Series

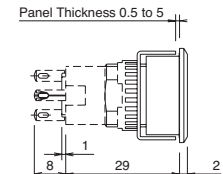

#### • Selector Switch • Illuminated Selector Switch

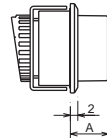

#### • Key Selector Switch

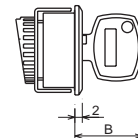

#### • Lever Switch L6 series

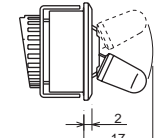

Unit	A (mm)
L6 selector switch	10.0
L6 illuminated selector	10.0
A6 selector switch	8.5

Unit	B (mm)
L6 key selector	18.1
A6 key selector	18.1

## Mounting Hole Layout

### • Round

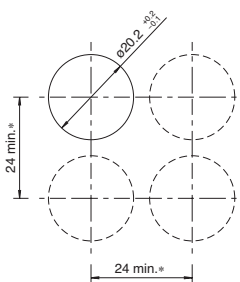

### • Square

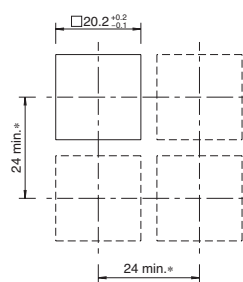

### • Rectangular

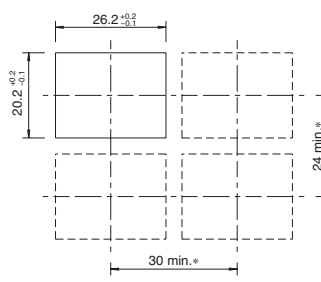

\*When mounting the rubber boot:  
 Round and square types: 27 mm minimum  
 Rectangular type: Vertical 27 mm, Horizontal 33 mm minimum

Mounting hole layout for the L6 series is the same for both straight-lever and L-lever contact types.

All dimensions in mm.



## Flush Bezel with Switch Guard

• L6 Series

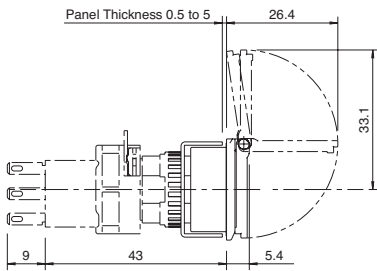

• A6 Series

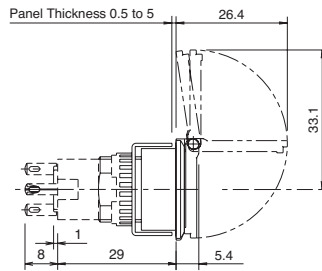

[Mounting Hole Layout]

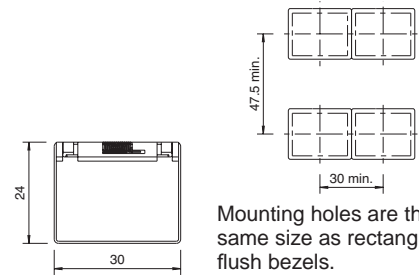

Mounting holes are the same size as rectangular flush bezels.

## Mounting Hole Plug

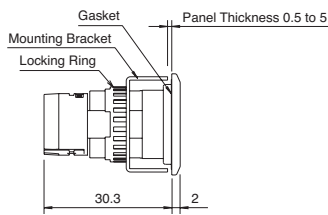

• Round

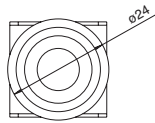

• Square

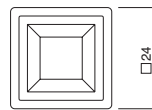

• Rectangular

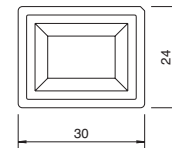

Mounting holes are the same size as flush bezels.

## Rubber Boot

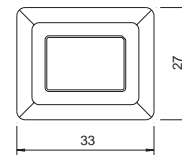
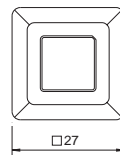
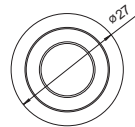
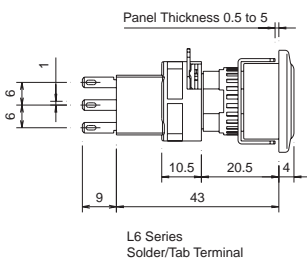

All dimensions in mm.

## Safety Precautions

- Turn off the power to the control units before installation, removal, wiring, maintenance, and inspection. Failure to turn power off may cause electrical shocks or fire hazard.
- To avoid burning your hand, use the lamp holder tool when replacing lamps.
- For wiring, use wires of a proper size to meet voltage and current requirements and solder correctly. Improper soldering may cause overheating and fire hazard. Also, when using tab terminals, use appropriate quick connect receptacles.

## Instructions

### Panel Mounting of Flush Bezels

#### • L6 series

1. Remove the contact block from the operator. Remove the locking ring and anti-rotation ring. To remove the operator from the contact block, turn the locking lever in the direction opposite to the arrow on the housing.
2. Attach the flush bezel to the operator. Then insert the assembly into the panel. Attach the mounting bracket and tighten the locking ring. (Do not use the anti-rotation ring supplied with the operator.)  
For round flush bezels, place the projection on the bezel to the groove on the TOP side of the operator and mount onto the panel.
3. Insert the contact block, with the TOP markings on the contact block and the operator placed in the same direction. Then lock the units, turning the locking lever in the direction of the arrow.

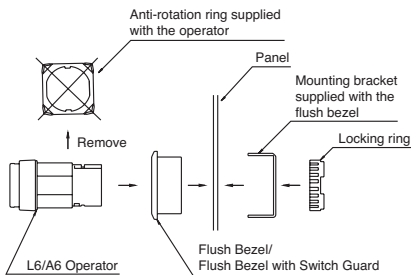

#### • A6 series

1. Remove the locking ring and anti-rotation ring from the operator.
2. Attach the flush bezel to the operator. Then insert the assembly into the panel. Attach the mounting bracket and tighten the locking ring. (Do not use the anti-rotation ring supplied with the operator.)  
For round flush bezels, place the projection on the bezel to the groove on the TOP side of the operator and mount onto the panel.

### Panel Mounting of Flush Bezels with Switch Guard

For installation, see Panel Mounting of Flush Bezels shown above.

### Installing the Rubber Boot

Attach the rubber boot and the flush bezel to the operator. Then insert the assembly into the panel. Attach the mounting bracket and tighten the locking ring. Tighten the locking ring to the recommended tightening torque of 0.88N·m. (Do not use the anti-rotation ring supplied with the operator.)

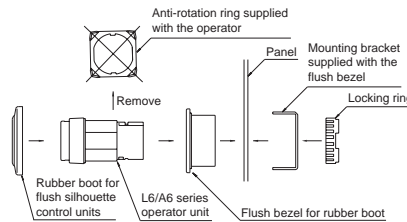

#### • Precautions for Installing the Rubber Boot

Install the rubber boot to wrap around the entire periphery of the flush bezel. Make sure that the projection on the rubber boot is placed into the groove on the back of the bezel. If the projection is not placed correctly, normal waterproof/dustproof characteristics will not apply.

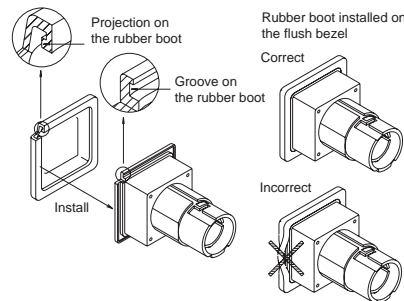

### Replacing the Lens

Remove the lens assembly (lens, marking plate, and lens holder) from the operator by holding the lens removal tool (MT-101) and pull out.



• For other instructions, refer to L6 and A6 series catalogs.



## L6 Series ø16mm Miniature Control Units

### Requires only a light touch.

### Collective mounting possible.

- Separate type control units with locking lever enable easy installation even when mounted collectively.
- Bright and clear LED illumination.
- Gold (gold-clad silver) or silver contacts; SPDT or DPDT
- Degree of protection: IP65
- UL recognized and CSA certified (except buzzers)  
EN compliant (except buzzers)  
(EN60947-1, EN60947-5-1, TÜV Rheinland)

### Contact Ratings

#### • Gold-clad Contacts

Maximum Voltage	250V AC/DC		
Thermal Current	3A		
Operating Voltage	125V AC	30V DC	
Operating Current	0.1A (resistive load)	0.1A (resistive load)	
Contact Material	Gold-clad silver		

#### • Silver Contacts

Operating Voltage		30V	125V	250V
Operating Current	AC 50/60Hz	Resistive Load	–	3A 2A
		Inductive Load	–	2A 1.5A
	DC	Resistive Load	2A	0.4A –
		Inductive Load	1A	0.2A –
Thermal Current		5A		
Contact Material		Silver		



### Major Specifications

- Mechanical Life Momentary: 2,000,000 operations  
Maintained, lever switch, selector switch: 250,000
- Electrical Life 100,000 operations
- Degree of Protection IP65 (IEC 62529)
- Terminal Style Solder/tab terminal #110  
PC board terminal

## A6 Series ø16mm Miniature Control Units

### Light Duty, Unibody Type.

- Bright and clear LED illumination.
- Gold (gold-clad silver) contacts; SPDT or DPDT
- Degree of protection: IP65 or IP40
- UL recognized and CSA certified. EN compliant

### Contact Ratings

Maximum Voltage		250V			
Thermal Current		3A			
Operating Voltage		12V	24V	110V	220V
Operating Current	AC 50/60Hz	Resistive Load	–	–	1.0A 0.5A
		Inductive Load	–	–	0.7A 0.5A
	DC	Resistive Load	1.0A	1.0A	0.2A –
		Inductive Load	0.7A	0.7A	0.1A –
Contact Material		Gold-clad silver			



### Major Specifications

- Mechanical Life Momentary: 1,000,000 operations  
Maintained, pushlock turn reset: 10,000  
Selector switch, key selector switch: 250,000
- Electrical Life Maintained: 50,000 operations  
Others: 100,000 operations  
(1,200 operations /hour)
- Degree of Protection IP65 (waterproof/oiltight type)  
IP40 (enclosed type)
- Terminal Style Solder/tab terminal #110

Specifications and other descriptions in this catalog are subject to change without notice.



## IDEC CORPORATION

7-31, Nishi-Miyahara 1-Chome, Yodogawa-ku, Osaka 532-8550, Japan  
Tel: +81-6-6398-2571, Fax: +81-6-6392-9731  
E-mail: products@idec.co.jp

**IDEC CORPORATION (USA)**  
1175 Elko Drive, Sunnyvale, CA 94089-2209, USA  
Tel: +1-408-747-0550 / (800) 262-IDECC (4332)  
Fax: +1-408-744-9055 / (800) 635-6246  
E-mail: opencontact@idec.com

**IDEC CANADA LIMITED**  
Unit 22-151, Brunel Road, Mississauga, Ontario,  
L4Z 1X3, Canada  
Tel: +1-905-890-8561, Toll Free: (888) 317-4332  
Fax: +1-905-890-8562  
E-mail: sales@ca.idec.com

**IDEC AUSTRALIA PTY. LTD.**  
2/3 Macro Court, Rowville, Victoria 3178, Australia  
Tel: +61-3-9763-3244, Toll Free: 1800-68-4332  
Fax: +61-3-9763-3255  
E-mail: sales@au.idec.com

**IDEC ELECTRONICS LIMITED**  
Unit 2, Beechwood, Chineham Business Park,  
Basingstoke, Hampshire RG24 8WA, UK  
Tel: +44-1256-321000, Fax: +44-1256-327755  
E-mail: sales@uk.idec.com

**IDEC ELEKTROTECHNIK GmbH**  
Wendenstrasse 331, 20537 Hamburg, Germany  
Tel: +49-40-25 30 54 - 0, Fax: +49-40-25 30 54 - 24  
E-mail: service@idec.de

**IDEC (SHANGHAI) CORPORATION**  
Room 608-609, 6F, Gangtai Plaza, No. 700,  
Yan'an East Road, Shanghai 200001, PRC  
Tel: +86-21-5353-1000, Fax: +86-21-5353-1263  
E-mail: idec@cn.idec.com

**IDEC (BEIJING) CORPORATION**  
Room 211B, Tower B, The Grand Pacific Building,  
8A Guanghua Road, Chaoyang District,  
Beijing 100026, PRC  
Tel: +86-10-6581-6131, Fax: +86-10-6581-5119

**IDEC (SHENZHEN) CORPORATION**  
Unit AB-3B2, Tian Xiang Building, Tian'an Cyber Park,  
Fu Tian District, Shenzhen, Guang Dong 518040, PRC  
Tel: +86-755-8356-2977, Fax: +86-755-8356-2944

**IDEC IZUMI (H.K.) CO., LTD.**  
Unit 1505-07, DCH Commercial Centre No. 25,  
Westlands Road, Quarry Bay, Hong Kong  
Tel: +852-2803-8989, Fax: +852-2565-0171  
E-mail: info@hk.idec.com

**IDEC TAIWAN CORPORATION**  
8F-1, No. 79, Hsin Tai Wu Road, Sec. 1,  
Hsi-Chih, Taipei County, Taiwan  
Tel: +886-2-2698-3929, Fax: +886-2-2698-3931  
E-mail: service@idectwn.com.tw

**IDEC IZUMI ASIA PTE. LTD.**  
No. 31, Tannery Lane #05-01, Dragon Land  
Building, Singapore 347788  
Tel: +65-6746-1155, Fax: +65-6844-5995  
E-mail: info@sg.idec.com