

POSIWIRE® WS31C Analog Output

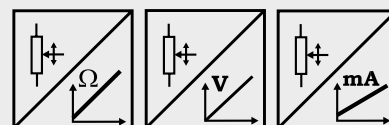

Compact OEM sensor for large order volumes

- Protection class IP50
- Economical design
- Compact outline
- Measurement range 0 ... 250 mm to 0 ... 750 mm
- Mounting optional with mounting brackets or spacer nuts with internal thread
- Analog output



Specifications	Outputs	Potentiometer 1 kΩ Voltage 0.5 ... 10 V Current 4 ... 20 mA, 2 wire
	Resolution	Essentially infinite
	Linearity	±0.35% f.s., other values on request
	Sensing device	Precision potentiometer
	Material	Housing: plastic; cable drum: aluminum; cable: stainless steel
	Protection class	IP50
	Connection	Cable output, standard length 2 m
	Temperature	-15 ... +60 °C, max. 85 % r. h., non condensing
	Weight	Approx. 90 g
	Pull-out force	250 mm: 1.5 N 500 mm: 1.7 N 750 mm: 1.2 N
	EMC	Refer to output specification

Order code WS31C

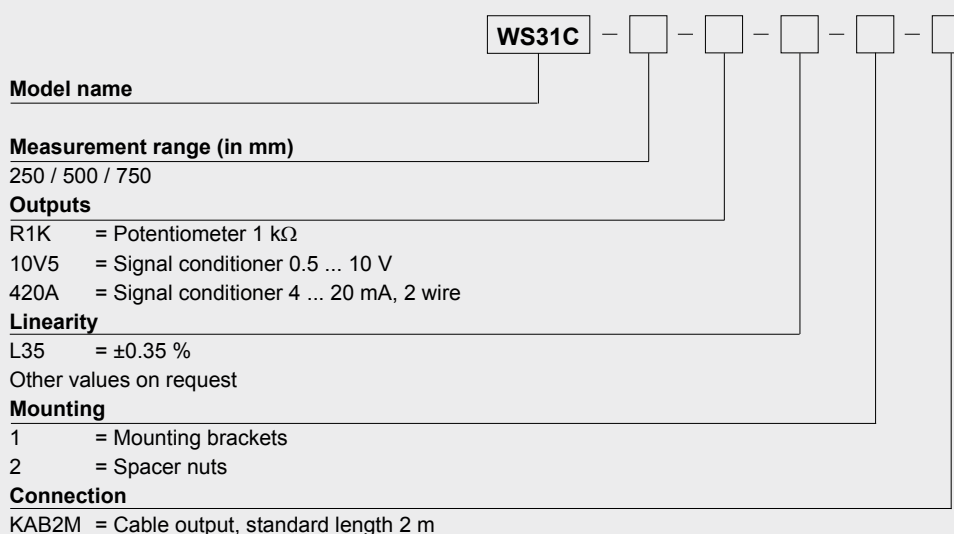

Order example: WS31C - 250 - 420A - L35 - 1 - KAB2M

POSIWIRE®
WS31C
Analog Output



Outline drawing

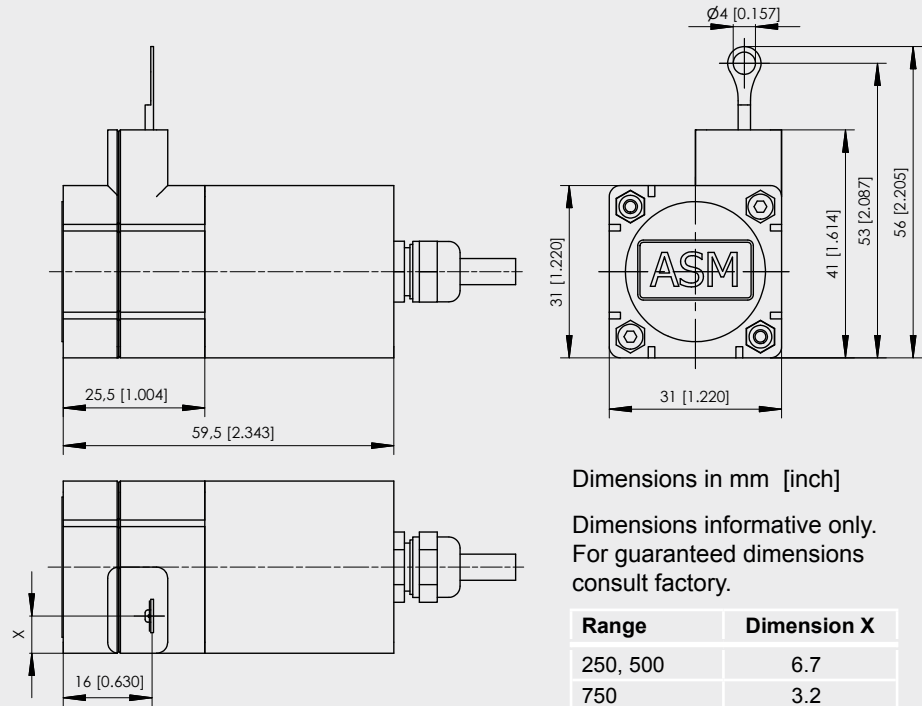

Mounting with mounting brackets

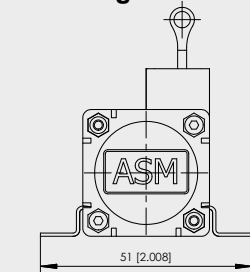

Mounting with spacer nuts

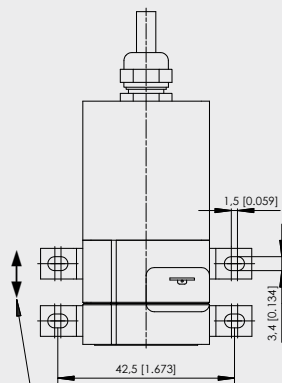
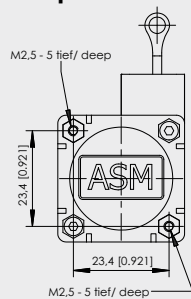

All mounting brackets are moveable along the whole groove while not fixed

Mounting bracket WS31-BFW1

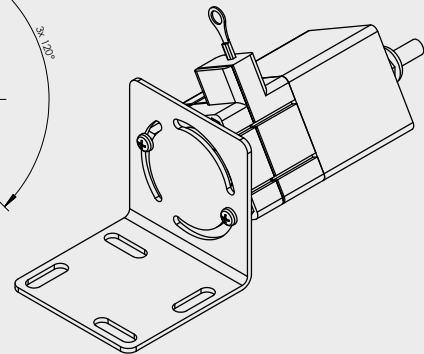
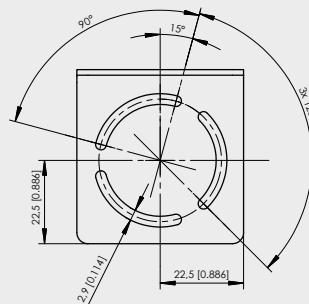
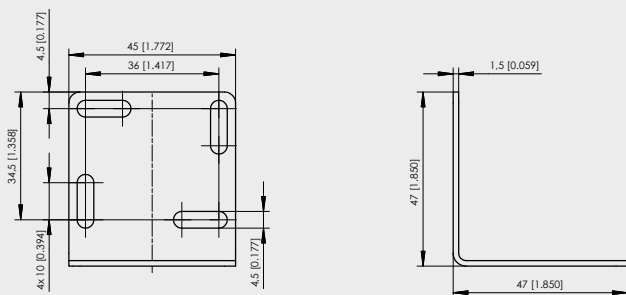

POSIWIRE® WS42C Analog Output



Compact OEM sensor for large order volumes

- Protection class IP50
- Economical design
- Compact outline
- Measurement range 0 ... 750 mm and 0 ... 1000 mm
- Mounting optional with mounting brackets or spacer nuts with internal thread
- Analog output

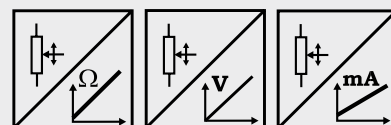

Specifications	Outputs	Potentiometer 1 kΩ Voltage 0.5 ... 10 V Current 4 ... 20 mA, 2 wire
	Resolution	Essentially infinite
	Linearity	±0.35% f.s., other values on request
	Sensing device	Precision potentiometer
	Material	Housing: plastic; cable drum: aluminum; cable: stainless steel
	Protection class	IP50
	Connection	Cable output, standard length 2 m
	Temperature	-15 ... +60 °C, max. 85 % r. h., non condensing
	Weight	Approx. 125 g
	Pull-out force	750 mm: 2.5 N 1000 mm: 1.7 N
	EMC	Refer to output specification

Order code WS42C



Model name

Measurement range (in mm)

750 / 1000

Outputs

R1K = Potentiometer 1 kΩ

10V5 = Signal conditioner 0.5 ... 10 V

420A = Signal conditioner 4 ... 20 mA, 2 wire

Linearity

L35 = ±0.35 %

Other values on request

Mounting

1 = Mounting brackets

2 = Spacer nuts

Connection

KAB2M = Cable output, standard length 2 m

Order example: WS42C - 750 - 420A - L35 - 1 - KAB2M

POSIWIRE®
WS42C
Analog Output



Outline drawing

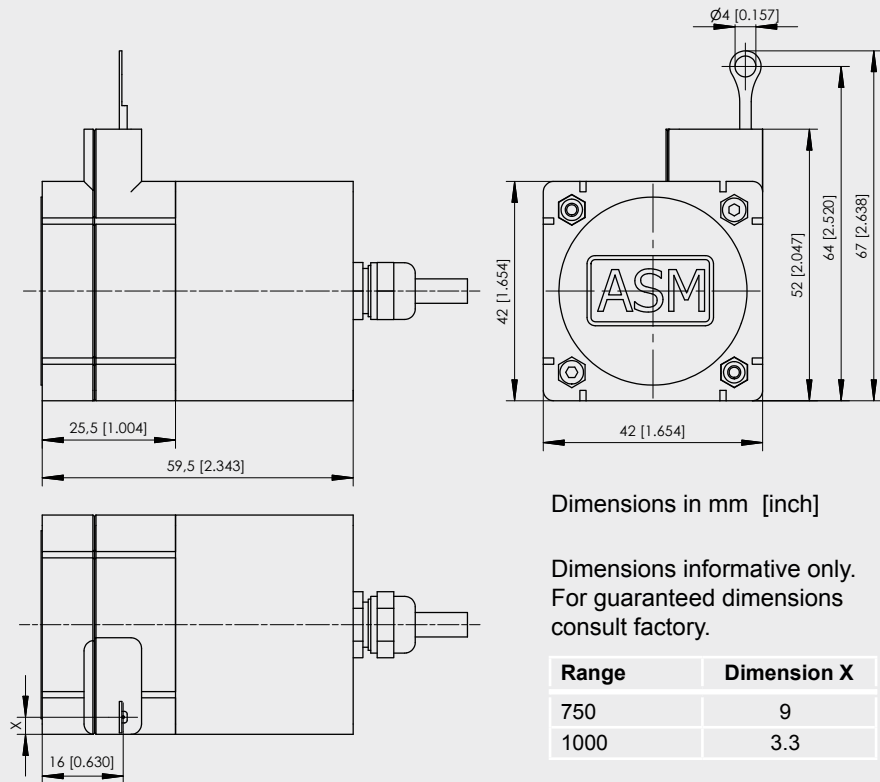

**Mounting with
 mounting brackets**

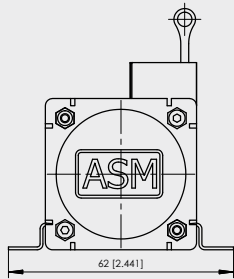

**Mounting with
 spacer nuts**

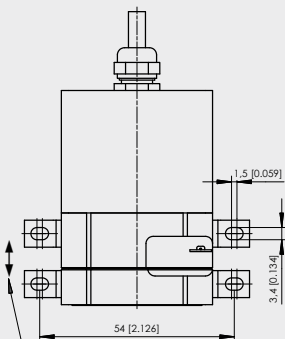
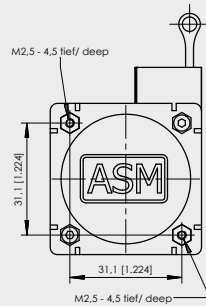

All mounting brackets are moveable along the whole groove while not fixed

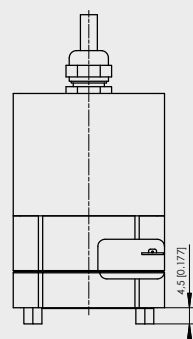

**Mounting bracket
 WS42-BFW1**

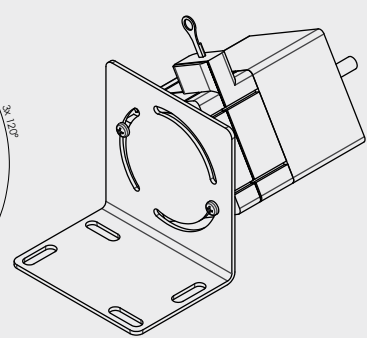
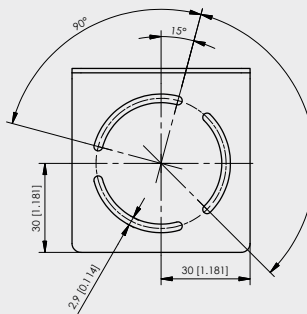
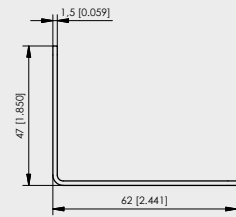
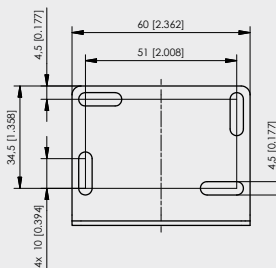

POSIWIRE® WS31 Incremental Encoder Output



Compact OEM sensor for large order volumes

- Protection class IP50
- Economical design
- Compact outline
- Measurement range 0 ... 500 mm
- Resolution 10 pulses per mm
- Mounting optional with mounting brackets or spacer nuts with internal thread
- Incremental encoder output

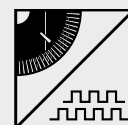

Specifications		
Output	Incremental encoder	
Resolution	10 pulses per mm	
Linearity	±0.20% f.s., other values on request	
Sensing device	Incremental encoder	
Material	Housing: plastic; cable drum: aluminum; cable: stainless steel	
Protection class	IP50	
Connection	Cable output radial, length approx. 3 m	
Temperature	0 ... +60 °C, max. 85 % r.h., non condensing	
Weight	Approx. 95 g	
Pull-out force	1.5 N	
EMC	Refer to output specification	

Order code WS31

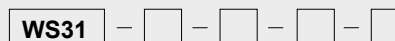

Model name

Measurement range (in mm)

500

Pulses per mm

10

Outputs

IE24LI = Incremental output TTL compatible

IE24HI = Incremental output HTL compatible

Mounting

1 = Mounting brackets

2 = Spacer nuts

Order example: WS31 - 500 - 10 - IE24HI - 1

POSIWIRE®
WS31
Incremental Encoder Output



Outline drawing

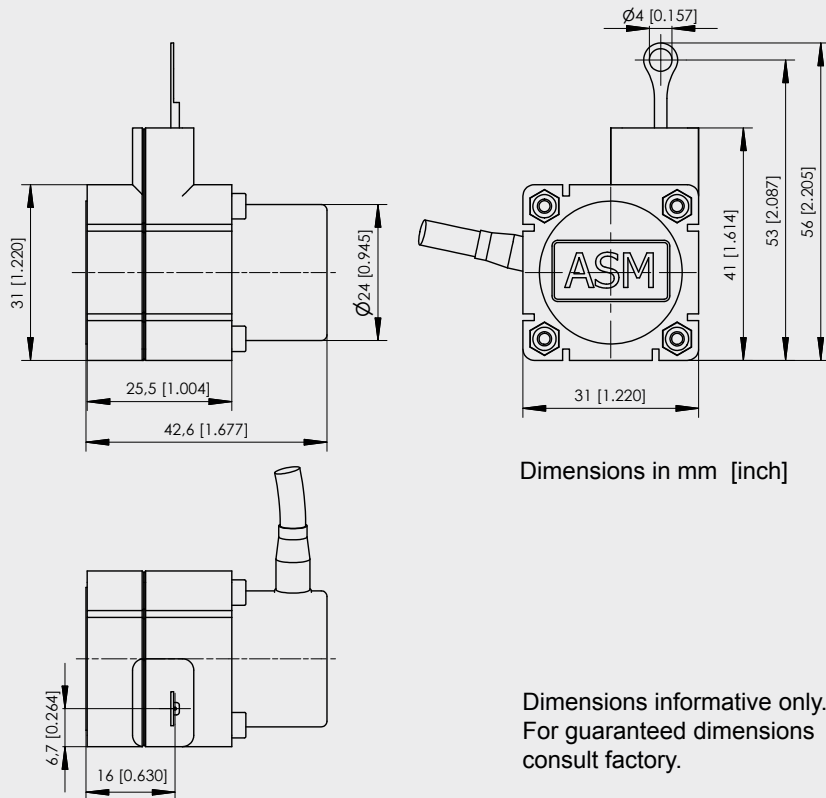

Mounting with mounting brackets

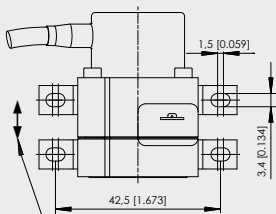
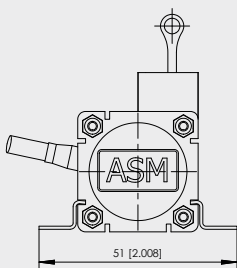

All mounting brackets are moveable along the whole groove while not fixed

Mounting with spacer nuts

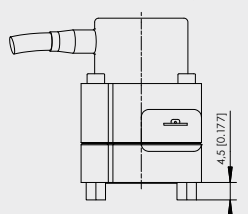
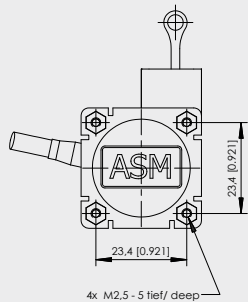

Mounting bracket WS31-BFW1

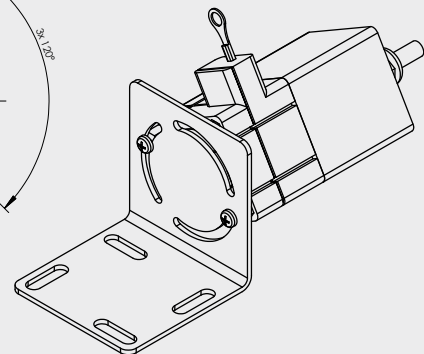
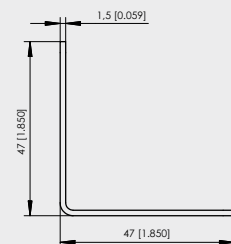
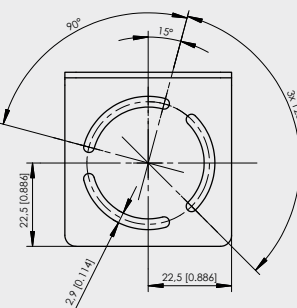
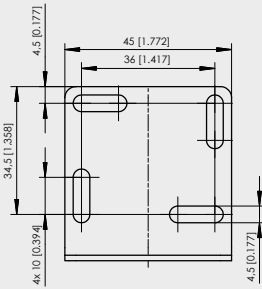

POSIWIRE®
WS42
Incremental Encoder Output



Compact OEM sensor for large order volumes

- Protection class IP50
- Economical design
- Compact outline
- Measurement range 0 ... 1000 mm
- Resolution 6 pulses per mm
- Mounting optional with mounting brackets or spacer nuts with internal thread
- Incremental encoder output

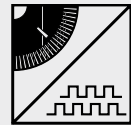

Specifications	Output	Incremental encoder
	Resolution	6 pulses per mm
	Linearity	±0.20% f.s., other values on request
	Sensing device	Incremental encoder
	Material	Housing: plastic; cable drum: aluminum; cable: stainless steel
	Protection class	IP50
	Connection	Cable output radial, length approx. 3 m
	Temperature	0 ... +60 °C, max. 85 % r.h., non condensing
	Weight	Approx. 130 g
	Pull-out force	1.7 N
EMC	Refer to output specification	

Order code WS42

Model name

Measurement range (in mm)

500

Pulses per mm

6

Outputs

IE24LI = Incremental output TTL compatible

IE24HI = Incremental output HTL compatible

Mounting

1 = Mounting brackets

2 = Spacer nuts

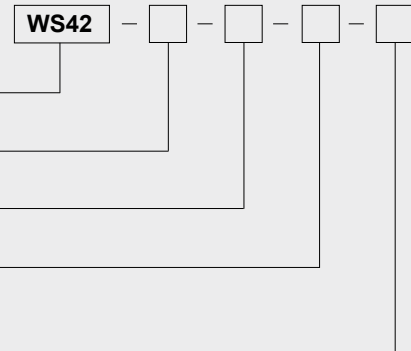

Order example: WS42 - 1000 - 6 - IE24LI - 1

POSIWIRE®
WS42
Incremental Encoder Output



Outline drawing

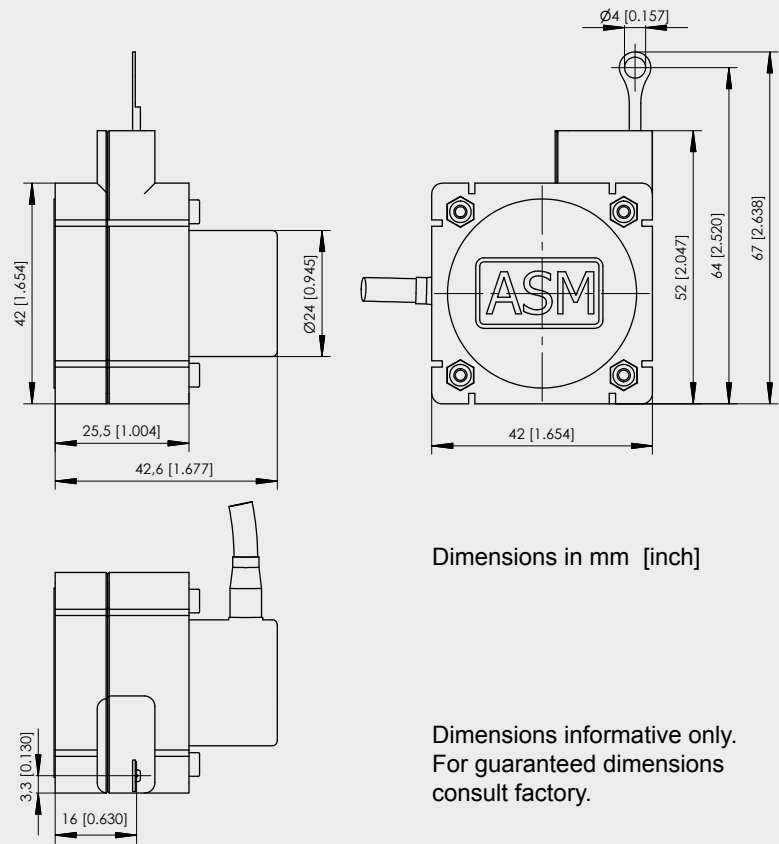

**Mounting with
 mounting brackets**

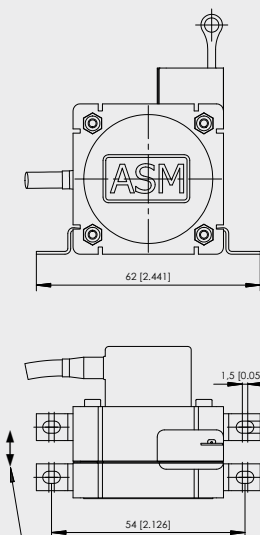

All mounting brackets are
 moveable along the whole
 groove while not fixed

**Mounting with
 spacer nuts**

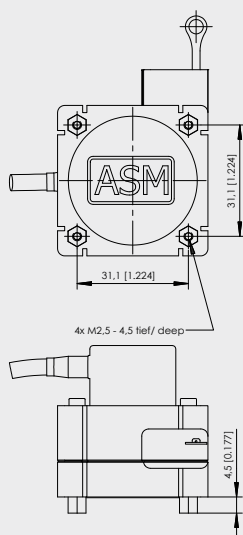

**Mounting bracket
 WS42-BFW1**

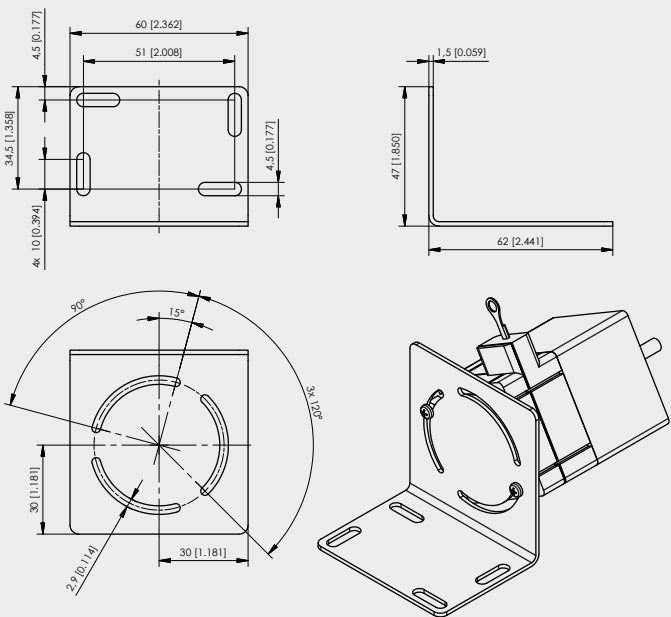

POSIWIRE® R1K and 10V Analog Output



Voltage divider R1K Potentiometer 	Excitation voltage	32 V DC max. at 1 kΩ (max. power 1 W)
	Potentiometer impedance	1 kΩ ±10 %
	Thermal coefficient	±25 x 10 ⁻⁶ / °C f.s.
	Sensitivity	Depends on the measuring range, individual sensitivity of the sensor is specified on the label
	Voltage divider utilization range	Approx. 3 % ... 97 %
	Operating temperature	-20 ... +85 °C

Output signals

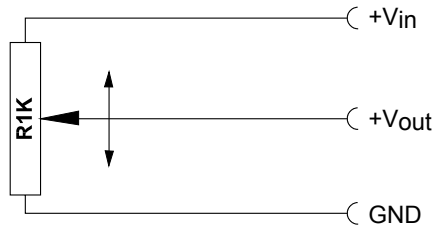

Note: The Potentiometer must be connected as a voltage divider. The input impedance of the following processing circuit should be 10 MΩ min.

Signal conditioner 10V and 10V5 Voltage output 	Excitation voltage	18 ... 27 V DC non stabilized
	Excitation current	20 mA max.
	Output voltage	10V: 0 ... 10 V DC; 10V5: 0.5 ... 10 V DC
	Output current	2 mA max.
	Output load	> 5 kΩ
	Stability (temperature)	±50 x 10 ⁻⁶ / °C f.s.
	Protection	Reverse polarity, short circuit
	Output noise	0.5 mV _{RMS}
	Operating temperature	-20 ... +85 °C
	EMC	According EN 61326:2006

Output signals



Signal wiring	Signal name R1K	10V	Cable color	Connector pin no.
	+Vin	Excitation + +	White	1
	GND	Excitation GND	Brown	2
	+Vout	Signal +	Green	3
		Signal GND	Yellow	4

Connection

View to sensor connector

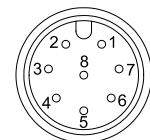

CONN-M12-8F

POSIWIRE® 420A and 420T Analog Output



Signal conditioner 420A Current output (2 wire) 	Excitation voltage	12 ... 27 V DC non stabilized, measured at the sensor terminals
	Excitation current	35 mA max.
	Output current	4 ... 20 mA equivalent for 0 ... 100 % range
	Stability (temperature)	$\pm 100 \times 10^{-6} / ^\circ\text{C}$ f.s.
	Protection	Reversed polarity, short circuit
	Output noise	0.5 mV _{RMS}
	Operating temperature	-20 ... +85 °C
	EMC	According to EN 61326:2006

Output signals

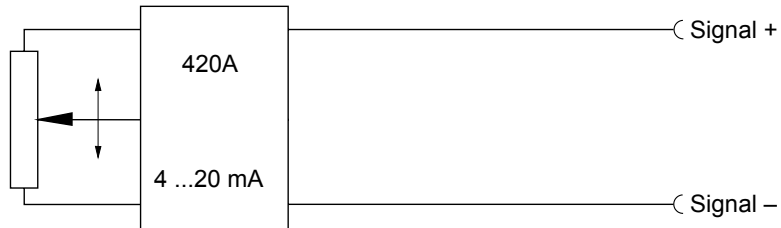

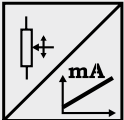
Signal conditioner 420T Current output (3 wire) 	Excitation voltage	18 ... 27 V DC non stabilized
	Excitation current	40 mA max.
	Load resistor	350 Ω max.
	Output current	4 ... 20 mA equivalent for 0 ... 100 % range
	Stability (temperature)	$\pm 50 \times 10^{-6} / ^\circ\text{C}$ f.s.
	Protection	Reverse polarity, short circuit
	Output noise	0.5 mV _{RMS}
	Operating temperature	-20 ... +85 °C
	EMC	According to EN 61326:2006

Output signals



Signal wiring	Signal name		Cable color	Connector pin no.
	420A	420T		
Signal +		Excitation +	White	1
Signal -		Excitation GND	Brown	2
		Signal +	Green	3

Connection

View to sensor
connector

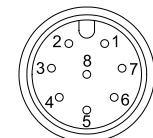

CONN-M12-8F

POSIWIRE®

IE24LI and IE24HI

Incremental Output



Signal conditioner IE24LI and IE24HI Incremental



	IE24LI	IE24HI
Excitation voltage	5 V DC $\pm 10\%$	10 ... 30 V DC
Excitation current	100 mA max.	
Output frequency	200 kHz max.	
Output	Push pull and inverted signals	
Output current	10 mA max.	
Output voltage	Depending on the excitation voltage	
Stability (temperature)	$\pm 20 \times 10^{-6}$ / °C f.s. (sensor mechanism)	
Operating temperature	-20 ... +85 °C	
Protection	Short circuit	
EMC	According to EN 61326:2006	

Output signals

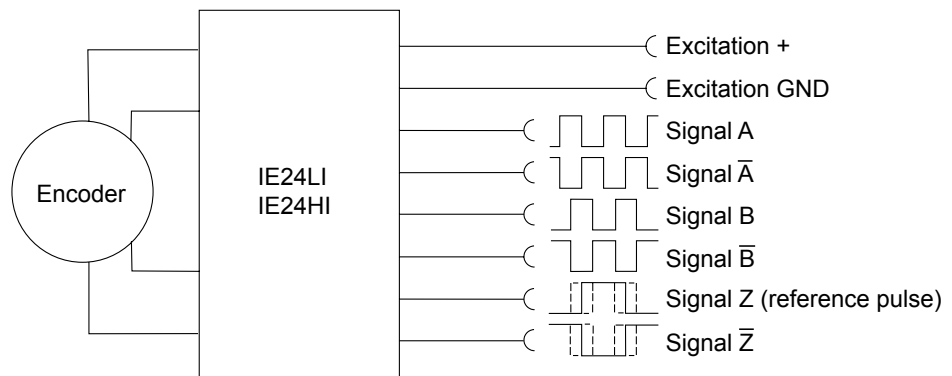

Recommended processing circuit

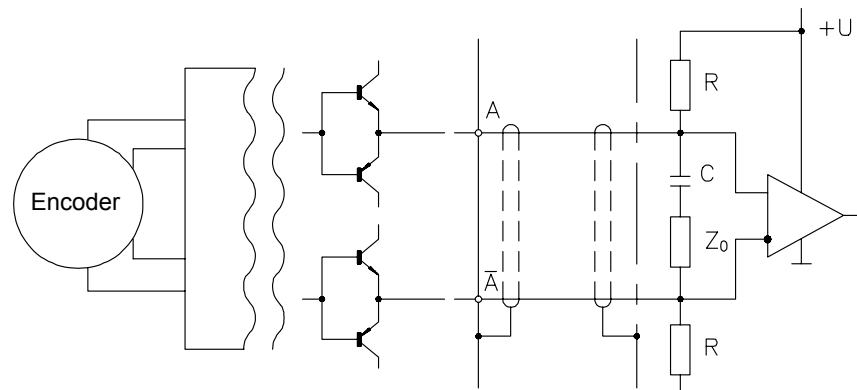

Signal wiring	Signal name	Cable color (WS31/42)
	Excitation +	Brown
	Excitation GND (0 V)	White
	Signal A	Green
	Signal \bar{A}	Yellow
	Signal B (A + 90°)	Grey
	Signal \bar{B}	Pink
	Signal Z (reference pulse)	Blue
	Signal \bar{Z}	Red