

Datasheet

Subject to technical alteration
Issue date: 05.11.2018 • A001



Application

FSR humidistats are designed for the on/off control of ventilation and air conditioning, humidification and dehumidification equipment in room applications.

Types Available

Room hygrostat

FSR01
FSR01-I (internal adjuster)

Security Advice – Caution



The installation and assembly of electrical equipment should only be performed by authorized personnel.

The product should only be used for the intended application. Unauthorised modifications are prohibited! The product must not be used in relation with any equipment that in case of a failure may threaten, directly or indirectly, human health or life or result in danger to human beings, animals or assets. Ensure all power is disconnected before installing. Do not connect to live/operating equipment.



CAUTION! Risk of electric shock due to live components within the enclosure, especially devices with mains voltage supply (usually between 90..265 V).

Please comply with

- Local laws, health & safety regulations, technical standards and regulations
- Condition of the device at the time of installation, to ensure safe installation
- This data sheet and installation manual

Notes on Disposal



As a component of a large-scale fixed installation, Thermokon products are intended to be used permanently as part of a building or a structure at a pre-defined and dedicated location, hence the Waste Electrical and Electronic Act (WEEE) is not applicable. However, most of the products may contain valuable materials that should be recycled and not disposed of as domestic waste. Please note the relevant regulations for local disposal.

Technical Data

Measuring values	humidity
Medium	air
Output switch contact	change over contact, floating dehumidifying, max. 250 V, 5 (1) A, min. 100 mA* humidifying, max. 250 V, 3 (1) A, min. 100mA* *Minimum switching current 100mA, not relevant when switching high-impedance loads (> 10kOhm) like logic levels
Measuring range humidity	30..100 % rH non-condensing
Working range humidity	35..95% rH
Accuracy humidity	±3% rH (typ. at 50% rH) Average temperature coefficient -0,2% / K, typ at 20 °C, 50% rH
Sensor	plastic fibers
Enclosure	PC, pure white
Protection	IP30 according to EN 60529
Cable entry	breaking points top/bottom, rear entry
Connection electrical	terminal block, max. 1,5 mm ²
Ambient condition	0..+60 °C
Mounting	surface mounted on flush-mounting box (Ø=60 mm), to be mounted flat onto the surface using adhesive foil or screws, with frame for surface mounting (accessory) or directly on the wall, base part can be mounted and wired separately
Notes	threshold adjustment via potentiometer or internal adjuster



Declaration of conformity

The declaration of conformity of the products can be found on our website <https://www.thermokon.de/>.

Terminal Connection Plan

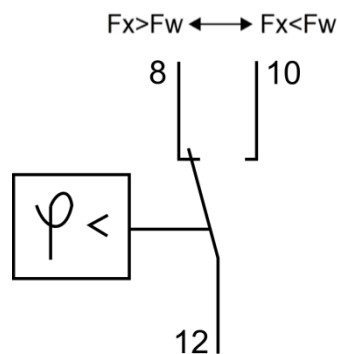
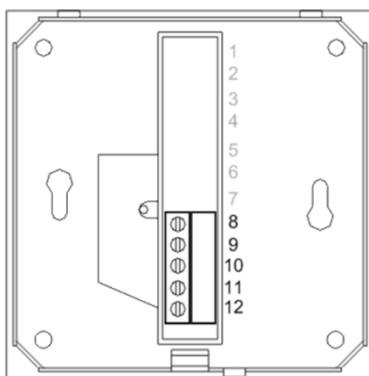

Fx: rel. humidity of the air (actual value)
Fw: humidity adjusted with the wheel (set point)

If the rel. humidity Fx (actual value) decreases below set point value Fw, contact 8/12 will open and contact 10/12 will close.

Typical switching differential with typical tolerance

Hysteresis (switching difference)		
90% rH	3% rH	±1% rH
80% rH	3% rH	±1% rH
70% rH	4% rh	±1,5% rH
60% rh	4% rH	±1,5% rH
50% rH	5% rH	±1,5% rH

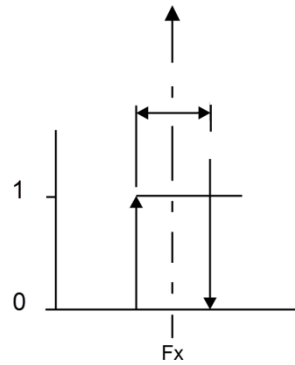

Internal Set point adjustment (FSR01-I)

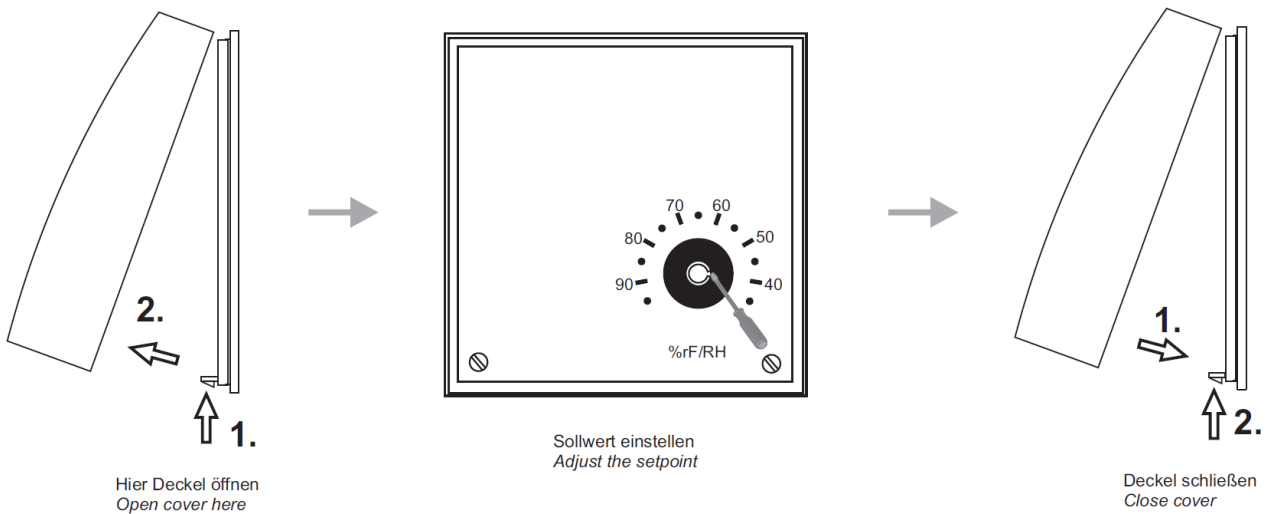

Description of the hygostat

The humidity measuring element consists of several plastic fabric bands each with 90 individual fibres with a diameter of 3 µm each. The fibres are provided with hygroscopic characteristics by a special process. The measuring element adsorbs and desorbs moisture. The effect, swelling predominantly in longitudinal direction, is transmitted via a lever system to a microswitch with a small switching distance. The measuring element responds to the change in air humidity. It is possible to adjust the lever system by setting the adjustment knob so that the microswitch is actuated when the set air humidity is reached.

The fan shaped measuring element is accomodated inside the housing and must be protected against coarse dust, dirt and water. The humidistats are designed for pressureless systems. The installation location must be selected so that condensed water cannot enter the inside of the housing. The installation position preferably with ventilation slots at right-angles to wind direction.

Mounting Advices

Make sure that the device is power-off, if you install it!

The device can be installed on a smooth wall surface or a flush box. It should be selected a representative location for the measuring medias. The use of deep installation boxes is recommended due to the increased storage capacity for the cabling.

Sunlight and drafts e.g. in conduit must be avoided so that the measuring result is not distorted. If necessary, is the end of the installation tube seal

(1) For wiring, the upper part of the base plate must be solved. Base plate and upper part are connected with each other by mounting clips.

(2) The installation of the base plate to the smooth wall surface can be done with plugs and screws.

(3) Then, the device is placed on the base plate.

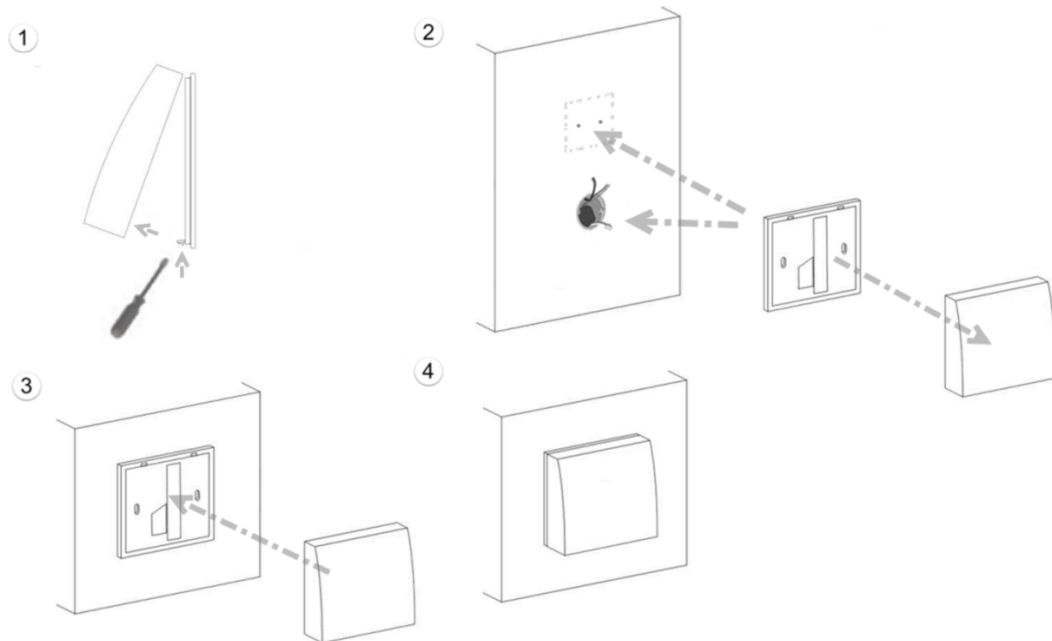

Dimensions (mm)

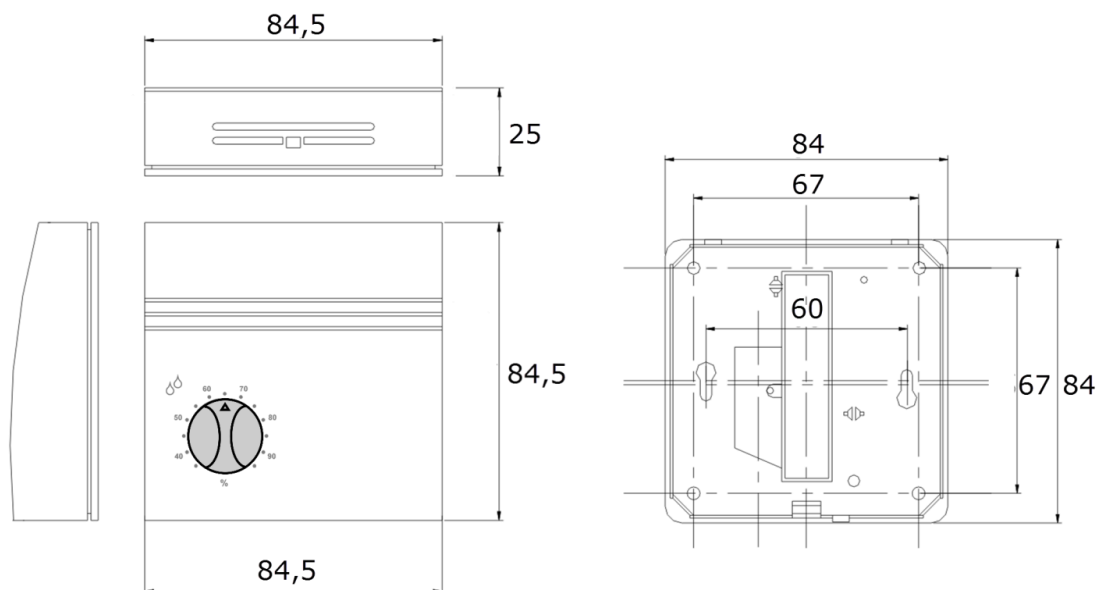

Accessories (optional)

Rawl plugs and screws (2 pcs. each)
Frame for surface mounting WRF04

Item No. 102209
Item No. 111584