

Datasheet

Subject to technical alteration
Issue date: 6/18/2019 • A100



» APPLICATION

Hygrostat (ON-OFF controller) to control the relative air humidity. It is designed for applications, where air humidity has to be controlled or monitored as ventilation and air conditioning, humidification and dehumidification equipment, in offices and computer rooms, food stores, cooling rooms for fruit and vegetables, greenhouses for gardening use, textile industry, paper and printing industry, film industry, hospitals and similar applications.

» SECURITY ADVICE – CAUTION



The installation and assembly of electrical equipment should only be performed by authorized personnel.

The product should only be used for the intended application. Unauthorised modifications are prohibited! The product must not be used in relation with any equipment that in case of a failure may threaten, directly or indirectly, human health or life or result in danger to human beings, animals or assets. Ensure all power is disconnected before installing. Do not connect to live/operating equipment.



CAUTION! Risk of electric shock due to live components within the enclosure, especially devices with mains voltage supply (usually between 90..265 V).

Please comply with

- Local laws, health & safety regulations, technical standards and regulations
- Condition of the device at the time of installation, to ensure safe installation
- This data sheet and installation manual

» NOTES ON DISPOSAL



As a component of a large-scale fixed installation, Thermokon products are intended to be used permanently as part of a building or a structure at a pre-defined and dedicated location, hence the Waste Electrical and Electronic Act (WEEE) is not applicable. However, most of the products may contain valuable materials that should be recycled and not disposed of as domestic waste. Please note the relevant regulations for local disposal.

» TECHNICAL DATA

Measuring values	humidity	
Medium	air, non-pressurized, non-aggressive	
Output switch contact	switching difference, 4% rH (at 50% rH), change over contact , floating for 230 V ~ / 2 A (inductive), 230 V ~ / 15 A (resistive)	
Measuring range humidity	30..100 % rH non-condensing	
Working range humidity	35..95% rH	
Accuracy humidity	typ. $\pm 3,5\%$ (>50% rH), $\pm 4\%$ (<50% rH) Average temperature coefficient 0,2% / K, typ at 20 °C (68 °F), 50% rH	
Air speed	max. 8 m/s (26 ft./s), with filter protection max. 15 m/s (50 ft./s)	
Sensor	Polyga® measuring element, water resistant, washable	
Enclosure	ABS, pure white, light grey	
Protection (type-dependent)	FSK01 IP54 according to EN 60529	FSK01 internal adjuster IP64 according to EN 60529
Cable entry	M20 for wire max. $\varnothing=0.31$ in.	
Connection electrical	terminal block, max. AWG16	
Pipe	stainless steel, $\varnothing=0.63$ in., length 8.66 in.	
Filter optional	PTFE filter for extreme operating conditions	Filter protection wire mesh for flow rates 8..15 m / s (26..50 ft./s)
Ambient condition	0..+60 °C (+32..+140 °F)	
Mounting	Installation position: Sensor vertically downwards or horizontally	

» PRODUCT TESTING AND CERTIFICATION



Declaration of conformity

The declaration of conformity of the products can be found on our website <https://www.thermokon.de/>.

» TERMINAL CONNECTION PLAN

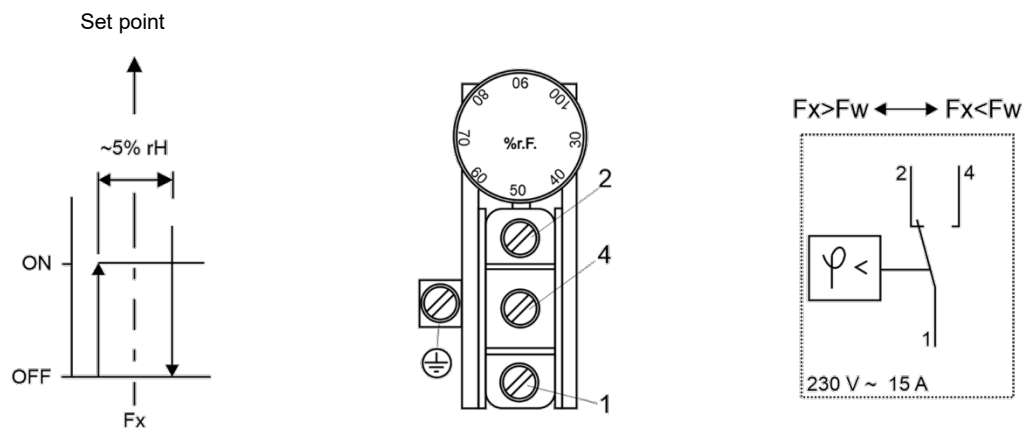

Fx rel. humidity of the air (actual value)
Fw humidity adjusted with the wheel (set point)

If the rel. humidity Fx (actual value) decreases below set point value Fw, contact 1/2 will open and contact 1/4 will close.



When installing the device please ensure, that there is sufficient overcurrent protection (e.g. fuse). A separation device (e.g. plug or switch) has to be installed.

» MOUNTING ADVICES

The hygrostat must not be exposed to any direct water contact, e.g. splash water when cleaning the air-conditioned room. When choosing the mounting place a representative air humidity measurement has to be regarded (measured humidity values at the mounting place should correspond to those of the room as far as possible). The hygrostat should be located within the air flow.

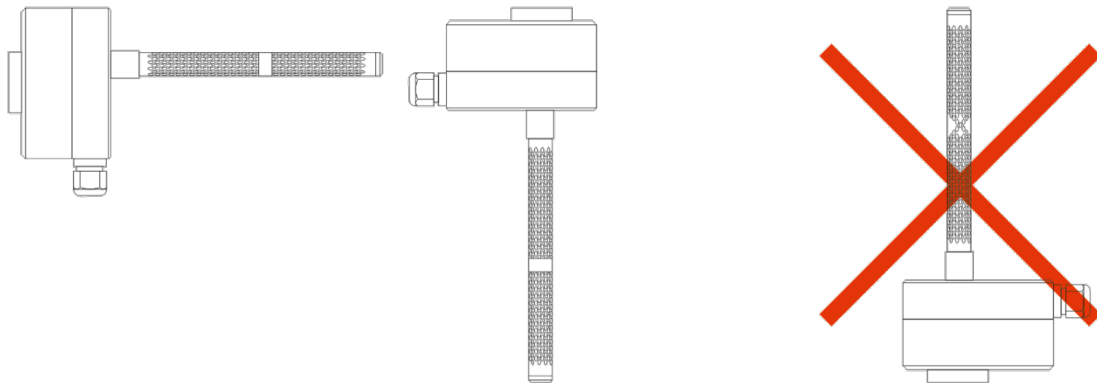

Condensed water must not get into the interior of the enclosure.

» DESCRIPTION OF THE HYGROSTAT

The humidity measuring element consists of several plastic fabric bands each with 90 individual fibers with a diameter of 3µm each. The fibers are provided with hygroscopic characteristics by a special process. The measuring element absorbs and desorbs moisture. The effect, swelling predominantly in longitudinal direction, is supplied to a micro switch with an extremely low switching travel via a suitable lever system. The measuring element responds rapidly and precisely to the change in air humidity. It is possible to adjust the lever system by setting the set point knob so that the micro switch is actuated when the set air humidity is reached.

The fan shaped measuring element is protected by a perforated sensor tube and is exposed to the housing. The hygrostats are designed for pressure-less systems. The mounting position should be chosen such that condensed water cannot get into the interior of the housing. The preferred mounting position is with the „sensor vertically with pipe down“ or „sensor horizontal“ (see mounting advices). In the mounting positions described above, a blanking plate in the sensor tube with a 0.3 in. diameter hole will prevent water getting in.

Operating information: When working within the upper range of operation, possible tolerances (measurement accuracy, switching difference and temperature coefficient) should be observed when adjusting the switch point.

Note: Moving the adjuster screw will result in an expiration of warranty and guarantee.

» MAINTENANCE

The measuring element is **maintenance-free** in pure ambient air. Aggressive media containing solvent can cause measuring errors and failure, depending on the type and concentration. As with almost all humidity measuring elements, deposits which eventually form a water-repellent film over the sensor are harmful. Such substances are resin aerosols, lacquer aerosols, smoke deposits etc. The water-resistant property of the measuring elements allows cleaning to be carried out in water. Solvents cannot be used for this purpose. A light-duty detergent is recommended, but any residue should always be washed out thoroughly.

A special process ensures that the sensors have good long-term stability. Regeneration is not necessary, but is also not harmful.

» CLEANING PROCESS

1. **Disconnect device from voltage!**
2. Dip the sensor tube into a receptacle containing clean water (68 °F) and, with a gentle rotating motion, disperse the dirt deposits. If the dirt contains grease deposits, it is recommended that a mild detergent be added to the water. Cleaning should be carried out for no longer than some seconds.
Do not brush or treat with any other cleaning equipment!
Only the sensor tube can be dipped - not the enclosure (the sensor tube is open to the enclosure – 0,8 mm hole).
3. As detergents contain chemical substances, rinse carefully after cleaning.
Cleaning residues will decline the measured results.
4. Air drying. Where a measuring element is moistened with water, the device indicates 100% relative humidity. If necessary, it is possible to carry out sensitive recalibration at the adjusting spindle at the end of the sensor. This should only be done where there are large deviations. Slight movement of the adjusting spindle of a wet element causes the measured value in the dry area to be badly out. Here, there is an intensifying effect of the linearization (factor 6).

The measuring element must not be dried using warm or hot air (hair dryer). Indications of 98..100% relative humidity at the wet element are adequate. The accuracy in the dry area must be determined under normal climatic conditions.

» DIMENSIONS (MM)

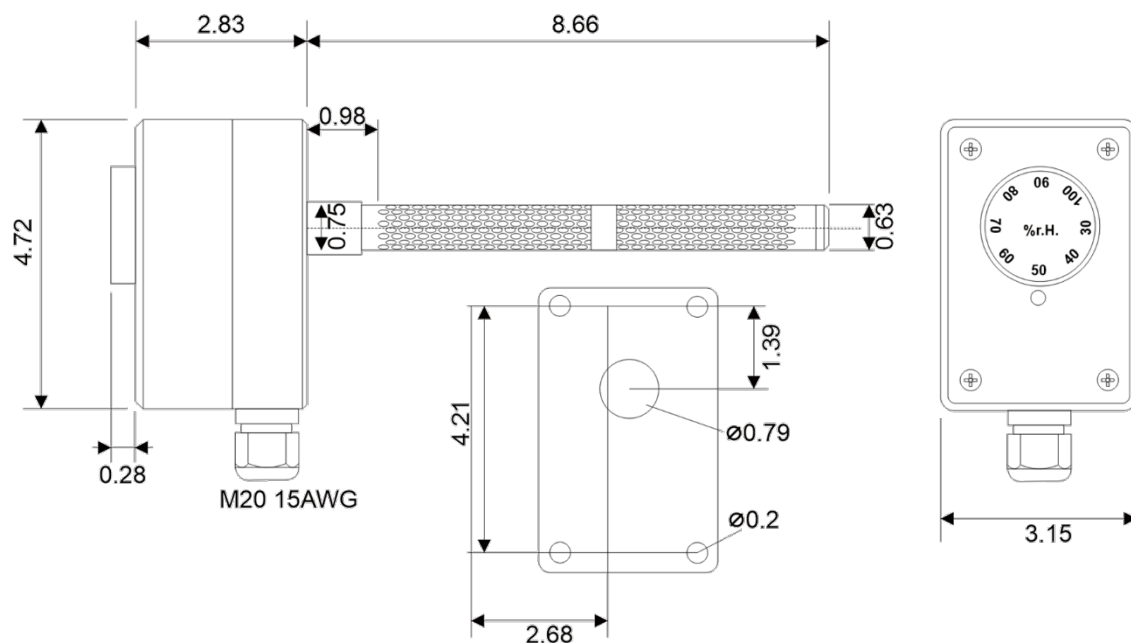

» ACCESSORIES (OPTIONAL)

PTFE-Filter (for air speeds > 15m/s)
 Sensor protection (wire mesh) for fan speeds 26..50 ft./s
 Wall mounting
 Mounting flange MF19-(TPO)

Item No. 429054
 Item No. 231169
 Item No. 429030
 Item No. 527705