



## Installation use and maintenance



(Original instructions)



# SR ONE M

## Safety Muting Module

SAFETY MUTING MODULE

**SR ONE M**

**INSTALLATION USE AND MAINTENANCE**

**TABLE OF CONTENTS**

**OVERVIEW ..... 3**

**OPERATING MODES DESCRIPTION ..... 3**

    AUTOMATIC MODE..... 4

    MANUAL MODE..... 5

    CONNECTION OF EXTERNAL CONTACTORS K1 AND K2 ..... 6

    CONNECTION EXAMPLE..... 8

**MUTING FUNCTION ..... 9**

    MUTING SEQUENCE..... 9

    MUTING OVERRIDE FUNCTION ..... 11

        OVERRIDE WITH HOLD-TO-RUN ACTION CONTROL..... 11

        OVERRIDE WITH PULSE CONTROL ..... 12

**ELECTRICAL CONNECTIONS ..... 13**

    INSTRUCTIONS CONCERNING CONNECTION CABLES..... 13

    PINOUT ..... 14

        SELECTION OF THE MUTING TIMEOUT ..... 14

        SELECTION OF THE OVERRIDE..... 14

**CHECKLIST AFTER INSTALLATION ..... 15**

**INPUT AND OUTPUT ..... 16**

    THE RESTART COMMAND INPUT ..... 16

    SYSTEM STATUS OUTPUT..... 16

    THE MUTING ENABLE INPUT..... 16

    MUTING STATUS AND LIGHT..... 17

    CHARACTERISTICS OF THE OUTPUT CIRCUIT..... 17

    USE OF K1 AND K2 AUXILIARY CONTACT ELEMENTS..... 17

    K1 K2 FEEDBACK INPUT (EDM) ..... 18

**STATUS INDICATORS / FAULT DIAGNOSIS ..... 19**

    MUTING OPERATION..... 19

    NORMAL OPERATION ..... 19

    FAULT DIAGNOSIS..... 20

**TECHNICAL DATA ..... 21**

    DIMENSIONS..... 22

**INDICATIONS AND INFORMATION FOR ENVIRONMENTAL PROTECTION ..... 23**

**WARRANTY..... 24**

**EC DECLARATION OF CONFORMITY ..... 25**

**UKCA DECLARATION OF CONFORMITY ..... 26**

## OVERVIEW

This symbol indicates an important personal safety warning. Failure to comply with the warning may result in very high risk for exposed personnel.

This symbol indicates an important warning.

The SR ONE M Safety Relay module, connected to an EN 61496 – 1/2 certified type 4 safety light curtain and equipped with two auto-controlled PNP type solid-state outputs, is a type 4 ESPE (Electro-sensitive Protective Equipment).

The other characteristics indicated above remaining constant, if the light curtain is type 2, the entire ESPE will be type 2.

### The SR ONE M main features are the following:

- Inputs for the connection of one safety light curtain with fail safe outputs
- Restart manual or automatic selectable
- 2 N.O. outputs with guided contact safety relays
- 1 system monitor PNP output
- 1 external contactors feedback input
- Muting function with two sensors logic
- 1 Muting function enable input
- 1 muting lamp output
- Muting Override function integrated
- Selectable muting timeout

### The safety module also guarantees that:

- The output lines are open if the connected device is in OFF status;
- The output lines are enabled only with correct response times;
- In manual mode, maintenance of the RESTART contact closed is not interpreted as AUTO mode.

For safe use of the SR ONE M module, it is essential to read and understand the contents of this handbook.

Failure to comply with the prescriptions indicated in this handbook may result in very high risks for the operating personnel of the machine protected.

## OPERATING MODES DESCRIPTION

### OPERATING MODES SELECTION

TERMINAL 6	TERMINAL 15	OPERATION
0 Vdc	+24 Vdc	Automatic
+24 Vdc	+24 Vdc through a N.O. contact	Manual
0 Vdc	0 Vdc	Non-permissible conditions
+24 Vdc	+24 Vdc	

Table 1

**AUTOMATIC MODE**

In this operating mode, the outputs of the safety module follow the status of the light curtain:

- with the protected area free (outputs of the light curtain active), the relay outputs of the unit are active.
- with the protected area occupied (outputs of the light curtain de-activated), the relay outputs of the safety module are de-activated.

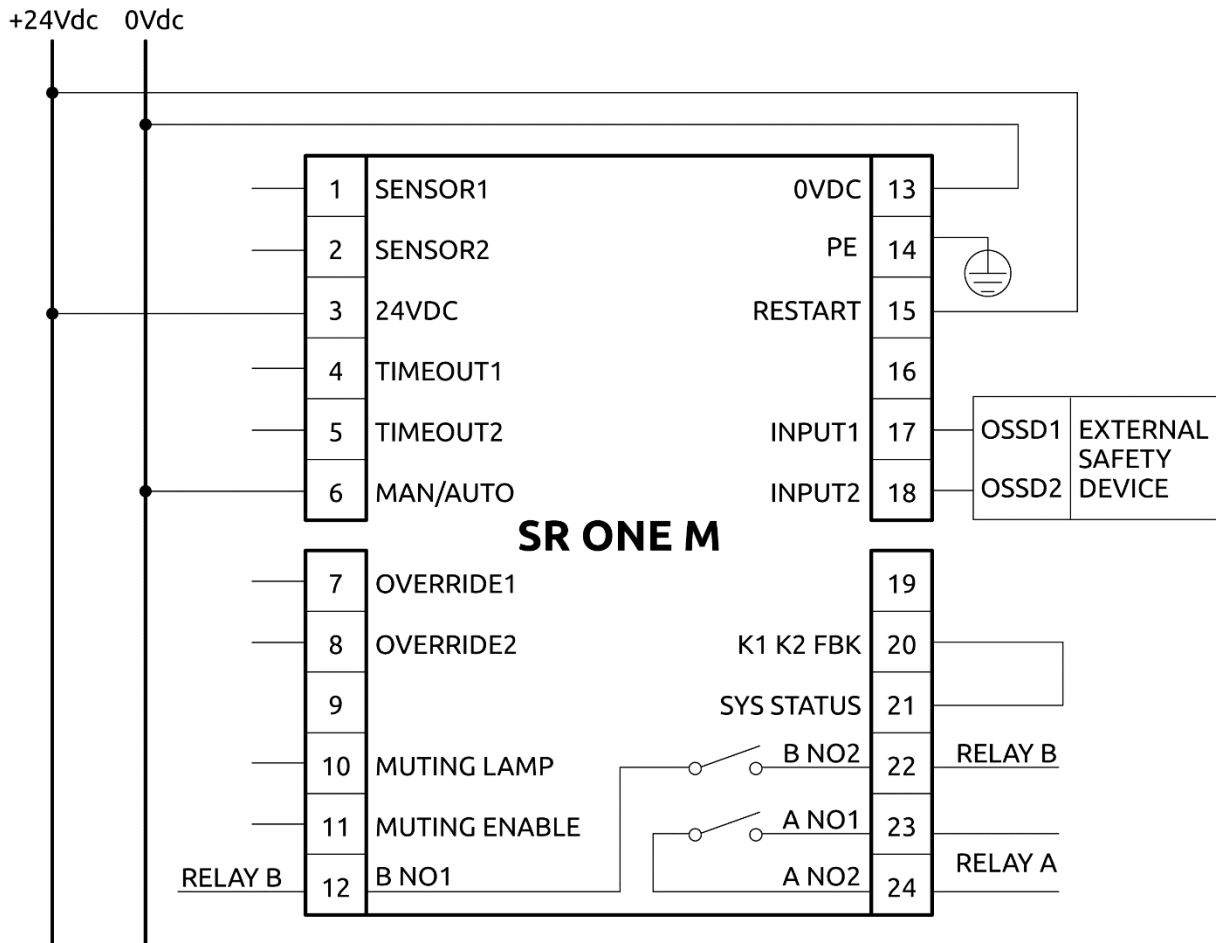

Figure 1 – Automatic operation without K1 K2 relays

- ⚠ Use in manual mode (start/restart interlock activated) is mandatory in case the safety device controls an access protecting a danger zone and once a person has passed through the opening, he/she may remain in the danger zone without being detected (use as trip device according to EN 61496). Failure to comply with this rule may result in very serious risks for the persons exposed.
- ⚠ When the K1-1 and K2-1 N.C. control contacts are not used (or no control is provided) it is mandatory to connect the terminal 20 (K1 K2 FBK) to terminal 21 (SYS STATUS).
- ⚠ Check correct functioning of the entire safety system (safety module + light curtain) following each re-installation. In particular, if the original operating mode was Manual, check that the unit has been reconfigured in this mode.

**MANUAL MODE**

In this operating mode, the outputs of the safety relay are activated only if the protected area is free and after sending the RESTART signal to the module using a push-button or by means of a specific command on the RESTART input (terminal 15).

- ➔ Once the protected area has been occupied, the outputs relays are de-activated.
- ➔ The sequence described on "THE RESTART COMMAND INPUT" section must be repeated to re-activate the outputs relay.

**⚠** Check correct functioning of the entire safety system (safety module + light curtain) following each re-installation. In particular, if the original operating mode was Manual, check that the module has been reconfigured in this mode.

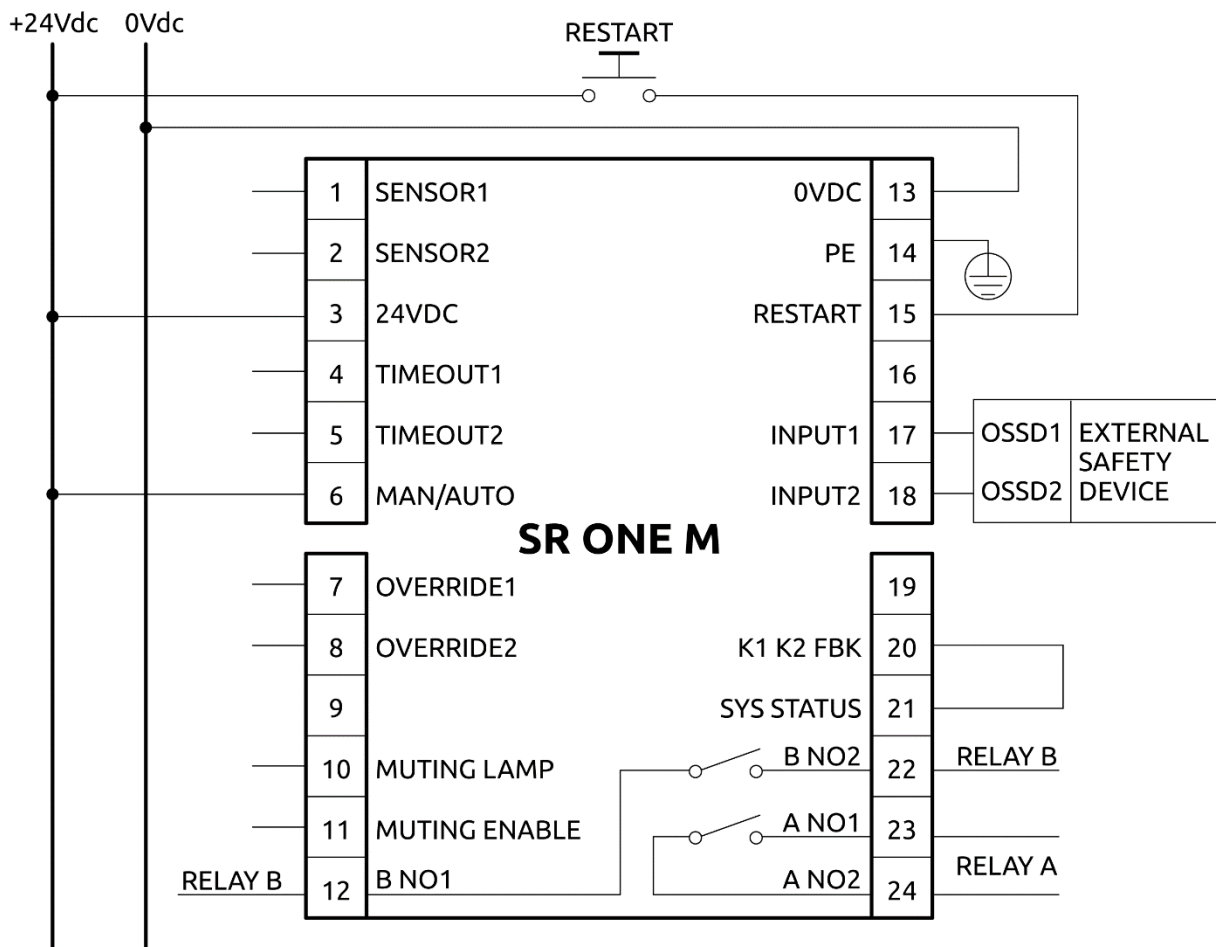

Figure 2 – Manual operation without K1 K2 relays

**⚠** When the K1-1 and K2-1 N.C. control contacts are not used (or no control is provided) it is mandatory to connect the terminal 20 (K1 K2 FBK) to terminal 21 (SYS STATUS).

**CONNECTION OF EXTERNAL CONTACTORS K1 AND K2**

Control of external contactors K1 K2 can be activated in both operating modes. If this control must be used, the series of normally closed contacts of the external contactors must be connected to terminal 20 of the safety relay (figures 3 and 4).

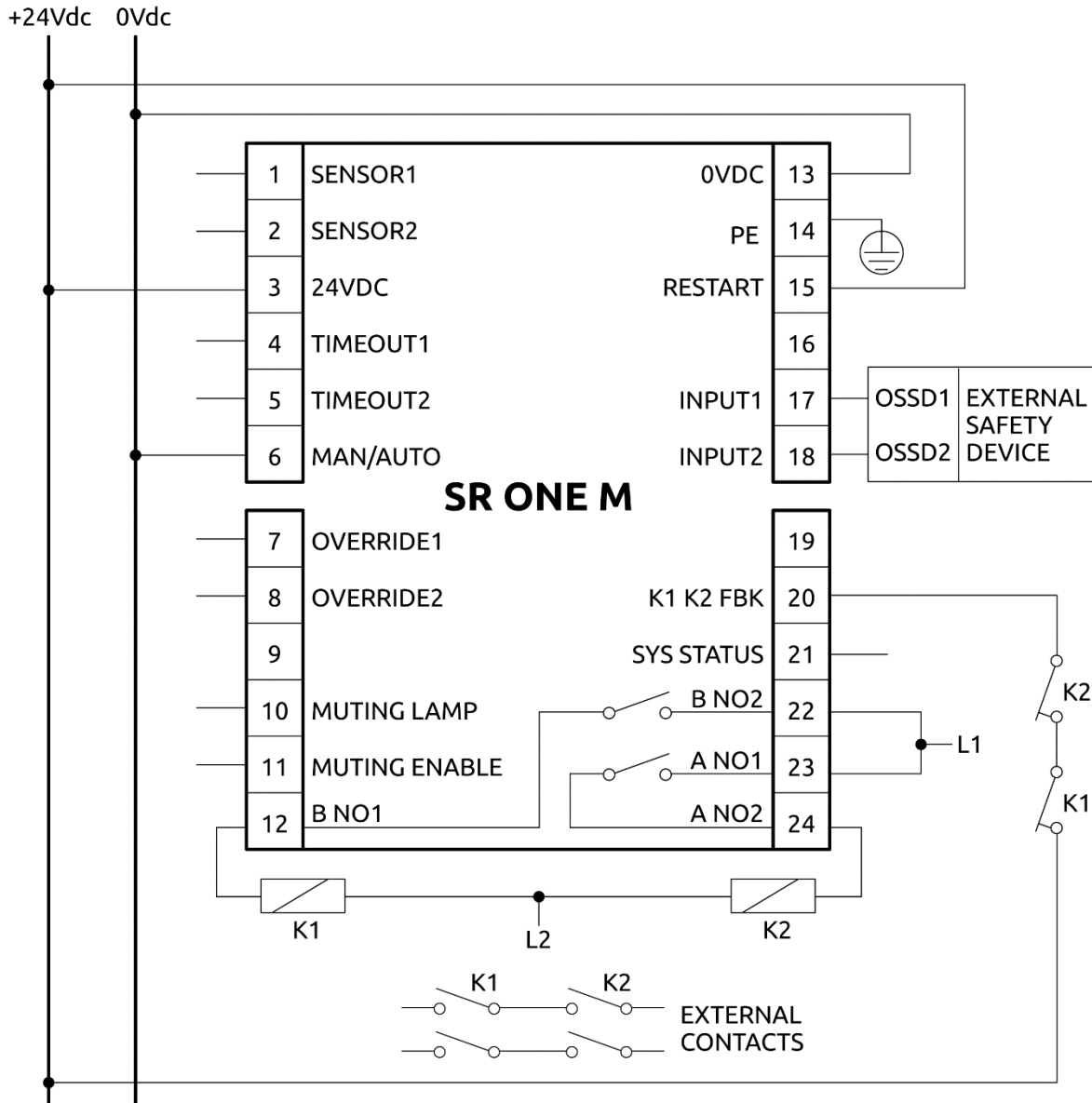

Figure 3 - Automatic operation with K1 K2 relays

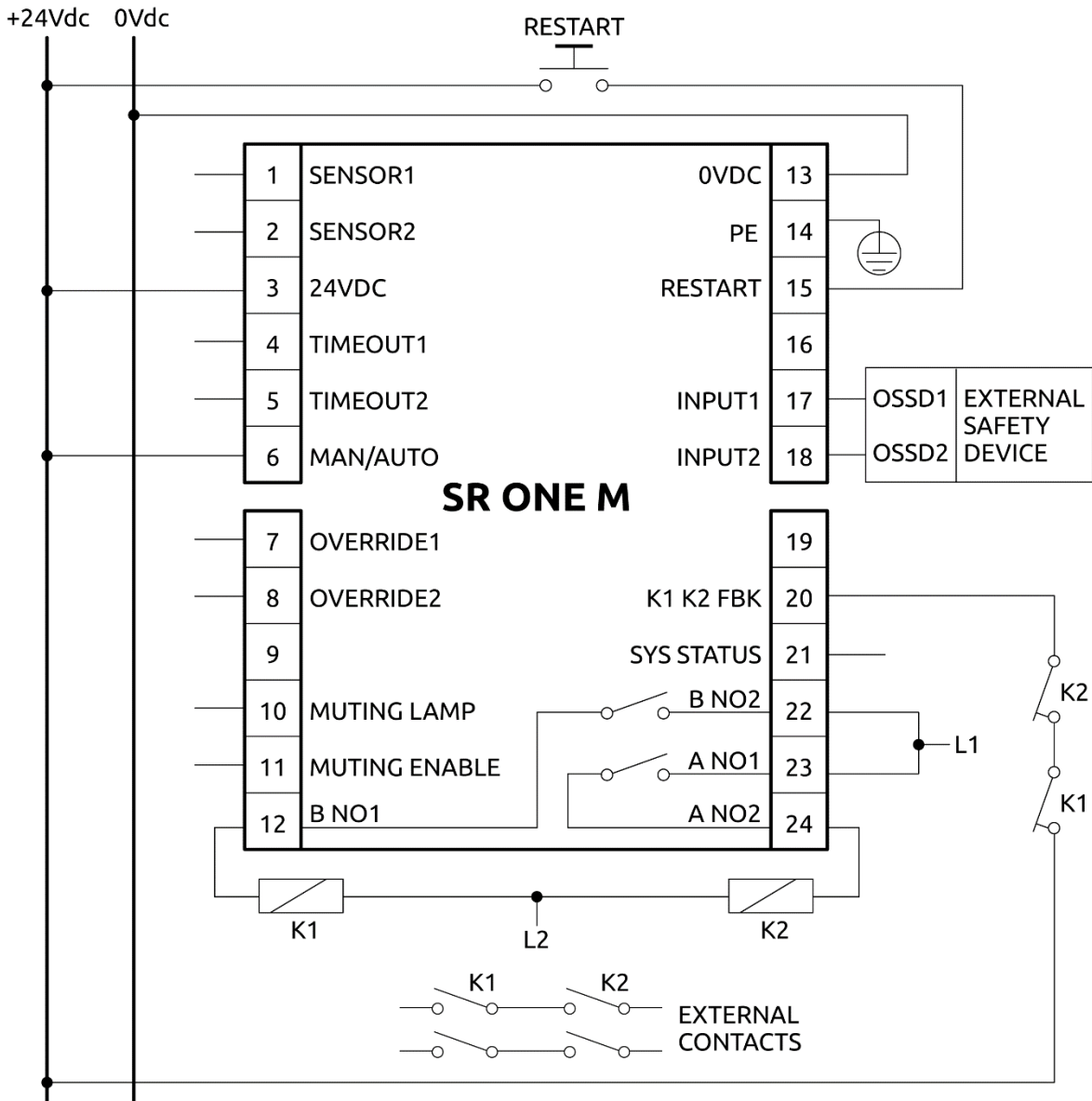

Figure 4 - Manual operation with K1 K2 relays

**CONNECTION EXAMPLE**

**Connection of SR ONE M with an EOS4A light curtain**  
**Manual mode, working range high, K1K2 external contactors and timeout muting = 30s**

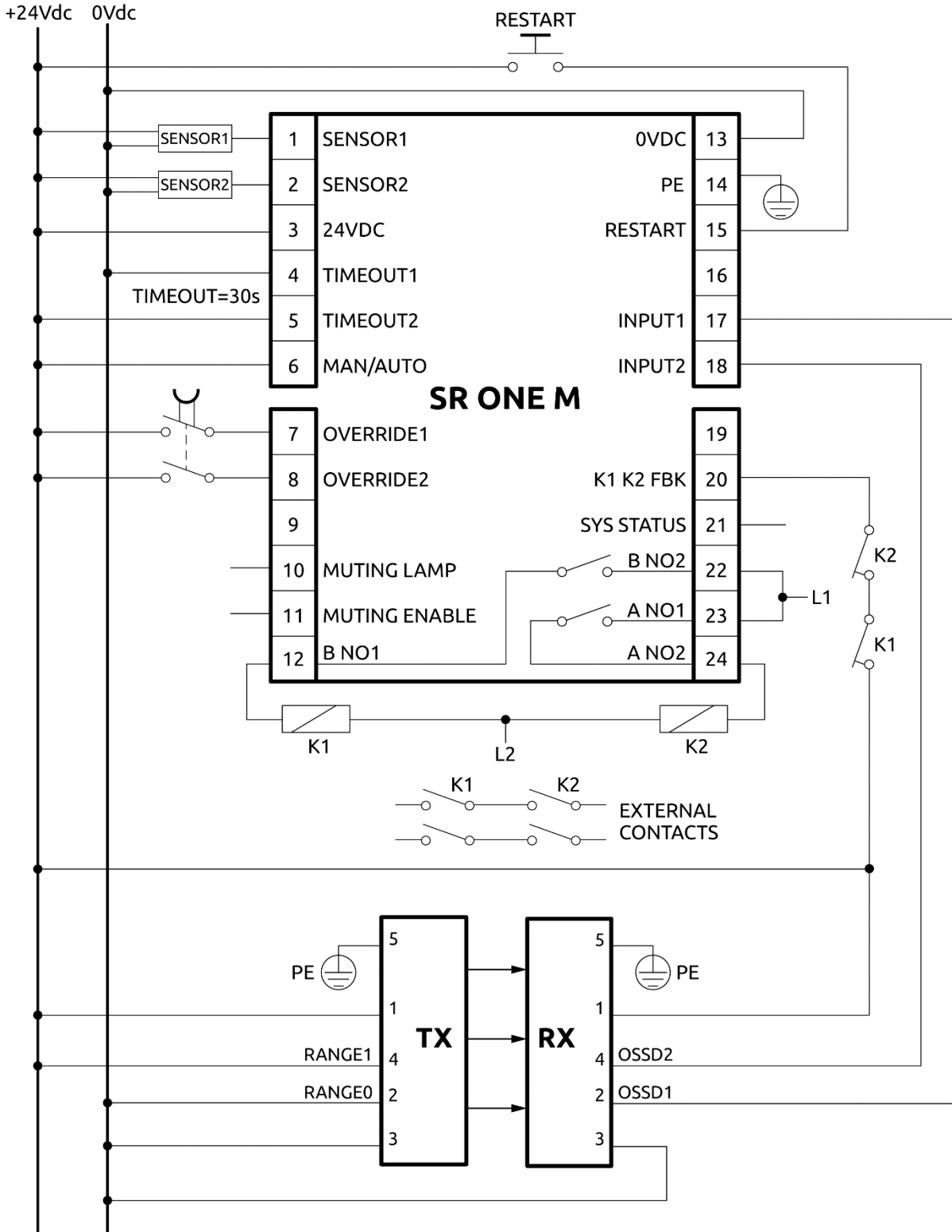

Figure 5



**MUTING FUNCTION**

**⚠** The Muting function is a temporary suspension of the safety light curtain’s protective function. Carefully check your risk analysis to assess whether the Muting function is compatible with your application and what additional measures must be taken.

The Muting function generates a temporary, automatic interruption of the protective action of the light curtain to permit normal transit of material through the guarded opening.

The Muting function is activated when the system detects the object that interrupts the opening protected. In other words, when the system recognizes the material and distinguishes between this and any operator (in a potentially dangerous situation), it is enabled to bypass the light curtain temporarily, allowing the material to pass through the opening (Figure 6).

**The Muting sensors** form the sensing system that decides whether the Muting function is to be activated (or not). Control of the dangerous opening can be de-activated only by a correct sequence of interruption of the beams of the Muting sensors.

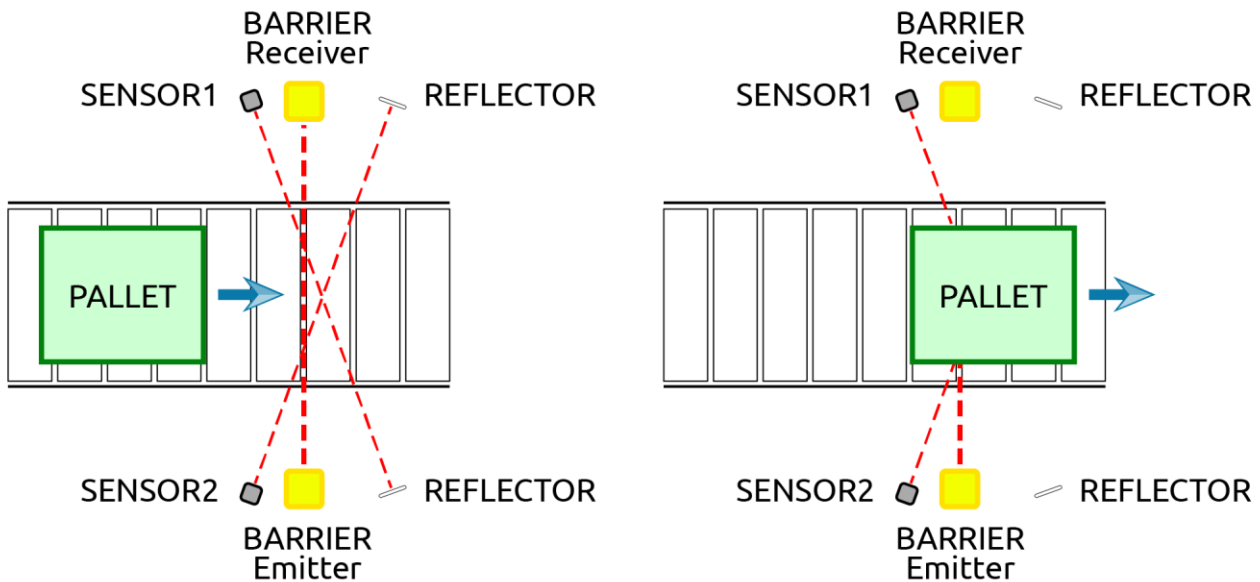

Figure 6 - Muting on palletizing system application example

**MUTING SEQUENCE**

The timing diagrams in Figure 7 and Figure 8 show the correct signal sequence. The muting function is initiated by the contemporary occurrence of two events:

- When the two beams of the muting sensors are activated within a time limit of 4 sec.
- When the MUTING ENABLE signal (terminal 11) is high (+24VDC)

The muting function is terminated by one of the following events:

- As soon as one of the muting sensors is no longer activated whichever occurs first.
- When the muting time-out limit is expired; in this case the module outputs are brought to the off-state. The muting time-out limit can be selected at 30sec or ∞.

- The MUTING ENABLE command will only enable the muting function and should be generated at the appropriate time by the machine control system (e.g., When the muting function is needed); it has no effect on the deactivation of the muting function. If not used, fix the terminal 11 at +24VDC.
- **Muting function is a temporary automatic suspension of the safety function.** This means that a time limit is always mandatory. If a time out limit of 30 sec is a too short time for a particular machine cycle, the configuration without time monitoring ( $t = \infty$ ) can be selected. In this case alternative solutions or additional measures shall be implemented **to detect the condition of a muting function permanently active caused by accumulation of faults** or by the muting sensors activated all the time. For example, for the application of guarding the openings of a conveyor system (palletizers) by monitoring appropriate signals generated by the transport system to determinate when a pallet is in the detection zone.

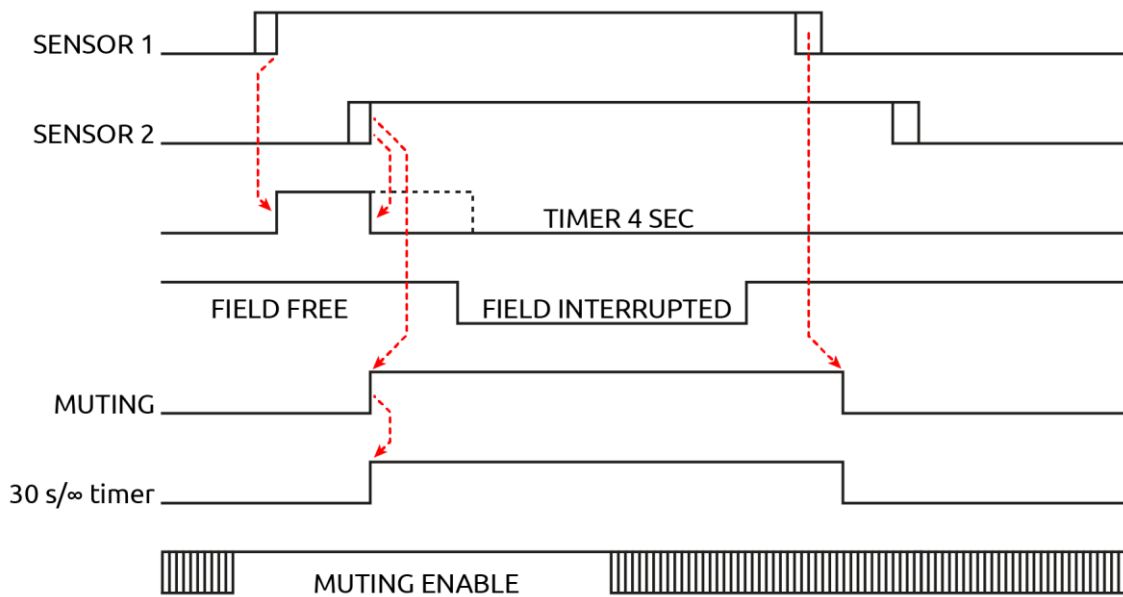

Figure 7 - Muting cycle

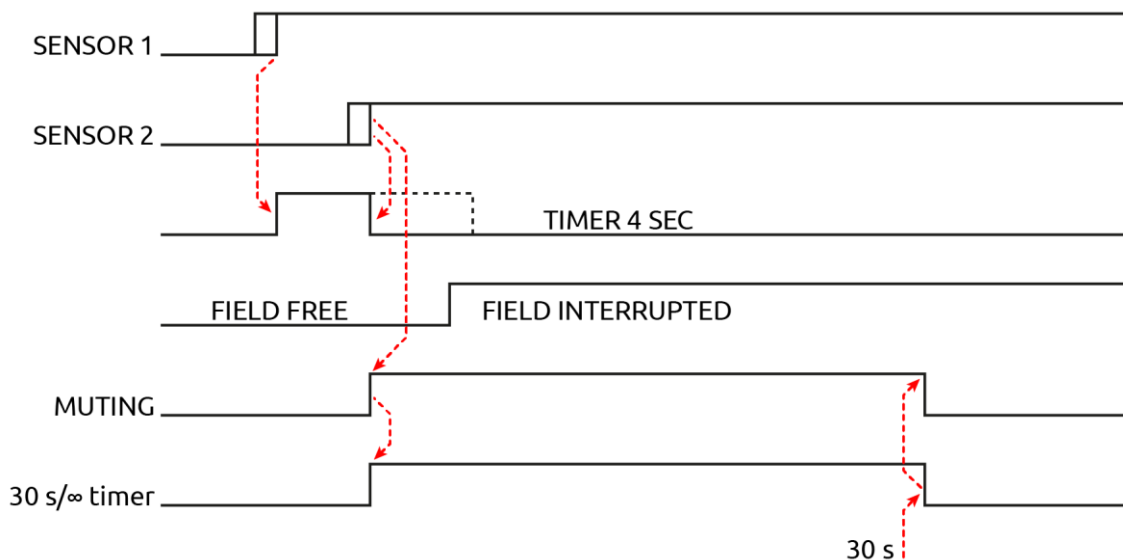





Figure 8 - Muting cycle closed by a timeout

## MUTING OVERRIDE FUNCTION

The **OVERRIDE** function must be used when the machine stops due to incorrect Muting activation sequences with the material obstructing the guarded opening.

In this situation, the module outputs are not active as the light curtain and/or at least one Muting sensor is occupied. In this condition the **OVERRIDE** request led blinks (ref. "Status Indicators").

-  This function activates the module outputs making it possible to remove the material that is obstructing the protected field.
-  Throughout the entire phase during which the **OVERRIDE** function is active, the **OVERRIDE/MUTING** light blinks. Check efficiency of this light periodically (during the Muting or Override phases).
-  **Warning!!** The Override with pulse command automatically activates the outputs of the light curtain until both the light curtain and the muting sensors are free of obstacles again. During this period, the light curtain is unable to protect access to the guarded opening. Therefore, all operations must be carried out under the strict supervision of expert personnel.
-  During the installation of the module be sure to avoid short circuits between the contacts 7 and 8.

The operator will use the Override mode previously selected.

1. Override with **hold-to-run action** control.
2. Override with **pulse** control.

### OVERRIDE WITH HOLD-TO-RUN ACTION CONTROL

This function is activated driving terminals 7 and 8 of the control unit to +24VDC at the same time (maximum delay = 400ms) using for example a 2-way key selector with spring return;

PIN 7	PIN 8	CONDITION
0	0	Normal operation
24VDC	24VDC	<b>OVERRIDE</b> request

The maximum override duration is 15 minutes; it can be stopped for two different causes.

- ➔ **When the selector is released or if the 15 minutes has been elapsed, override ends**, deactivating the module outputs, turning off the muting lamp and showing normal condition on the display. A new override condition can be started, releasing, and rearming the selector.
- ➔ **Once the opening has been cleared and the sensors are free again**, override ends, and **GUARD** condition (control unit in normal operation) is activated without necessity of further commands.

---

**OVERRIDE WITH PULSE CONTROL**

---

This function is activated inverting (**maximum delay = 400ms**) the condition of pin 7 and 8 of the receiver using for example a push button (switch). During the override, the 7 and 8 are not controlled.

PIN 7	PIN 8	CONDITION
0	24VDC	Normal operation
24VDC	0	OVERRIDE request

- ➔ The override condition can last a maximum of **15 minutes** (repeatable).
- ➔ The function can only be re-started by pressing the pushbutton again (**subject to the following conditions**):
  1. Maximum total OVERRIDE time (after n consecutive requests) = **60 min**
  2. Maximum number of consecutive requests for OVERRIDE = **30**.
- ➔ The override condition ends when the light curtain and sensors are cleared (entrance clear) and the GUARD condition is re-enabled (light curtain fully operational) without sending any further commands.
- ➔ The timer (point 1) and counter (point 2) are reset when one of the following conditions occurs:
  - A correct muting sequence.
  - A system reset (switched off and then turned on).

## ELECTRICAL CONNECTIONS

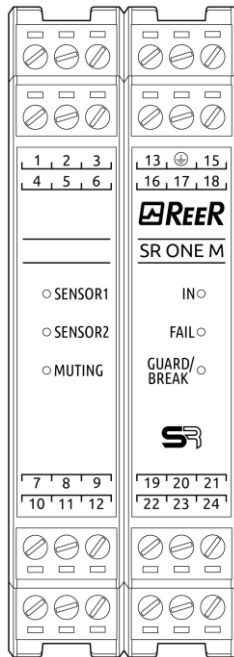

Figure 9

SR ONE M is provided with terminal blocks for the electrical connections.  
The unit provides 24 terminals.

→ Terminal tightening torque: 5...7lb-in (0,6...0,7 Nm).

- Install the SR ONE M safety relay in an environment with a protection rating of at least IP54.
- If more modules SR ONE M must be installed in the same board panel, to avoid overheating, maintain between them one minimal distance of 2cm.
- Connect the safety relay module when it is not powered.
- The supply voltage must be  $24 \pm 20\%$  VDC; PELV (in compliance with the standard EN 60204-1 (Chapter 6.4)).
- During the installation of the SR ONE M safety relay be sure to avoid short circuits between the contacts 17 and 18.
- Do not use the SR ONE M to supply external devices.
- The same ground connection (0VDC) must be used for all system components.

## INSTRUCTIONS CONCERNING CONNECTION CABLES.

- Wire size range: AWG 12...30, (solid/stranded) (UL).
- Use 60/75°C copper (Cu) conductor only.
- We recommend the use of separate power supplies for the safety controller and for other electrical power equipment (electric motors, inverters, frequency converters) or other sources of disturbance.
- Cables used for connections longer than 50m must have a cross-section of at least  $1\text{mm}^2$  (AWG16).

**PINOUT**

TERMINAL NUMBER	SIGNAL NAME	TYPE OF SIGNAL	DESCRIPTION
1	SENSOR1	Input	Muting sensor 1
2	SENSOR2	Input	Muting sensor 2
3	24VDC		Power supply 24VDC
4	TIMEOUT1	Input	Timeout selection 1 *
5	TIMEOUT2	Input	Timeout selection 2 *
6	MAN/AUTO	Input	Manual/Automatic Configuration
7	OVERRIDE1	Input	Override selection 1 **
8	OVERRIDE2	Input	Override selection 2 **
9	-	-	-
10	MUTING LAMP	Output	Muting lamp connection
11	MUTING ENABLE	Input	External Muting Enabling
12	B NO1	Output	Safety relay B, contact 1 (N.O.)
13	0VDC		Power supply 0VDC
14	PE		Ground connection
15	RESTART	Input	Restart command
16	-	-	-
17	INPUT1	Input	Safety Input 1
18	INPUT2	Input	Safety Input 2
19	-	-	-
20	K1 K2 FBK	Input	Feedback external contactors K1 K2
21	SYS STATUS	Output	Output Status
22	B NO2	Output	Safety relay B, contact 2 (N.O.)
23	A NO1	Output	Safety relay A, contact 1 (N.O.)
24	A NO2	Output	Safety relay A, contact 2 (N.O.)

Table 2

\* REFER TO THE *Table 3* FOR THE SELECTION OF THE MUTING TIMEOUT

\*\* REFER TO THE *Table 4* FOR THE SELECTION OF THE OVERRIDE

➔ Read carefully the "Muting sequence" section to select the right timeout

**SELECTION OF THE MUTING TIMEOUT**

TERMINAL 4	TERMINAL 5	DURATA TIMEOUT
0 Vdc	+24 Vdc	30s
+24 Vdc	0 Vdc	Infinite
0 Vdc	0 Vdc	Conditions not allowed
+24 Vdc	+24 Vdc	

Table 3

**SELECTION OF THE OVERRIDE**

TERMINAL 7	TERMINAL 8	TIPO DI OVERRIDE
0 Vdc	0 Vdc	Hold-to-run
0 Vdc	+24 Vdc	Pulse
+24 Vdc	0 Vdc	Conditions not allowed
+24 Vdc	+24 Vdc	

Table 4

## CHECKLIST AFTER INSTALLATION

The SR ONE M Safety Relay Module can detect in real time the faults.

Nevertheless, to guarantee the system perfect operation perform the following checks at start up and before each work shift:

OPERATION / CONTROL	COMPLETE
1. <i>Verify that all the cables are correctly inserted and the terminal blocks well screwed.</i>	<input type="checkbox"/>
2. <i>Verify the correct fixing of SR ONE M to the Omega rail.</i>	<input type="checkbox"/>
3. <i>Verify that muting sensors are correctly positioned and mechanically protected.</i>	<input type="checkbox"/>
4. <i>Verify the correct positioning of the light curtain connected to SR ONE M.</i>	<input type="checkbox"/>
5. <i>Verify that all the LEDs (indicators) light on correctly.</i>	<input type="checkbox"/>
6. <i>Verify that all the external indicators (lamps) work properly.</i>	<input type="checkbox"/>
7. <i>Operate a complete System Test.</i>	<input type="checkbox"/>

Table 5

 ReeR recommend operating a TEST before each work shift.

## INPUT AND OUTPUT

### THE RESTART COMMAND INPUT

- ➔ The RESTART command must be sent to SR ONE M connecting terminal 15 to the 24VDC, respecting the behaviour of the timing beside.
- ➔ The contact used for the RESTART command must be able to switch a voltage of 24VDC and a current of 10mA (guaranteeing a closing time:  $t_1: 5s > t_1 > 100ms$ ).
- ➔ The whole SYSTEM RESET TIME is obtained adding the reset time of any external contactors K1 K2 to the reset time of SR ONE M.

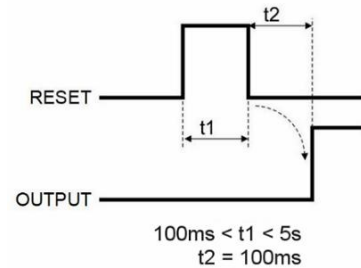

- This data is particularly important in the case of automatic management of the RESTART command sending, for example using a PLC.
- In the case of manual activation, a normally open external button can be used, temporary closing of which generates the RESTART command.

- ⚠ The RESTART command must be installed outside the dangerous area in a position where the dangerous area and the entire work area concerned are clearly visible.
- ⚠ It must not be possible to reach the control from inside the dangerous area.

### SYSTEM STATUS OUTPUT

The **SYSTEM STATUS** output (terminal 21) reports exactly the output safety relays status:

- When the output relays are opened, the SYSTEM STATUS reports 0VDC.
- When the output relays are closed, the SYSTEM STATUS reports +24VDC.

### THE MUTING ENABLE INPUT

The **MUTING ENABLE** command (terminal 11) enables the muting function and should be generated at the appropriate time by the machine control system (when the muting function is needed).

When this input is raised to +24VDC the muting function is enabled.

- ⚠ This input has no effect on the deactivation of the muting function. If not used, fix the terminal 11 at +24VDC.



## MUTING STATUS AND LIGHT

Muting status must be highlighted to the outside using an indicator light close to the guarded opening.

- SR ONE M is equipped with a “**MUTING LAMP**” output (terminal 10) to which the indicator light can be connected and is able to monitor its correct operation and that it is present.
- When a **short circuit** is detected on the muting lamp:
  - 1) terminal 10 short circuited to 24VDC when the muting function is OFF
  - 2) terminal 10 short circuited to 0VDC when the muting function is ON
 SR ONE M will switch to stop status indicating a FAIL condition.
- When an **overloading/overcurrent** is detected on the muting lamp: SR ONE M will switch to stop status indicating a FAIL condition.

## CHARACTERISTICS OF THE OUTPUT CIRCUIT

For the output circuit, the safety relay module uses two guided contact safety relays.

These relays are rated by the manufacturer for voltage and current values above those indicated in the technical data; however, to assure correct insulation and to avoid damage or premature aging, protect each output line with an appropriate fuse (depending on the load). Check that load characteristics comply with the indications given in the table below.

<b>Minimum switching voltage</b>	18 VDC
<b>Minimum switching current</b>	20 mA
<b>Maximum switching voltage</b>	250 VAC
<b>Maximum switching current</b>	6A(AC) / 6A(DC)

## USE OF K1 AND K2 AUXILIARY CONTACT ELEMENTS

For loads with higher voltage and current characteristics than those indicated in the table above, use of auxiliary external relays or contactors suitable for the load to be controlled is recommended.

- The K1 and K2 auxiliary contactors or relays must be of the guided contact safety type.
- Referring to the table below, pay particular attention to the configuration of the control contacts on terminal 20 and that of the contacts of use. (Refer to the “*K1 K2 FEEDBACK input (EDM)*” section).

	<b>Relay K1</b>	<b>Relay K2</b>
<b>Control contacts</b>	K1-1 normally closed	K2-1 normally closed
<b>Use contacts</b>	K1-2 normally open	K2-2 normally open

- Control contacts K1-1 and K2-1 (terminal 20) must be able to switch a current of 20mA and a voltage of 24VDC.
- To increase the electrical life of internal relays A and B, it is advisable to use anti-disturbance devices which must be connected across the coils of K1 and K2.

---

## **K1 K2 FEEDBACK INPUT (EDM)**

---

Using the K1 and K2 auxiliary safety contactors with guided contact safety type, it is necessary to connect the +24VDC to the **K1 K2 FBK** through the series of the K1-1 and K2-1 N.C. control contacts.

→ The control of the correct switching of K1 and K2 is performed with a delay of 300ms.

⚡ If the application requires it, the response time of the external contactors must be verified by an additional device.

⚡ When the K1-1 and K2-1 N.C. control contacts are not used (or no control is provided) it is mandatory to connect the terminal 20 (K1 K2 FBK) to terminal 21 (SYS STATUS).

## STATUS INDICATORS / FAULT DIAGNOSIS

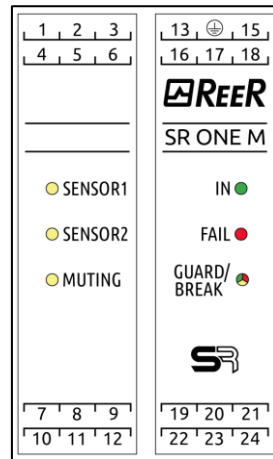

### MUTING OPERATION

LED			MEANING
SENSOR1 (Yellow)	SENSOR2 (Yellow)	MUTING (Yellow)	
ON	ON	ON	Power up test
OFF	OFF	OFF	Both the sensors are free
ON	OFF	OFF	Sensor 1 interrupted
OFF	ON	OFF	Sensor 2 interrupted
ON	ON	ON	Muting active
Shows the SENSOR1 status	Shows the SENSOR2 status	Blinking	Override request
		Blinking with FAIL RED ON	Muting fail *

\* REFER TO THE "FAULT DIAGNOSIS" SECTION TO HAVE A DETAILED EXPLANATION OF THE POSSIBLE FAULT.

Table 6

### NORMAL OPERATION

LED			MEANING
IN (Green)	FAIL (Red)	GUARD/BREAK (Red/Yellow/Green)	
ON	ON	RED	Power up test
OFF	OFF	RED	Light curtain interrupted - Output relays opened
ON	OFF	YELLOW	Light curtain free - Output relays opened
ON	OFF	GREEN	Light curtain free - Output relays closed
	RED	RED Blinking	Fault detected *

\* REFER TO THE "FAULT DIAGNOSIS" SECTION TO HAVE A DETAILED EXPLANATION OF THE POSSIBLE FAULT.

Table 7

**FAULT DIAGNOSIS**

**MUTING MODULE FAULT INDICATORS**

➔ The following status signals are present with the base module permanently light on.

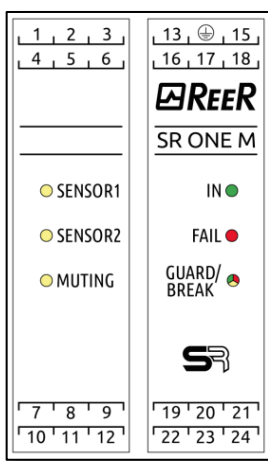

LED			MEANING
SENSOR1 YELLOW	SENSOR2 YELLOW	MUTING YELLOW	
OFF	OFF	(2 pulses)	▪ Bad connection of the muting lamp, lamp not present, in overload or in short circuit
OFF	OFF	(3 pulses)	▪ Muting timeout wrong configuration
OFF	OFF	(4 pulses)	▪ Wrong override configuration at the power up
Shows the SENSOR1 status	Shows the SENSOR2 status	(5 pulses)	▪ Instable Muting Sensor
Blinking	Blinking	Blinking	▪ Override with pulse command expired

Table 8

**BASE MODULE FAULT INDICATORS**

IN GREEN	FAIL RED	LED		MEANING
		GUARD/BREAK RED/GREEN (pulses red LED)		
OFF	ON	(2 pulses)		▪ Internal fault
OFF	ON	(3 pulses)		▪ Internal relays fault
OFF	ON	(4 pulses)		▪ K1 K2 external relays fault
OFF	ON	(5 pulses)		▪ User configuration failure ▪ INPUT1/2 BARR consistency check failed (<20ms) Check connected light curtain outputs
OFF	ON	(6 pulses)		▪ User configuration changed without system restart: ▪ Switch off and restart the module to solve the problem. ▪ At the switch on verify the new user configuration.
OFF	ON	(7 pulses)		▪ Possible overload or ▪ SYSTEM STATUS connection error

Table 9

**⚠** If it is not possible to clearly identify the malfunction and to remedy it, stop the machine and contact the Reer's After Sales Department.

**TECHNICAL DATA**

SAFETY DATA	VALUE	STANDARD
Safety level	Type 4	EN 61496-1: 2020
	SILCL 3	EN 62061:2005 / A2:2015
	Cat.4	EN ISO 13849-1: 2015
Device lifetime	20 years	EN ISO 13849-1: 2015
Certifications	cULus, TÜV	

Load	Number of Commutations	PFHd *	DCavg #	MTTFd # (years)	PL #	CCF #
2A@230Vac	1 every 30s	1,76E-07	98,97%	24,22	d	80%
	1 every min	9,19E-08	98,95%	43,84	e	80%
	1 every hour	9,48E-09	98,73%	215,69	e	80%
	1 every day	8,17E-09	98,72%	230,02	e	80%
0,5A@24VDC	1 every 30s	3,44E-07	98,98%	12,78	d	80%
	1 every min	1,76E-07	98,97%	24,22	d	80%
	1 every hour	1,09E-08	98,75%	202,26	e	80%
	1 every day	8,26E-09	98,72%	229,00	e	80%

\* EN 61508:2010, EN 62061:2005/A2:2015; # EN ISO 13849-1:2015

ELECTRICAL PARAMETERS	VALUE
Power supply	24 ± 20% VDC; PELV
Rated impulse between PELV and relay contacts	4 kV
Power requirement	3W max
Protection	Overload protected STATUS output
INPUT DATA	VALUE
Number of connectable light curtains	1 (with 2 PNP OSSD output)
Inputs number/data (type 3)	10 / according to standard EN61131-2, type 3
Input current	Typical 4.3mA
Input voltage	0VDC...30VDC
Inputs number/data (type 2)	1 / according to standard EN61131-2, type 2
Input current	Typical 10mA
Number of EDM input	1 N.C. contact
EDM Response time	300ms
OUTPUT DATA	VALUE
Number of safety output	2 N.O. contacts
Type	Relays with forced guided contacts
Max switching voltage	250VAC, 125 VDC, Overvoltage Category II
Max switching current	6A (AC), 6A (DC)
Max switching power	1500VA, 180W (85W if load voltage >30VDC)
Max Response time	20ms
Mechanical service life	10 x 10E6
Electrical service life AC1 at 360 switchings/h	> 10E5
System Status Output number/ value	1 / 100mA@24VDC
External Muting Lamp Output	24VDC with short circuit control
MUTING DATA	VALUE
Muting Enable input	1 / according to standard EN61131-2, type 3
End of Muting	By timeout or by a correct muting cycle
Muting Timeout	30s or infinite
Override control	Hold-to-Run / Pulse (maximum delay = 400ms)
Max Override timeout / Max number Override	15 minutes (repeatable) or 60min / 30 replication

CONNECTIONS / OPERATION	VALUE
Operating modes	Automatic or Manual, selectable from terminal block
Connections	24 Terminal block with protection against reversal of polarity
Status indicators	LED: Input - Output Status - Fail - Sensor - Muting
Operating modes	Manual or Automatic, selectable from terminal block
Max. length of connections	100m
Operating temperature	-30...55°C
Max surrounding air temperature	55°C
Storage temperature	-30...70°C
Relative humidity	10%...95%
Maximum operating altitude	2000m
Vibration resistance (CEI EN 60068-2-6:2009)	+/- 1.5 mm 9...200 Hz
Bump resistance (CEI EN 60068-2-27:2012)	15 g (6 ms half-sine)
ENCLOSURE DATA	VALUE
Description	Electronic housing 24 pole, with locking latch mounting
Enclosure protection rating	IP 20
Terminal block protection rating	IP 2X
Fastening	Fast attachment to rail according to CEI EN 60715
Dimensions (h x w x d)	99mm x 35mm x 113,5mm
Weight	200g

## DIMENSIONS

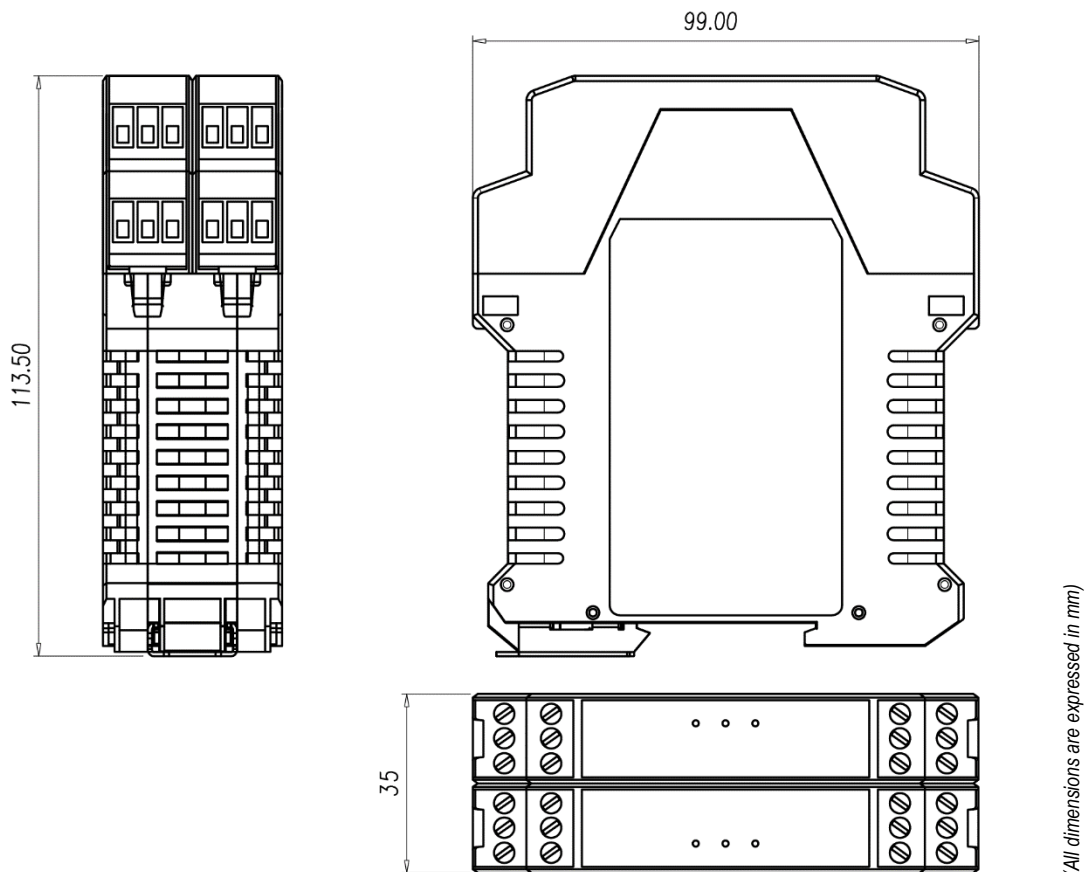

Figure 10

---

**INDICATIONS AND INFORMATION FOR ENVIRONMENTAL PROTECTION**

---

Dispose of the product in an eco-compatible manner and in accordance with national legislation.

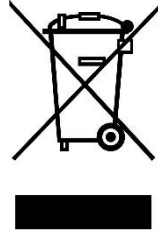
**For Countries in the European Union:**

**Pursuant to the Directive no. 2012/19/EU on waste electrical and electronic equipment (WEEE).**

The crossed out wheeled-bin symbol on the equipment or its packaging means that when the product reaches the end of its useful life it must be collected separately from other waste.

Proper separate collection of the discarded equipment for later environment-friendly recycling, processing, and disposal, helps to avoid any negative impact on the environment and health and encourages re-use and recycling of the materials the equipment is made of.

In each individual Member State of the European Union this product is required to be disposed of in accordance with Directive 2012/19/EU as implemented in the Member State where the product is disposed of.

For further information please contact Reer or your local dealer.

## WARRANTY

ReeR warrants that each SR ONE M unit in new ex-factory condition, in conditions of normal use, is free of defects in the materials and of manufacturing defects for a period of 12 (twelve) months.

In this period, ReeR undertakes to eliminate any faults in the product through repair or replacement of the faulty parts, completely free of charge as regards material and labour. However, ReeR reserves the right to replace the entire faulty appliance with another equivalent appliance or with the same characteristics instead of repairing this.

Validity of this warranty is regulated by the following conditions:

- The user must inform ReeR of the fault within twelve months from the date of delivery of the product.
- The appliance and its components must be in the conditions in which they were delivered by ReeR.
- The serial numbers must be clearly legible.
- The fault or defect has not been caused directly or indirectly by:
  - Improper use;
  - Non-compliance with instructions for use;
  - Carelessness, inexperience, incorrect maintenance;
  - Repairs, modifications, adaptations not carried out by ReeR personnel, tampering, etc.;
  - Accidents or impacts (also due to transportation or causes of force majeure);
  - Other causes not to be ascribed to ReeR.

Repairs will be carried out at the ReeR laboratories to which the material must be delivered or dispatched: transport risks and the risks of any damage or loss of the material during shipment are the responsibility of the user.

All products and components replaced become the property of ReeR.

ReeR does not recognize any other warranties or rights except for those specifically described above; therefore, no claims for damages may be submitted for expenses, interruption of business or other factors or circumstances in any way related to failure of the product or of one of its parts.

 Precise, complete compliance with all the rules, instructions and prohibitions indicated in this handbook is an essential requirement for correct functioning of the device.

 ReeR s.p.a. therefore declines any responsibility for all and anything resulting from failure to comply, even partially, with such indications.

*Characteristics subject to change without notice. • Total or partial reproduction is forbidden without the prior authorization of ReeR.*



**EC DECLARATION OF CONFORMITY****Dichiarazione CE di conformità  
EC declaration of conformity**

Torino, 19/09/2022

REER SpA  
via Carcano 32  
10153 – Torino  
Italy

dichiara che i moduli di sicurezza **SR SELECT / SR ONE / SR ONE M / SR T / SR E4 / SR E4C** sono Dispositivi Elettrosensibili di Sicurezza (ESPE) di:

- **Tipo 4** (secondo la Norma **EN IEC 61496-1:2020**)
- **SIL 3** (secondo la Norma **EN 61508:2010**)
- **SILCL 3** (secondo la Norma **EN 62061 + A2:2015**)
- **PL e** (secondo la Norma **EN ISO 13849-1:2015**)

declares that the safety interface **SR SELECT / SR ONE / SR ONE M / SR T / SR E4 / SR E4C** are Electro-Sensitive Safety Devices (ESPE) of:

- **Type 4** (according the Standard **EN IEC 61496-1:2020**)
- **SIL 3** (according the Standard **EN 61508:2010**)
- **SILCL 3** (according the Standard **EN 62061 + A2:2015**)
- **PL e** (according the Standard **EN ISO 13849-1:2015**)

realizzati in conformità alle seguenti Direttive Europee:  
*complying with the following European Directives:*

- **2006/42/EC** "Direttiva Macchine"  
"Machine Directive"
- **2011/65/EU** "RoHS – Linea Guida"  
"RoHS – Guideline "
- **2014/30/EU** "Direttiva Compatibilità Elettromagnetica"  
"Electromagnetic Compatibility Directive"

e alle seguenti Norme: /and to the following Standards:

- **EN 55032: 2015**
- **EN IEC 63000: 2018**

e sono identici all'esemplare esaminato ed approvato con esame di tipo CE da:  
*and are identical to the specimen examined and approved with a CE - type approval by:*

**TÜV SÜD Product Service GmbH – Zertifizierstelle – Ridlerstraße 65 – 80339 – München – Germany**  
**N.B. number: 0123 - Certificate number: Z10 024820 0085 Rev. 01**

Responsabile per la documentazione tecnica:  
*Responsible person for technical documentation:*

Carlo Pautasso

**Carlo Pautasso**  
Direttore Tecnico  
Technical Director

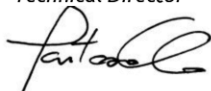

**Simone Scaravelli**  
Amministratore Delegato  
Managing Director

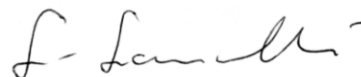

---

**UKCA DECLARATION OF CONFORMITY**

---

ReeR declares that SR ONE M Safety Relay module complies with following UK legislation:

- S.I. 2008 No. 1597 - The Supply of Machinery (Safety) Regulations
- S.I. 2016 No. 1101 - Electrical Equipment (Safety) Regulations
- S.I. 2016 No. 1091 - Electromagnetic Compatibility Regulations
- S.I. 2012 No. 3032 - The Restriction of the Use of Certain Hazardous Substances in Electrical and Electronic Equipment Regulations

→ Please refer to the link <https://www.reersafety.com/certifications> to download the complete UKCA Declaration of Conformity.





Via Carcano, 32  
10153 Torino, Italy  
T +39 011 248 2215  
F +39 011 859 867  
[www.reersafety.com](http://www.reersafety.com)  
[info@reer.it](mailto:info@reer.it)

