

# MAYSER®

## Polymer Electric

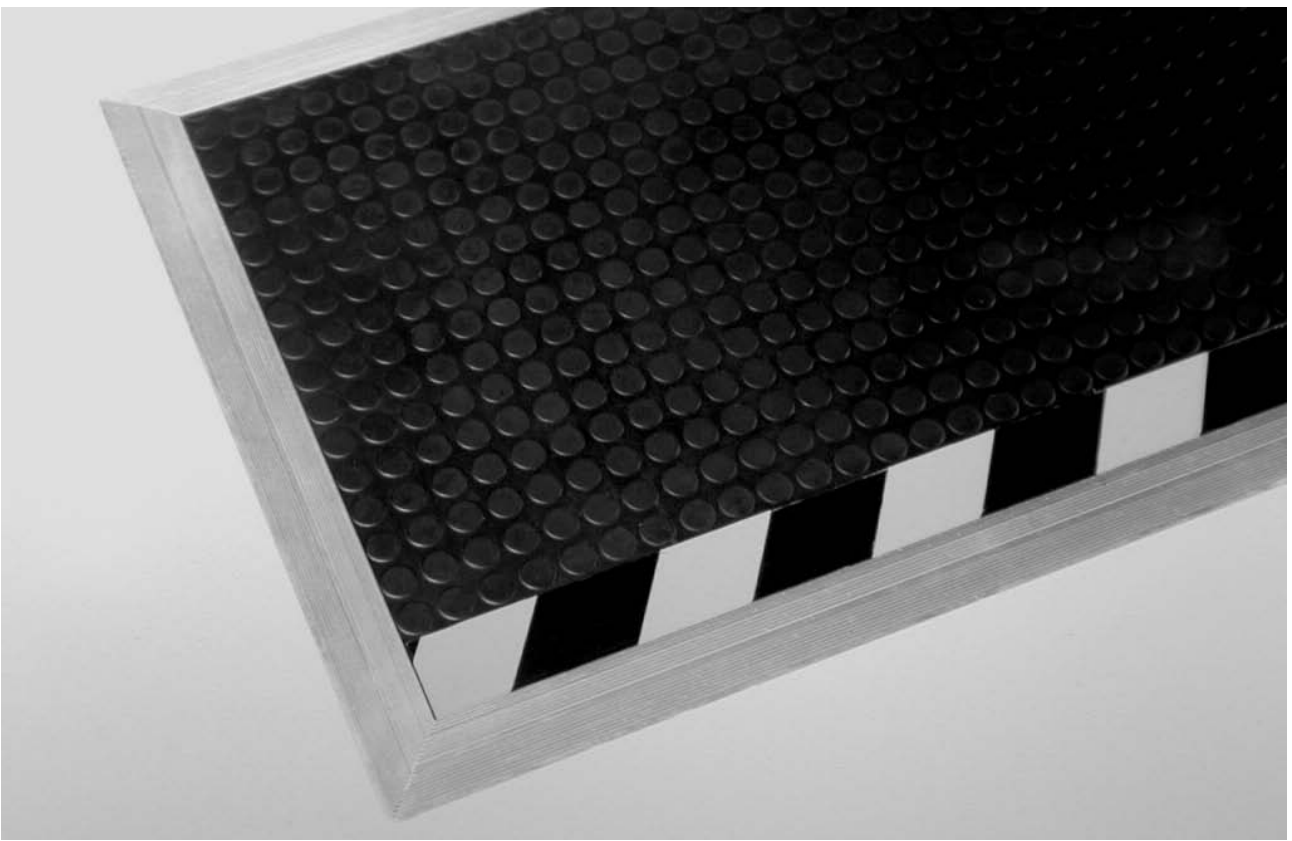

### Installation Instructions



## Safety Mats SM

**MAYSER®** GmbH & Co. KG  
Polymer Electric  
Örlinger Straße 1-3  
89073 Ulm  
GERMANY  
Tel.: +49 731 2061-0  
Fax: +49 731 2061-222  
E-Mail: [info.ulm@mayser.de](mailto:info.ulm@mayser.de)  
Internet: [www.mayser.com](http://www.mayser.com)

Original instructions

---

## Contents

<b>About these installation instructions .....</b>	<b>3</b>
<b>Safety .....</b>	<b>4</b>
Intended use.....	4
Safety label on the product.....	4
Residual dangers .....	5
Applicable standards .....	5
<b>Technical Data .....</b>	<b>6</b>
<b>Transport and storage.....</b>	<b>6</b>
Packaging and transport.....	6
Storage.....	6
<b>Installation.....</b>	<b>7</b>
Preparing the installation site .....	7
Unpacking .....	8
Laying out the Safety Mats .....	9
Installing Z-profiles .....	10
Positioning the Safety Mats .....	11
Rampenschienen AK 66 montieren.....	12
Installing two-part Ramp Edges AK 105 and AK 105/1 .....	14
Installing lower sections of the ramp rails.....	14
Installing upper sections of the ramp rails.....	15
Laying cables.....	16
Testing.....	19
<b>Maintenance and cleaning.....</b>	<b>20</b>
<b>Disposal.....</b>	<b>20</b>

### Copyright

The reproduction, distribution and utilization of this document as well as the communication of its contents without express authorization is prohibited. Offenders will be held liable for the payment of damages. All rights reserved in the event of the grant of a patent, utility model or design.

© Mayser Ulm 2013

## About these installation instructions

These installation instructions are part of the product.

Mayser Polymer Electric accepts no responsibility or warranty claims for damage and consequential damage due to failure to observe the installation instructions.

- ➔ Read installation instructions carefully before use.
- ➔ Keep installation instructions for the complete service life of the product.
- ➔ Pass installation instructions on to every subsequent owner or user of the product.
- ➔ Add any supplement received from the manufacturer to the installation instructions.

### Validity

These installation instructions are only valid for the products specified on the title page.

### Target group



The target group of these installation instructions are operators and trained specialist personnel who are familiar with installation and commissioning.

### Other applicable documents

- ➔ The following documents are to be observed in addition to the installation instructions:
  - drawing of the Safety Mat system (optional)
  - wiring diagram (optional)
  - operating instructions of the Control Unit used

Symbol	Meaning
➔ ...	Action with one step or with more than one step where the order is not relevant.
1. ... 2. ... 3. ...	Action with more than one step where the order is relevant.
• ... - ...	Bullets first level Bullets second level
(see <i>Assembly</i> )	Cross-reference

**Danger symbols and information**

Symbol	Meaning
<p><b>DANGER</b></p> 	Immediate danger leading to death or serious injury.
<p><b>CAUTION</b></p> 	Possible danger which may lead to slight injury or damage to property.
	Information on easier and safer working practices.

## Safety

### Intended use

The product is designed as a pressure-sensitive protective device for protecting areas. Individual sensors are activated by persons weighing more than 20 kg stepping on them. Combinations of sensors are activated by persons weighing more than 35 kg stepping on them.

### Safety label on the product

A label is attached to the underside of every Safety Mat with symbols which warn against damage to the Safety Mat. In addition, you will find our contact address there.

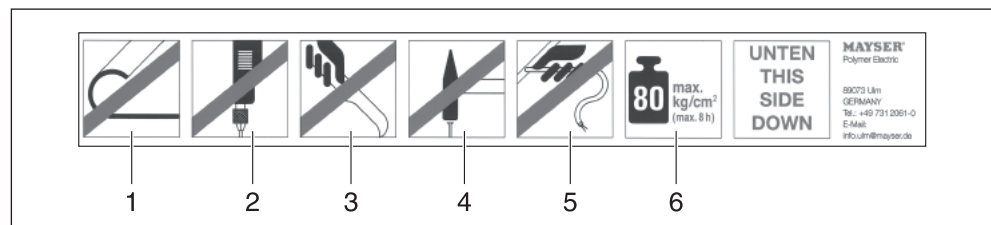

- 1 Do not allow Safety Mat to bend or sag.
- 2 Do not make holes or cut-outs in the Safety Mat.
- 3 Do not cut Safety Mat.
- 4 Do not hammer or screw any objects (nails, screws etc.) into the Safety Mat.
- 5 Do not use the cable as a carrying handle.
- 6 The maximum load bearing capacity of the Safety Mat is 80 kg/cm<sup>2</sup> (up to 8 hrs.).

## Residual dangers

### Non-sensitive edges

The edges of the Safety Mats are not sensitive (40 mm on the cable exit side, 10 mm on all other sides). When non-sensitive areas are stepped on, the protective function of the Safety Mat is not active.

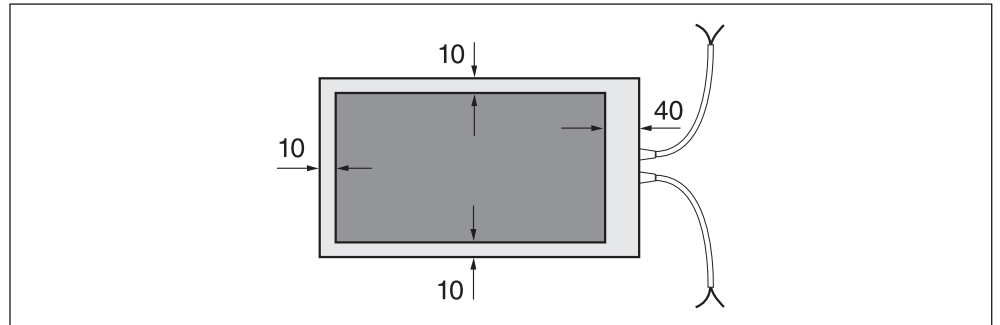

- ➔ Install Safety Mats wherever possible in direct contact with the source of danger.
- ➔ When installing more than one Safety Mat, ensure that cable exit sides always remain clear.
- ➔ At the danger source, place a covering over parts (surfaces, cross struts etc.) which could be used as a tread.
- ➔ When positioning the Safety Mats, observe the standard EN ISO 13855 “Safety of machinery – Positioning of safeguards with respect to the approach speeds of parts of the human body:“

### Replacement parts

When using non-OEM replacement parts, the safety of the Safety Mats may be impaired..

- ➔ Only use OEM replacement parts from Mayser.

## Applicable standards

The construction type of the product complies with the EC Machinery Directive 2006/42/EC and EMC Directive 2004/108/EC.

Applicable standards:

- EN 1760-1 “Safety of machinery – Pressure-sensitive protective devices – Part 1: pressure-sensitive mats and pressure-sensitive floors“
- IEC 61508 “Functional safety of safety-related electrical/ electronic/ programmable electronic systems“
- ISO 13849 “Safety of machinery – Safety-related parts of control systems“

These installation instructions were prepared in compliance with EN 62079 “Preparation of instructions – structuring, content and presentation”

## Technical Data

IEC 60529: protection class of sensors	IP65
Actuation forces for signal triggering	in accordance with EN 1760-1
Error behaviour (with SG-EFS 1X4 ZK2/1)	ISO 13849-1:2006 Kategorie 3
Safety integrity level PFH <sub>s</sub> - value	SIL3 in accordance with IEC 61508 9,99 × 10 <sup>-8</sup> × 1/h
Operating temperature individual sensors combination of sensors	-5 to +55 °C +5 to +55 °C
Storage temperature	-20 to +55 °C
Static load (up to 8 hrs)	max. 800 N/cm <sup>2</sup>
Weight of sensor	15 mm: 17,4 kg/m <sup>2</sup> 19 mm: 24,0 kg/m <sup>2</sup>

### Type plate

A type plate is attached to the cable exit on the underside of the Safety Mat for identification of the Safety Mat type. In the event of enquiries, have the specified information to hand

## Transport and storage

### Packaging and transport

The Safety Mats are packed in wooden crates (max. 10 Safety Mats per crate) and can be transported to the installation site with a crane or lifting truck. Depending on the scope of supply, the installation accessories are either included with the Safety Mats or packed separately.

**DANGER**



#### Danger of injury due to components falling!

- ➔ Only use tested, suitable load bearing equipment.
- ➔ Use appropriate load securing devices (e.g. transport belts, anti-slipping devices).
- ➔ Do not stand under suspended loads.

### Storage

- ➔ Store Safety Mats in the original packaging in a dry place.
- ➔ Note and observe storage temperature in accordance with the technical data.

## Installation

### Overview

Install Safety Mats in the following order:

1. Prepare the installation site.
2. Unpack Safety Mats and accessories.
3. Lay out Safety Mats:
  - Z-profiles on sides which are directly adjacent to machine parts or walls
  - ramp rails on sides which are freely accessible
4. Install Z-profiles.
5. Align Safety Mats flush with the installed Z-profiles.
6. Fix Safety Mats with ramp rails.
7. Lay cables.
8. Test function.

### Preparing the installation site

**DANGER**



---

**Danger of injury due to equipment and parts in the vicinity of the installation site (possible electrocution, crushing danger)!**

- ➔ Disconnect all equipment and voltage-carrying parts in the immediate vicinity of the installation site from the power supply and secure against being switched on again (see relevant operating instructions).
- ➔ Check that the equipment or parts are disconnected from the power supply.

---

➔ Preparing the installation surface:

- Create level surface where necessary (e.g. screed). There must not be any holes with a diameter of more than 20 mm nor any variations in floor height.
- Remove dirt particles.
- Ensure that the surface is dry.

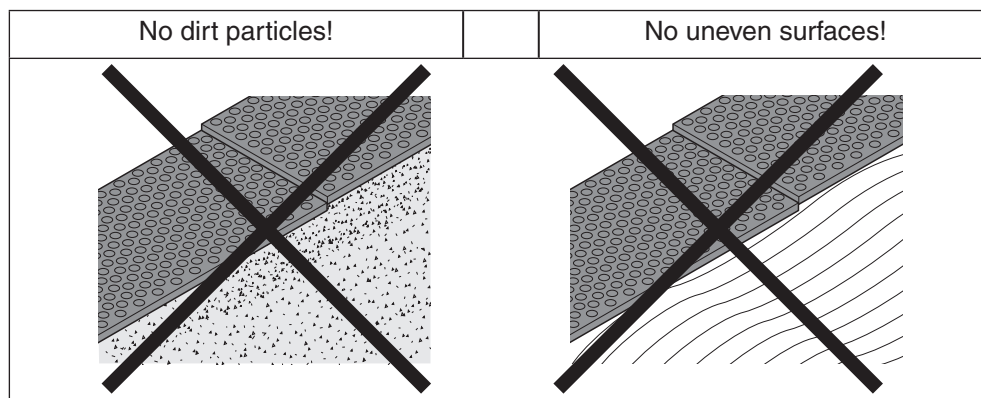

➔ Provide necessary tools.

## Unpacking

**CAUTION**





**Damage to property due to incorrect handling!**

Safety Mats can be damaged by bending or due to the effects of sharp objects.

- ➔ Always transport Safety Mats upright to prevent sagging.
- ➔ Safety Mats are always to be transported using 4 hands.
- ➔ Only place Safety Mats on a level, dirt-free, dry surface.
- ➔ Do not use the connection cable of the Safety Mats as a carrying handle.

1. Check that the contents of the packaging are undamaged.
2. Ensure that the ramp rails and Z-profiles supplied correspond with the overall height of the Safety Mat. See following table.

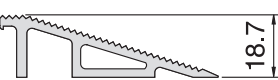
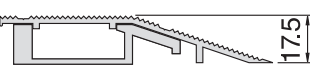
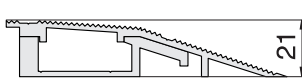
	Overall height	
	15 mm	19 mm
Z-Profil	Z 	Z/1 
Ramp Edges	AK 66  oder AK 105 	AK 105/1 



## Laying out the Safety Mats

1. Approximately arrange Safety Mats (possibly in accordance with the drawing of the Safety Mat system). Observe the following:
  - lay the Safety Mats in such a way that the structured side is face up and the type plate is face down.
  - lay Safety Mats in such a way that the cable exits are facing in the direction of the ramp rails.
2. Check the resistance between the two wire ends of the cable of each Safety Mat with an ohmmeter.  
The measured resistance must have the following value:
  - Sensor W: 1k2 Ohm  $\pm$  2%
  - Sensor BK: > 1 MOhm



---

BK type: Ensure that no short circuit can ensue between the strands of the second cable!

---

3. Arrange all fixing rails (ramp rails, Z-profiles) at a short distance from their final position in order to arrange the Safety Mats.

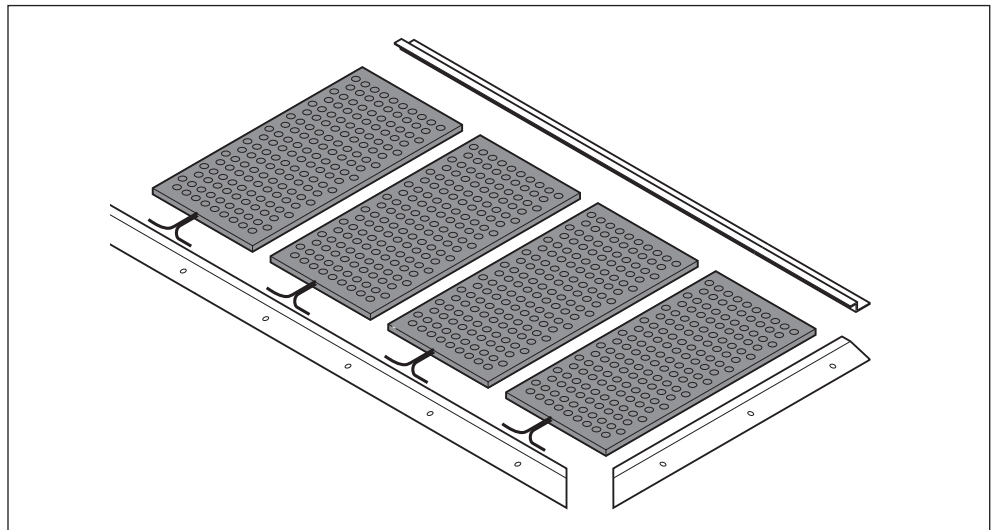

## Installing Z-profiles

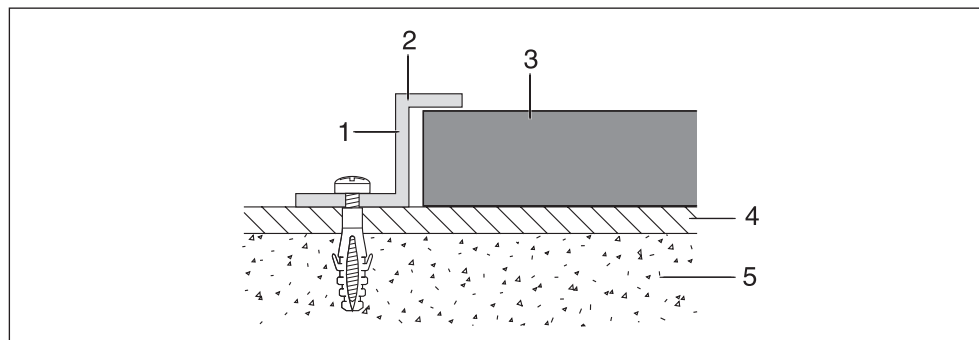

- 1 Stop ridge  
 2 Z-profil  
 3 Safety Mat

- 4 Plant floor  
 5 Screed

### CAUTION



#### Danger of tripping!

There is a risk of tripping on a side which is bordered by a Z-profile.

➔ Only install Z-profile on sides directly adjacent to machine parts or walls.

1. Draw a line, along which the Z-profiles are to be installed, on the ground.
2. Position Safety Mats on line.
3. Place Z-profiles on the Safety Mat edges
  - For installation of the first side: Push stop ridges of the Z-profiles against the Safety Mat edges.
  - When installing further sides: Mark 2 mm to Safety Mat edge and align Z-profiles

The Safety Mat edge must be covered by the upper ridge of the Z-profiles.
4. Mark corners of the Safety Mat system on the Z-profiles.
5. Saw off Z-profiles at the places marked and cut to size accordingly.
6. Where necessary, drill holes in the stop ridges of the Z-profiles for cable exits.

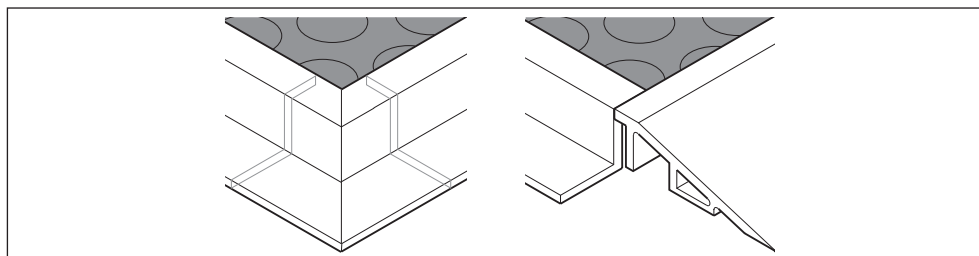

7. Remove burrs on holes and interfaces.
8. Re-position Z-profiles:
  - For installation of the first side: Align Z-profiles on the line marked on the installation surface.
  - When installing further sides: Align Z-profiles along the marking on the Safety Mat edge .
9. Fix Z-profiles to installation surface with plugs (Ø 6 mm) and screws (Ø 4 mm, length: min. 40 mm) at intervals of 50 to 70 cm.
10. Remove drilling dust ( e.g. with a vacuum cleaner), as otherwise the drilling dust could get under the Safety Mats and the ramp rails and lead to unevenness.

## Positioning the Safety Mats

1. Push Safety Mats against the installed Z-profiles.
  - For installation of the first side: Push Safety Mats against the stop ridges of the Z-profiles.
  - When installing further sides: Mark 2 mm to Safety Mat edge and align Z-profiles
2. Place all Safety Mats edge to edge. Observe the following:
  - Arrange all cable exit sides in the same direction.
  - Ensure that the distances between the Safety Mats are not more than 1 mm.
  - Do not compress or bend Safety Mats.
  - Ensure that there are no gradings on the Safety Mat edges.

## Rampenschienen AK 66 montieren

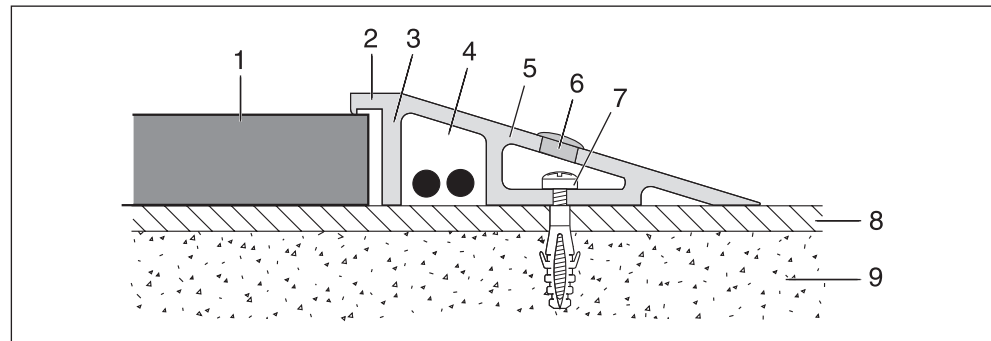

- |                                 |                |
|---------------------------------|----------------|
| 1 Safety Mat                    | 6 Sealing plug |
| 2 Cover ridge                   | 7 Fixing screw |
| 3 Stop ridge                    | 8 Plant floor  |
| 4 Cable conduit (max. 2 cables) | 9 Screed       |
| 5 Ramp Edge AK 56               |                |



Due to heat expansion of the Safety Mats, the ramp rails must be installed at room temperature in such a way that an air gap of approx. 3 mm wide exists between the edge of the Safety Mat and the stop ridge (3) of the ramp rail, as otherwise the Safety Mats may arch at high temperatures.

1. Mark the Safety Mats with a pen( e.g. ballpoint pen) at intervals of 2 mm from the outer edges of the Safety Mat system.

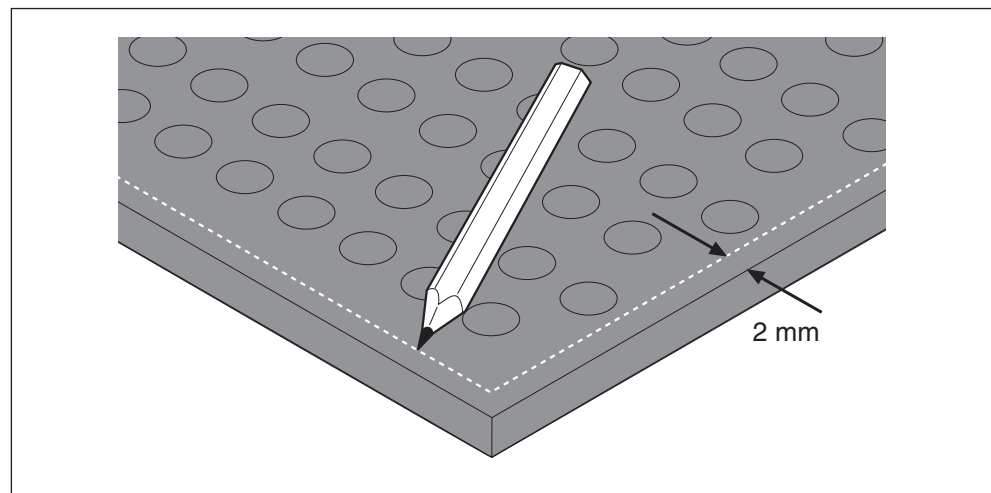

The ramp rails are aligned with these marks so that an air gap of 3 mm remains between the edge of the Safety Mat and the stop ridge of the ramp rails

2. Place the ramp rails against the Safety Mats and align the edges of the cover ridge with the marks.
3. Mark corners of the Safety Mat system and if necessary cable exits on the ramp rails.

4. Saw off ramp rails at the places marked and cut to size accordingly. zuschneiden.

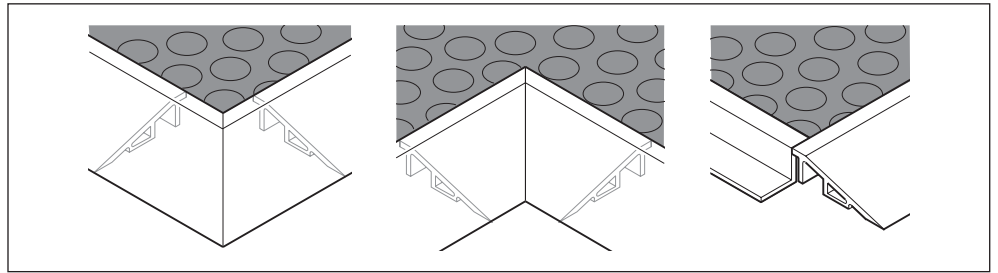

5. If necessary, mark cable exits on the stop ridges and cut out as follows:
  - Saw right into the stop ridge at every point marked at intervals of approx. 10 mm.
  - Break off the piece between the saw cuts with pliers.
6. Remove burrs on edges.
7. Place the ramp rails against the Safety Mats and align the edges of the cover ridge with the marks.
8. Drill holes in ramp rails and installation surface at intervals of 50 to 70 cm so that the ramp rails can be fixed to the installation surface with plugs (Ø 6 mm) and screws (Ø 4.5 mm, length: min. 40 mm).
9. Remove burrs on holes.
10. Remove ramp rails.
11. Clean ramp rails, installation surface and holes of drilling dust (e.g. with a vacuum cleaner), as otherwise the drilling dust could get under the Safety Mats and the ramp rails and lead to unevenness.
12. Insert plugs (Ø 6 mm) into the holes in the installation surface.
13. Place ramp rails against the Safety Mats again.
14. Thread cables through the cable exits and cable conduit.
15. Align the edges of the cover ridges with the markings on the Safety Mats.
16. Fix ramp rails to installation surface with screws (Ø 4.5 mm, length: min. 40 mm).
17. Push sealing plugs (optional) into the graduated bore holes.

## Installing two-part Ramp Edges AK 105 and AK 105/1

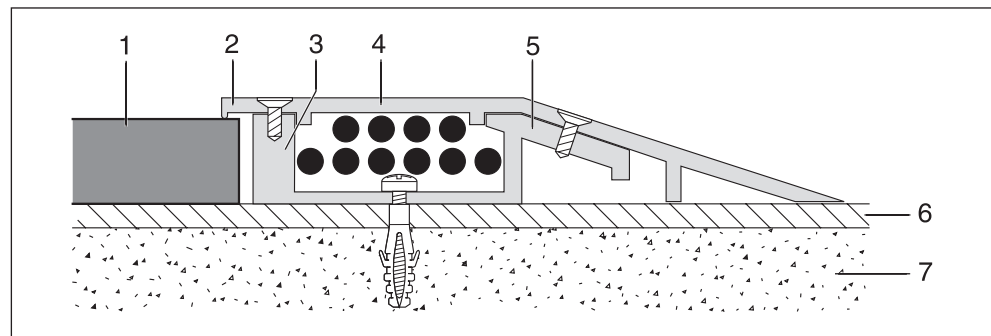

- |   |                         |   |   |
|---|-------------------------|---|---|
| 1 | Safety Mat              | 5 | Lower section ramp rail (with cable conduit for max. 10 cables) |
| 2 | Cover ridge             | 6 | Plant floor   |
| 3 | Stop ridge              | 7 | Screed  |
| 4 | Upper section ramp rail |   |   |



Due to heat expansion of the Safety Mats, the ramp rails must be installed at room temperature in such a way that an air gap of approx. 3 mm wide exists between the edge of the Safety Mat and the stop ridge (3) on the lower section of the ramp rail, as otherwise the Safety Mats may arch at high temperatures.

### Installing lower sections of the ramp rails

1. Place lower sections against the Safety Mats at a distance of 3 mm.
2. Mark corners of the Safety Mat system and if necessary cable exits on the lower sections.
3. Saw off lower sections at the places marked and cut to size accordingly.

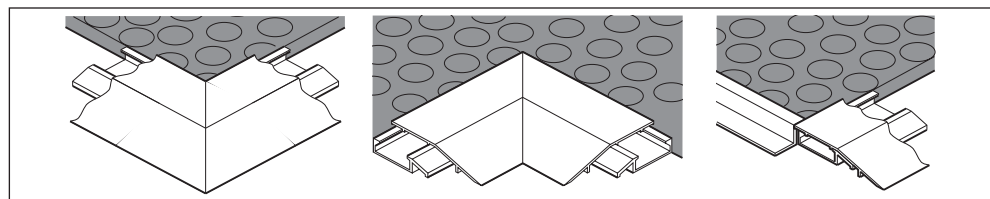

4. If necessary, mark cable exits on the stop ridges and cut out as follows:
  - Saw right into the stop ridge twice at the points marked at a distance of approx. 10 mm.
  - Break off the piece between the saw cuts with pliers.
5. Remove burrs on edges.
6. Place cut lower sections against the Safety Mats again with a 3 mm gap.
7. Drill holes in lower sections and installation surface at intervals of 50 to 70 cm

so that the lower sections can be fixed to the installation surface with plugs (Ø 6 mm) and screws (Ø 4,5 mm, length: min. 40 mm).

8. Remove lower sections.
9. Remove burrs on holes.
10. Clean lower sections, installation surface and holes of drilling dust (e.g. with a vacuum cleaner), as otherwise the drilling dust could get under the Safety Mats and the ramp rails and lead to unevenness.
11. Insert plugs (Ø 6 mm) into the holes in the installation surface.
12. Place lower sections against the Safety Mats again.
13. Thread cables through the cable exits and lower sections.
14. Fix lower sections to installation surface with screws (Ø 4,5 mm, length: mind. 40 mm).

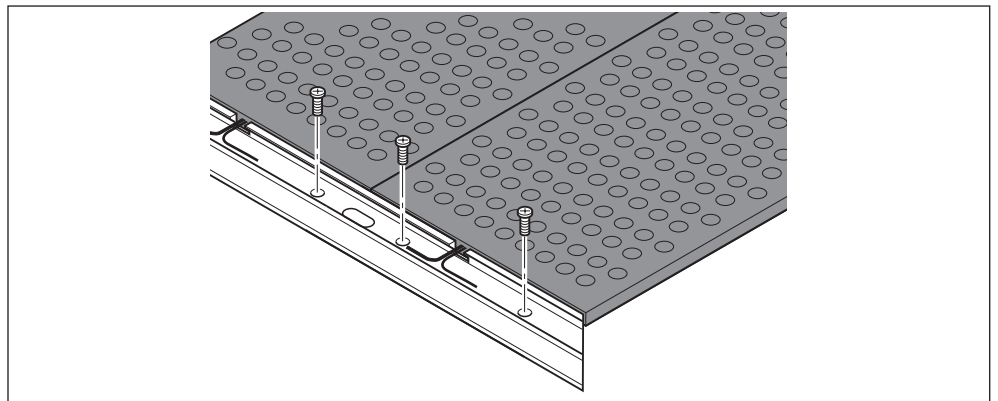

### Installing upper sections of the ramp rails

1. Place upper sections of the ramp rails onto the installed lower sections.
2. Mark corners of the Safety Mat system on the upper sections.
3. Saw off upper sections at the points marked.
4. Remove burrs on edges.
5. Place upper sections on lower sections again.

6. Screw upper sections onto lower sections with thread rolling screws (M6).

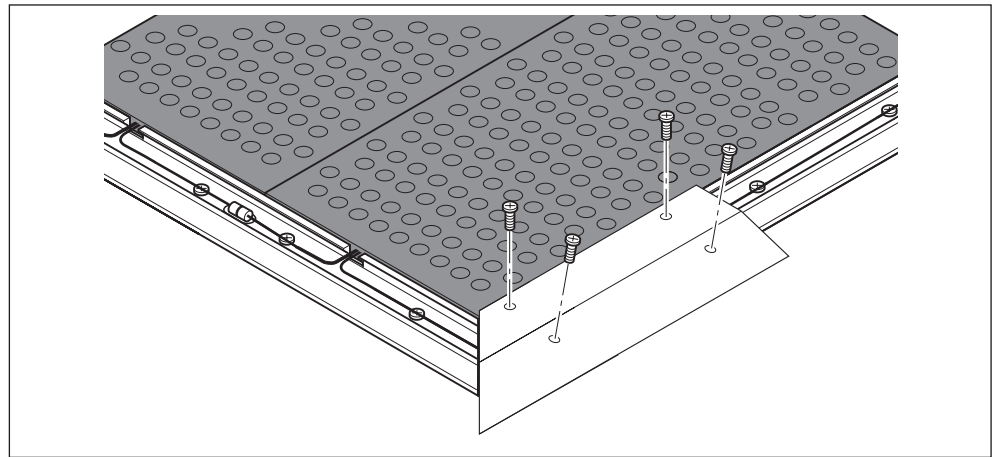

## Laying cables

The type of cabling depends on the operation principle of your system.

1. Wire up Safety Mats in accordance with wiring diagram (optional) or in accordance with the wiring technologies described below.

Observe the following:

- Connect the wire ends of the Safety Mats in accordance with the colour coding.
- If no plugs and sockets are available (optional), insulate soldering points and seal with heat-shrinkable sleeves.
- Wire each zone separately and route the cables to a separate Control Unit.

### CAUTION



---

#### Damage to cables due to incorrect laying!

- ➔ Do not pinch or bend cables.
- 

2. Lay cable and feed via safety barrier to Control Unit.

The multi-functional cut-out on the cable exit of the Safety Mat also allows the cable to be laid downwards.



**Key to the following wiring diagrams:**

BK	Safety Mat with two-sided cables as feed-through sensors or for connection of an external monitoring resistor.
W	Safety Mat with integrated monitoring resistor
R	Resistor for functional monitoring of the system(1.2 kΩ ± 2%)
SG	Control Unit
D	Sub-distribution with series terminals

**Farbkennung:**

bl blue  
br brown

sw black  
ws white

**Safety Mats BK:  
2-wire technology**

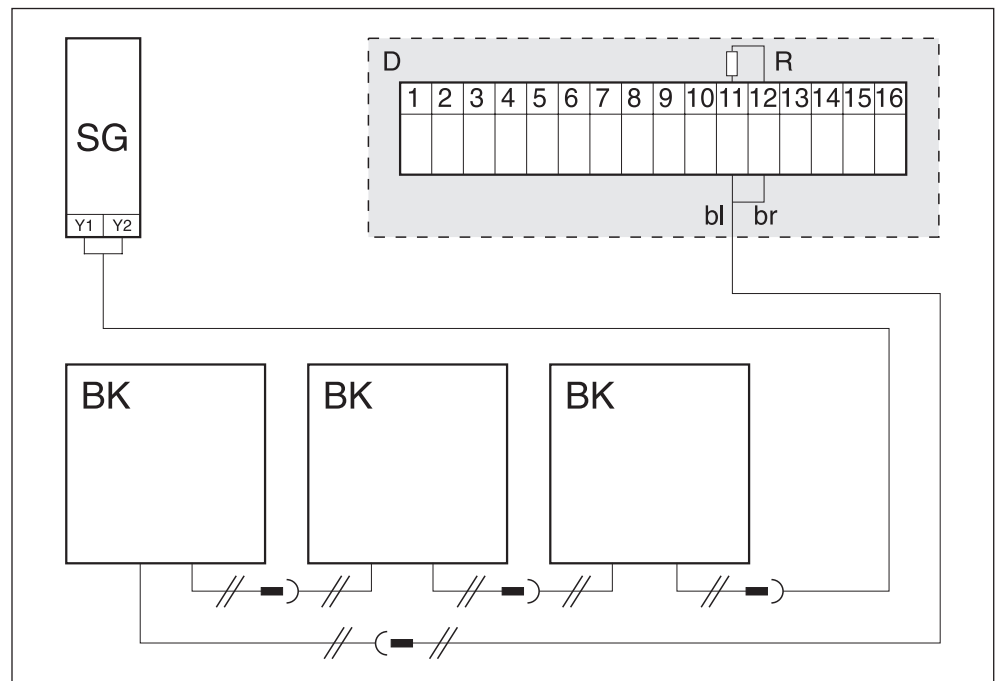

*Wiring of the Safety Mats BK for 2-wire technology.*

**Safety Mats BK:  
2-wire technology with  
terminal connector  
(optional)**

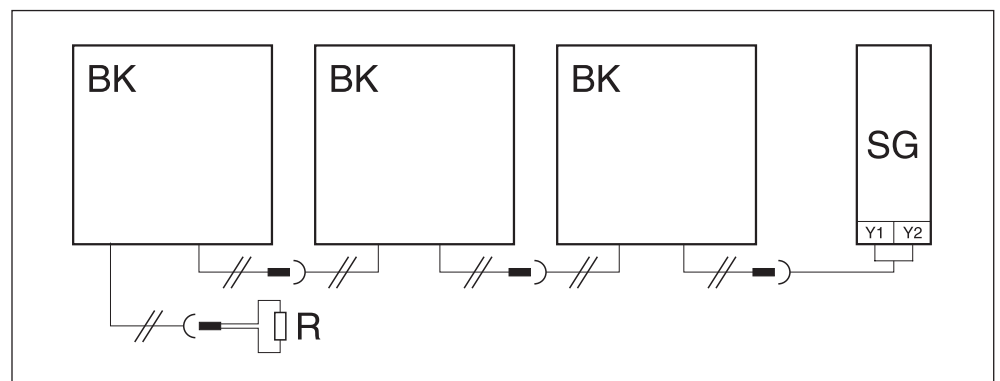

*Wiring of Safety Mats BK for 2-wire technology with optional terminal connector, in which the resistor R is integrated.*

**Safety Mats  
W and BK:  
2-wire technology  
wired straight to the  
Control Unit**

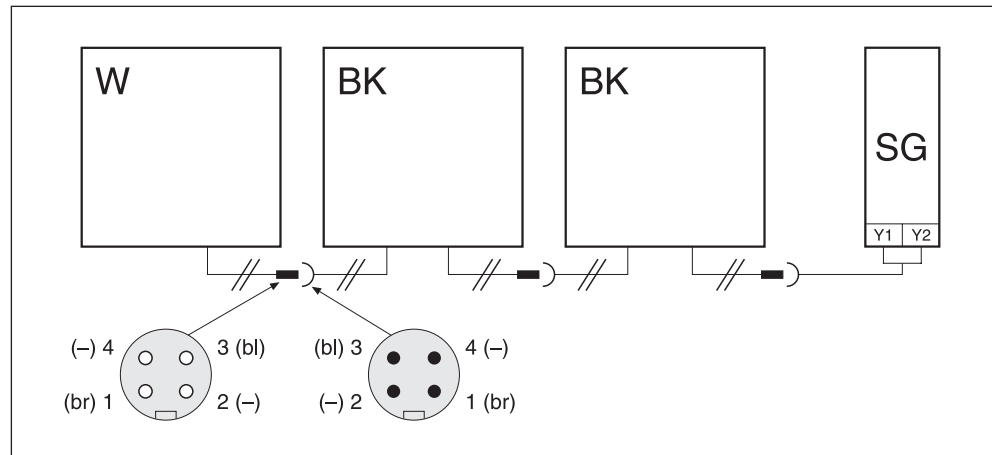

*Wiring of the Safety Mats W and BK for 2-wire technology*

**Safety Mats  
W and BK:  
2-wire technology  
via sub-distribution  
system**

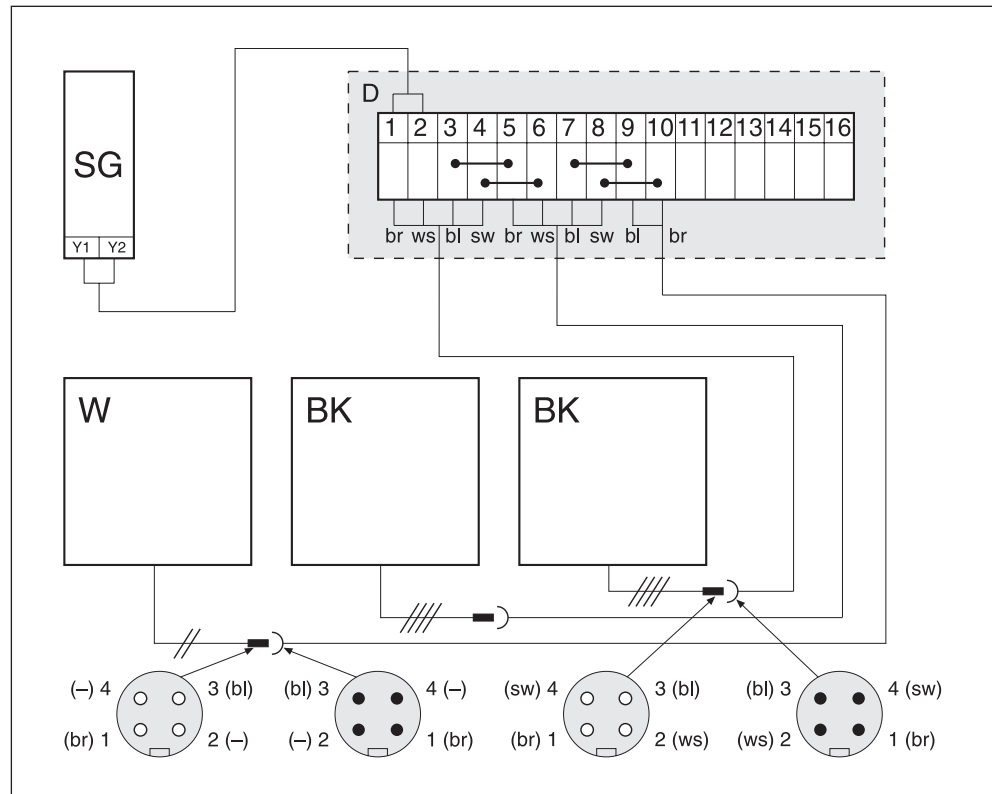

*Wiring of the Safety Mats for 2-wire technology via sub-distribution system*

**Safety Mats BK:  
4-wire technology**

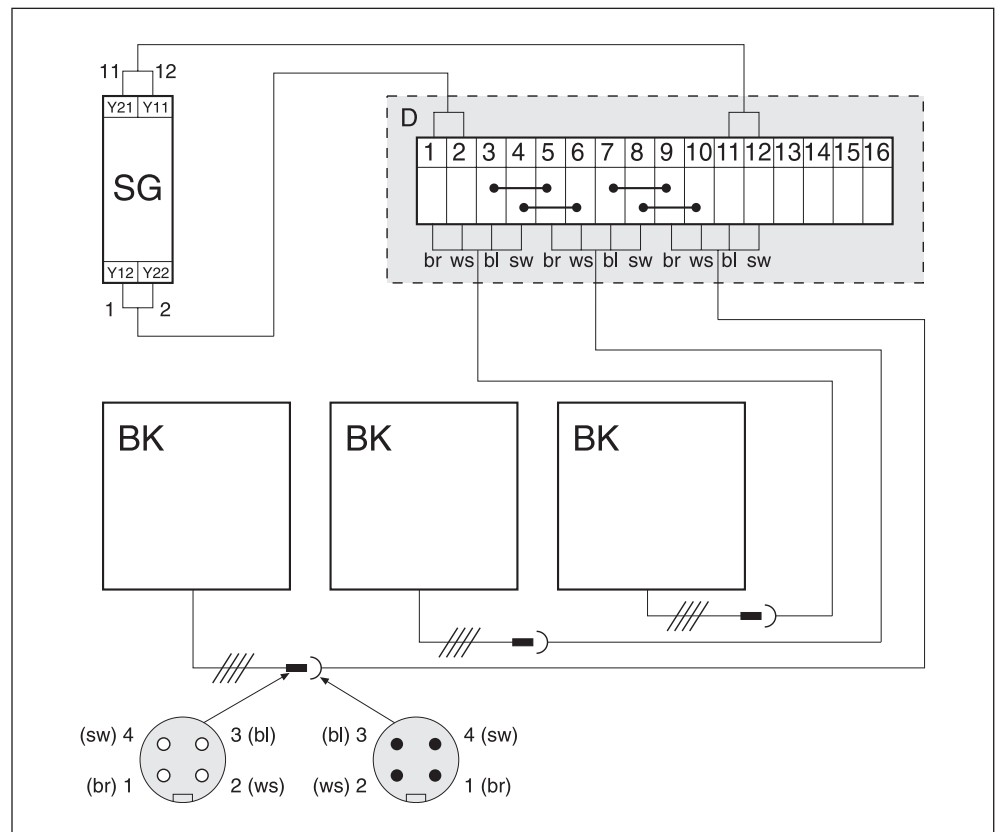

*Wiring of the Safety Mats BK for 4-wire technology*

## Testing

Carry out the following actions for every cable of the Safety Mat system:

1. Set ohmmeter for measuring in a high resistance range.
2. Connect ohmmeter to the two wires of the cable.
3. Measure the electrical resistance between the wire ends with activated and non-activated Safety Mat.

The measured resistance must have the following values:

- loaded (activated) Safety Mat system: < 150 Ohm
- not loaded (not activated) Safety Mat system:
  - Sensor W: 1k2 Ohm ± 2%
  - Sensor BK: > 1 MOhm

**Test failed?**

If the resistance measurement does not produce the necessary values, this may have the following causes:

- The cables of the individual Safety Mats are incorrectly connected
- The cables are bent or damaged
- The Safety Mats are not lying flat on the floor

## Maintenance and cleaning

The Safety Mats are virtually maintenance-free.

- ➔ Inspect Safety Mat surfaces for damage at regular intervals.

**DANGER**



---

### In case of damage, failure of the safety function!

- ➔ Immediately put the Safety Mat out of operation as soon as damage is detected which could impair safe operation.
- 

- ➔ Check safety function of the Safety Mats at regular intervals.

### Disposal

- ➔ Clean the surface of the Safety Mats at regular intervals using mild detergents.
- ➔ After cleaning, remove any remaining fluid.

## Disposal

The products included in the scope of supply contain the following materials:

### Safety Mats

- plastics
- graphite (interior of Safety Mat, depending on type)
- aluminium (interior of Safety Mat, depending on type)
- copper (interior of Safety Mat, cables)

### Installation accessories

- steel (screws)
- aluminium (ramp rails, Z-profiles, cable conduits)
- plastics (connecting elements, rubber bungs)

### Packaging

- wood, cardboard, plastics

The following is to be observed when disposing of these materials:

- ➔ Observe all relevant national disposal regulations and statutory conditions.
- ➔ Provide the material list given above when using a disposal company.
- ➔ Recycle or dispose of materials in an environmentally friendly way.