



## DIY Sensor profiles SP



EN | Product information

**Mayser GmbH & Co. KG**

Örlinger Straße 1-3

89073 Ulm

GERMANY

Phone: +49 731 2061-0

Fax: +49 731 2061-222

E-mail: [info.ulm@mayser.com](mailto:info.ulm@mayser.com)

Internet: [www.mayser.com](http://www.mayser.com)

## Content

<b>Overview</b> .....	<b>4</b>
<b>Materials list</b> .....	<b>6</b>
<b>Definitions</b> .....	<b>8</b>
Pressure-sensitive protection device .....	8
Operation principle 2-wire-technology .....	9
Operation principle 4-wire-technology .....	10
<b>Safety</b> .....	<b>12</b>
Intended use .....	12
Limits .....	12
Exclusions .....	12
Other safety aspects .....	13
<b>Design</b> .....	<b>13</b>
Effective actuation area .....	14
Installation position .....	14
<b>Connection</b> .....	<b>15</b>
Cable exits .....	15
Cable connection .....	15
Wire colours.....	16
<b>Sensor surface</b> .....	<b>16</b>
Physical resistance.....	16
Chemical resistance .....	16
<b>Attachment</b> .....	<b>18</b>
Aluminium profiles: Overview of combinations .....	18
Aluminium profile C 15.....	19
Aluminium profile C 25.....	19
Aluminium profile C 25S .....	20
Aluminium profile C 25M.....	20
Aluminium profile C 30.....	21
Aluminium profile C 35.....	21
<b>Maintenance and cleaning</b> .....	<b>22</b>
<b>Technical data</b> .....	<b>23</b>
SK SP 17-3 TPE.....	23
SK SP 37-1 TPE.....	25
SK SP 37-3 TPE.....	27
SK SP 57-2 TPE.....	29

### Copyright

The reproduction, distribution and utilization of this document as well as the communication of its contents without express authorization are prohibited. Offenders will be held liable for the payment of damages. All rights reserved in the event of the grant of a patent, utility model or design.

© Maysers Ulm 2019

SK SP 57L-2 TPE.....	31
SK SP 57-3 TPE.....	33
SK SP 67-2 TPE.....	35
<b>Marking .....</b>	<b>37</b>
<b>Conformity .....</b>	<b>37</b>
EC design test.....	37
<b>UL certification.....</b>	<b>37</b>

## Overview

### Contact profile – Sensor profile

The semi-finished contact profile (4) is cut to length and assembled with the other components. The functioning product is then called a sensor profile.

#### SP 17-3 without end caps

- 1 Countersunk tapping screw
- 2 Closing plug with resistor
- 3 Ear clamp
- 4 Contact profile
- 5 Aluminium profile
- 6 Closing plug with cable

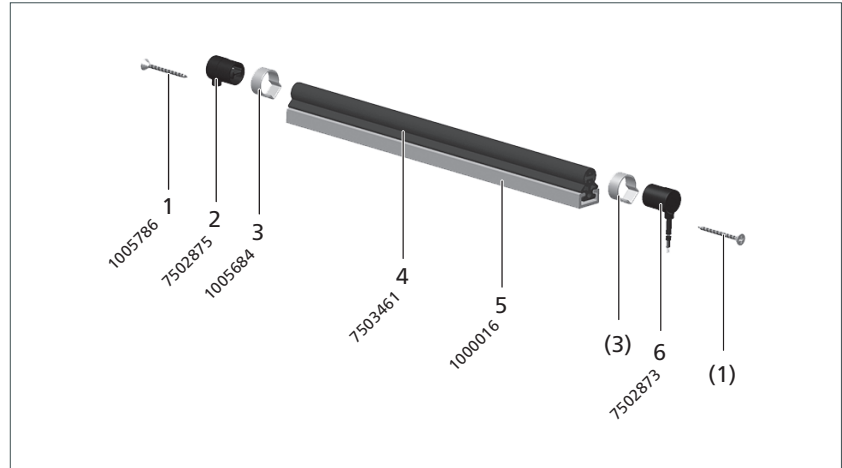

#### SP 37-1 with end caps

- 1 Set of end caps
- 2 Closing plug with resistor
- 3 Ear clamp
- 4 Contact profile
- 5 Aluminium profile
- 6 Closing plug with cable

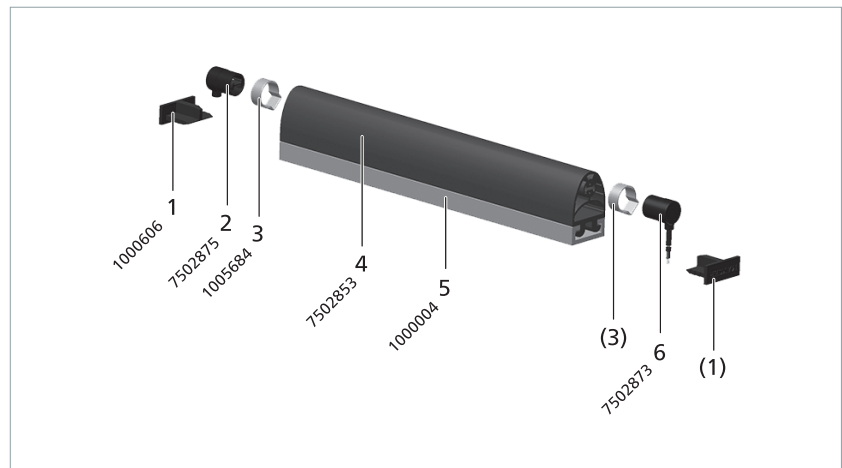

#### SP 37-1 without end caps

- 1 End stoppers
- 2 Closing plug with resistor
- 3 Ear clamp
- 4 Contact profile
- 5 Aluminium profile
- 6 Closing plug with cable

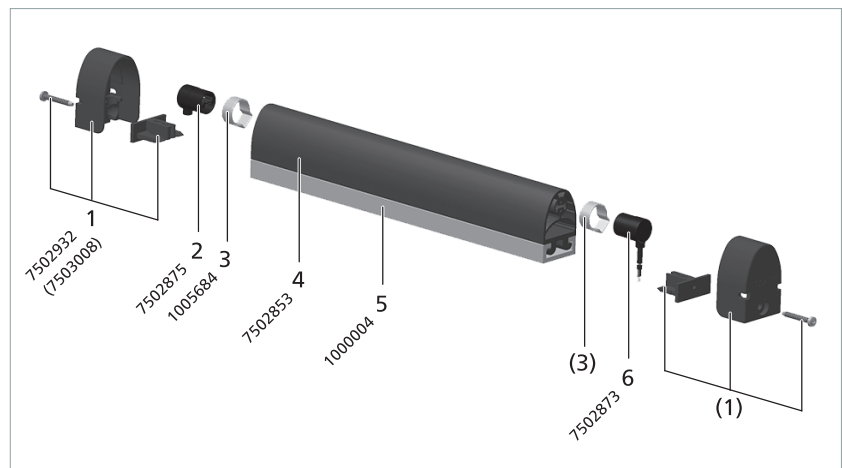

*Subject to technical modifications.*

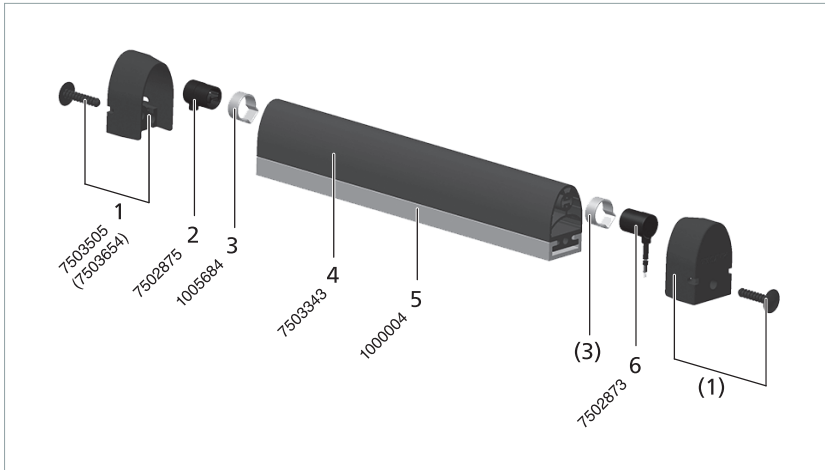

**SP 37-3 with end caps**

- 1 Set of end caps
- 2 Closing plug with resistor
- 3 Ear clamp
- 4 Contact profile
- 5 Aluminium profile
- 6 Closing plug with cable

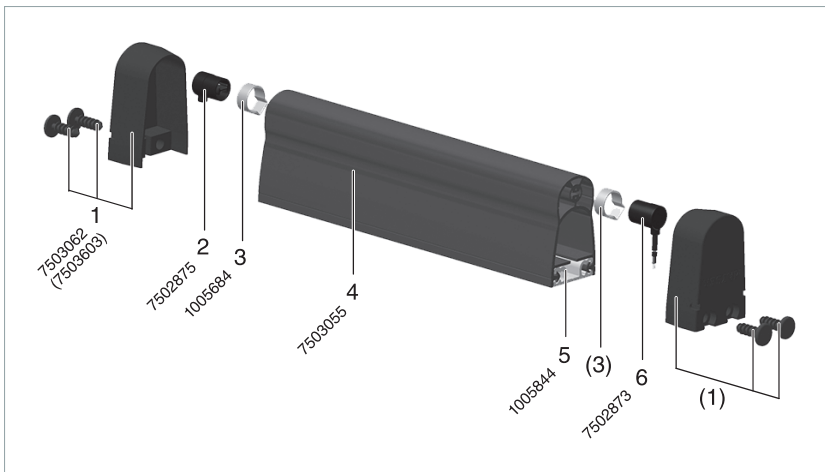

**SP 57-2 with end caps**

- 1 Set of end caps
- 2 Closing plug with resistor
- 3 Ear clamp
- 4 Contact profile
- 5 Aluminium profile
- 6 Closing plug with cable

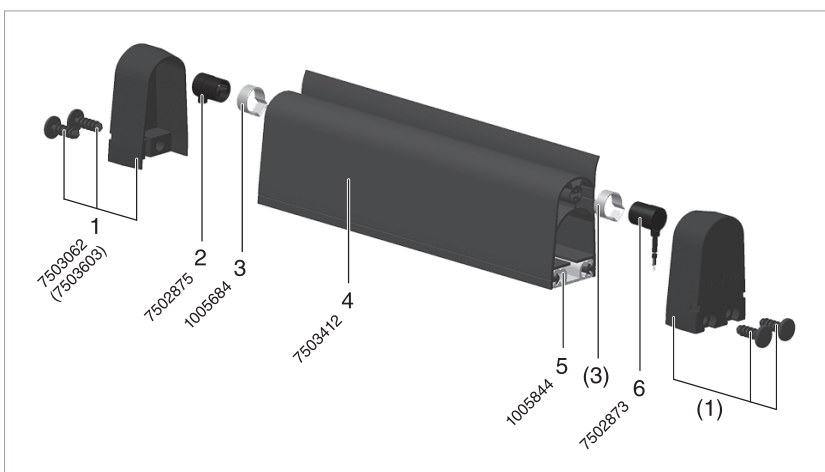

**SP 57L-2 with end caps**

- 1 Set of end caps
- 2 Closing plug with resistor
- 3 Ear clamp
- 4 Contact profile
- 5 Aluminium profile
- 6 Closing plug with cable

## SP 57-3 with end caps

- 1 Set of end caps
- 2 Closing plug with resistor
- 3 Ear clamp
- 4 Contact profile
- 5 Aluminium profile
- 6 Closing plug with cable

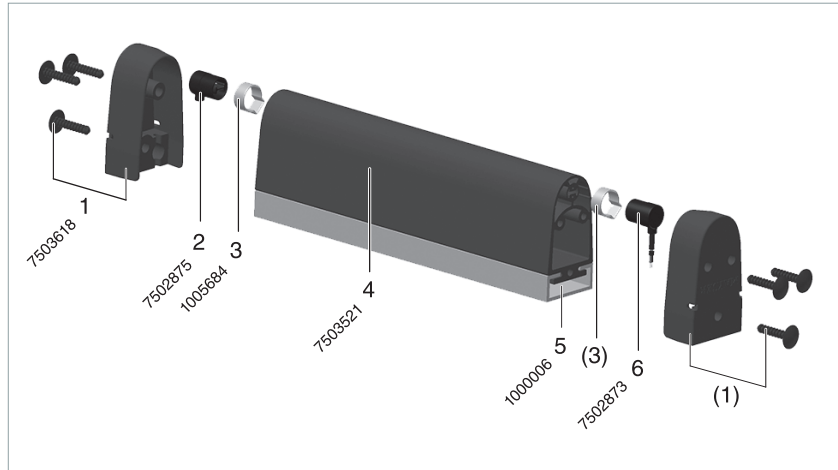

## SP 67-2 with end caps

- 1 Set of end caps
- 2 Closing plug with resistor
- 3 Ear clamp
- 4 Contact profile
- 5 Aluminium profile
- 6 Closing plug with cable

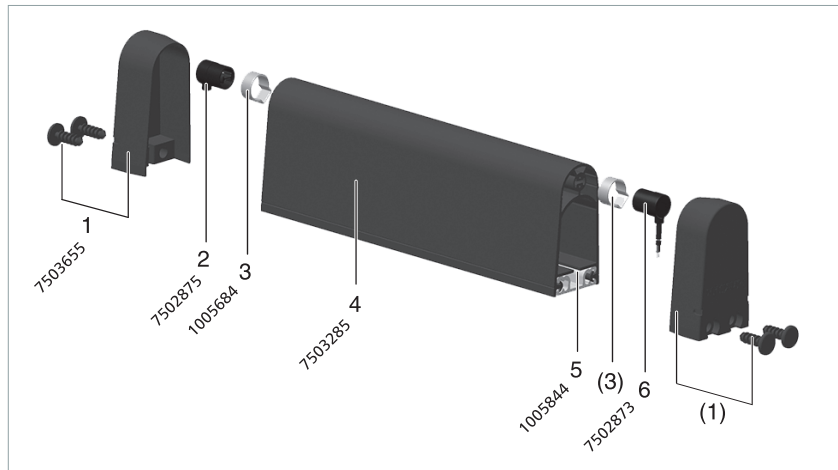

## Materials list

Part No.	Designation	PU
7503461	Contact profile SP 17-3 TPE	80 m
7502853	Contact profile SP 37-1 TPE	30 m
7503343	Contact profile SP 37-3 TPE "black"	30 m
7503534	Contact profile SP 37-3 TPE "red"	30 m
7503055	Contact profile SP 57-2 TPE	30 m
7503412	Contact profile SP 57L-2 TPE	30 m
7503521	Contact profile SP 57-3 TPE	25 m
7503285	Contact profile SP 67-2 TPE	30 m
7502875	Closing plug with resistor 8k2	10 pc.
7502873	Closing plug with PUR cable 2.5 m, angled 90°	10 pc.
1005684	Ear clamp for closing plug	20 pc.

Subject to technical modifications.

Part No.	Designation	PU
7502932	End cap set "hard" for SP 37-1: each containing 2 <b>hard</b> end caps, fixing stoppers and screw 3.9x25	10 pc.
7503008	End cap set "soft" for SP 37-1: each containing 2 <b>soft</b> end caps, fixing stoppers and screw 3.9x25	10 pc.
7503505	End cap set "soft" for SP 37-3 "black": each containing 2 <b>soft</b> end caps and pine tree clip	10 pc.
7503654	End cap set "soft" for SP 37-3 "red": each containing 2 <b>soft</b> end caps and pine tree clip	10 pc.
7503062	End cap set "soft" for SP 57(L)-2: each containing 2 <b>soft</b> end caps, fixing stoppers and 4 screws 5x20	10 pc.
7503603	End cap set "soft" for SP 57(L)-2 with clip: each containing 2 <b>soft</b> end caps and 4 pine tree clips	10 pc.
7503618	End cap set "soft" for SP 57-3: each containing 2 <b>soft</b> end caps and 6 pine tree clips	10 pc.
7503655	End cap set "soft" for SP 67-2: each containing 2 <b>soft</b> end caps and 4 pine tree clips	10 pc.
1005786	Countersunk tapping screw 3.5x25 for SP 17-3	20 pc.
1000016	Aluminium profile C 15	6 m
1000854	Aluminium profile C 25M, upper section	6 m
1000855	Aluminium profile C 25M, lower section	6 m
1000012	Aluminium profile C 25S	6 m
1000004	Aluminium profile C 25	6 m
1005844	Aluminium profile C 30	6 m
1000006	Aluminium profile C 35	6 m
1001223	End stopper for C 25M, for SP without end caps	1 pc.
1000606	End stopper for C 25 or C 25S, for SP without end caps	1 pc.
1004988	Scissors with stop, cutting length 87 mm	1 pc.
7502868	Assembly aid SH3	1 pc.
1005741	Notching pliers Knipex 7742115	1 pc.
1005729	Vice-grip pliers Knipex System Oetiker 1099	1 pc.

## Definitions

### Pressure-sensitive protection device

A pressure-sensitive protection device consists of pressure-sensitive sensor(s), signal processing and output signal switching device(s). The control unit is made up of the signal processing and output signal switching device(s). The pressure-sensitive protection device is triggered when the sensor is activated.

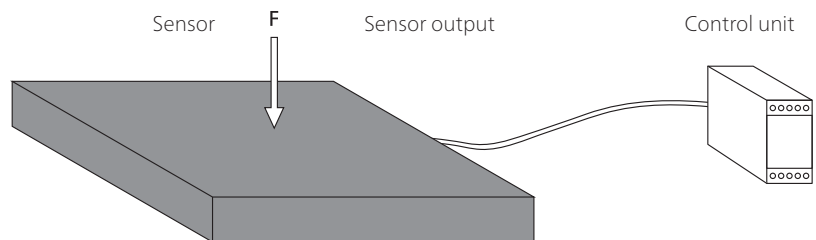

#### Sensor

The sensor is the part of the pressure-sensitive protection device that generates a signal when the actuating force  $F$  is applied. Mayser safety systems have a sensor whereby the actuating surface is deformed locally.

#### Signal processing

The signal processing is the part of the pressure-sensitive protection device that converts the output signal of the sensor and controls the status of the output signal switching device. The output signal switching device is that part of the signal processing which is connected to the machine controls and transmits safety output signals such as STOP.

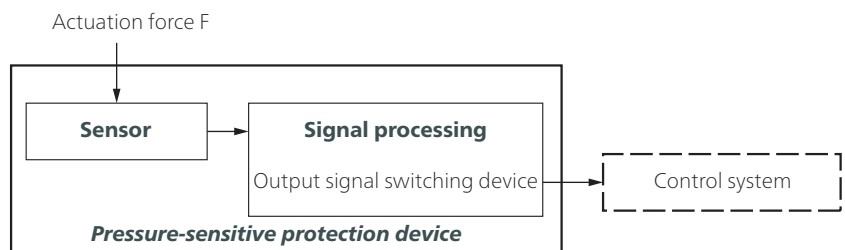

Tip: Terms are defined in ISO 13856-1, Chapter 3.



**Criteria for selecting the sensor type**

- Category according to ISO 13849-1
- Performance level of pressure-sensitive protection device = at least  $PL_r$
- Temperature range
- Degree of protection in accordance with IEC 60529:  
IP67 is the standard for safety edges.  
Higher degrees of protection must be checked individually.
- Environmental influences such as swarf, oil, coolant, outdoor use...
- Finger detection necessary?

**Operation principle 2-wire-technology**

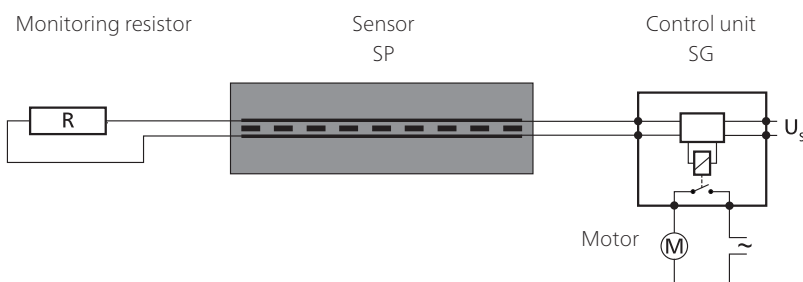

The monitoring resistor must be compatible with the control unit.  
Standard value is 8k2.

For your safety:

Sensor and connecting cables are constantly monitored for function.  
Monitoring is carried out by controlled bridging of the contact surfaces with a monitoring resistor (closed current principle).

**Design**

SP/BK with cables on both sides as a through sensor or as an end sensor with external monitoring resistor

SP/W as an end sensor with integrated monitoring resistor

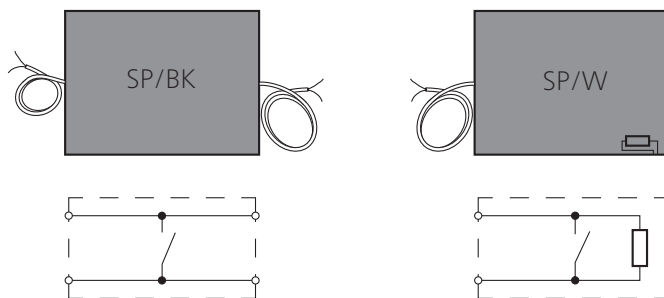

## Combination of sensors

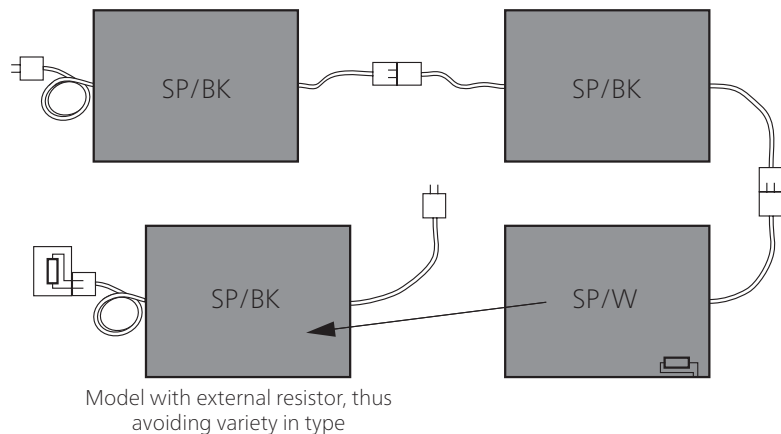

Combination:

- Connection of more than one sensor
- Only one control unit required
- Safety edge design with custom lengths and angles

## Operation principle 4-wire-technology

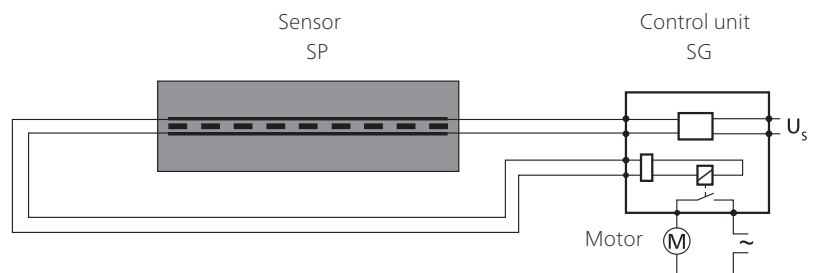

The 4-wire technology can be used only together with control unit SG-EFS 104/4L.

For your safety:

Sensor and connecting cables are constantly monitored for function. This is possible because of signal transmission feedback – without a monitoring resistor.

### Design

SP/BK with cables on both sides as a through sensor

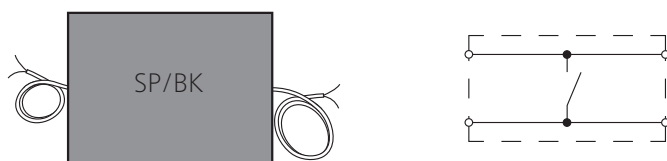

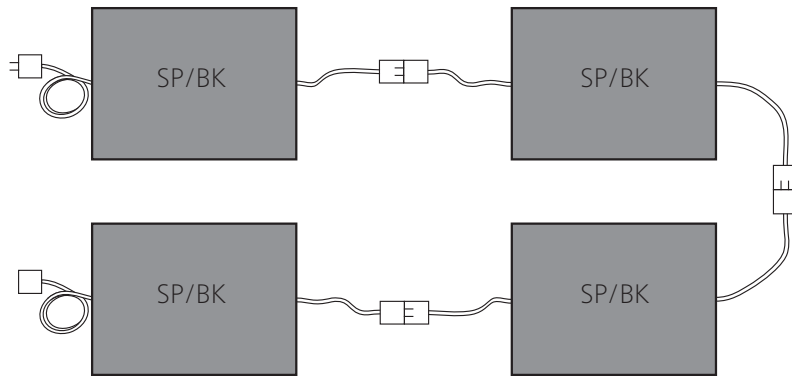
**Combination of sensors**

Combination:

- Connection of more than one sensor
- Only one control unit required
- Safety edge design with custom lengths and angles

## Safety

### Intended use

A safety edge detects a person or part of the body when pressure is applied to the actuation area. It is a linear tripping device. Its task is to avoid possible hazardous situations for a person within a danger zone, such as shearing and pinching edges.

Typical areas of application are door and gate systems, moving parts on machines, platforms and lifting devices.

Safe operation of a safety edge depends entirely on

- the surface condition of the mounting surface,
- the correct selection of the size and resistance as well as
- correct installation.

For additional application guidelines refer to ISO 13856-2 Annex E.

Due to the design, the visible actuation area is reduced by the non-sensitive edges. What remains is the actual effective actuation area (see chapter *Effective actuation area*).

### Limits

- max. 3 sensors type BK on one control unit
  - max. 2 sensors type BK and 1 sensor type W on one control unit
- If more sensors are required, please contact Mayser's service department.

### Exclusions

The sensors are not suitable for performing a sealing function. Constant actuation of sensors can result in permanent damage.

Exception: The L version with an attached edge seal.

The edge seal can be in full contact with the closing edge, which allows it to repel wind and water.

## Other safety aspects

The following safety aspects relate to pressure-sensitive protection devices consisting of a sensor and a control unit

### Performance Level (PL)

The PL was determined during a simplified procedure according to ISO 13849-1.

Fault exclusion according to ISO 13849-2 Table D.8: Non-closing of contact by pressure-sensitive equipment according to ISO 13856. In this case the sensor will no longer be taken into account in determining the PL. The entire pressure sensitive safety edge (Pressure-sensitive protection device) system can reach a maximum of PL d.

### Is the safeguard appropriate?

The PL required for the hazard must be decided by the integrator. This is followed by the choice of safeguard.

Finally, the integrator needs to check whether the category and PL of the safeguard chosen are appropriate.

### Risk and safety assessment

For the risk and safety assessment of your machine we recommend ISO 12100 „Safety of machinery – general principles for design“.

### Without reset function

When a safeguard without a reset function is used (automatic reset), the reset function must be made available in some other way.

## Design

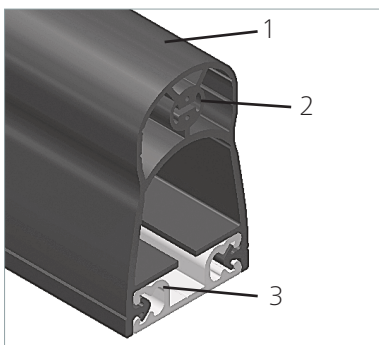

The normally open safety edge SP consists of  
one sensor (1 to 3)  
(1) Contact profile SP with  
(2) integrated normally open  
safety element,  
(3) Aluminium profile C 15, C 25  
or C 30

## Effective actuation area

The parameters X, Y, Z, L<sub>NE</sub> and the angle α describe the effective actuation area.

For the effective actuation area, the following applies:

$$L_{WB} = L_{SP} - 2 \times L_{NE}$$

Parameters:

L<sub>WB</sub> = effective actuation length

L<sub>SP</sub> = total length of sensor profile

L<sub>NE</sub> = non-sensitive length at end of sensor profile

α = effective actuation angle

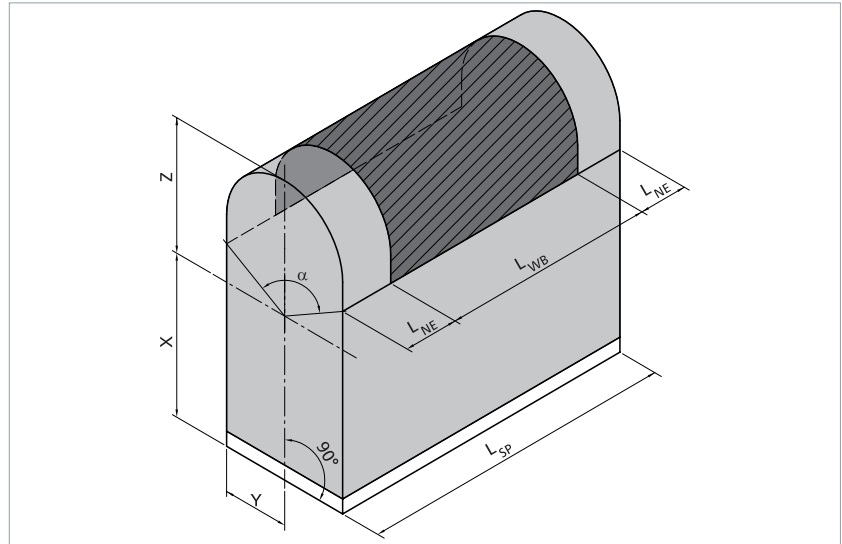

	SP 17-3 <sup>1)</sup>	SP 37-1 <sup>2)</sup>	SP 37-1 <sup>3)</sup>	SP 37-1 <sup>1)</sup>	SP 37-3 <sup>3)</sup>	SP 57-2 <sup>3)</sup>	SP 57L-2 <sup>3)</sup>	SP 57-3 <sup>3)</sup>	SP 67-2 <sup>3)</sup>
α	90°	100°	100°	100°	100°	90°	90°	90°	90°
L <sub>NE</sub>	60 mm	60 mm	20 mm	20 mm	20 mm	10 mm <sup>4)</sup>	10 mm <sup>4)</sup>	10 mm <sup>4)</sup>	20 mm <sup>4)</sup>
X	7.3 mm	28 mm <sup>5)</sup>	28 mm <sup>5)</sup>	28 mm <sup>5)</sup>	28 mm <sup>5)</sup>	44 mm	44 mm	52 mm <sup>6)</sup>	57.3 mm
Y	6.7 mm	12.5 mm	12.5 mm	12.5 mm	12.5 mm	17 mm	17 mm	17.5 mm	17 mm
Z	5 mm	9 mm	9 mm	9 mm	9 mm	12 mm	12 mm <sup>7)</sup>	12 mm	10 mm

<sup>1)</sup> without end cap

<sup>2)</sup> with hard end cap

<sup>3)</sup> with soft end cap

<sup>4)</sup> with finger protection

<sup>5)</sup> including aluminium profile C 25

<sup>6)</sup> including aluminium profile C 35

<sup>7)</sup> without lip

## Installation position

The installation position can be selected as required, i.e. all installation positions A to D as per ISO 13856-2 are possible.

Subject to technical modifications.

## Connection

### Cable exits

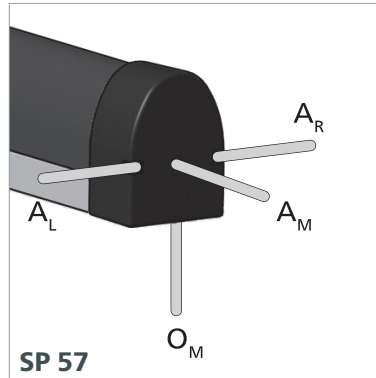
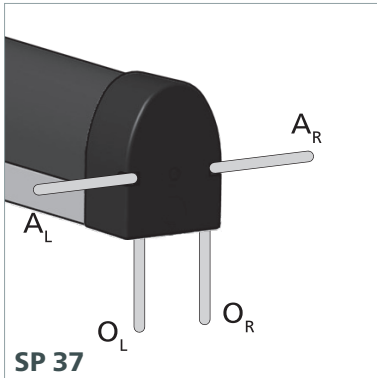

Depending on the end cap, there are 6 possible cable exits.

- A = axial
- O = orthogonal
- L = left
- M = middle
- R = right

### Cable connection

- Standard cable lengths  
L = 2,5 m
- Maximum total cable length to the control unit  
L<sub>max</sub> = 100 m

#### Sensor type W

- As an individual sensor type W or an end sensor type W
- Integrated resistor
- 2-wire cable (Ø 2.9 mm PUR, 2x 0.25 mm<sup>2</sup> Cu)

#### Sensor type BK with 2 lines

- As a feed-through sensor type BK
- Without resistor
- 2 two-wire cables (Ø 2.9 mm PUR, 2x 0.25 mm<sup>2</sup> Cu)

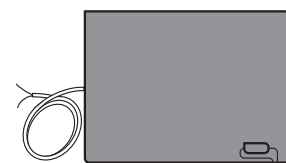

## Wire colours

### Colour coding

- BK Black
- RD Red

### Sensor type W

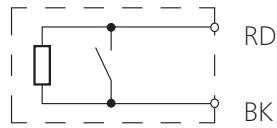

### Sensor type BK with 2 lines

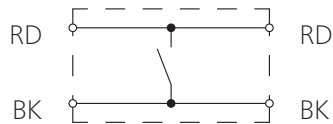

## Sensor surface

### Physical resistance

Sensor profile SP	TPE
IEC 60529: Degree of protection UV-resistance	IP67 yes

### Chemical resistance

The sensor is resistant against normal chemical influences such as diluted acids and alkalis as well as alcohol over an exposure period of 24 hrs.

The specifications in the table are the result of tests conducted in our lab at room temperature (+23 °C). The suitability of our products for your special area of application must always be verified with your own practical tests.

*Subject to technical modifications.*



Material	TPE
Acetone	-
Formic acid	-
Armor All	+
Car shampoo	+
Petrol	-
Brake fluid	+
Buraton	+
Butanol	-
Sodium hypochlorite	-
Disinfectant 1 %	+
Diesel	-
Acetic acid 10 %	-
Ethanol	+
Ethyl acetate	-
Ethylene glycol	+
Greases	±
Anti-frost agent	+
Skin cream	+
Icidine	+
Incidine	+
Incidine plus	+
Cooling lubricant	-
Plastic cleaner	+
Lyso FD 10	+
Metal working oil	-
Microbac	+
Microbac forte	+
Minutil	+
Saline solution 5 %	+
White spirit (ethyl alcohol)	+
Terralin	+
Centring oil	-

**Explanation of symbols:**

+ = resistant

± = resistant to a certain extent

- = not resistant

## Attachment

Sensor Profiles SP are mounted directly onto the main and secondary closing edges that present a danger. They are mounted using the aluminium profile C 15, the aluminium profiles from the C 25 aluminium profile range and also the C 30 aluminium profile. Mount the aluminium profiles with M5 screws or rivets.

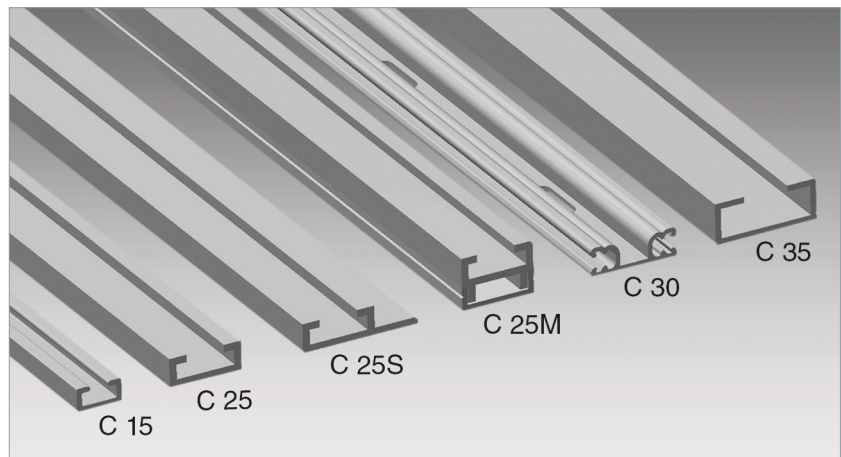



### Material properties

- AlMgSi0.5 F22
- wall thickness at least 2.0 mm  
C 30: at least 1.5 mm  
C 15: mind. 1.7 mm
- hot hardened
- extruded
- tolerances as per EN 755-9

## Aluminium profiles:

### Overview of combinations

Aluminium profiles for		SP 17-3	SP 37-1	SP 37-3	SP 57-2	SP 57L-2	SP 57-3	SP 67-2
Snap-in foot (middle)	...-1 	–	C 25, C 25S, C 25M	–	–	–	–	–
Clip bar (outside)	...-2 	–	–	–	C 30	C 30	–	C 30
T-foot (middle)	...-3 	C 15	–	C 25, C 25S, C 25M	–	–	C 35	–

*Subject to technical modifications.*

## Aluminium profile C 15

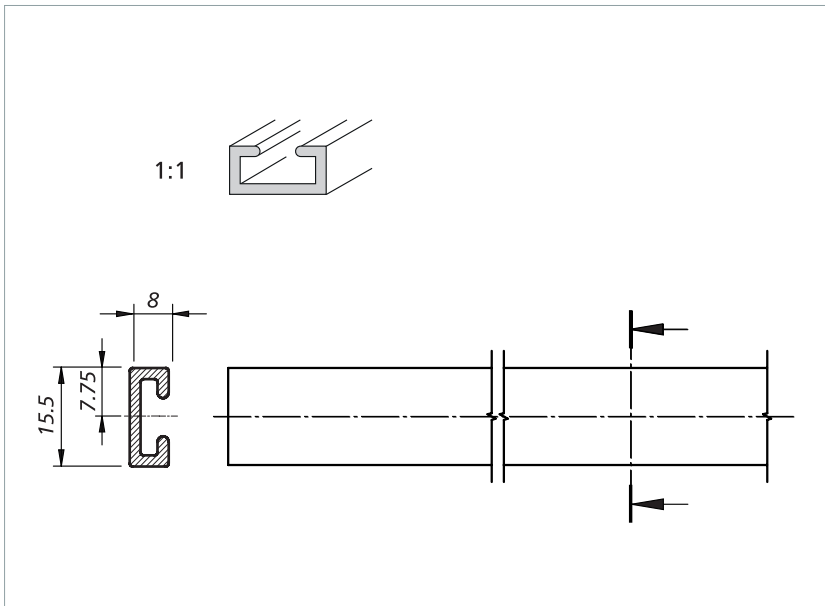

Standard profile for SP 17-3:

First the aluminium profile must be mounted onto the closing edge and then the sensor profile clipped into the aluminium profile.

## Aluminium profile C 25

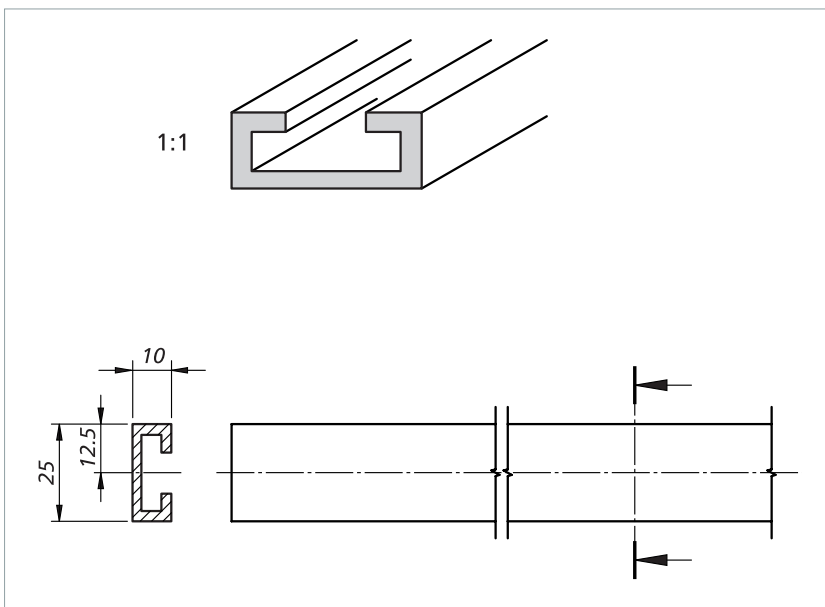

Standard profile for SP 37-1 and SP 37-3:

First the aluminium profile must be mounted onto the closing edge and then the sensor profile clipped into the aluminium profile.

## Aluminium profile C 25S

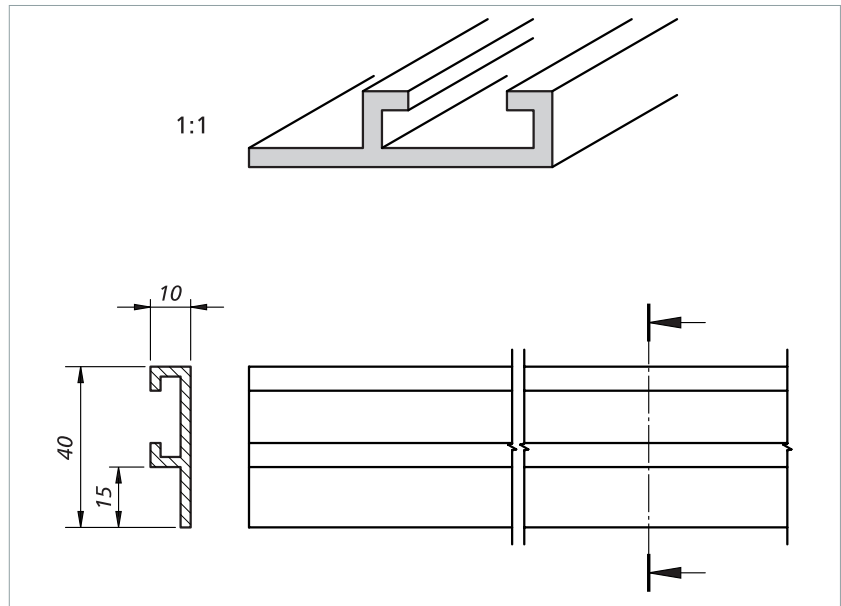

Flange profile for SP 37-1 and SP 37-3:

Final assembly is also possible when the sensor profile is already clipped into the aluminium profile.

Due to the flange, **no hard end caps** can be installed here. Soft end caps must be cut in.

## Aluminium profile C 25M

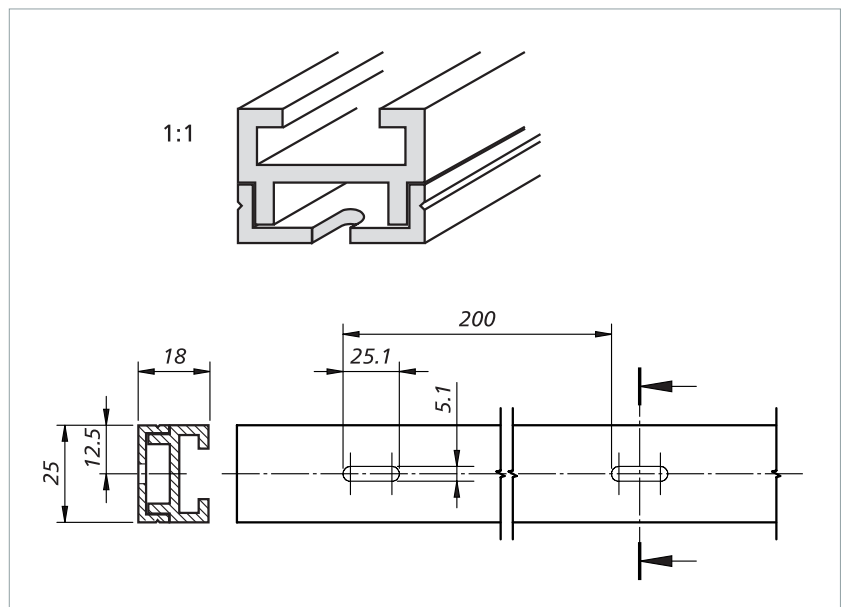

Two-part profile for SP 37-1 and SP 37-3:

For convenient assembly and disassembly. The sensor profile is clipped into the upper section and the upper section inserted into the installed lower section and fastened.

*Subject to technical modifications.*

## Aluminium profile C 30

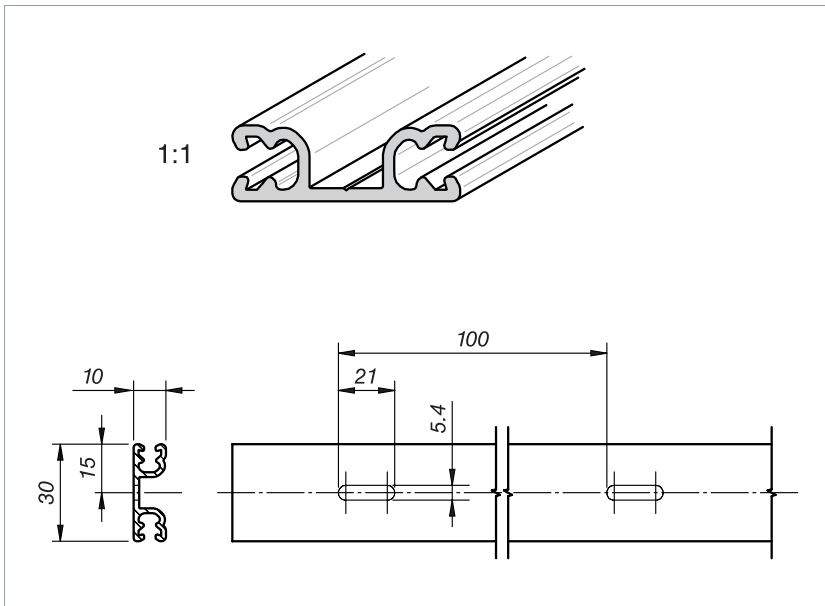

Standard profile for SP 57(L)-2 and SP 67-2:

First the aluminium profile must be mounted onto the closing edge and then the sensor profile clipped into the aluminium profile.

## Aluminium profile C 35

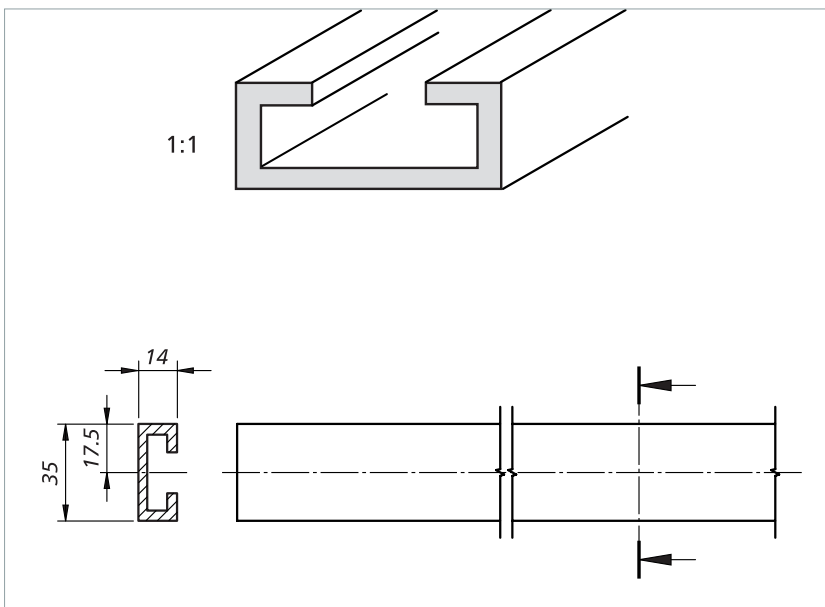

Standard profile for SP 57-3:

First the aluminium profile must be mounted onto the closing edge and then the sensor profile clipped into the aluminium profile.

## Maintenance and cleaning

The sensors are virtually maintenance-free.  
The control unit also monitors the sensor.

### Regular inspection

Depending on the utilisation, sensors must be inspected at regular intervals (at least monthly)

- for proper functioning,
- damage,
- and correct mounting.

### Cleaning

If the sensors become dirty, they can be cleaned with a mild cleaning product.

## Technical data

### SK SP 17-3 TPE

Sensor profile SP manufactured without end caps.

Sensor profile (without sensor)	SK SP/W 17-3 TPE or SK SP/BK 17-3 TPE
Test principles	EN 12978, ISO 13849-1, ISO 13856-2
<b>Switching characteristics at <math>v_{test} = 10 \text{ mm/s}</math></b>	
Switching operations	10,000
Actuation force	
Test piece Ø 20 mm	< 50 N
Test piece (cylinder) Ø 80 mm	< 150 N
Actuation distance	
Test piece (cylinder) Ø 80 mm	1.5 mm
Actuation angle	
Test piece (cylinder) Ø 80 mm	±45°
Finger detection	yes
<b>Safety classifications</b>	
ISO 13849-1: $B_{10D}$	$2 \times 10^6$
<b>Mechanical operating conditions</b>	
Sensor length (min./max.)	10 cm / 80 m
Cable length (min./max.)	10 cm / 200 m
Bend radii, minimal	
$B_1 / B_2 / B_3 / B_4$	200 / 200 / 50 / 50 mm
Operating speed	
(min. / max.)	10 mm/s / 10 mm/s
Tensile load, cable (max.)	600 N
IEC 60529: Degree of protection	IP67
Operating temperature	
short-term (15 min)	-25 to +55 °C
Storage temperature	-40 to +80 °C
Weight (without/with aluminium profile)	0.12 / 0.26 kg/m
<b>Electrical operating conditions</b>	
Terminal resistance	$8k2 \pm 1 \%$
Rated capacity (max.)	250 mW
Contact transition resistance	< 400 Ohm (per sensor)
Number of sensors type BK	max. 3 in series (for more information refer to the chapter <i>Limits</i> )
Switching voltage (max.)	DC 24 V
Switching current (min. / max.)	1 mA / 10 mA
Connection cable	Ø 2.9 mm PUR 2x 0.25 mm <sup>2</sup>
<b>Dimensional tolerances</b>	
Length according to	ISO 3302 L2
Profile section according to	ISO 3302 E2

Bend radii:

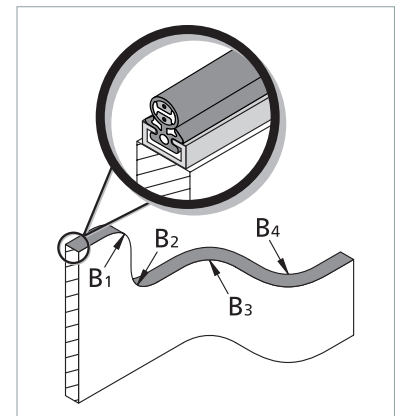

## Dimensions and distances

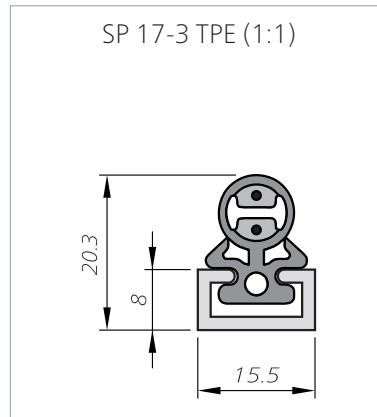

Dimensional tolerances according to ISO 3302 E2/L2.

### Test conditions

according to ISO 13856-2

- Installation position B
- Temperature +20 °C
- Measurement point c3
- Test sample 1 with Ø 80 mm
- without control unit

All the data given here has been verified by Mayser GmbH & Co. KG.

### Force-distance ratios

Actuation force	38 N
Response time	140 ms
Actuation distance (A)	1.4 mm
Overtravel distance	
up to 250 N (B1)	1.4 mm
up to 400 N (B2)	2.3 mm
up to 600 N (C)	4.1 mm
Total deformation	5.5 mm

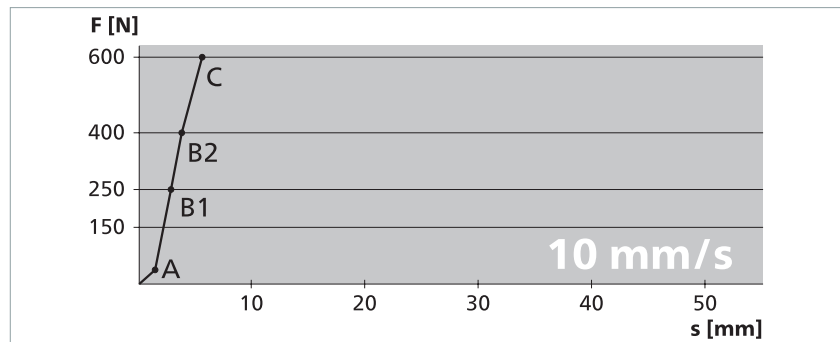



## Technical data

### SK SP 37-1 TPE

Sensor profile SP manufactured with or without end caps

Sensor profile (without sensor)	SK SP/W 37-1 TPE or SK SP/BK 37-1 TPE
Test principles	EN 12978, ISO 13849-1, ISO 13856-2
<b>Switching characteristics at <math>v_{test} = 100 \text{ mm/s}</math></b>	
Switching operations	10,000
Actuation force	
Test piece $\varnothing 20 \text{ mm}$	< 50 N
Test piece (cylinder) $\varnothing 80 \text{ mm}$	< 150 N
Actuation distance	
Test piece (cylinder) $\varnothing 80 \text{ mm}$	6 mm
Actuation angle	
Test piece (cylinder) $\varnothing 80 \text{ mm}$	$\pm 50^\circ$
Finger detection	yes
<b>Safety classifications</b>	
ISO 13849-1: $B_{10D}$	$2 \times 10^6$
<b>Mechanical operating conditions</b>	
Sensor length (min./max.)	10 cm / 30 m
Cable length (min./max.)	10 cm / 200 m
Bend radii, minimal	
$B_1 / B_2 / B_3 / B_4$	500 / 500 / 200 / 200 mm
Operating speed	
(min. / max.)	10 mm/s / 200 mm/s
Tensile load, cable (max.)	600 N
IEC 60529: Degree of protection	IP67
Operating temperature	
short-term (15 min)	-25 to +55 °C
Storage temperature	-40 to +80 °C
Weight (without/with aluminium profile)	0.32 / 0.62 kg/m
<b>Electrical operating conditions</b>	
Terminal resistance	$8k2 \pm 1 \%$
Rated capacity (max.)	250 mW
Contact transition resistance	< 400 Ohm (per sensor)
Number of sensors type BK	max. 3 in series (for more information refer to the chapter <i>Limits</i> )
Switching voltage (max.)	DC 24 V
Switching current (min. / max.)	1 mA / 10 mA
Connection cable	$\varnothing 2.9 \text{ mm PUR } 2 \times 0.25 \text{ mm}^2$
<b>Dimensional tolerances</b>	
Length according to	ISO 3302 L2
Profile section according to	ISO 3302 E2

Bend radii:

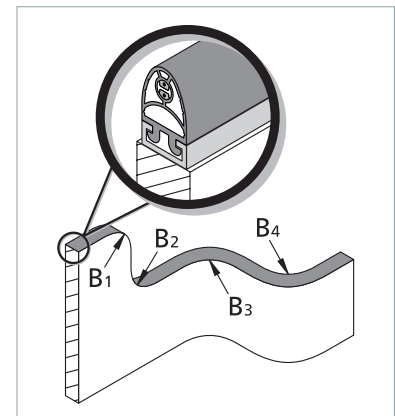

## Dimensions and distances

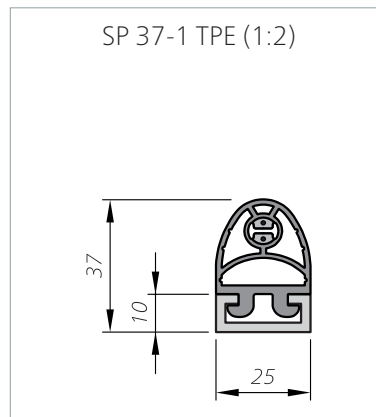

Dimensional tolerances according to ISO 3302 E2/L2.

### Test conditions

according to ISO 13856-2

- Installation position B
- Temperature +20 °C
- Measurement point c3
- Test sample 1 with Ø 80 mm
- without control unit

All data stated here is documented in EC design type test certificates.

### Force-distance ratios

Actuation force	42 N
Response time	580 ms
Actuation distance (A)	5.8 mm
Overtravel distance	
up to 250 N (B1)	9.2 mm
up to 400 N (B2)	11.1 mm
up to 600 N (C)	13.0 mm
Total deformation	18.8 mm

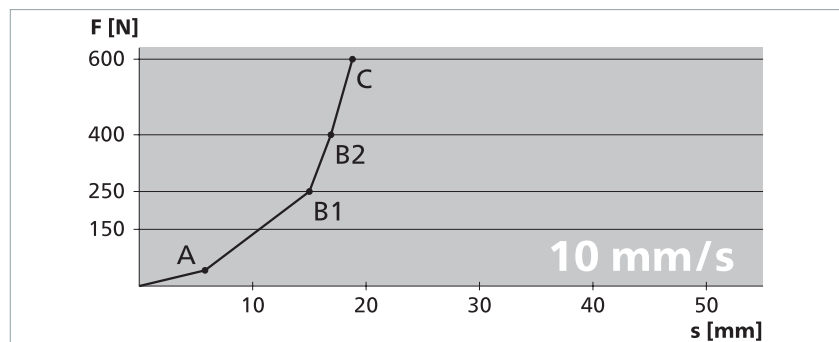

Actuation force	50 N
Response time	58 ms
Actuation distance (A)	5.8 mm
Overtravel distance	
up to 250 N (B1)	8.7 mm
up to 400 N (B2)	10.5 mm
up to 600 N (C)	12.5 mm
Total deformation	18.3 mm

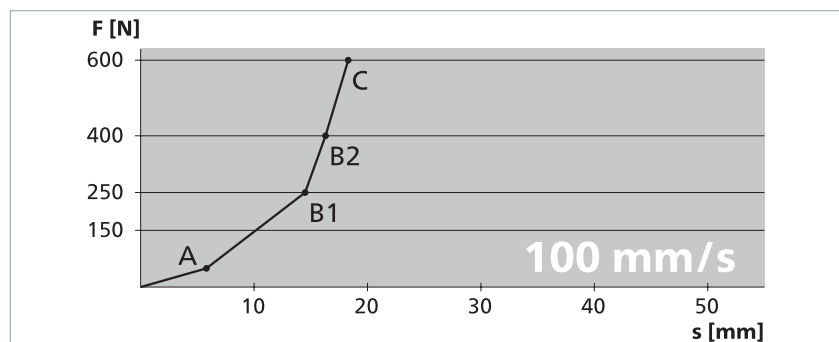

Actuation force	54 N
Response time	35 ms
Actuation distance (A)	7.0 mm
Overtravel distance	
up to 250 N (B1)	3.8 mm
up to 400 N (B2)	7.6 mm
up to 600 N (C)	12.9 mm
Total deformation	19.9 mm

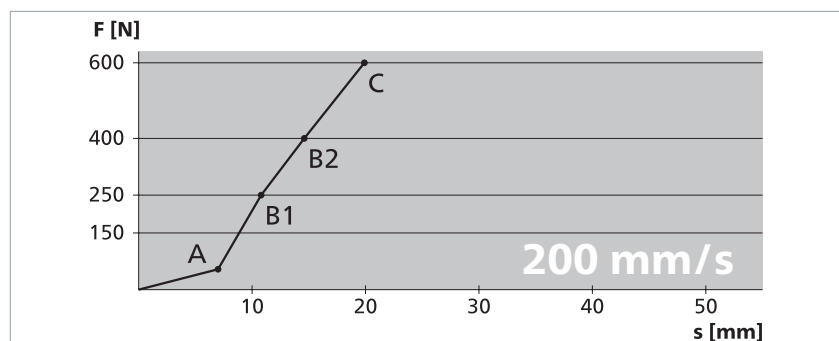

## Technical data

### SK SP 37-3 TPE

Sensor profile SP manufactured with end caps.

Sensor profile (without sensor)	SK SP/W 37-3 TPE or SK SP/BK 37-3 TPE
Test principles	EN 12978, ISO 13849-1, ISO 13856-2
<b>Switching characteristics at <math>v_{test} = 100 \text{ mm/s}</math></b>	
Switching operations	10,000
Actuation force	
Test piece $\varnothing 20 \text{ mm}$	< 50 N
Test piece (cylinder) $\varnothing 80 \text{ mm}$	< 150 N
Actuation distance	
Test piece (cylinder) $\varnothing 80 \text{ mm}$	6 mm
Actuation angle	
Test piece (cylinder) $\varnothing 80 \text{ mm}$	$\pm 50^\circ$
Finger detection	yes
<b>Safety classifications</b>	
ISO 13849-1: $B_{10D}$	$2 \times 10^6$
<b>Mechanical operating conditions</b>	
Sensor length (min./max.)	10 cm / 30 m
Cable length (min./max.)	10 cm / 200 m
Bend radii, minimal	
$B_1 / B_2 / B_3 / B_4$	500 / 500 / 200 / 200 mm
Operating speed (min. / max.)	10 mm/s / 200 mm/s
Tensile load, cable (max.)	600 N
IEC 60529: Degree of protection	IP67
Operating temperature	-25 to +55 °C
short-term (15 min)	-40 to +80 °C
Storage temperature	-40 to +80 °C
Weight (without/with aluminium profile)	0.32 / 0.62 kg/m
<b>Electrical operating conditions</b>	
Terminal resistance	$8k2 \pm 1 \%$
Rated capacity (max.)	250 mW
Contact transition resistance	< 400 Ohm (per sensor)
Number of sensors type BK	max. 3 in series (for more information refer to the chapter <i>Limits</i> )
Switching voltage (max.)	DC 24 V
Switching current (min. / max.)	1 mA / 10 mA
Connection cable	$\varnothing 2.9 \text{ mm PUR } 2 \times 0.25 \text{ mm}^2$
<b>Dimensional tolerances</b>	
Length according to	ISO 3302 L2
Profile section according to	ISO 3302 E2

Bend radii:

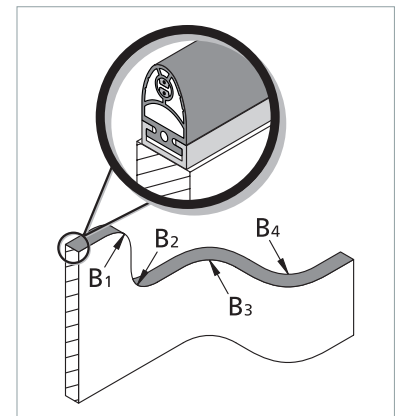

## Dimensions and distances

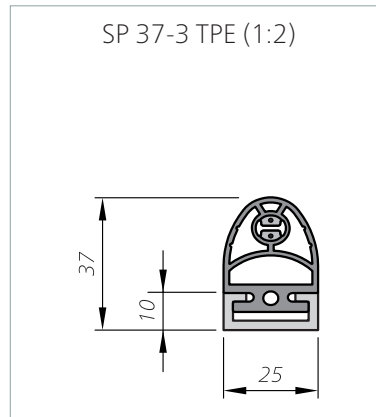

Dimensional tolerances according to ISO 3302 E2/L2.

### Test conditions

according to ISO 13856-2

- Installation position B
- Temperature +20 °C
- Measurement point c3
- Test sample 1 with Ø 80 mm
- without control unit

All data stated here is documented in EC design type test certificates.

### Force-distance ratios

Actuation force	42 N
Response time	580 ms
Actuation distance (A)	5.8 mm
Overtravel distance	
up to 250 N (B1)	9.2 mm
up to 400 N (B2)	11.1 mm
up to 600 N (C)	13.0 mm
Total deformation	18.8 mm

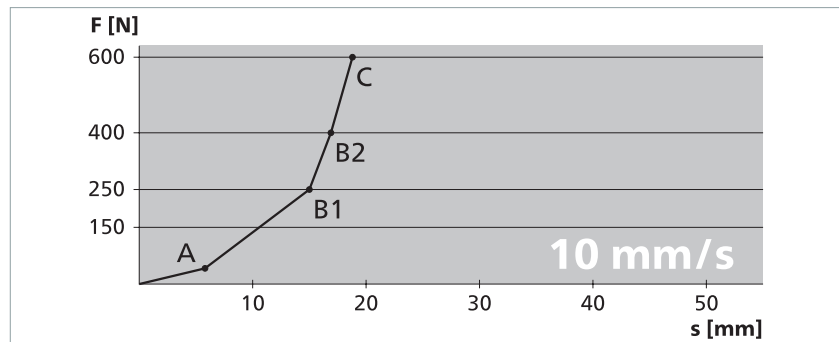

Actuation force	50 N
Response time	58 ms
Actuation distance (A)	5.8 mm
Overtravel distance	
up to 250 N (B1)	8.7 mm
up to 400 N (B2)	10.5 mm
up to 600 N (C)	12.5 mm
Total deformation	18.3 mm

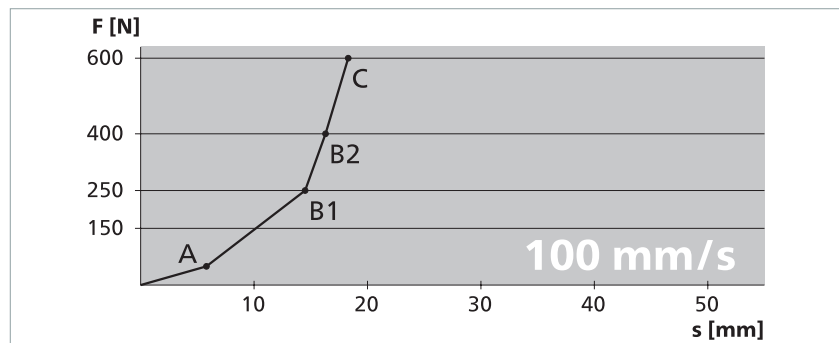

Actuation force	54 N
Response time	35 ms
Actuation distance (A)	7.0 mm
Overtravel distance	
up to 250 N (B1)	3.8 mm
up to 400 N (B2)	7.6 mm
up to 600 N (C)	12.9 mm
Total deformation	19.9 mm

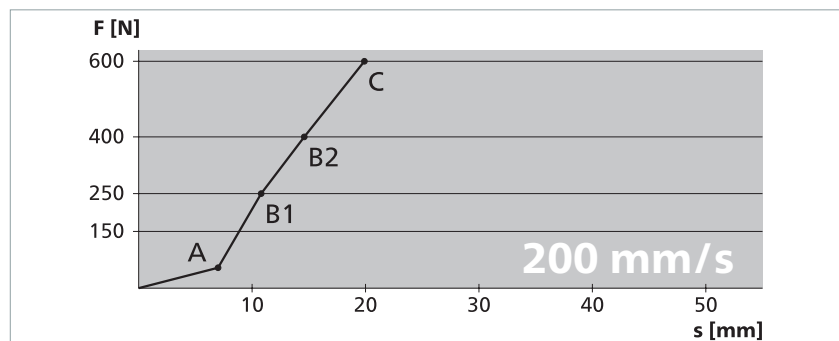

## Technical data

### SK SP 57-2 TPE

Sensor profile SP manufactured with end caps.

Sensor profile (without sensor)	SK SP/W 57-2 TPE or SK SP/BK 57-2 TPE
Test principles	EN 12978, ISO 13849-1, ISO 13856-2
<b>Switching characteristics at <math>v_{test} = 100 \text{ mm/s}</math></b>	
Switching operations	10,000
Actuation force	
Test piece Ø 20 mm	< 50 N
Test piece (cylinder) Ø 80 mm	< 150 N
Actuation distance	
Test piece (cylinder) Ø 80 mm	8 mm
Actuation angle	
Test piece (cylinder) Ø 80 mm	±45°
Finger detection	yes
<b>Safety classifications</b>	
ISO 13849-1: $B_{10D}$	$2 \times 10^6$
<b>Mechanical operating conditions</b>	
Sensor length (min./max.)	10 cm / 30 m
Cable length (min./max.)	10 cm / 200 m
Bend radii, minimal	
$B_1 / B_2 / B_3 / B_4$	1000 / 1000 / 200 / 200 mm
Operating speed (min. / max.)	10 mm/s / 200 mm/s
Tensile load, cable (max.)	600 N
IEC 60529: Degree of protection	IP67
Operating temperature	-25 to +55 °C
short-term (15 min)	-40 to +80 °C
Storage temperature	-40 to +80 °C
Weight (without/with aluminium profile)	0.40 / 0.70 kg/m
<b>Electrical operating conditions</b>	
Terminal resistance	$8k2 \pm 1 \%$
Rated capacity (max.)	250 mW
Contact transition resistance	< 400 Ohm (per sensor)
Number of sensors type BK	max. 3 in series (for more information refer to the chapter <i>Limits</i> )
Switching voltage (max.)	DC 24 V
Switching current (min. / max.)	1 mA / 10 mA
Connection cable	Ø 2.9 mm PUR 2x 0.25 mm <sup>2</sup>
<b>Dimensional tolerances</b>	
Length according to	ISO 3302 L2
Profile section according to	ISO 3302 E2

Bend radii:

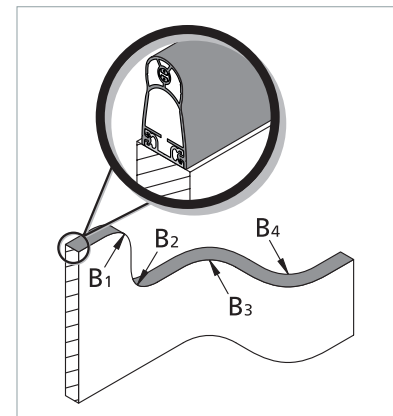

## Dimensions and distances

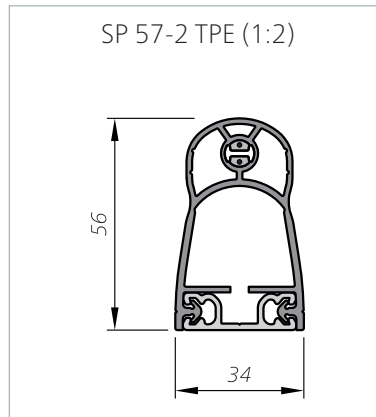

Dimensional tolerances according to ISO 3302 E2/L2.

### Test conditions

according to ISO 13856-2

- Installation position B
- Temperature +20 °C
- Measurement point c3
- Test sample 1 with Ø 80 mm
- without control unit

All data stated here is documented in EC design type test certificates.

### Force-distance ratios

Actuation force	48 N
Response time	910 ms
Actuation distance (A)	9.1 mm
Overtravel distance	
up to 250 N (B1)	24.5 mm
up to 400 N (B2)	29.3 mm
up to 600 N (C)	31.0 mm
Total deformation	40.1 mm

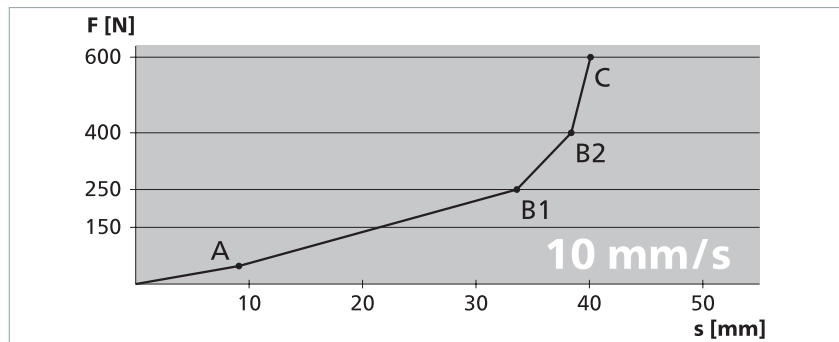

Actuation force	41 N
Response time	80 ms
Actuation distance (A)	8.0 mm
Overtravel distance	
up to 250 N (B1)	26.0 mm
up to 400 N (B2)	29.4 mm
up to 600 N (C)	31.5 mm
Total deformation	39.5 mm

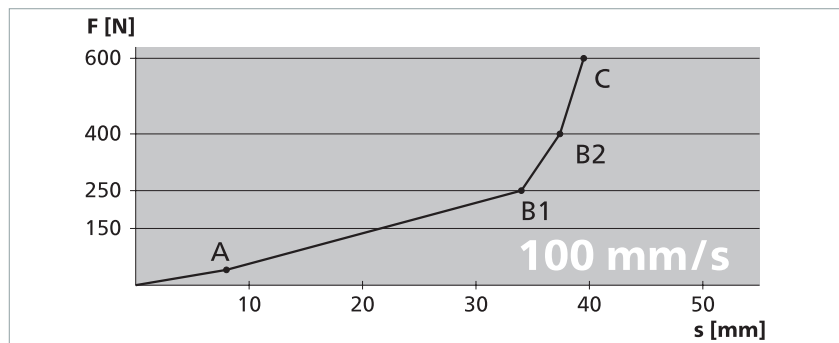

Actuation force	58 N
Response time	71 ms
Actuation distance (A)	14.2 mm
Overtravel distance	
up to 250 N (B1)	20.8 mm
up to 400 N (B2)	23.7 mm
up to 600 N (C)	25.9 mm
Total deformation	40.1 mm

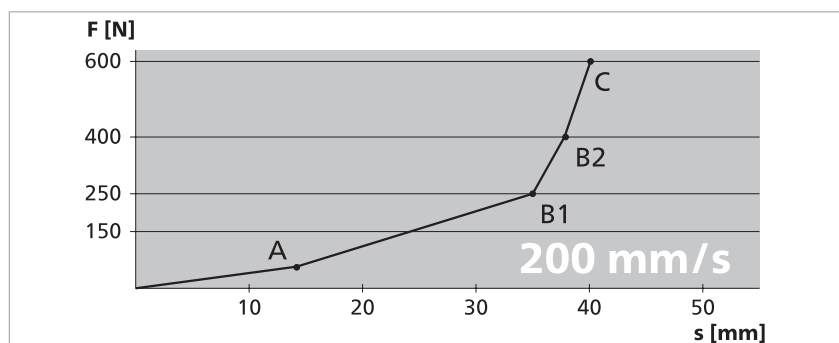

## Technical data

### SK SP 57L-2 TPE

Sensor profile SP manufactured with end caps.

Sensor profile (without sensor)	SK SP/W 57L-2 TPE or SK SP/BK 57L-2 TPE
Test principles	EN 12978, ISO 13849-1, ISO 13856-2
<b>Switching characteristics at <math>v_{test} = 100 \text{ mm/s}</math></b>	
Switching operations	10,000
Actuation force	
Test piece $\varnothing 20 \text{ mm}$	< 50 N
Test piece (cylinder) $\varnothing 80 \text{ mm}$	< 150 N
Actuation distance	
Test piece (cylinder) $\varnothing 80 \text{ mm}$	8 mm
Actuation angle	
Test piece (cylinder) $\varnothing 80 \text{ mm}$	$\pm 45^\circ$
Finger detection	yes
<b>Safety classifications</b>	
ISO 13849-1: $B_{10D}$	$2 \times 10^6$
<b>Mechanical operating conditions</b>	
Sensor length (min./max.)	10 cm / 30 m
Cable length (min./max.)	10 cm / 200 m
Bend radii, minimal	
$B_1 / B_2 / B_3 / B_4$	1000 / 1000 / 200 / 200 mm
Operating speed (min. / max.)	10 mm/s / 200 mm/s
Tensile load, cable (max.)	600 N
IEC 60529: Degree of protection	IP67
Operating temperature short-term (15 min)	-25 to +55 °C -40 to +80 °C
Storage temperature	-40 to +80 °C
Weight (without/with aluminium profile)	0.45 / 0.75 kg/m
<b>Electrical operating conditions</b>	
Terminal resistance	$8k2 \pm 1 \%$
Rated capacity (max.)	250 mW
Contact transition resistance	< 400 Ohm (per sensor)
Number of sensors type BK	max. 3 in series (for more information refer to the chapter <i>Limits</i> )
Switching voltage (max.)	DC 24 V
Switching current (min. / max.)	1 mA / 10 mA
Connection cable	$\varnothing 2.9 \text{ mm PUR } 2 \times 0.25 \text{ mm}^2$
<b>Dimensional tolerances</b>	
Length according to	ISO 3302 L2
Profile section according to	ISO 3302 E2

Bend radii:

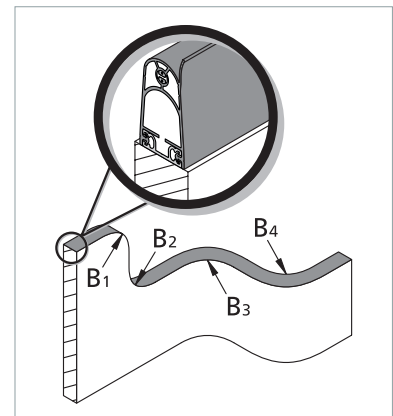

## Dimensions and distances

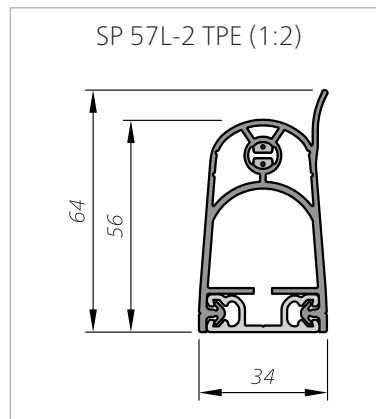

Dimensional tolerances according to ISO 3302 E2/L2.

### Test conditions

according to ISO 13856-2

- Installation position B
- Temperature +20 °C
- Measurement point c3
- Test sample 1 with Ø 80 mm
- without control unit
- Lip not taken into account

All data stated here is documented in EC design type test certificates.

### Force-distance ratios

Actuation force	48 N
Response time	910 ms
Actuation distance (A)	9.1 mm
Overtravel distance	
up to 250 N (B1)	24.5 mm
up to 400 N (B2)	29.3 mm
up to 600 N (C)	31.0 mm
Total deformation	40.1 mm

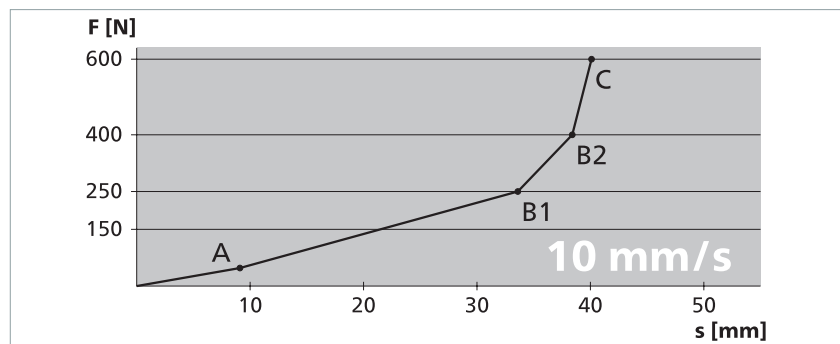

Actuation force	41 N
Response time	80 ms
Actuation distance (A)	8.0 mm
Overtravel distance	
up to 250 N (B1)	26.0 mm
up to 400 N (B2)	29.4 mm
up to 600 N (C)	31.5 mm
Total deformation	39.5 mm

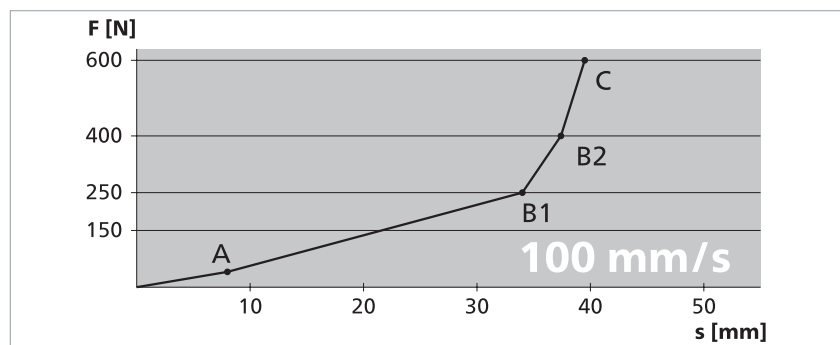

Actuation force	58 N
Response time	71 ms
Actuation distance (A)	14.2 mm
Overtravel distance	
up to 250 N (B1)	20.8 mm
up to 400 N (B2)	23.7 mm
up to 600 N (C)	25.9 mm
Total deformation	40.1 mm

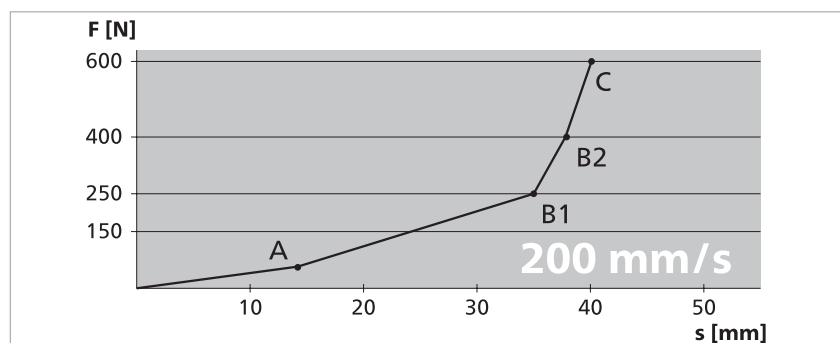



## Technical data

### SK SP 57-3 TPE

Sensor profile SP manufactured with end caps.

Sensor profile (without sensor)	SK SP/W 57-3 TPE or SK SP/BK 57-3 TPE
Test principles	EN 12978, ISO 13849-1, ISO 13856-2
<b>Switching characteristics at <math>v_{test} = 100 \text{ mm/s}</math></b>	
Switching operations	10,000
Actuation force	
Test piece Ø 20 mm	< 50 N
Test piece (cylinder) Ø 80 mm	< 150 N
Actuation distance	
Test piece (cylinder) Ø 80 mm	8 mm
Actuation angle	
Test piece (cylinder) Ø 80 mm	±45°
Finger detection	yes
<b>Safety classifications</b>	
ISO 13849-1: B <sub>10D</sub>	2 × 10 <sup>6</sup>
<b>Mechanical operating conditions</b>	
Sensor length (min./max.)	10 cm / 25 m
Cable length (min./max.)	10 cm / 200 m
Bend radii, minimal	
B <sub>1</sub> / B <sub>2</sub> / B <sub>3</sub> / B <sub>4</sub>	1000 / 1000 / 200 / 200 mm
Operating speed (min. / max.)	10 mm/s / 200 mm/s
Tensile load, cable (max.)	600 N
IEC 60529: Degree of protection	IP67
Operating temperature	-25 to +55 °C
short-term (15 min)	-40 to +80 °C
Storage temperature	-40 to +80 °C
Weight (without/with aluminium profile)	0.53 / 0.93 kg/m
<b>Electrical operating conditions</b>	
Terminal resistance	8k2 ± 1 %
Rated capacity (max.)	250 mW
Contact transition resistance	< 400 Ohm (per sensor)
Number of sensors type BK	max. 3 in series (for more information refer to the chapter <i>Limits</i> )
Switching voltage (max.)	DC 24 V
Switching current (min. / max.)	1 mA / 10 mA
Connection cable	Ø 2.9 mm PUR 2 × 0.25 mm <sup>2</sup>
<b>Dimensional tolerances</b>	
Length according to	ISO 3302 L2
Profile section according to	ISO 3302 E2

Bend radii:

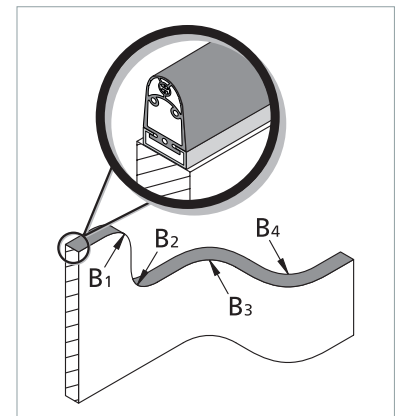

## Dimensions and distances

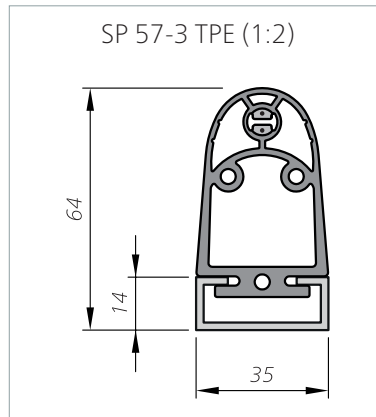

Dimensional tolerances according to ISO 3302 E2/L2.

### Test conditions

according to ISO 13856-2

- Installation position B
- Temperature +20 °C
- Measurement point c3
- Test sample 1 with Ø 80 mm
- without control unit

All data stated here is documented in EC design type test certificates.

### Force-distance ratios

Actuation force	48 N
Response time	910 ms
Actuation distance (A)	9.1 mm
Overtravel distance	
up to 250 N (B1)	24.5 mm
up to 400 N (B2)	29.3 mm
up to 600 N (C)	31.0 mm
Total deformation	40.1 mm

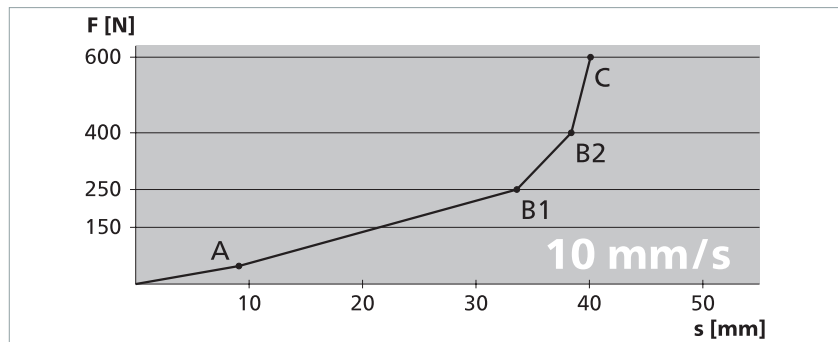

Actuation force	41 N
Response time	80 ms
Actuation distance (A)	8.0 mm
Overtravel distance	
up to 250 N (B1)	26.0 mm
up to 400 N (B2)	29.4 mm
up to 600 N (C)	31.5 mm
Total deformation	39.5 mm

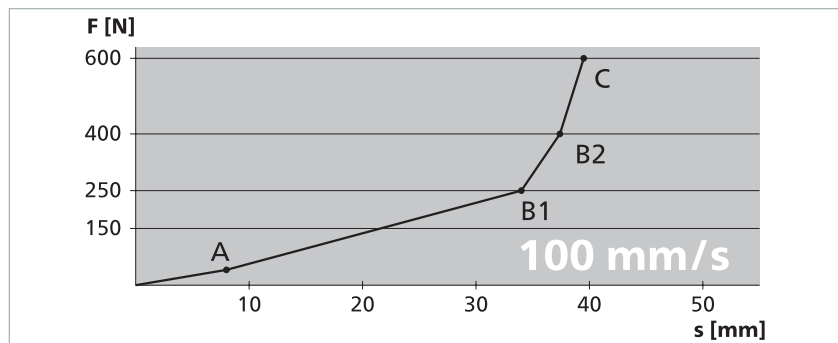

Actuation force	58 N
Response time	71 ms
Actuation distance (A)	14.2 mm
Overtravel distance	
up to 250 N (B1)	20.8 mm
up to 400 N (B2)	23.7 mm
up to 600 N (C)	25.9 mm
Total deformation	40.1 mm

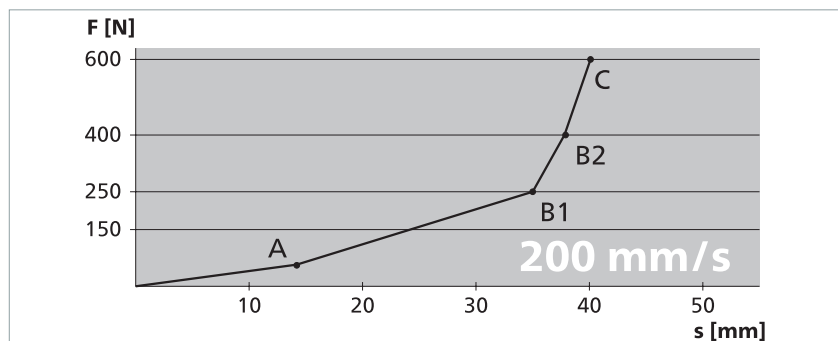

## Technical data

### SK SP 67-2 TPE

Sensor profile SP manufactured with end caps.

Sensor profile (without sensor)	SK SP/W 67-2 TPE or SK SP/BK 67-2 TPE
Test principles	EN 12978, ISO 13849-1, ISO 13856-2
<b>Switching characteristics at <math>v_{test} = 100 \text{ mm/s}</math></b>	
Switching operations	10,000
Actuation force	
Test piece $\varnothing 20 \text{ mm}$	< 50 N
Test piece (cylinder) $\varnothing 80 \text{ mm}$	< 150 N
Actuation distance	
Test piece (cylinder) $\varnothing 80 \text{ mm}$	11 mm
Actuation angle	
Test piece (cylinder) $\varnothing 80 \text{ mm}$	$\pm 50^\circ$
Finger detection	yes
<b>Safety classifications</b>	
ISO 13849-1: $B_{10D}$	$2 \times 10^6$
<b>Mechanical operating conditions</b>	
Sensor length (min./max.)	10 cm / 30 m
Cable length (min./max.)	10 cm / 200 m
Bend radii, minimal	
$B_1 / B_2 / B_3 / B_4$	1000 / 1000 / 200 / 200 mm
Operating speed (min. / max.)	10 mm/s / 200 mm/s
Tensile load, cable (max.)	600 N
IEC 60529: Degree of protection	IP67
Operating temperature	-25 to +55 °C
short-term (15 min)	-40 to +80 °C
Storage temperature	-40 to +80 °C
Weight (without/with aluminium profile)	0.46 / 0.76 kg/m
<b>Electrical operating conditions</b>	
Terminal resistance	$8k2 \pm 1 \%$
Rated capacity (max.)	250 mW
Contact transition resistance	< 400 Ohm (per sensor)
Number of sensors type BK	max. 3 in series (for more information refer to the chapter <i>Limits</i> )
Switching voltage (max.)	DC 24 V
Switching current (min. / max.)	1 mA / 10 mA
Connection cable	$\varnothing 2.9 \text{ mm PUR } 2 \times 0.25 \text{ mm}^2$
<b>Dimensional tolerances</b>	
Length according to	ISO 3302 L2
Profile section according to	ISO 3302 E2

Bend radii:

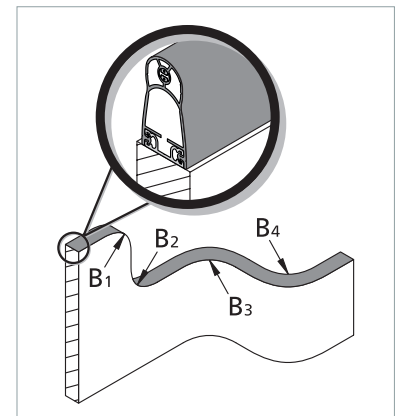

## Dimensions and distances

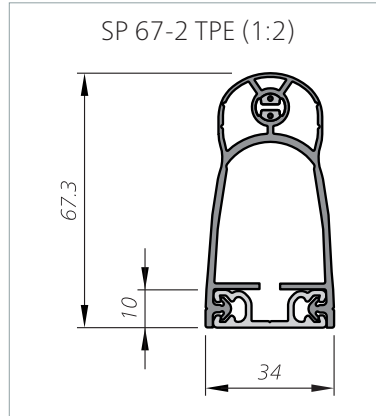

Dimensional tolerances according to ISO 3302 E2/L2.

### Test conditions

according to ISO 13856-2

- Installation position B
- Temperature +20 °C
- Measurement point c3
- Test sample 1 with Ø 80 mm
- without control unit

All data stated here is documented in EC design type test certificates.

### Force-distance ratios

Actuation force	41 N
Response time	880 ms
Actuation distance (A)	8.8 mm
Overtravel distance	
up to 250 N (B1)	35.7 mm
up to 400 N (B2)	37.9 mm
up to 600 N (C)	41 mm
Total deformation	49.8 mm

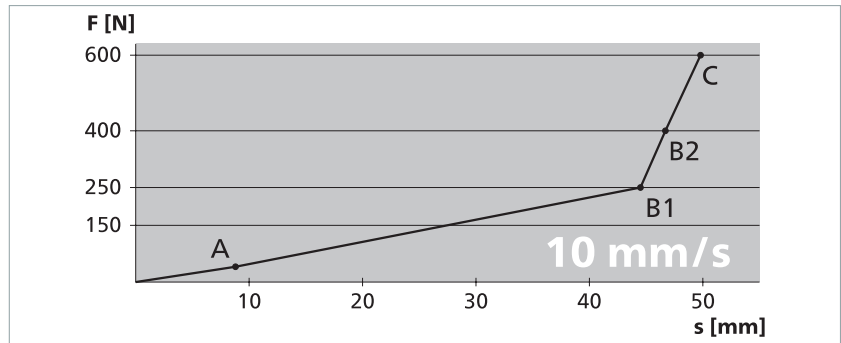

Actuation force	42 N
Response time	101 ms
Actuation distance (A)	10.1 mm
Overtravel distance	
up to 250 N (B1)	35.4 mm
up to 400 N (B2)	37.8 mm
up to 600 N (C)	39.8 mm
Total deformation	49.9 mm

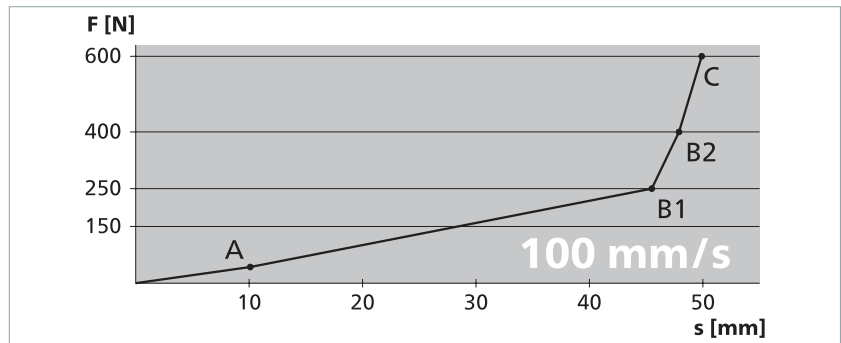

Actuation force	45 N
Response time	51.5 ms
Actuation distance (A)	10.3 mm
Overtravel distance	
up to 250 N (B1)	36.5 mm
up to 400 N (B2)	39.4 mm
up to 600 N (C)	41.3 mm
Total deformation	51.6 mm

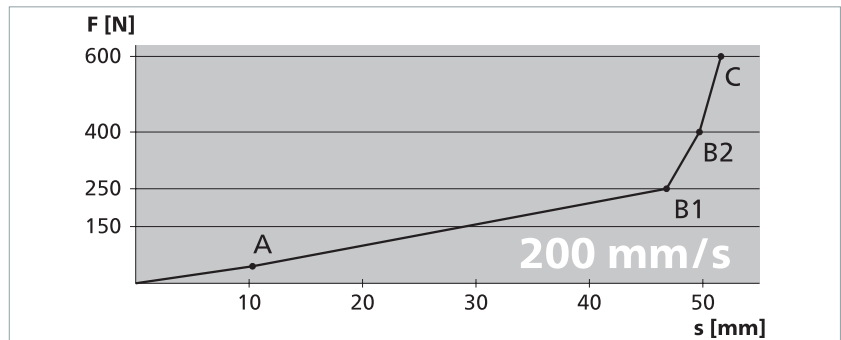

## Marking

If you combine sensors with control units and thereby release pressure-sensitive safeguards onto the market, observe the basic regulations in ISO 13856.

Apart from technical requirements, this applies in particular also to marking and information for use.

## Conformity

### EC design test

The product was tested by an independent institute.

An EC design type test certificate confirms conformity.

The EC design type test certificate is available in the download section of the website: [www.mayser.com/en/downloads](http://www.mayser.com/en/downloads)

## UL certification

The design type of the product complies with the basic requirements of: UL certification

- UL 325

