

# Thin Gripper **RCP6-GRT7**

*Equipped with a Battery-less Absolute Encoder*



# Gripper First!

## New Type Equipped with Battery-less Absolute Encoder!!

### Flat shape, thin size with height of 39 mm achieved.

Advantage

1

## Equipped with a Battery-less Absolute Encoder as Standard

With orthogonal axis + gripper pick and place, all axes can be configured with battery-less absolute encoder equipped products. **Home return is no longer required when restarting the equipment; you can move to the next operation while gripping the workpiece.**

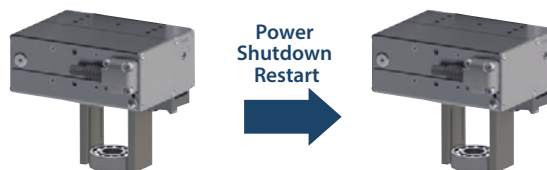
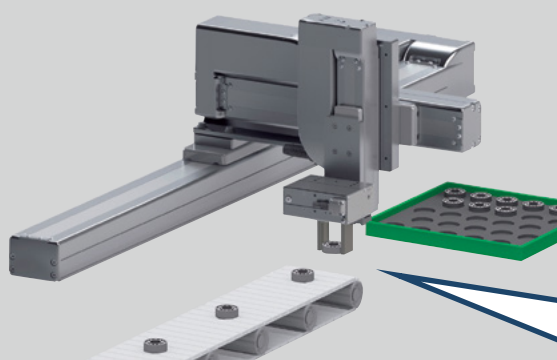

It remembers the position even after Shutdown --> Restart. It retains the grip.

\* For push holding, the push status is not retained.

Advantage

2

## Flat Shape with Height of 39 mm

The height has been reduced.

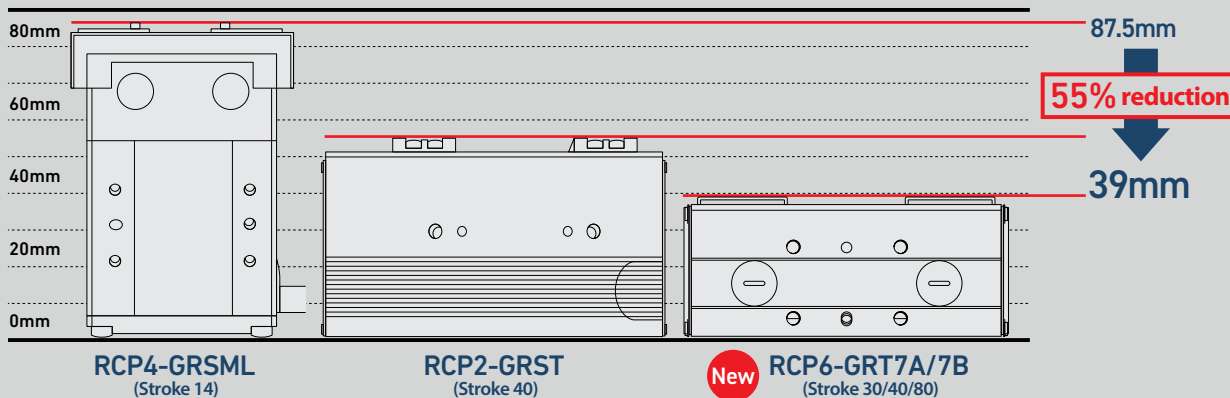

Advantage

3

## High Rigidity

By adopting an integrated body frame guide with proven performance for linear axes, the gripping point distance and overhang amount have been improved greatly.

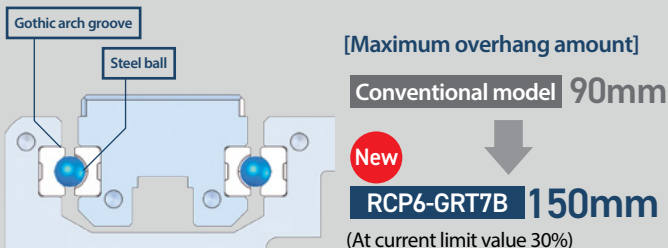

Advantage

4

## High Grip Force

IAI presents our highest-class grip force. (Current limit value 70%)

Model	GRT7A	GRT7B	
Type	High speed type	High speed type	High grip force type
Maximum grip force (Fingers on both sides)	120N	150N	300N

1



Advantage  
**5**

## Improved Mounting Freedom

4-side mounting (including mounting on the finger operation surface), wiring exit direction and surface can be changed. Select the mounting/wiring position according to the equipment.

### Mounting surface

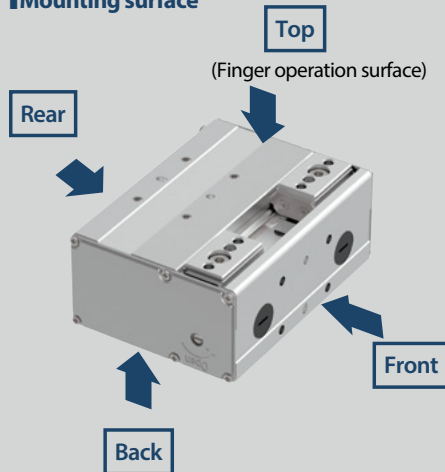

### Wiring exit direction

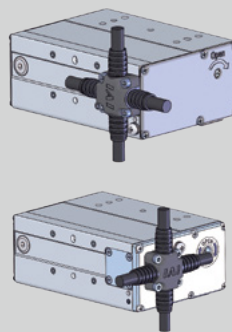

Advantage  
**6**

## Inexpensive

Compared with our products with equivalent stroke, it is 39% cheaper.

Conventional model  
RCP2-GRST(40ST)



About 39% reduction

New  
RCP6-GRT7B(40ST)

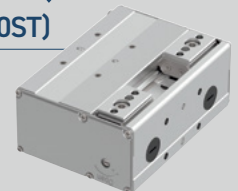

## Model Specification Items

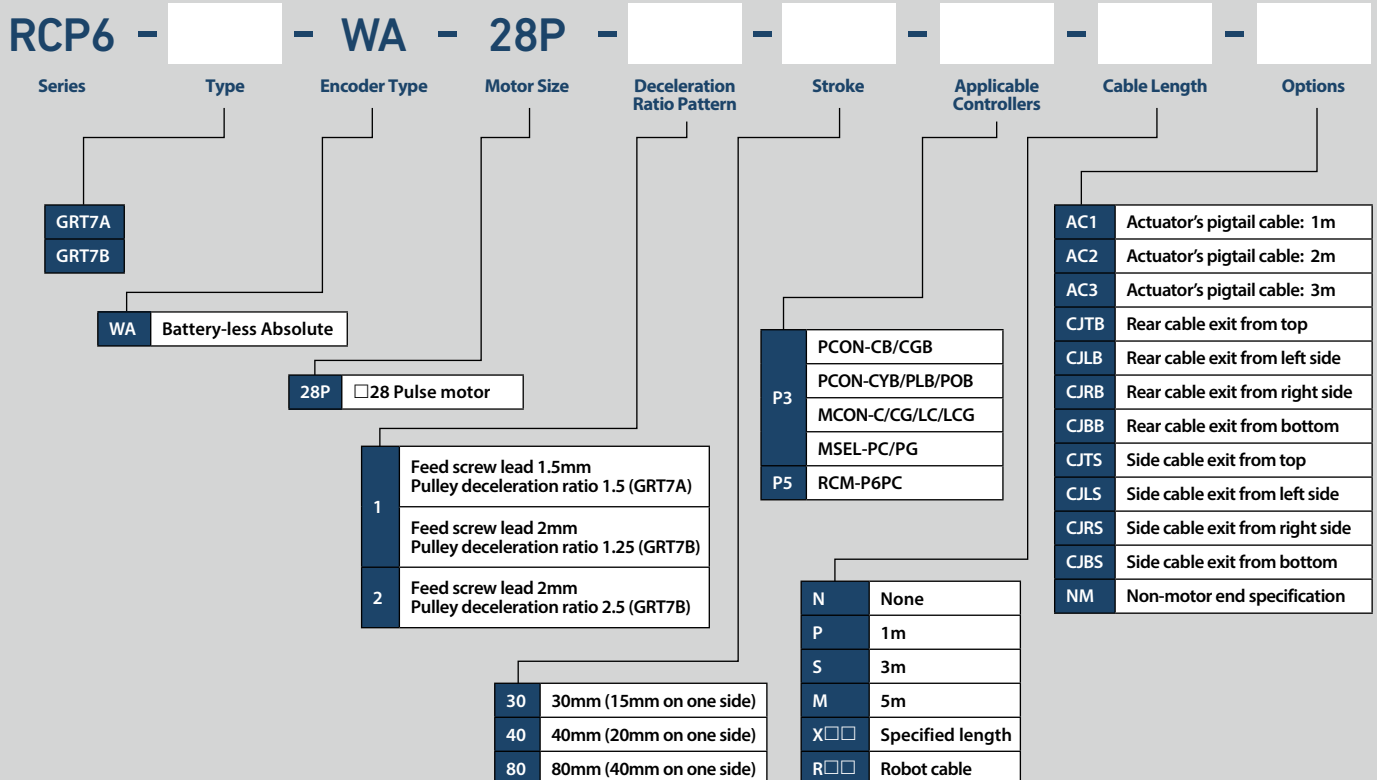

# RCP6-GRT7A

2-Finger Gripper Thin Slide Type Body Width 66 mm 24v Stepper Motor

Model Specification Items	<b>RCP6-GRT7A-WA-28P-1-30</b>	Applicable Controllers	Cable Length	Options
Series	Type	Encoder Type	Motor Type	Deceleration Ratio Pattern
WA: Battery-less Absolute	28P: Stepper Motor 28□ Size	1: Feed Screw Lead 1.5mm Pulley Deceleration Ratio 1.5	30: 30mm	P3: PCON MCON MSEL P5: RCM-P6PC
		N: None P: 1m S: 3m M: 5m X□□: Specified Length	Please refer to the option price list below. * Be sure to fill in one of the following options for the cable exit direction.	

\* Does not include a controller.  
\* Please refer to P.2 for more information about the model specification items.

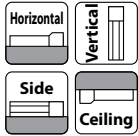

### Gripping Force vs. Electric Current Limit

The gripping (pushing) force can be adjusted freely within the range of electric current limits of 20% to 70%.

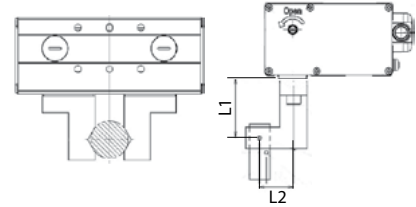

\* For L1 and L2, please refer to the gripper selection method on P.9.  
\* The gripping force in the graph below assumes that L1 and L2 the figure above are zero. (Refer to p.10 for the rough guide gripping force at each distance of L1.) Also note that the gripping force is the sum of the gripping forces of both fingers.

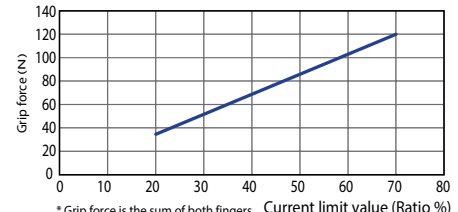

\* Grip force is the sum of both fingers

\* The gripping force graph above shows numbers for reference. Please allow margins up to ±15%.

\* Please note that, when gripping (pushing), the speed is fixed at 5 mm/s.



- The maximum opening/closing speed indicates the operating speed on one side. The relative operating speed is twice this value.
- The maximum gripping force is the sum of the gripping forces of both fingers, at a gripping point where there is no offset or overhang distance. The workpiece weight that can be actually moved depends on the friction coefficient between the gripper fingers and the workpiece, as well as on the shape of the workpiece. As a rough guide, a workpiece's weight should not exceed 1/10 to 1/20 of the gripping force. (See page 9 for details.)
- The rated acceleration while moving is 0.3 G.

### Actuator Specifications

Model specification items	Deceleration ratio pattern	Max grip force (N)	Stroke (mm)
RCP6-GRT7A-WA-28P-1-30-①-②-③	1	120 (one side 60)	30 (one side 15)

Legend: ① Applicable Controllers ② Cable Length ③ Options

### Stroke and Max Opening/Closing Speed

Stroke	30 (mm)
Deceleration ratio	75
1	

(Unit: mm/s)

### Stroke

Stroke (mm)	RCP6-GRT7A
30	○

### ② Cable Length

Type	Cable code
Standard type	P(1m)
	S(3m)
	M(5m)
Specified length	X06 (6m) ~ X10 (10m)
	X11 (11m) ~ X15 (15m)
	X16 (16m) ~ X20 (20m)*
Robot cable	R01 (1m) ~ R03 (3m)
	R04 (4m) ~ R05 (5m)
	R06 (6m) ~ R10 (10m)
	R11 (11m) ~ R15 (15m)
	R16 (16m) ~ R20 (20m)*

Cable between actuator and controller.

\* When changing the Actuator's pigtail cable length as an option, make sure the total cable length between the actuator and the controller is within 20m.

### ③ Options

Name	Option code	Reference page
Actuator's pigtail cable 1m specification	AC1	P. 8
Actuator's pigtail cable 2m specification	AC2	P. 8
Actuator's pigtail cable 3m specification	AC3	P. 8
Rear cable exit from top	CJTB	P. 8
Rear cable exit from left side	CJLB	P. 8
Rear cable exit from right side	CJRB	P. 8
Rear cable exit from bottom	CJBB	P. 8
Side cable exit from top	CJTS	P. 8
Side cable exit from left side	CJLS	P. 8
Side cable exit from right side	CJRS	P. 8
Side cable exit from bottom	CJBS	P. 8
Non-motor end specification	NM	P. 8

\* Be sure to select a symbol for the cable exit direction.

### Actuator Specifications

Item	Description
Drive system	Timing belt + left/right trapezoidal screw φ8
Positioning repeatability	±0.01mm
Backlash	One side 0.2mm or less
Lost motion	One side 0.2mm or less
Allowable static moment	Ma: 3.6N·m Mb: 3.6N·m Mc: 10.2N·m
Mass	0.46kg
Ambient operating temperature/humidity	0~40°C, 85% RH or less (non-condensing)



# RCP6-GRT7B

2-Finger Gripper    Thin Slide Type    Body Width 66 mm    24v Stepper Motor

Model Specification Items	<b>RCP6-GRT7B-WA-28P</b>	Series	Type	Encoder Type	Motor Type	Deceleration Ratio Pattern	Stroke	Applicable Controllers	Cable Length	Options
		WA: Battery-less Absolute	28P: Stepper Motor 28□ Size		1: Feed Screw Lead 2mm Pulley Deceleration Ratio 1.25 2: Feed Screw Lead 2mm Pulley Deceleration Ratio 2.5	40:40mm 80:80mm	P3: PCON MCON MSEL P5: RCM-P6PC	N: None P: 1m S: 3m M: 5m X□□: Specified Length	Please refer to the option price list below. * Be sure to fill in one of the following options for the cable exit direction.	

\* Does not include a controller.  
\* Please refer to P.2 for more information about the model specification items.

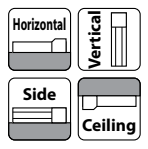

### Gripping Force vs. Electric Current Limit

The gripping (pushing) force can be adjusted freely within the range of electric current limits of 20% to 70%.

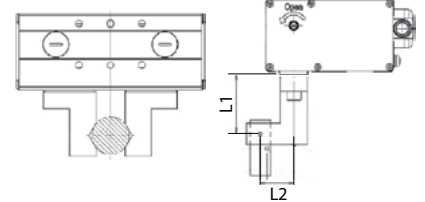

\* For L1 and L2, please refer to the gripper selection method on P.9.  
\* The gripping force in the graph below assumes that L1 and L2 the figure above are zero. (Refer to p.10 for the rough guide gripping force at each distance of L1.) Also note that the gripping force is the sum of the gripping forces of both fingers.

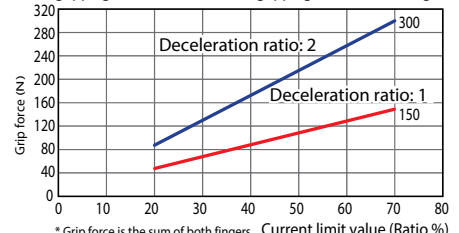

\* Grip force is the sum of both fingers

\* The gripping force graph above shows numbers for reference. Please allow margins up to ±15%.

\* Please note that, when gripping (pushing), the speed is fixed at 5 mm/s.

- POINT Selection Notes**
- (1) The maximum opening/closing speed indicates the operating speed on one side. The relative operating speed is twice this value.
  - (2) The maximum gripping force is the sum of the gripping forces of both fingers, at a gripping point where there is no offset or overhang distance. The workpiece weight that can be actually moved depends on the friction coefficient between the gripper fingers and the workpiece, as well as on the shape of the workpiece. As a rough guide, a workpiece's weight should not exceed 1/10 to 1/20 of the gripping force. (See page 9 for details.)
  - (3) The rated acceleration while moving is 0.3 G.

### Actuator Specifications

Model specification items	Deceleration ratio pattern	Max grip force (N)	Stroke (mm)
RCP6-GRT7B-WA-28P-1-①-②-③-④	1	150 (one side 75)	40 80 (One side 20), (One side 40)
RCP6-GRT7B-WA-28P-2-①-②-③-④	2	300 (one side 150)	40 80 (One side 20), (One side 40)

Legend: ① Stroke ② Applicable Controllers ③ Cable Length ④ Options

### Stroke and Max Opening/Closing Speed

Deceleration ratio	Stroke	40~80 (mm)
1		120
2		60

(Unit: mm/s)

#### ① Stroke

Stroke (mm)	RCP6-GRT7B
40	<input type="radio"/>
80	<input type="radio"/>

#### ③ Cable Length

Type	Cable code
Standard type	P(1m)
	S(3m)
	M(5m)
Specified length	X06 (6m) ~ X10 (10m)
	X11 (11m) ~ X15 (15m)
	X16 (16m) ~ X20 (20m)*
Robot cable	R01 (1m) ~ R03 (3m)
	R04 (4m) ~ R05 (5m)
	R06 (6m) ~ R10 (10m)
	R11 (11m) ~ R15 (15m)
	R16 (16m) ~ R20 (20m)*

Cable between actuator and controller.  
\* When changing the Actuator's pigtail cable length as an option, make sure the total cable length between the actuator and the controller is within 20m.

#### ④ Options

Name	Option code	Reference page
Actuator's pigtail cable 1m specification	AC1	P. 8
Actuator's pigtail cable 2m specification	AC2	P. 8
Actuator's pigtail cable 3m specification	AC3	P. 8
Rear cable exit from top	CJTB	P. 8
Rear cable exit from left side	CJLB	P. 8
Rear cable exit from right side	CJRB	P. 8
Rear cable exit from bottom	CJBB	P. 8
Side cable exit from top	CJTS	P. 8
Side cable exit from left side	CJLS	P. 8
Side cable exit from right side	CJRS	P. 8
Side cable exit from bottom	CJBS	P. 8
Non-motor end specification	NM	P. 8

\* Be sure to select a symbol for the cable exit direction.

### Actuator Specifications

Item	Description
Drive system	Timing belt + left/right trapezoidal screw φ10
Positioning repeatability	±0.01mm
Backlash	One side 0.2mm or less
Lost motion	One side 0.2mm or less
Allowable static moment	Ma: 7.5N·m Mb: 7.5N·m Mc: 15.3N·m
Mass	0.68kg (40 stroke), 0.84kg (80 stroke)
Ambient operating temperature/humidity	0~40°C, 85% RH or less (non-condensing)







# Options

## Actuator's pigtail cable □ Specification

Model **AC1/AC2/AC3**

Description Although the standard length of the Actuator's pigtail cable is 200mm, it can be changed to 1000/2000/3000mm as an option.

## Cable exit direction

Model **CJTB/CJLB/CJRB/CJBB/CJTS/CJLS/CJRS/CJBS**

Description The mounting direction of the Actuator's pigtail cable can be changed to top, bottom, left, or right.

### CJ□B (Back)

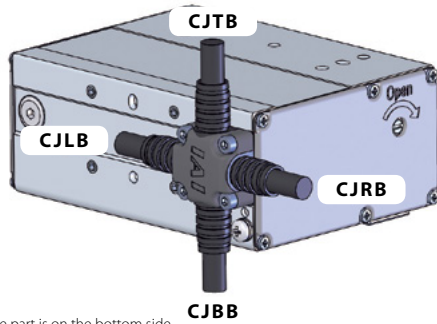

\* The movable part is on the bottom side

### CJ□S (Side)

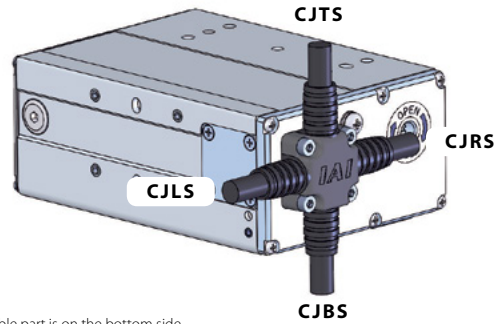

\* The movable part is on the bottom side

## Non-motor end specification

Model **NM**

Description The home position is set to the finger open side. If you want to set the home position on the opposite end due to the layout of your system, etc., you can do so by selecting this option. (Since your actuator has been shipped with its home position pre-adjusted at the factory, you must send the actuator back to us for adjustment to change the home direction after delivery.)

# Gripper Selection Method

## Slide type

**Step 1**  
Check the required grip force and allowable workpiece mass



**Step 2**  
Check the gripping point distance



**Step 3**  
Check external force applied to fingers

### Step 1 Check the required grip force and allowable workpiece mass

When gripping the workpiece with frictional grip force, calculate the required grip force as follows.

#### (1) For normal transfer

**F:** Grip force (N) ... Total value of push force of each claw  
**μ:** Static friction coefficient between the finger attachment and the workpiece  
**m:** Workpiece mass (kg)  
**g:** Gravitational acceleration (=9.8m/s<sup>2</sup>)

- The conditions under which the work part remains statically gripped without dropping are as follows:

$$F\mu > W \quad F > \frac{mg}{\mu}$$

- Assuming a recommended safety factor of 2 for normal transfer, the required gripping force is calculated as follows:

$$F > \frac{mg}{\mu} \times 2 \text{ (safety factor)}$$

- When the friction coefficient is μ0.1 ~ 0.2

$$F > \frac{mg}{0.1\sim 0.2} \times 2 = (10\sim 20) \times mg$$

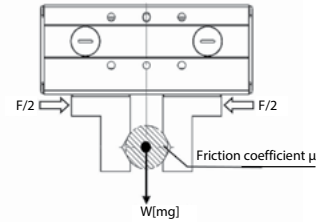

#### For ordinary workpiece transferring

Required grip force: ▶ **10~20 times or more the workpiece mass**

Max. allowable mass: ▶ **Not more than 1/10th to 1/20th the gripping force**

\* The greater the coefficient of static friction, the greater than maximum allowable work part mass becomes. To ensure safety, however, select a model that can generate a gripping force of at least 10 to 20 times this work part mass.

#### (2) When considerable acceleration, deceleration, or impact force is applied when transferring the workpiece

In addition to gravity, if a stronger inertial force operates on the workpiece then select a model with an even higher safety factor.

#### When large acceleration, deceleration, or shock is applied

Required grip force: ▶ **30~50 times or more the workpiece mass**

Max. allowable mass: ▶ **1/30~1/50 or less of the grip force**

### Step 2 Check the gripping point distance

Use the actuator so that the distances (L1, L2) from the finger mounting surface to the gripping point fall in the ranges specified below. If the limits are exceeded, excessive moments may act upon the sliding part of the finger and internal mechanism, negatively affecting the service life of the actuator.

RCP6-GRT7A

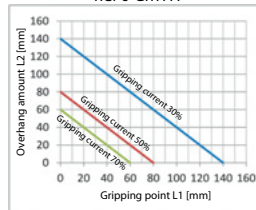

RCP6-GRT7B (Deceleration ratio: 1)

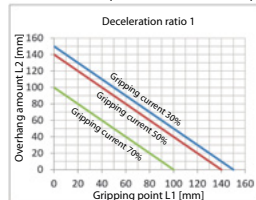

RCP6-GRT7B (Deceleration ratio: 2)

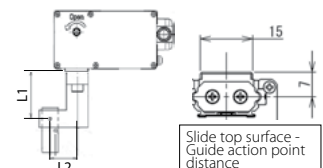
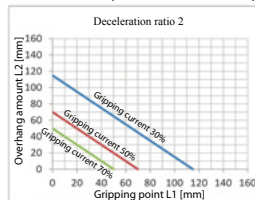

Even if the gripping point distance is within the limit range, keep it as small and lightweight as possible.

If the fingers are long and large, or if the mass is large, inertial force and bending moment during opening and closing may worsen the performance and adversely affect the guide section.

# Gripper Selection Method

## Step 3 Check external force applied to fingers

### (1) Allowable vertical load

Make sure that the vertical load applied to each finger is less than the allowable load.

### (2) Allowable load moment

Calculate  $M_a$  and  $M_c$  with  $L_1$ , and  $M_b$  with  $L_2$ . Make sure the moment applied to each finger is less than the maximum allowable load moment.

- The allowable external force when applying moment load to each claw is

$$\text{Allowable load } F(N) > \frac{M \text{ (Maximum allowable moment (N}\cdot\text{m))}}{L(\text{mm}) \times 10^{-3}}$$

Calculate both  $L_1$  and  $L_2$  for the allowable load  $F$  (N).

Check that the external force applied to the finger is less than the calculated allowable load  $F$  (N) (the smaller value of  $L_1$  and  $L_2$ ).

Model	Allowable vertical load $F$ (N)(Note 1)	Maximum allowable load moment (N·m) (Note 2)		
		$M_a$	$M_b$	$M_c$
RCP6-GRT7A	598	3.6	3.6	10.2
RCP6-GRT7B	898	7.5	7.5	15.3

(Note 1) The allowable value above indicates a static value. (Note 2) Indicates the allowable value per finger.

\* The weight of the finger and the workpiece weight are also part of the external force. Other external forces applied to the fingers are the centrifugal force when swiveling the gripper with the workpiece gripped and the inertia force due to acceleration/deceleration during travel.

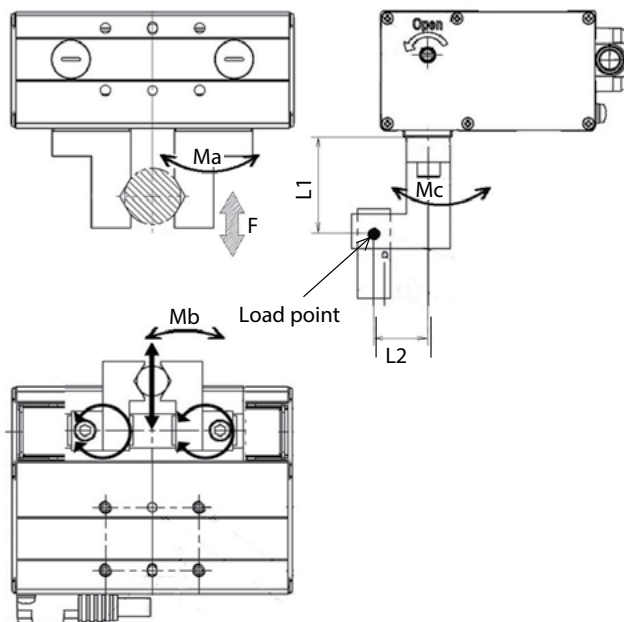

\* The load point above indicates the load position on the fingers. The position varies depending on the type of load.

- Load due to grip force: Gripping point
- Load due to gravity: Center mass location
- Inertial force during travel, centrifugal force during swivel: Center mass location

The load moment is the total value calculated for each type of load.

## Guideline for load shape and mass

- These graphs show the grip force based on the gripping point distance when the maximum grip force is taken as 100%.
- The gripping point distance indicates the vertical distance from the finger attachment mounting surface to the gripping point.
- Grip force may vary due to individual differences. Consider this as a guideline only.

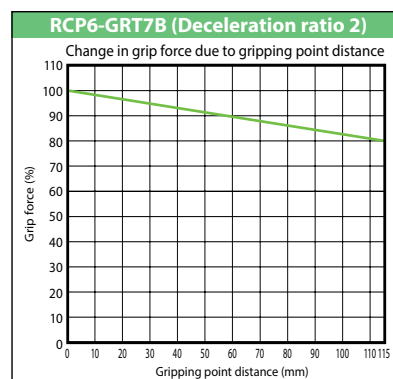
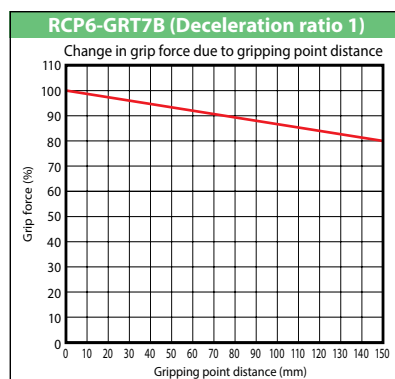
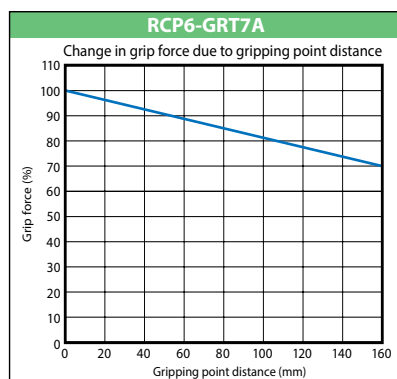

---

## **IAI America, Inc.**

**Headquarters:** 2690 W. 237th Street, Torrance, CA 90505 (800) 736-1712

**Chicago Office:** 110 E. State Pkwy, Schaumburg, IL 60173 (800) 944-0333

**Atlanta Office:** 1220 Kennestone Circle, Suite 108, Marietta, GA 30066 (888) 354-9470

**[www.intelligentactuator.com](http://www.intelligentactuator.com)**

The information contained in this product brochure  
may change without prior notice due to product improvements.

## **IAI Industrieroboter GmbH**

Ober der Röth 4, D-65824 Schwalbach am Taunus, Germany

## **IAI (Shanghai) Co., Ltd.**

Shanghai Jiahua Business Center A8-303, 808,  
Hongqiao Rd., Shanghai 200030, China

## **IAI Robot (Thailand) Co., Ltd.**

825 Phairokijja Tower 12th Floor, Bangna-Trad RD.,  
Bangna, Bangna, Bangkok 10260, Thailand