

ROBO Cylinder IK Series Catalog

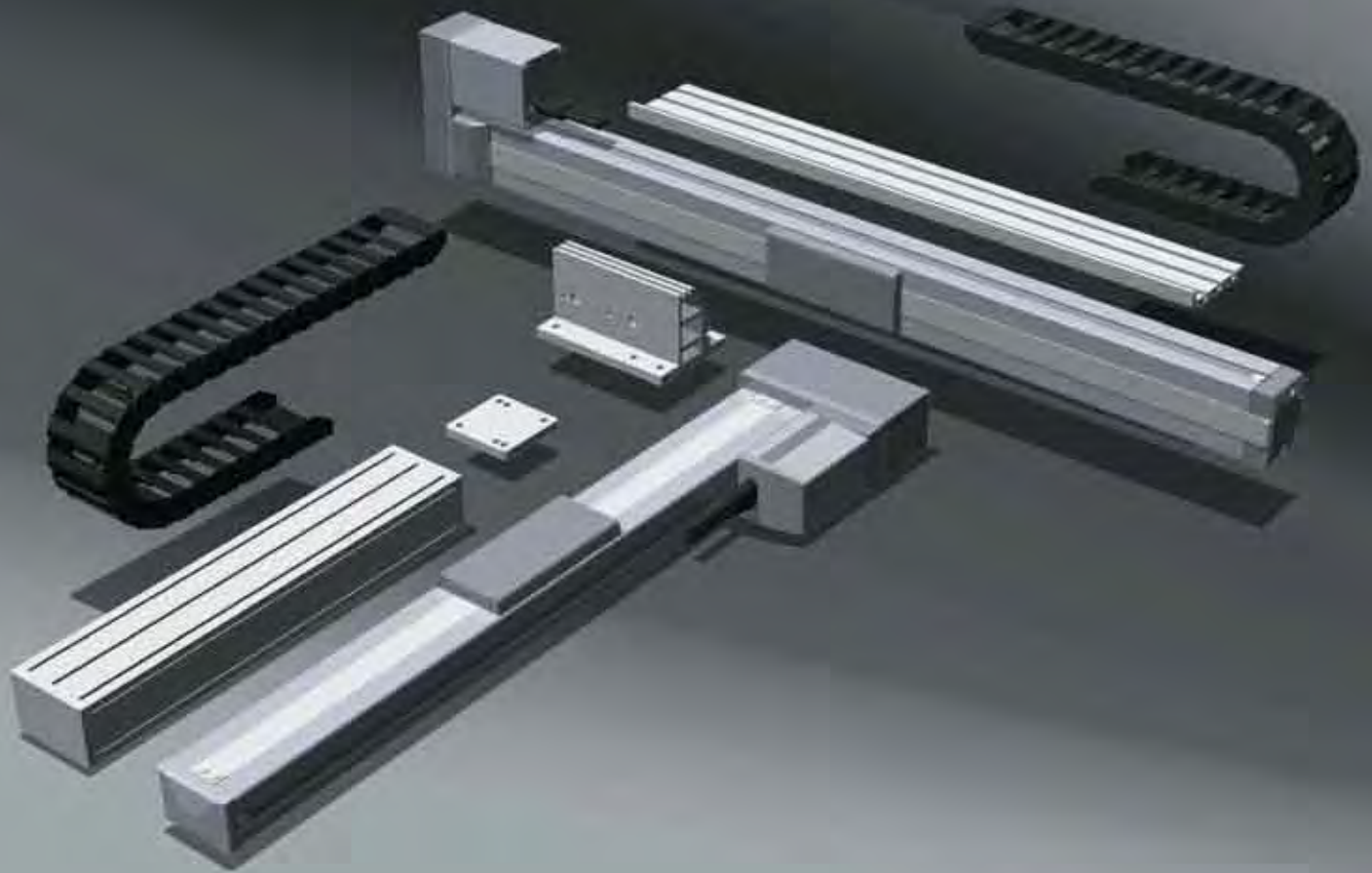

ROBO Cylinder IK Series

IK Series: Components



1. Wide Variation

The engineers at IAI have worked extensively to produce the highest quality products at affordable prices. The new IK Series lineup offers many variations and can be easily integrated and prepared to your specific needs.

2. Motor Options

The IK Series is offered in both pulse and servo motors. Choose the pulse motor for applications requiring high thrust at low speeds. Choose the servo motor for applications requiring constant thrust regardless of the operating speed.

3. Easy Assembly

The ROBO Cylinder IK Series multi-axes kit includes everything needed for fast and easy assembly.

Components



Assembled



Multi-Axes Systems

IK Series: Assembled



4. High Functionality

Combined with the PCON/PSEL/SCON/SSEL/XSEL controllers, complex programming is made easy.



5. Quality and Innovation

We at IAI are always working to offer high quality and innovative solutions tailored for your specific application. Whenever you need support, IAI's experienced teams of technical support engineers are available to help you diagnose and troubleshoot IAI products. When you require innovative and high quality robots, excellent service and support for your unique needs, demand IAI!

IAI
Quality and Innovation

Wide-ranging Lineup Lineup of IK Series

Combinations

XYB (XY, base mount)

Page

IK2-PXBD Series ...13~
IK2-SXBD Series ...43~

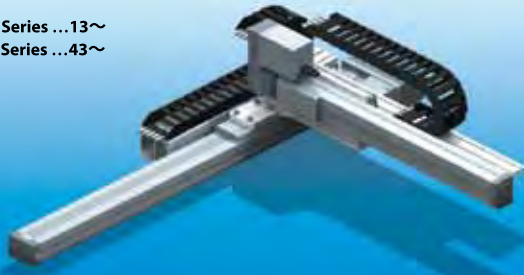

Page

IK2-PXBC Series ...21~
IK2-SXBC Series ...51~



•IK2-PXBD Series •IK2-SXBD Series

		Maximum X-axis stroke	Maximum Y-axis stroke	Load capacity at maximum Y-axis stroke
Single-slider	Y high-speed type	600mm	200mm	2.5kg
	Y medium-speed type	600mm	200mm	5.0kg
Double-slider	Y high-speed type	450mm	400mm	2.0kg
	Y medium-speed type	450mm	400mm	4.0kg

•IK2-PXBC Series •IK2-SXBC Series

		Maximum X-axis stroke	Maximum Y-axis stroke	Load capacity at maximum Y-axis stroke
Single-slider	Y high-speed type	600mm	200mm	3.0kg
	Y medium-speed type	600mm	200mm	6.0kg
Double-slider	Y high-speed type	450mm	400mm	3.0kg
	Y medium-speed type	450mm	400mm	6.0kg

XZ (Upright type)

Page

IK2-PXZB Series ...37~
IK2-SXZB Series ...75~



•IK2-PXZB Series •IK2-SXZB Series

		Maximum X-axis stroke	Maximum Z-axis stroke	Load capacity at maximum Y-axis stroke
Single-slider	X high-speed/Z high-speed type	1,000mm	250mm	1.5kg
	X high-speed/Z medium-speed type	1,000mm	250mm	2.5kg
	X high-speed/Z low-speed type	1,000mm	250mm	3.0kg
Double-slider	X high-speed/Z high-speed type	800mm	300mm	1.5kg
	X high-speed/Z medium-speed type	800mm	300mm	3.0kg
	X high-speed/Z low-speed type	800mm	300mm	5.5kg

YZB (Cross type, base mount)

Page

IK2-PYBB Series ...41~
IK2-SYBB Series ...79~



•IK2-PYBB Series •IK2-SYBB Series

		Maximum X-axis stroke	Maximum Z-axis stroke	Load capacity at maximum Y-axis stroke
Single-slider	X high-speed/Z high-speed type	1,000mm	300mm	1.5kg
	X high-speed/Z medium-speed type	1,000mm	300mm	3.0kg
	X high-speed/Z low-speed type	1,000mm	300mm	5.5kg

IK2-P Series / IK3-P Series ROBO Cylinder RCP2 combinations based on pulse motor

IK2-S Series / IK3-S Series ROBO Cylinder RCS2 combinations based on servo motor

Page

IK2-PXBB Series ...29~
IK2-SXBB Series ...59~

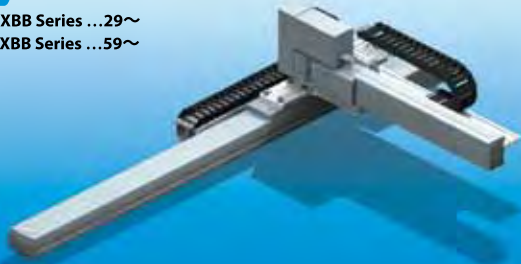

Page

IK2-SXBA Series ...67~

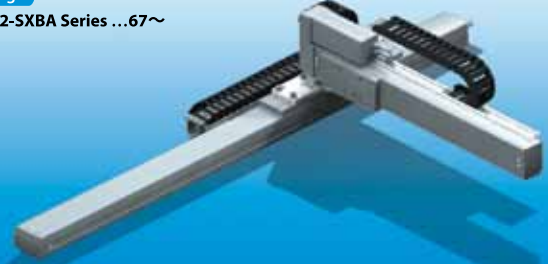

•IK2-PXBB Series •IK2-SXBB Series

		Maximum X-axis stroke	Maximum Y-axis stroke	Load capacity at maximum Y-axis stroke
Single-slider	High-speed type	1,000mm	300mm	6.0kg
	Medium-speed type	1,000mm	300mm	8.0kg
Double-slider	High-speed type	800mm	400mm	5.5kg
	Medium-speed type	800mm	400mm	10.5kg

•IK2-SXBA Series

		Maximum X-axis stroke	Maximum Y-axis stroke	Load capacity at maximum Y-axis stroke
Single-slider	High-speed type	1,000mm	350mm	7.0kg
	Medium-speed type	1,000mm	200mm	12.5kg
Double-slider	High-speed type	800mm	400mm	10.0kg
	Medium-speed type	800mm	400mm	11.5kg

3-axis type (XYB+Z, base mount)

Page

IK3-Series ...81~



•IK3 Series

		Maximum X-axis stroke	Maximum Y-axis stroke	Maximum Z-axis stroke	Load capacity at maximum Y-axis stroke
Single-slider	X high-speed/Y high-speed/Z high-speed type	1,000mm	300mm	200mm	1.0kg
	X high-speed/Y high-speed/Z medium-speed type	1,000mm	300mm	200mm	2.0kg
	X high-speed/Y high-speed/Z low-speed type	1,000mm	300mm	200mm	4.0kg
Double-slider	X high-speed/Y high-speed/Z high-speed type	800mm	400mm	200mm	1.0kg
	X high-speed/Y high-speed/Z medium-speed type	800mm	400mm	200mm	2.0kg
	X high-speed/Y high-speed/Z low-speed type	800mm	400mm	200mm	4.0kg

2-axis combination – Axis configurations

	Axis 1	Axis 2
IK2-PXBD	RCP2-SS7□	RCP2-SA5R
IK2-SXBD	RCS2-SS7□	RCS2-SA5R
IK2-PXBC	RCP2-SS7□	RCP2-SA6R
IK2-SXBC	RCS2-SS7□	RCS2-SA6R
IK2-PXBB	RCP2-SS8□	RCP2-SA7R
IK2-SXBB	RCS2-SS8□ (100W)	RCS2-SA7R
IK2-SXBA	RCS2-SS8□ (150W)	RCS2-SS8R (100W)
IK2-PXZB	RCP2-SS8□	RCP2-SA7R
IK2-SXZB	RCS2-SS8□ (100W)	RCS2-SA7R
IK2-PYBB	RCP2-SS8□	RCP2-SA7R
IK2-SYBB	RCS2-SS8□ (100W)	RCS2-SA7R

3-axis combination – Axis configurations

	X axis	Y axis	Z axis
IK3	RCP2-SS8□	RCP2-SA7R	RCP2-SA6R
	RCS2-SS8□ (100W)	RCS2-SA7R	RCS2-SA6R

IK Series

The IK Series is a set that includes the following components needed to assemble the cartesian robot.

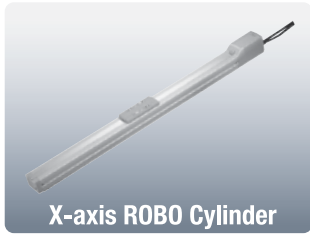

X-axis ROBO Cylinder

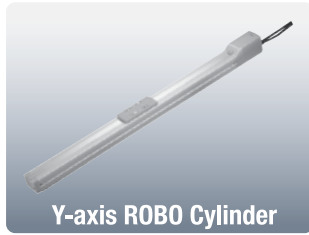

Y-axis ROBO Cylinder

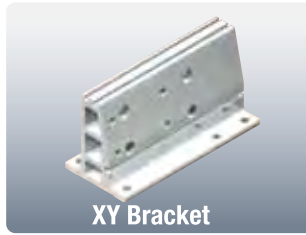

XY Bracket



X Guide Rail

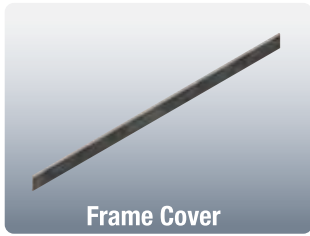

Frame Cover



Y Guide Rail

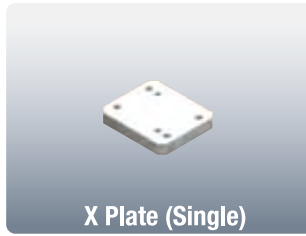

X Plate (Single)

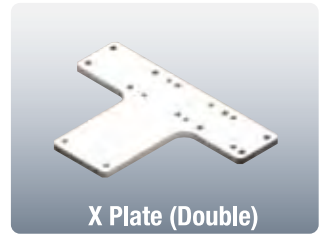

X Plate (Double)



Cable Track

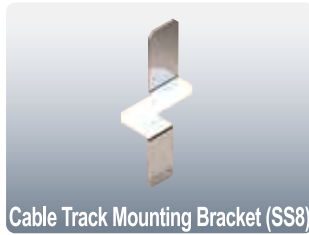

Cable Track Mounting Bracket (SS8)

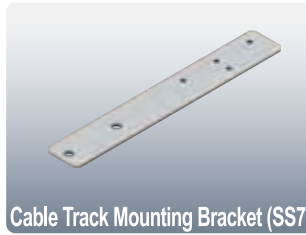

Cable Track Mounting Bracket (SS7)

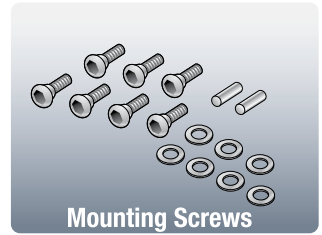

Mounting Screws

Note: The above images are provided for reference purposes only. The actual components may vary depending on the combination type, direction, etc.

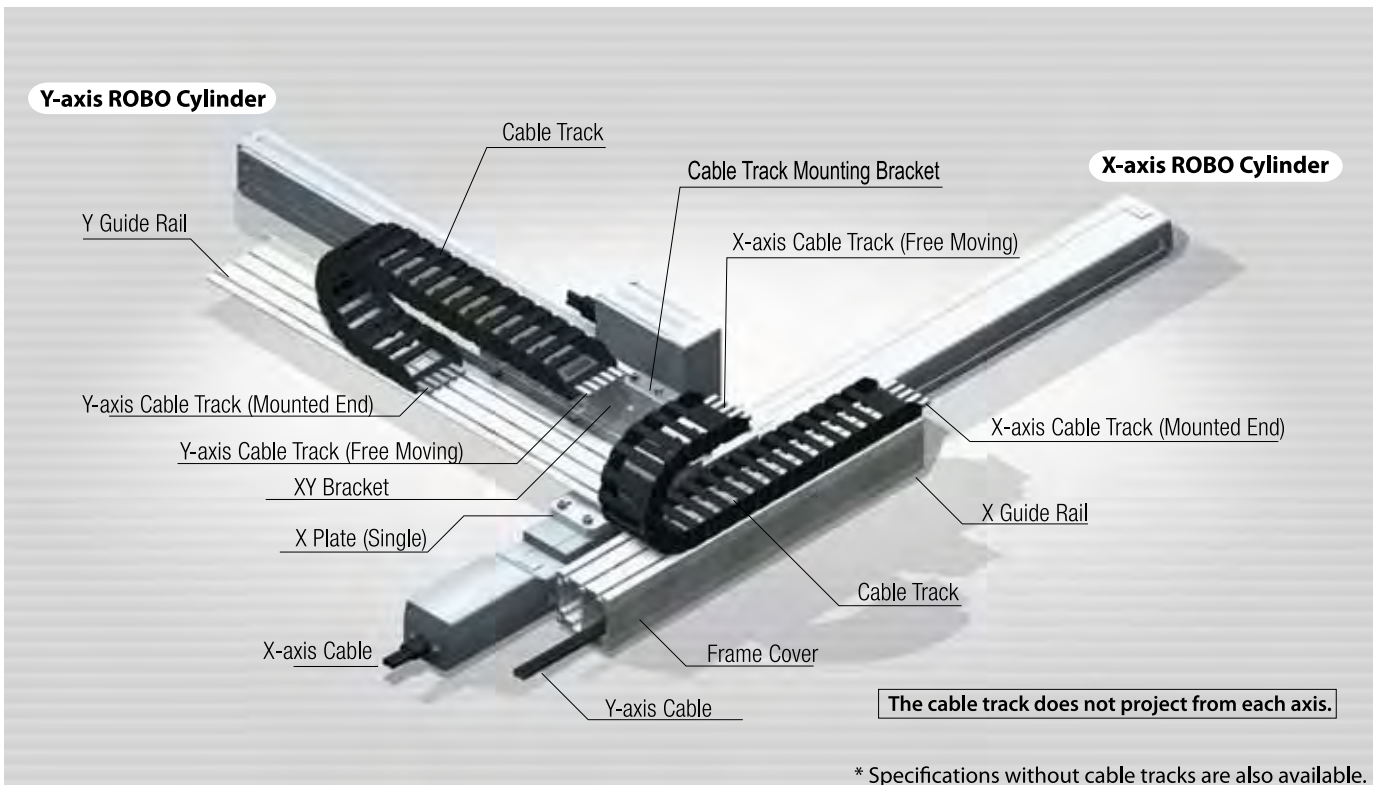

* Specifications without cable tracks are also available.

Load Capacity Graphs for XYB Combinations

[IK2-PXBD/IK2-SXBD]

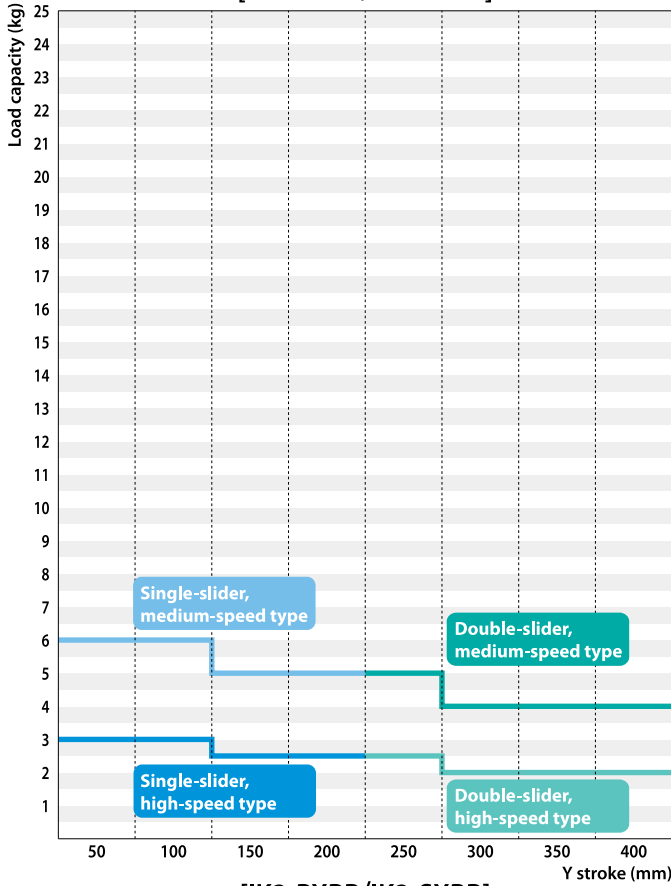

[IK2-PXBC/IK2-SXBC]

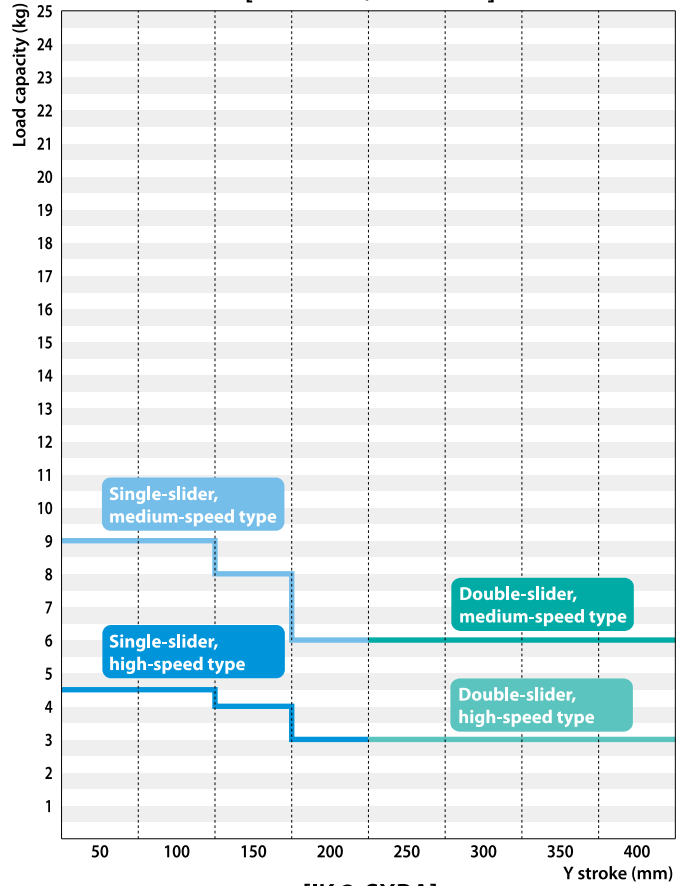

[IK2-PXBB/IK2-SXBB]

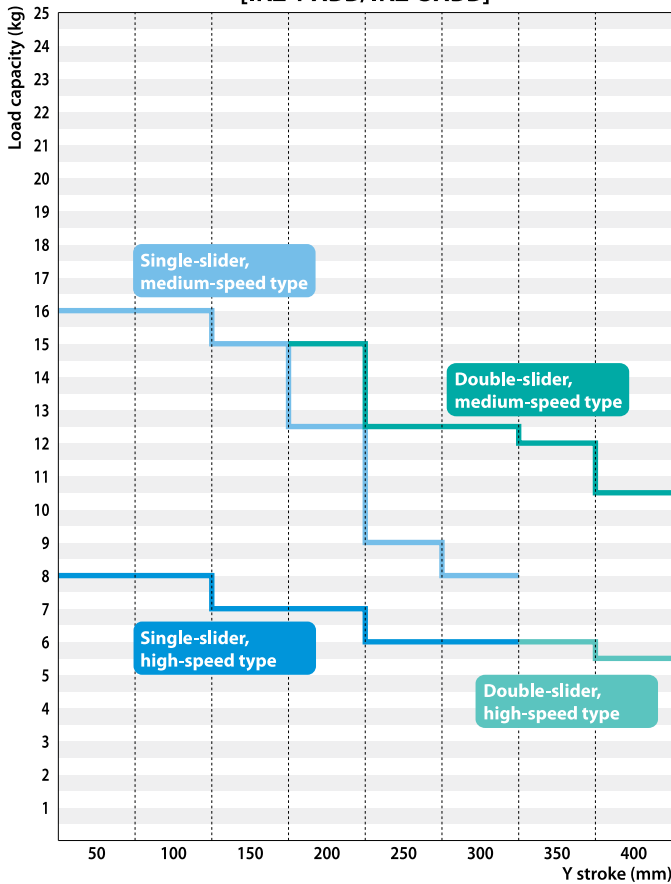

[IK 2-SXBA]

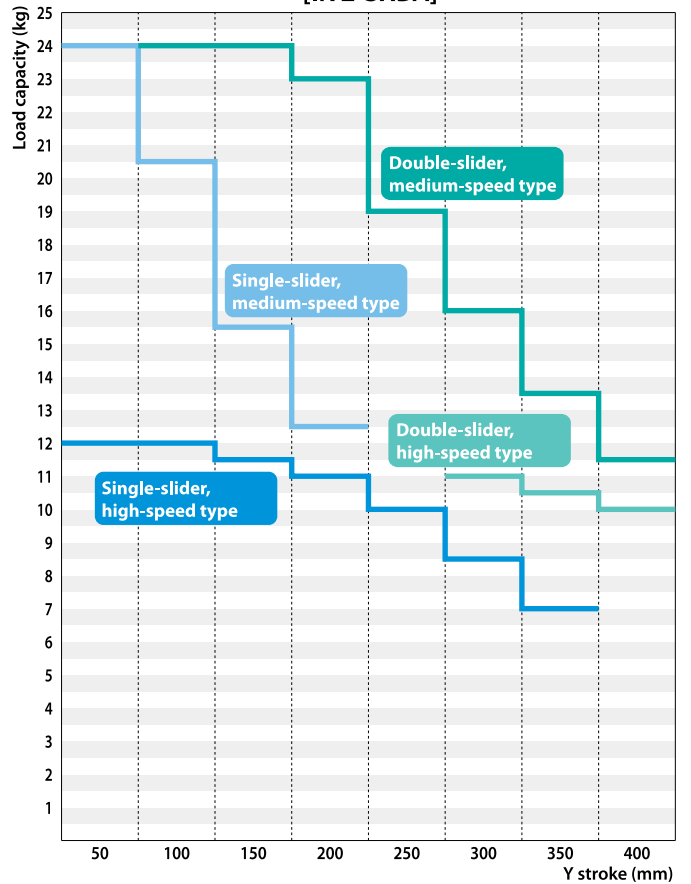

Combination Unit List for IK Series

RCP2 Combination Unit List for 2-axis Configuration (XYB) (□ in the model names indicates a value from 1 to 4 specifying the combination direction. For the combination directions, refer to P.10.)

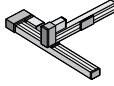
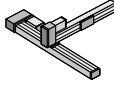
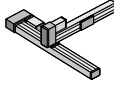
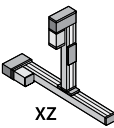
Page	Combination model	Combined shape	Axis 1				Axis 2				
			Type	Motor size	Lead (mm)	Maximum speed (mm/sec)	Stroke (mm)	Type			
13	IK2-PXBD1□HHS		SS7R Reversed	42□	12	400	50-600	SA5R Reversed			
	IK2-PXBD1□HMS				12	350					
15	IK2-PXBD1□HHD		SS7R Reversed, double-slider		12	400	50-450				
	IK2-PXBD1□HMD				12	350					
17	IK2-PXBD2□HHS		SS7C Straight		12	400	50-600				
	IK2-PXBD2□HMS				12	350					
19	IK2-PXBD2□HHD		SS7C Straight, double-slider		12	400	50-450				
	IK2-PXBD2□HMD				12	350					
21	IK2-PXBC1□HHS				SS7R Reversed	56□	12		400	50-600	SA6R Reversed
	IK2-PXBC1□HMS						12		250		
23	IK2-PXBC1□HHD				SS7R Reversed, double-slider		12		400	50-450	
	IK2-PXBC1□HMD						12		250		
25	IK2-PXBC2□HHS				SS7C Straight		12		400	50-600	
	IK2-PXBC2□HMS						12		250		
27	IK2-PXBC2□HHD				SS7C Straight, double-slider		12		400	50-450	
	IK2-PXBC2□HMD						12		250		
29	IK2-PXBB1□HHS						SS8R Reversed		56□	20	
	IK2-PXBB1□MMS	10		125							
31	IK2-PXBB1□HHD	SS8R Reversed, double-slider		20			250	50-800			
	IK2-PXBB1□MMD			10			125				
33	IK2-PXBB2□HHS	SS8C Straight		20			250	50-1000			
	IK2-PXBB2□MMS			10			125				
35	IK2-PXBB2□HHD	SS8C Straight, double-slider		20			250	50-800			
	IK2-PXBB2□MMD			10			125				
37	IK2-PXZB1□HHS			SS8R Reversed			56□	20		250	
	IK2-PXZB1□HMS		50-800								
39	IK2-PXZB1□HHD			SS8R Reversed, double-slider		50-800					
	IK2-PXZB1□HMD										
41	IK2-PYBB1□HHS		SS8R Reversed	50-1000							
	IK2-PYBB1□HMS										
	IK2-PYBB1□HLS										

RCS2 Combination Unit List for 2-axis Configuration (XYB) (□ in the model names indicates a value from 1 to 4 specifying the combination direction. For the combination directions, refer to P.10.)

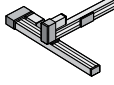
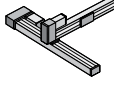
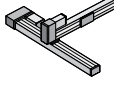
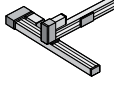
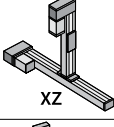
Page	Combination model	Combined shape	Axis 1				Axis 2				
			Type	Motor output (W)	Lead (mm)	Maximum speed (mm/sec)	Stroke (mm)	Type			
43	IK2-SXBD1□HHS		SS7R Reversed	60	12	600	50-600	SA5R Reversed			
	IK2-SXBD1□HMS				12	600					
45	IK2-SXBD1□HHD		SS7R Reversed, double-slider		12	600	50-450				
	IK2-SXBD1□HMD				12	600					
47	IK2-SXBD2□HHS		SS7C Straight		12	600	50-600				
	IK2-SXBD2□HMS				12	600					
49	IK2-SXBD2□HHD		SS7C Straight, double-slider		12	600	50-450				
	IK2-SXBD2□HMD				12	600					
51	IK2-SXBC1□HHS				SS7R Reversed	100	12		600	50-600	SA6R Reversed
	IK2-SXBC1□MMS						6		300		
53	IK2-SXBC1□HHD				SS7R Reversed, double-slider		12		600	50-450	
	IK2-SXBC1□MMD						6		300		
55	IK2-SXBC2□HHS				SS7C Straight		12		600	50-600	
	IK2-SXBC2□MMS						6		300		
57	IK2-SXBC2□HHD				SS7C Straight, double-slider		12		600	50-450	
	IK2-SXBC2□MMD						6		300		
59	IK2-SXBB1□HHS						SS8R (100W) Reversed		150	20	
	IK2-SXBB1□MMS	10		500							
61	IK2-SXBB1□HHD	SS8R (100W) Reversed, double-slider		20			1000	50-800			
	IK2-SXBB1□MMD			10			500				
63	IK2-SXBB2□HHS	SS8C (100W) Straight		20			1000	50-1000			
	IK2-SXBB2□MMS			10			500				
65	IK2-SXBB2□HHD	SS8C (100W) Straight, double-slider		20			1000	50-800			
	IK2-SXBB2□MMD			10			500				
67	IK2-SXBA1□HHS			SS8R (150W) Reversed			150	20		1000	
	IK2-SXBA1□MMS		10			500					
69	IK2-SXBA1□HHD		SS8R (150W) Reversed, double-slider	20		1000		50-800			
	IK2-SXBA1□MMD			10		500					
71	IK2-SXBA2□HHS		SS8C (150W) Straight	20		1000		50-1000			
	IK2-SXBA2□MMS			10		500					
73	IK2-SXBA2□HHD		SS8C (150W) Straight, double-slider	20		1000		50-800			
	IK2-SXBA2□MMD			10		500					
75	IK2-SXZB1□HHS			SS8R (100W) Reversed		100		20		1000	50-1000
	IK2-SXZB1□HMS				50-800						
77	IK2-SXZB1□HHD			SS8R (100W) Reversed, double-slider					50-800		
	IK2-SXZB1□HMD										
79	IK2-SYBB1□HHS			SS8R (100W) Reversed	50-1000						
	IK2-SYBB1□HMS										
	IK2-SYBB1□HLS										

		Axis 1: Mount axis	Axis 2: Axis installed on axis 1	Axis 3: Axis installed on axis 2	Cable wiring 1: Wiring for axis 2	Cable wiring 2: Wiring for axis 3							
		Axis 2			Load capacity by axis 2 stroke								
Motor size	Lead (mm)	Maximum speed (mm/sec)	Stroke (mm)	50	100	150	200	250	300	350	400		
42□	12	600	50-200	3.0	3.0	2.5	2.5						
	6	300	50-200	6.0	6.0	5.0	5.0						
	12	600	250-400					2.5	2.0	2.0	2.0		
	6	300	250-400					5.0	4.0	4.0	4.0		
	12	600	50-200	3.0	3.0	2.5	2.5						
	6	300	50-200	6.0	6.0	5.0	5.0						
42□	12	600	250-400					2.5	2.0	2.0	2.0		
	6	300	250-400					5.0	4.0	4.0	4.0		
	12	600	50-200	4.5	4.5	4.0	3.0						
	6	300	50-200	9.0	9.0	8.0	6.0						
	12	600	250-400					3.0	3.0	3.0	3.0		
	6	300	250-400					6.0	6.0	6.0	6.0		
56□	16	450	50-300	8.0	8.0	7.0	7.0	6.0	6.0				
	8	220	50-300	16.0	16.0	15.0	12.5	9.0	8.0				
	16	450	350-400							6.0	5.5		
	8	220	200-400				15.0	12.5	12.5	12.0	10.5		
	16	450	50-300	8.0	8.0	7.0	7.0	6.0	6.0				
	8	220	50-300	16.0	16.0	15.0	12.5	9.0	8.0				
56□	16	450	350-400							6.0	5.5		
	8	220	200-400				15.0	12.5	12.5	12.0	10.5		
	16	360	50-250	2.0	2.0	2.0	2.0	1.5					
	8	180	50-250	4.0	4.0	3.5	3.5	2.5					
	4	90	50-250	8.0	7.0	5.0	4.0	3.0					
	16	400	300						1.5				
56□	8	200	300						3.0				
	4	100	150-300			7.0	7.0	5.5	5.5				
	16	360	50-300	2.0	2.0	2.0	2.0	1.5	1.5				
	8	180	50-300	4.0	4.0	3.5	3.5	3.0	3.0				
	4	90	50-300	8.0	8.0	7.0	7.0	6.0	5.5				

		Axis 2			Load capacity by axis 2 stroke								
Motor output (W)	Lead (mm)	Maximum speed (mm/sec)	Stroke (mm)	50	100	150	200	250	300	350	400		
20	12	800	50-200	3.0	3.0	2.5	2.5						
	6	400		6.0	6.0	5.0	5.0						
	12	800	250-400					2.5	2.0	2.0	2.0		
	6	400						5.0	4.0	4.0	4.0		
	12	800	50-200	3.0	3.0	2.5	2.5						
	6	400		6.0	6.0	5.0	5.0						
30	12	800	250-400					2.5	2.0	2.0	2.0		
	6	400						5.0	4.0	4.0	4.0		
	12	800	50-200	4.5	4.5	4.0	3.0						
	6	400		9.0	9.0	8.0	6.0						
	12	800	250-400					3.0	3.0	3.0	3.0		
	6	400						6.0	6.0	6.0	6.0		
60	16	800	50-300	8.0	8.0	7.0	7.0	6.0	6.0				
	8	400		16.0	16.0	15.0	12.5	9.0	8.0				
	16	800	350-400							6.0	5.5		
	8	400	200-400				15.0	12.5	12.5	12.0	10.5		
	16	800	50-300	8.0	8.0	7.0	7.0	6.0	6.0				
	8	400		16.0	16.0	15.0	12.5	9.0	8.0				
100	16	800	350-400							6.0	5.5		
	8	400	200-400				15.0	12.5	12.5	12.0	10.5		
	20	1000	50-350	12.0	12.0	11.5	11.0	10.0	8.5	7.0			
	10	500		24.0	20.5	15.5	12.5						
	20	1000	300-400						11.0	10.5	10.0		
	10	500	100-400		24.0	24.0	23.0	19.0	16.0	13.5	11.5		
60	20	1000	50-350	12.0	12.0	11.5	11.0	10.0	8.5	7.0			
	10	500		24.0	20.5	15.5	12.5						
	20	1000	300-400						11.0	10.5	10.0		
	10	500	100-400		24.0	24.0	23.0	19.0	16.0	13.5	11.5		
	16	800	50-250	2.0	2.0	2.0	2.0	1.5					
	8	400		4.0	4.0	3.5	3.5	2.5					
4	200	300	8.0	7.0	5.0	4.0	3.0						
60	16	800	300						1.5				
	8	400							3.0				
	4	200	150-300			7.0	7.0	5.5	5.5				
	16	800	50-300	2.0	2.0	2.0	2.0	1.5	1.5				
	8	400		4.0	4.0	3.5	3.5	3.0	3.0				
	4	200	8.0	8.0	7.0	7.0	6.0	5.5					

RCP2 Combination Unit List for 3-axis Configuration (XYB+Z-axes, base mount) (□ in the model names indicates a value from 1 to 4 specifying the combination direction. For the combination directions, refer to P. 10.)

Page	Combination model	Combined shape	X axis				Y axis	
			Type	Motor size	Lead (mm)	Maximum speed (mm/sec)	Stroke (mm)	Type
81	IK3-PBBG1□HHHS	XYB+Z, base mount	SS8R Reversed, single-slider	56□	20	220	50-1000	SA7R Reversed
	IK3-PBBG1□HHMS							
	IK3-PBBG1□HHLS							
83	IK3-PBBG1□HHHD		SS8R Reversed, double-slider				50-800	
	IK3-PBBG1□HHMD							
	IK3-PBBG1□HHL D							

RCS2 Combination Unit List for 3-axis Configuration (XYB+Z-axes, base mount) (□ in the model names indicates a value from 1 to 4 specifying the combination direction. For the combination directions, refer to P. 10.)

Page	Combination model	Combined shape	X axis				Y axis	
			Type	Motor output (W)	Lead (mm)	Maximum speed (mm/sec)	Stroke (mm)	Type
85	IK3-SBBG1□HHHS	XYB+Z, base mount	SS8R (100W) Reversed, single-slider	100	20	1000	50-1000	SA7R Reversed
	IK3-SBBG1□HHMS							
	IK3-SBBG1□HHLS							
88	IK3-SBBG1□HHHD		SS8R (100W) Reversed, double-slider				50-800	
	IK3-SBBG1□HHMD							
	IK3-SBBG1□HHL D							

Tips on Selection

1. Differences between RCP2 and RCS2

Features of RCP2

- [1] Adopting a pulse motor.
- [2] Characterized by high thrust at low speed.
- [3] Less expensive than the RCS2.



Features of RCS2

- [1] Adopting a servo motor.
- [2] Able to operate at a constant thrust regardless of the speed.
- [3] Able to move at higher speeds than the RCP2.

2. Differences between X-axis Straight and Reversed Types

The X-axis reversed type can have a shorter dimension in the X-axis direction. When the 150-watt RCS2-SS8C (straight) and 150-watt SS8R (reversed) are compared, for example, the SS8R is shorter by 130 mm. Note, however, that the reversed type does not support configurations based on combination directions [3] and [4].

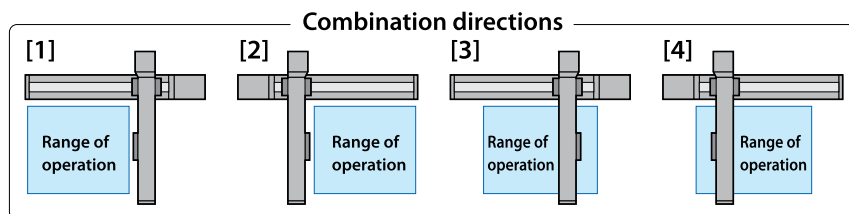
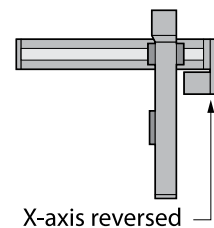
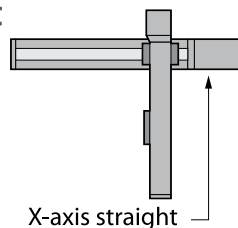

3. Differences between Single-slider and Double-slider Types

A double-slider consists of two sliders connected to each other and has a greater permissible load moment compared to a single-slider type. Accordingly, double-slider units are used as the X-axis in XY configurations with a long overhang. Note, however, that because the double-slider structure naturally has a longer slider section, a double-slider unit has a shorter stroke than a single-slider unit of the same total length.

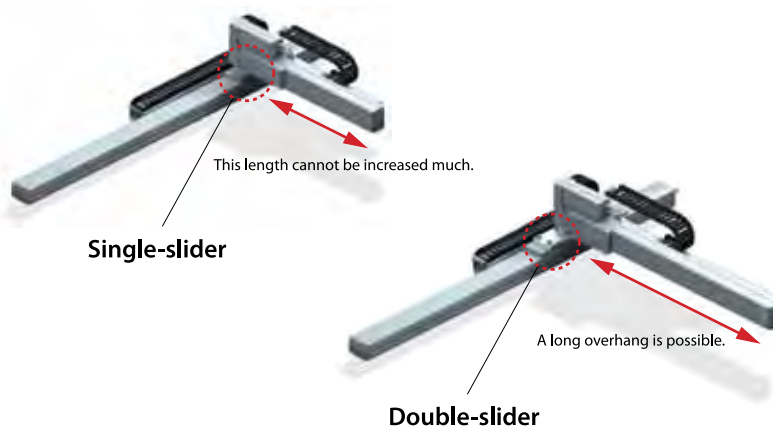

Controller List

The IA kit supports the following controllers. For details on each controller, refer to the reference page describing the applicable controller.

	Exterior view	Features	Maximum number of positioning points	Input power supply	Reference page
PCON		A positioning controller for the RCP2 series. Pulse-train control and serial communication types are also available.	512	DC24V	Refer to the ROBO Cylinder General Catalog
PSEL		A program controller for the RCP2 series. Can be programmed using SEL language. 1-axis and 2-axis types are available.	1500	DC24V	P. 93
SCON		A positioning controller for the RCS2 series. Field networks are supported.	512	100 VAC Single-phase 200 VAC	Refer to the ROBO Cylinder General Catalog
SSEL		A program controller for the RCS2 series. Can be programmed using SEL language. 1-axis and 2-axis types are available.	1500	100 VAC Single-phase 200 VAC	P. 93
ROBONET		Able to operate 1 to 16 ROBO Cylinder axes via a field network. Less hassle of wiring and installation.	768	DC24V	P. 93
XSEL-J/K		For the RCS2 series. 3-axis and 4-axis configurations are supported. Two sets of 2-axis combination systems can be controlled. J type: Small size K type: Provides greater expandability because I/Os can be used.	3000	100 VAC Single-phase 200 VAC	P. 93
XSEL-P/Q		For the RCS2 series. 5-axis and 6-axis configurations are supported.	4000	Three-phase 200 VAC	P. 93



OVER 30 YEARS OF IAI!

ESTABLISHED IN 1976, IAI HAS GROWN GLOBALLY TO SERVE OVER 12 COUNTRIES. IAI HAS 24 REGIONAL OFFICES IN JAPAN AND IS PROUD TO ANNOUNCE A NEWLY CONSTRUCTED HEADQUARTERS, WITH AN ADJACENT STATE OF THE ART MANUFACTURING FACILITY TO PRODUCE THE HIGHEST QUALITY AUTOMATION ROBOTS. IAI IS CONSTANTLY STRIVING IN THE PURSUIT OF 'QUALITY AND INNOVATION.' OUR FOCUS IS ALWAYS ON THE NEEDS OF OUR CUSTOMERS AND TO OFFER HIGH QUALITY AND INNOVATIVE SOLUTIONS TAILORED FOR SPECIFIC CUSTOMER APPLICATIONS. IAI AMERICA INC. WAS ESTABLISHED IN 1989 TO BETTER SERVE THE NEEDS OF FACTORY AUTOMATION. WITH 3 MAIN OFFICES IN THE UNITED STATES, SUPPORT IS ALWAYS A PHONE CALL AWAY WHERE YOU CAN REACH EXPERIENCED TECHNICAL SUPPORT ENGINEERS.

FROM OUR EASY TO USE SOFTWARE, TO COMPLETE AUTOMATION SOLUTIONS, WE PROVIDE YOU WITH THE TOOLS NECESSARY TO SCALE YOUR BUSINESS. WHEN YOU DEMAND INNOVATIVE AND HIGH QUALITY ROBOTS, EXCELLENT SERVICE AND SUPPORT FOR YOUR UNIQUE NEEDS, DEMAND IAI!



IAI Headquarters
 On the windows of the newly constructed headquarters spell out the character for 'heart' in Japanese. This character is rich and meaningful, symbolizing the heart, spirit, attention and sincerity of IAI's commitment to the users of IAI products.

ISO 9001:2000
 IAI has been certified for ISO 9001:2000 and JIS Q9001:2000 by an independent auditor to be in conformance with ISO 9001:2000 and JIS 9001:2000. We at IAI are continually improving our methods to produce quality products and services that surpass customer expectations.



RoHS Compliant
 IAI is RoHS compliant and recognizes the responsibility in reducing hazardous substances to better serve our customers and our environment.



IK2-PXBD1□□S

RCP2 2-axis Combinations X axis: SS7R (Reversed, Single-slider)
Y axis: SA5R (Reversed)

Model Details

Series: IK2 — Type: PXBD1□□S — Encoder type: I: Incremental — Axis 1 (X axis): □ — Axis 2 (Y axis): □ — Controllers: P1 — Cable: □ — Shipping configuration: □

Combination directions 1-2
Differences between Single-slider and Double-slider Types
HH: X high-speed, Y high-speed
HM: X high-speed, Y medium-speed

Encoder type I: Incremental

Stroke (mm)
5: 50mm
(Can be set in 50-mm increments)

Options
NM: Opposite-home specification
SR: Slider roller specification

Cable length
1L: 1m
3L: 3m
5L: 5m
□L: □m

Wiring 1
N: Cable only

Wiring 2
CT: With cable track

Shipping configuration
K: Individual components (kit)

* Refer to P.10 for details on the items comprising the model name.

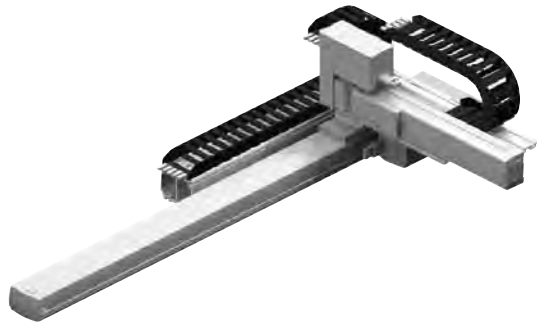

Both wiring 1 and wiring 2 assume use of a cable track.

Maximum Stroke

X axis 600 mm

Y axis 200 mm

Maximum Speed (High-speed type)

X axis 400 mm/s

Y axis 600 mm/s

Maximum Load Capacity

Y-axis stroke	X high-speed, Y high-speed	X high-speed, Y medium-speed
50mm	3.0kg	6.0kg
100mm	3.0kg	6.0kg
150mm	2.5kg	5.0kg
200mm	2.5kg	5.0kg

List of Options

Name	Option code
Opposite-home specification	NM
Slider roller specification	SR

Specifications

Item	X axis	Y axis
Axis model	RCP2-SS7R	RCP2-SA5R
Stroke (Can be set in 50-mm increments)	50-600mm	50-200mm
Max speed	HH type: 400mm/s HM type: 350mm/s	High-speed type: 600mm/s Medium-speed type: 300mm/s
Motor size	42-square pulse motor	
Ball screw lead	High-speed type: 12mm	High-speed type: 12mm Medium-speed type: 6mm
Drive method	Ball screw, ø10 mm, rolled, C10	
Positioning repeatability	±0.02mm	
Base material	Dedicated alloy steel	Aluminum
Surrounding air temperature/humidity	0 to 40°C, 85% RH or below (non-condensing)	

Dimensions

You can download CAD drawings from our website.

www.intelligentactuator.com

2D CAD

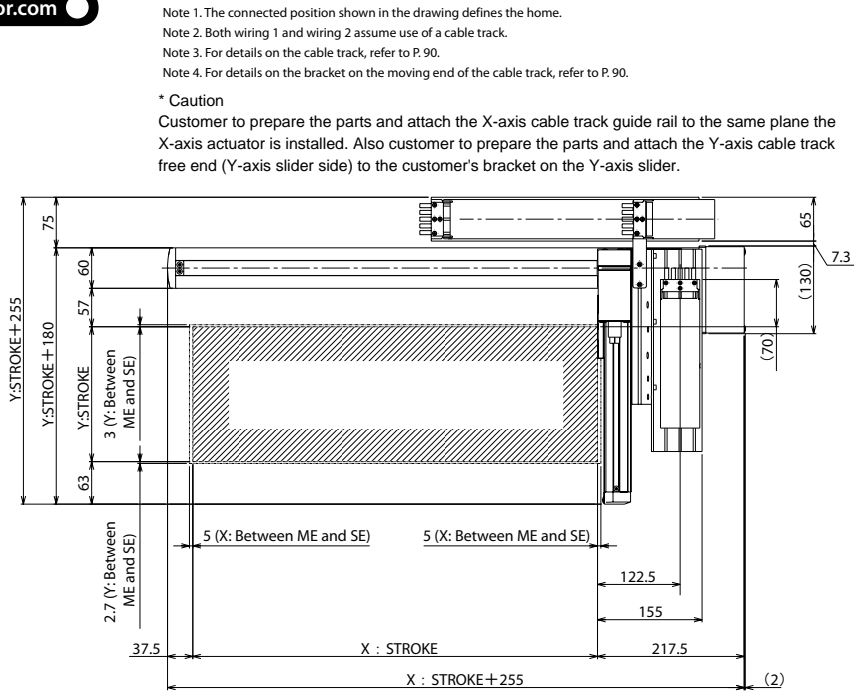
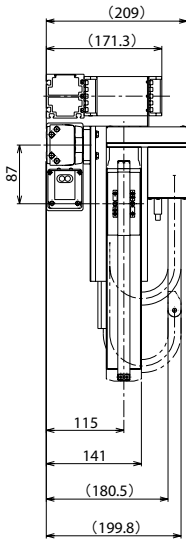

Note 1. The connected position shown in the drawing defines the home.
 Note 2. Both wiring 1 and wiring 2 assume use of a cable track.
 Note 3. For details on the cable track, refer to P. 90.
 Note 4. For details on the bracket on the moving end of the cable track, refer to P. 90.

* Caution

Customer to prepare the parts and attach the X-axis cable track guide rail to the same plane the X-axis actuator is installed. Also customer to prepare the parts and attach the Y-axis cable track free end (Y-axis slider side) to the customer's bracket on the Y-axis slider.

ME: Mechanical end
 SE: Stroke end

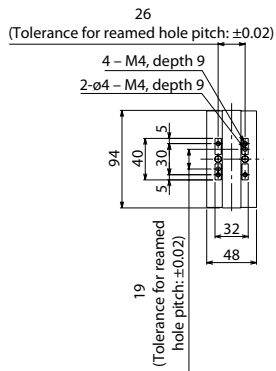
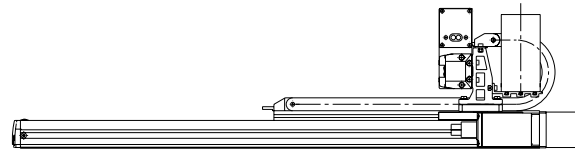

Detail view of Y-axis slider

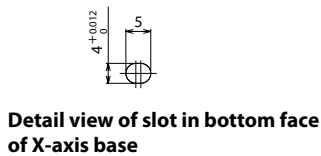

Detail view of slot in bottom face of X-axis base

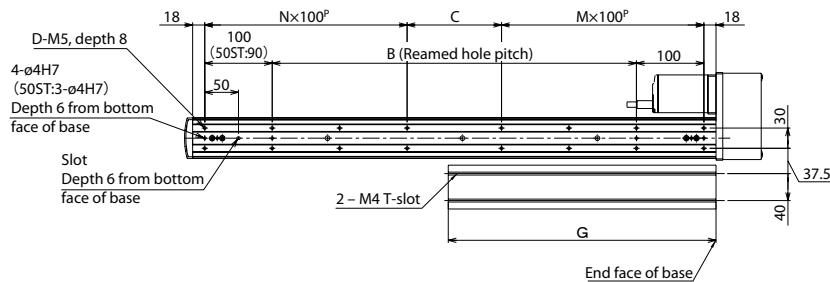

■ Dimensions by Stroke

Detail view of X-axis installation

X: Model	50	100	150	200	250	300	350	400	450	500	550	600
B	0	40	90	140	190	240	290	340	390	440	490	540
C	90	40	90	140	190	40	90	140	190	40	90	140
D	6	8	8	8	8	12	12	12	12	16	16	16
M	1	1	1	1	1	2	2	2	2	3	3	3
N	0	1	1	1	1	2	2	2	2	3	3	3
G	122	147	172	197	222	247	272	297	322	347	372	397

Controllers

Applicable controller



Refer to P. 91 for the controllers.

IK2-PXBD1□□D

RCP2 2-axis Combinations X axis: SS7R (Reversed, Double-slider)
Y axis: SA5R (Reversed)

Model Details Series **IK2** Type **PXBD1□□D** Encoder type **I** Axis 1 (X axis) **□** Axis 2 (Y axis) **□** Controllers **P1** Cable **□** Shipping configuration **□**

Combination directions 1-2

Differences between Single-slider and Double-slider Types
HH: X high-speed, Y high-speed
HM: X high-speed, Y medium-speed

Encoder type
I: Incremental

Stroke (mm)
5: 50mm
? (Can be set in 50-mm increments)

Options
NM: Opposite-home specification
SR: Slider roller specification

Cable length
1L: 1m
3L: 3m
5L: 5m
□L: □m

Wiring 1
N: Cable only

Wiring 2
CT: With cable track

Shipping configuration
K: Individual components (kit)

* Refer to P.10 for details on the items comprising the model name.

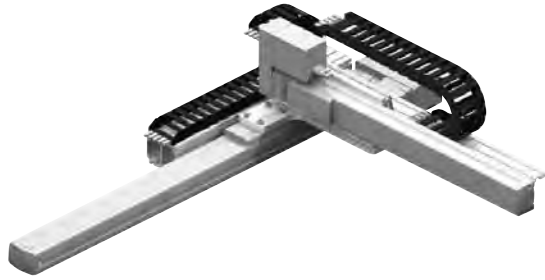

Maximum Stroke

X axis 450 mm

Y axis 400 mm

Maximum Speed (High-speed type)

X axis 400 mm/s

Y axis 600 mm/s

Maximum Load Capacity

Y-axis stroke	X high-speed, Y high-speed	X high-speed, Y medium-speed
250mm	2.5kg	5.0kg
300mm	2.0kg	4.0kg
350mm	2.0kg	4.0kg
400mm	2.0kg	4.0kg

Both wiring 1 and wiring 2 assume use of a cable track.

List by Stroke

		Incremental			
Y-axis stroke		250	300	350	400
X-axis stroke	50	-	-	-	-
	100	-	-	-	-
	150	-	-	-	-
	200	-	-	-	-
	250	-	-	-	-
	300	-	-	-	-
	350	-	-	-	-
	400	-	-	-	-
	450	-	-	-	-

Cable track

Wiring 1 (Next to X-axis)	X-axis stroke	50-300	350-450
		-	-
Wiring 2 (Next to Y-axis)	Y-axis stroke	250-400	-
		-	-

List by Cable Length

Type	Cable code	Length
Standard type	1L	1m
	3L	3m
	5L	5m

* Axis 1 comes with a standard cable, while axis 2 comes with a robot cable.

* Refer to P. 90 for lengths other than those specified above.

List of Options

Name	Option code	-
Opposite-home specification	NM	-
Slider roller specification	SR	Axis 1 (X-axis) Axis 2 (Y-axis)

Specifications

Item	X axis	Y axis
Axis model	RCP2-SS7R	RCP2-SA5R
Stroke (Can be set in 50-mm increments)	50-450mm	250-400mm
Max speed	HH type: 400mm/s HM type: 350mm/s	High-speed type: 600mm/s Medium-speed type: 300mm/s
Motor size	42-square pulse motor	
Ball screw lead	High-speed type: 12mm	High-speed type: 12mm Medium-speed type: 6mm
Drive method	Ball screw, ø10 mm, rolled, C10	
Positioning repeatability	±0.02mm	
Base material	Dedicated alloy steel	Aluminum
Surrounding air temperature/humidity	0 to 40°C, 85% RH or below (non-condensing)	

Dimensions

You can download CAD drawings from our website.

www.intelligentactuator.com

2D CAD

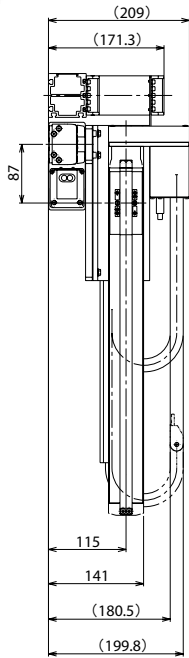

26
(Tolerance for reamed hole pitch: ±0.02)

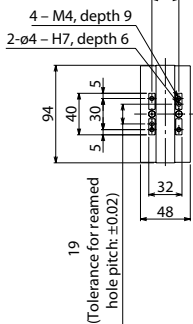

Detail view of Y-axis slider



Detail view of slot in bottom face of X-axis base

Note 1. The connected position shown in the drawing defines the home.
Note 2. Both wiring 1 and wiring 2 assume use of a cable track.
Note 3. For details on the cable track, refer to P. 90.
Note 4. For details on the bracket on the moving end of the cable track, refer to P. 90.

* Caution

Customer to prepare the parts and attach the X-axis cable track guide rail to the same plane the X-axis actuator is installed. Also customer to prepare the parts and attach the Y-axis cable track free end (Y-axis slider side) to the customer's bracket on the Y-axis slider.

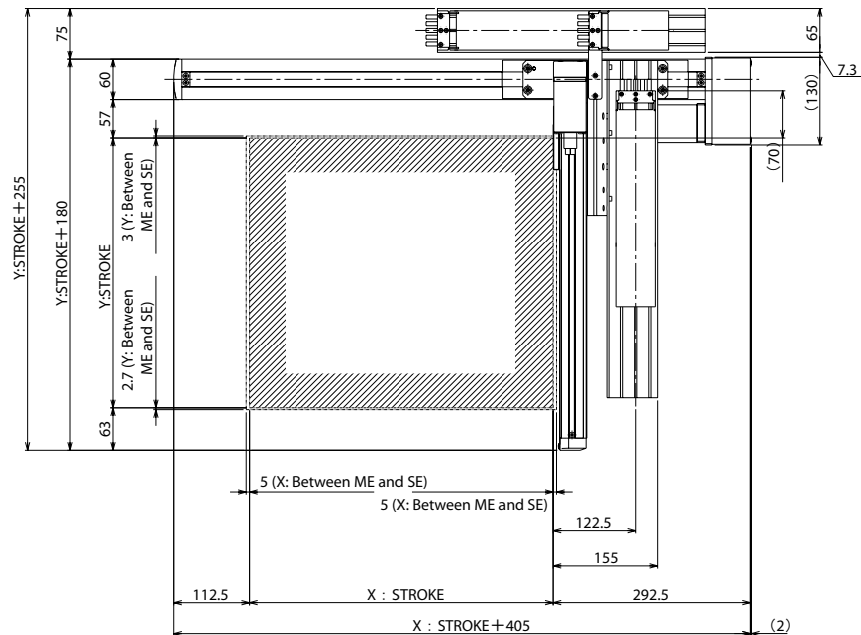

ME: Mechanical end
SE: Stroke end

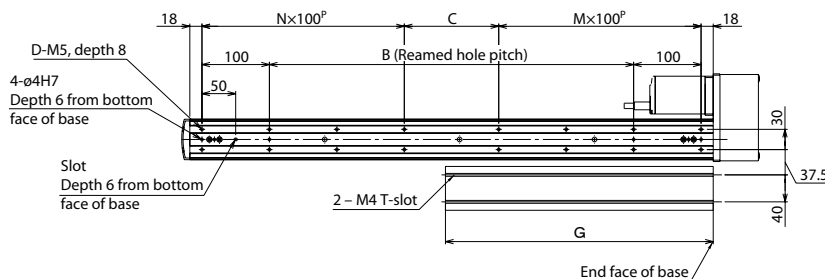
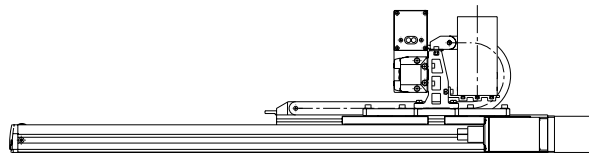

Detail view of X-axis installation

■ Dimensions by Stroke

X: Nominal stroke	200	250	300	350	400	450	500	550	600
X: Effective stroke	50	100	150	200	250	300	350	400	450
B	140	190	240	290	340	390	440	490	540
C	140	190	40	90	140	190	40	90	140
D	8	8	12	12	12	12	16	16	16
M	1	1	2	2	2	2	3	3	3
N	1	1	2	2	2	2	3	3	3
G	197	222	247	272	297	322	347	372	397

Controllers

Applicable controller



Refer to P. 91 for the controllers.

IK2-PXBD2□□S

RCP2 2-axis Combinations X axis: SS7C (Straight, Single-slider)
Y axis: SA5R (Reversed)

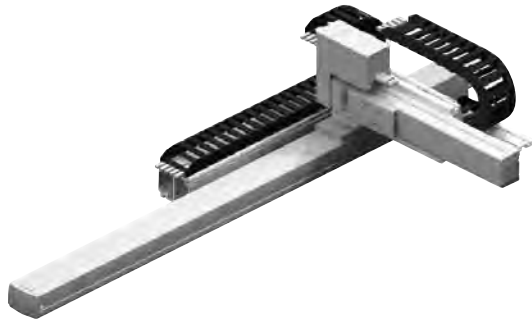
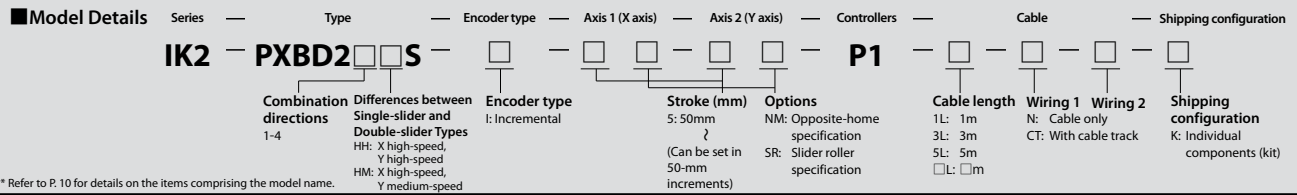

Maximum Stroke

X axis 600 mm

Y axis 200 mm

Maximum Speed (High-speed type)

X axis 400 mm/s

Y axis 600 mm/s

Maximum Load Capacity

Y-axis stroke	X high-speed, Y high-speed	X high-speed, Y medium-speed
50mm	3.0kg	6.0kg
100mm	3.0kg	6.0kg
150mm	2.5kg	5.0kg
200mm	2.5kg	5.0kg

Both wiring 1 and wiring 2 assume use of a cable track.

List by Stroke

		Incremental			
Y-axis stroke		50	100	150	200
X-axis stroke	50	-	-	-	-
	100	-	-	-	-
	150	-	-	-	-
	200	-	-	-	-
	250	-	-	-	-
	300	-	-	-	-
	350	-	-	-	-
	400	-	-	-	-
	450	-	-	-	-
	500	-	-	-	-
	550	-	-	-	-
600	-	-	-	-	

Cable track

	X-axis stroke	50-300	350-600
Wiring 1 (Next to X-axis)	Y-axis stroke	-	-
Wiring 2 (Next to Y-axis)	Y-axis stroke	50-200	-
		-	-

List of Options

Name	Option code	
Opposite-home specification	NM	
Slider roller specification	SR	Axis 1 (X-axis) Axis 2 (Y-axis)

List by Cable Length

Type	Cable code	Length
Standard type	1L	1m
	3L	3m
	5L	5m

* Axis 1 comes with a standard cable, while axis 2 comes with a robot cable.

* Refer to P.90 for lengths other than those specified above.

Specifications

Item	X axis	Y axis
Axis model	RCP2-SS7C	RCP2-SA5R
Stroke (Can be set in 50-mm increments)	50-600mm	50-200mm
Max speed	HH type: 400mm/s HM type: 350mm/s	High-speed type: 600mm/s Medium-speed type: 300mm/s
Motor size	42-square pulse motor	
Ball screw lead	High-speed type: 12mm	High-speed type: 12mm Medium-speed type: 6mm
Drive method	Ball screw, ø10 mm, rolled, C10	
Positioning repeatability	±0.02mm	
Base material	Dedicated alloy steel	Aluminum
Surrounding air temperature/humidity	0 to 40°C, 85% RH or below (non-condensing)	

Dimensions

You can download CAD drawings from our website.

www.intelligentactuator.com

2D CAD

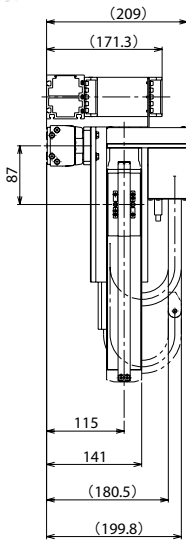

Note 1. The connected position shown in the drawing defines the home.
 Note 2. Both wiring 1 and wiring 2 assume use of a cable track.
 Note 3. For details on the cable track, refer to P.90.
 Note 4. For details on the bracket on the moving end of the cable track, refer to P.90.

* Caution

Customer to prepare the parts and attach the X-axis cable track guide rail to the same plane the X-axis actuator is installed. Also customer to prepare the parts and attach the Y-axis cable track free end (Y-axis slider side) to the customer's bracket on the Y-axis slider.

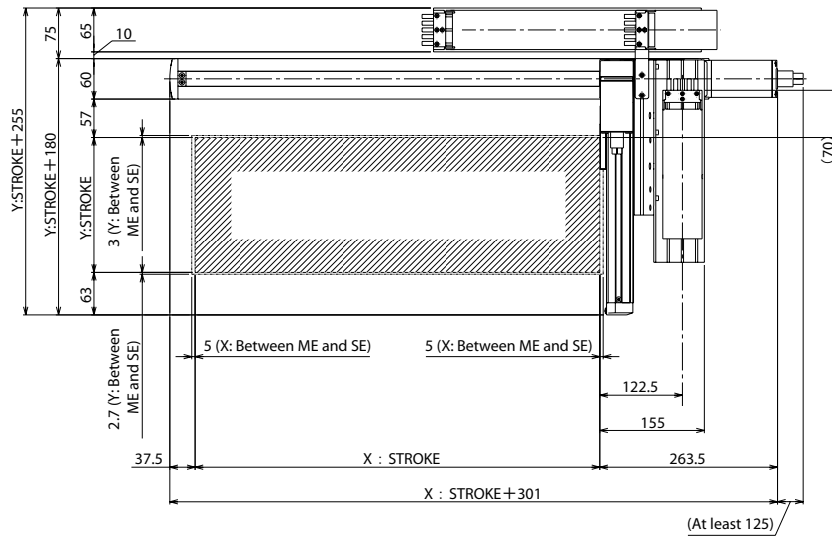

ME: Mechanical end
 SE: Stroke end

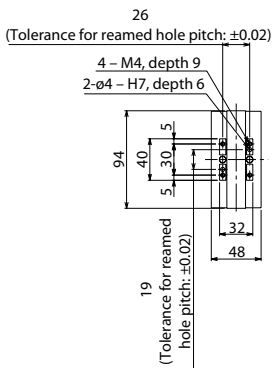
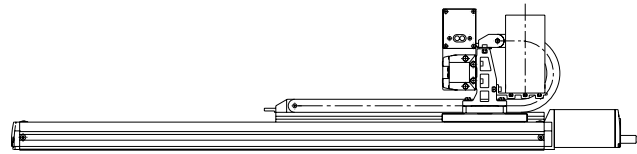

Detail view of Y-axis slider



Detail view of slot in bottom face of X-axis base

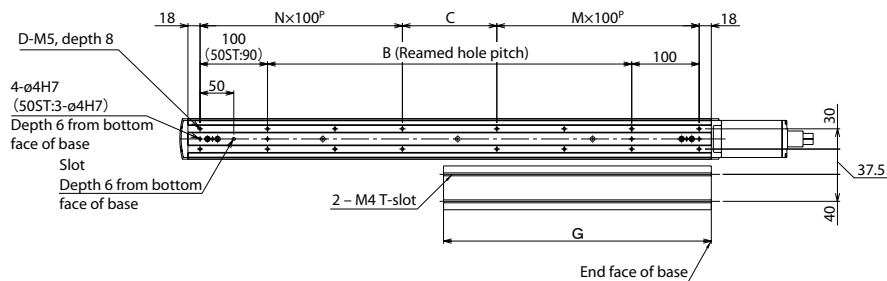

Detail view of X-axis installation

■ Dimensions by Stroke

X: Model	50	100	150	200	250	300	350	400	450	500	550	600
B	0	40	90	140	190	240	290	340	390	440	490	540
C	90	40	90	140	190	40	90	140	190	40	90	140
D	6	8	8	8	8	12	12	12	12	16	16	16
M	1	1	1	1	1	2	2	2	2	3	3	3
N	0	1	1	1	1	2	2	2	2	3	3	3
G	122	147	172	197	222	247	272	297	322	347	372	397

Controllers

Applicable controller



Refer to P. 91 for the controllers.

IK2-PXBD2□□D

RCP2 2-axis Combinations X axis: SS7C (Straight, Double-slider)
Y axis: SA5R (Reversed)

Model Details Series **IK2** Type **PXBD2□□D** Encoder type **I** Axis 1 (X axis) **□** Axis 2 (Y axis) **□** Controllers **P1** Cable **□** Shipping configuration **□**

Combination directions 1-4

Differences between Single-slider and Double-slider Types
HH: X high-speed, Y high-speed
HM: X high-speed, Y medium-speed

Encoder type
I: Incremental

Stroke (mm)
5: 50mm
? (Can be set in 50-mm increments)

Options
NM: Opposite-home specification
SR: Slider roller specification

Cable length
1L: 1m
3L: 3m
5L: 5m
□L: □m

Wiring 1
N: Cable only

Wiring 2
CT: With cable track

Shipping configuration
K: Individual components (kit)

* Refer to P.10 for details on the items comprising the model name.

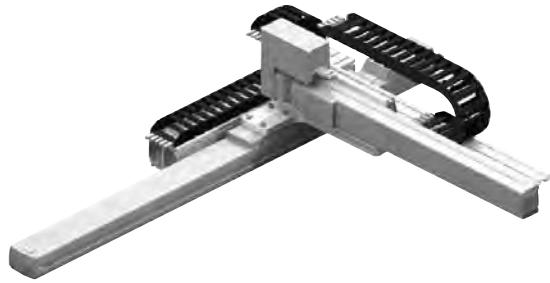

Maximum Stroke

X axis 450 mm

Y axis 400 mm

Maximum Speed (High-speed type)

X axis 400 mm/s

Y axis 600 mm/s

Maximum Load Capacity

Y-axis stroke	X high-speed, Y high-speed	X high-speed, Y medium-speed
250mm	2.5kg	5.0kg
300mm	2.0kg	4.0kg
350mm	2.0kg	4.0kg
400mm	2.0kg	4.0kg

Both wiring 1 and wiring 2 assume use of a cable track.

List by Stroke

		Incremental			
Y-axis stroke		250	300	350	400
X-axis stroke	50	-	-	-	-
	100	-	-	-	-
	150	-	-	-	-
	200	-	-	-	-
	250	-	-	-	-
	300	-	-	-	-
	350	-	-	-	-
	400	-	-	-	-
	450	-	-	-	-

List by Cable Length

Type	Cable code	Length
Standard type	1L	1m
	3L	3m
	5L	5m

* Axis 1 comes with a standard cable, while axis 2 comes with a robot cable.

* Refer to P. 90 for lengths other than those specified above.

Cable track

Wiring 1 (Next to X-axis)	X-axis stroke	50-300	350-450
		-	-
Wiring 2 (Next to Y-axis)	Y-axis stroke	250-400	-
		-	-

List of Options

Name	Option code	
Opposite-home specification	NM	
Slider roller specification	SR	Axis 1 (X-axis) Axis 2 (Y-axis)

Specifications

Item	X axis	Y axis
Axis model	RCP2-SS7C	RCP2-SA5R
Stroke (Can be set in 50-mm increments)	50-450mm	250-400mm
Max speed	HH type: 400mm/s HM type: 350mm/s	High-speed type: 600mm/s Medium-speed type: 300mm/s
Motor size	42-square pulse motor	
Ball screw lead	High-speed type: 12mm	High-speed type: 12mm Medium-speed type: 6mm
Drive method	Ball screw, ø10 mm, rolled, C10	
Positioning repeatability	±0.02mm	
Base material	Dedicated alloy steel	Aluminum
Surrounding air temperature/humidity	0 to 40°C, 85% RH or below (non-condensing)	

Dimensions

You can download CAD drawings from our website.

www.intelligentactuator.com

2D CAD

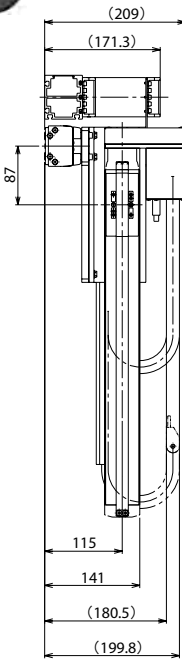

Note 1. The connected position shown in the drawing defines the home.
 Note 2. Both wiring 1 and wiring 2 assume use of a cable track.
 Note 3. For details on the cable track, refer to P. 90.
 Note 4. For details on the bracket on the moving end of the cable track, refer to P. 90.
 * Caution

Customer to prepare the parts and attach the X-axis cable track guide rail to the same plane the X-axis actuator is installed. Also customer to prepare the parts and attach the Y-axis cable track free end (Y-axis slider side) to the customer's bracket on the Y-axis slider.

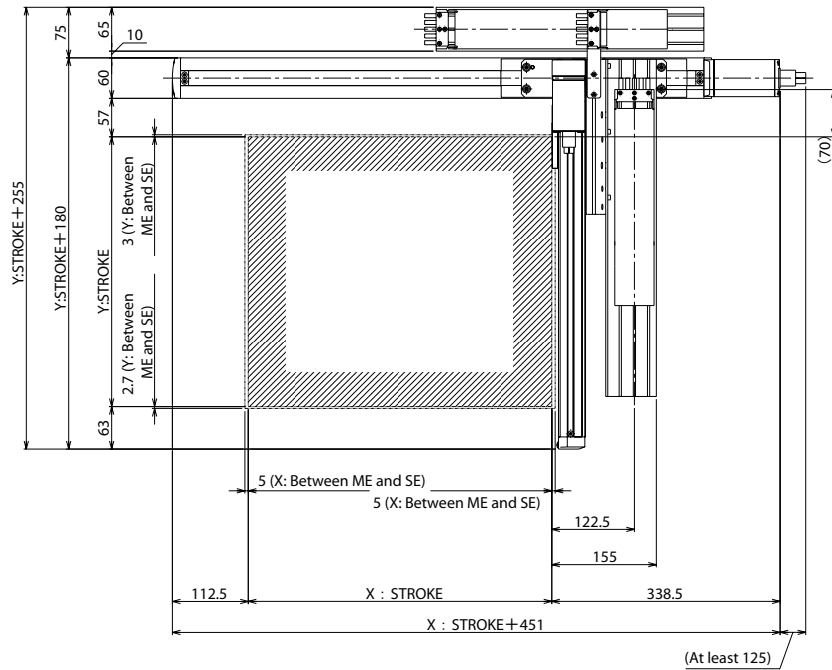

26
 (Tolerance for reamed hole pitch: ±0.02)

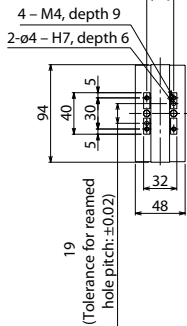

Detail view of Y-axis slider



Detail view of slot in bottom face of X-axis base

ME: Mechanical end
 SE: Stroke end

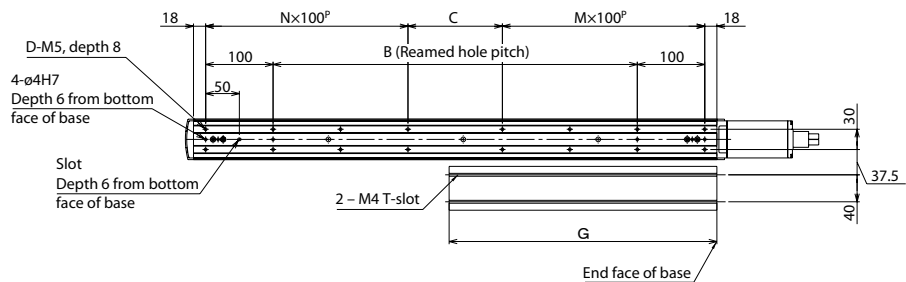
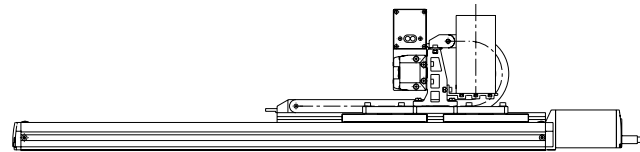

Detail view of X-axis installation

Dimensions by Stroke

X: Nominal stroke	200	250	300	350	400	450	500	550	600
X: Effective stroke	50	100	150	200	250	300	350	400	450
B	140	190	240	290	340	390	440	490	540
C	140	190	40	90	140	190	40	90	140
D	8	8	12	12	12	12	16	16	16
M	1	1	2	2	2	2	3	3	3
N	1	1	2	2	2	2	3	3	3
G	197	222	247	272	297	322	347	372	397

Controllers

Applicable controller



Refer to P. 91 for the controllers.

IK2-PXBC1□□S

RCP2 2-axis Combinations X axis: SS7R (Reversed, Single-slider)
Y axis: SASR (Reversed)

Model Details Series **IK2** Type **PXBC1□□S** Encoder type **I** Axis 1 (X axis) **□** Axis 2 (Y axis) **□** Controllers **P1** Cable **□** Shipping configuration **□**

Combination directions 1-2

Differences between Single-slider and Double-slider Types
HH: X high-speed, Y high-speed
HM: X high-speed, Y medium-speed

Encoder type I: Incremental

Stroke (mm)
5: 50mm
? (Can be set in 50-mm increments)

Options
NM: Opposite-home specification
SR: Slider roller specification

Cable length
1L: 1m
3L: 3m
5L: 5m
□L: □m

Wiring 1 N: Cable only
Wiring 2 CT: With cable track

Shipping configuration K: Individual components (kit)

* Refer to P.10 for details on the items comprising the model name.

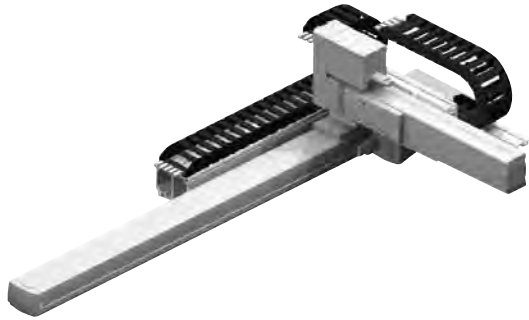

Maximum Stroke

X axis 600 mm

Y axis 200 mm

Maximum Speed (High-speed type)

X axis 400 mm/s

Y axis 600 mm/s

Maximum Load Capacity

Y-axis stroke	X high-speed, Y high-speed	X high-speed, Y medium-speed
50mm	4.5kg	9.0kg
100mm	4.5kg	9.0kg
150mm	4.0kg	8.0kg
200mm	3.0kg	6.0kg

Both wiring 1 and wiring 2 assume use of a cable track.

List by Stroke

		Incremental			
Y-axis stroke		50	100	150	200
X-axis stroke	50	-	-	-	-
	100	-	-	-	-
	150	-	-	-	-
	200	-	-	-	-
	250	-	-	-	-
	300	-	-	-	-
	350	-	-	-	-
	400	-	-	-	-
	450	-	-	-	-
	500	-	-	-	-
	550	-	-	-	-
600	-	-	-	-	

Cable track

Wiring 1 (Next to X-axis)	X-axis stroke	50-300	350-600
			-
Wiring 2 (Next to Y-axis)	Y-axis stroke	50-200	-
			-

List of by Cable Length

Type	Cable code	Length
Standard type	1L	1m
	3L	3m
	5L	5m

* Axis 1 comes with a standard cable, while axis 2 comes with a robot cable.

* Refer to P.90 for lengths other than those specified above.

List of Options

Name	Option code	
Opposite-home specification	NM	
Slider roller specification	SR	Axis 1 (X-axis) Axis 2 (Y-axis)

Specifications

Item	X axis	Y axis
Axis model	RCP2-SS7R	RCP2-SA6R
Stroke (Can be set in 50-mm increments)	50-600mm	50-200mm
Max speed	HH type: 400mm/s HM type: 250mm/s	High-speed type: 600mm/s Medium-speed type: 300mm/s
Motor size	42-square pulse motor	
Ball screw lead	High-speed type: 12mm	High-speed type: 12mm Medium-speed type: 6mm
Drive method	Ball screw, ø10 mm, rolled, C10	
Positioning repeatability	±0.02mm	
Base material	Dedicated alloy steel	Aluminum
Surrounding air temperature/humidity	0 to 40°C, 85% RH or below (non-condensing)	

Dimensions

You can download CAD drawings from our website.

www.intelligentactuator.com

2D CAD

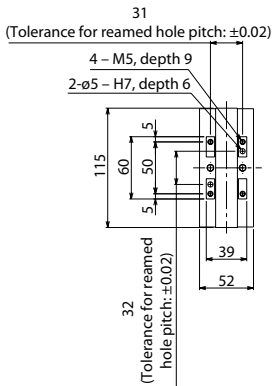
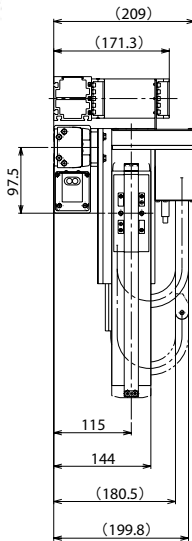

Detail view of Y-axis slider

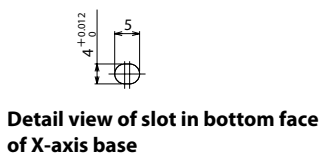

Detail view of slot in bottom face of X-axis base

- Note 1. The connected position shown in the drawing defines the home.
- Note 2. Both wiring 1 and wiring 2 assume use of a cable track.
- Note 3. For details on the cable track, refer to P.90.
- Note 4. For details on the bracket on the moving end of the cable track, refer to P.90.

* Caution

Customer to prepare the parts and attach the X-axis cable track guide rail to the same plane the X-axis actuator is installed. Also customer to prepare the parts and attach the Y-axis cable track free end (Y-axis slider side) to the customer's bracket on the Y-axis slider.

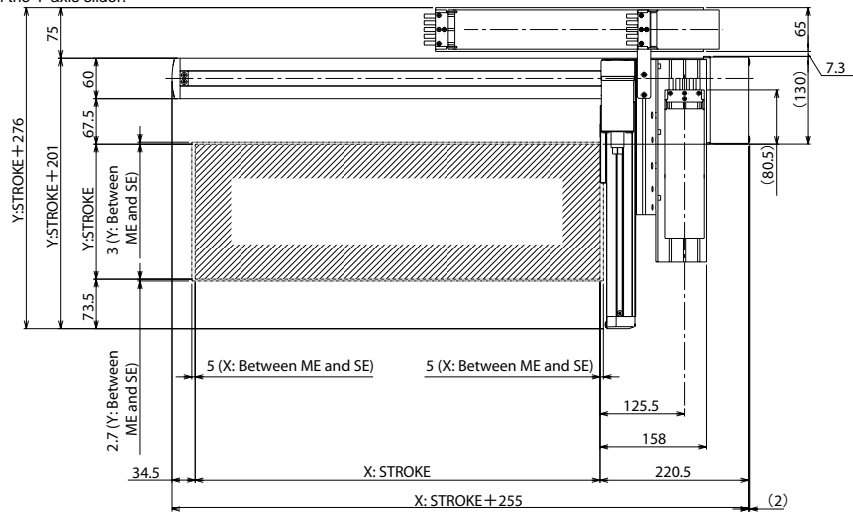

ME: Mechanical end
SE: Stroke end

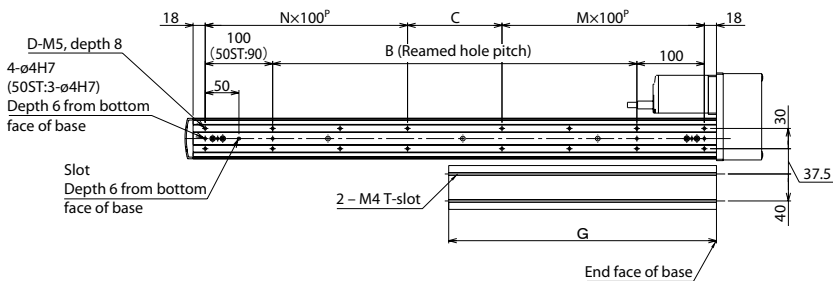
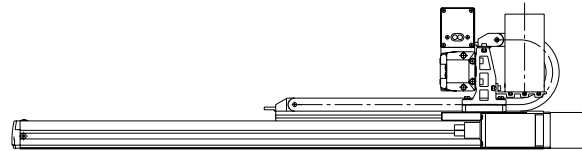

Detail view of X-axis installation

■ Dimensions by Stroke

X: Model	50	100	150	200	250	300	350	400	450	500	550	600
B	0	40	90	140	190	240	290	340	390	440	490	540
C	90	40	90	140	190	40	90	140	190	40	90	140
D	6	8	8	8	8	12	12	12	12	16	16	16
M	1	1	1	1	1	2	2	2	2	3	3	3
N	0	1	1	1	1	2	2	2	2	3	3	3
G	122	147	172	197	222	247	272	297	322	347	372	397

Controllers

Applicable controller



Refer to P. 91 for the controllers.

IK2-PXBC1□□D

RCP2 2-axis Combinations X axis: SS7R (Reversed, Double-slider)
Y axis: SASR (Reversed)

Model Details Series Type Encoder type Axis 1 (X axis) Axis 2 (Y axis) Controllers Cable Shipping configuration

IK2 **PXBC1** **D** **P1**

Combination directions 1-2

Differences between Single-slider and Double-slider Types
HH: X high-speed, Y high-speed
HM: X high-speed, Y medium-speed

Encoder type I: Incremental

Stroke (mm)
5: 50mm
? (Can be set in 50-mm increments)

Options
NM: Opposite-home specification
SR: Slider roller specification

Cable length
1L: 1m
3L: 3m
5L: 5m
□L: □m

Wiring 1 N: Cable only
Wiring 2 CT: With cable track

Shipping configuration K: Individual components (kit)

* Refer to P.10 for details on the items comprising the model name.

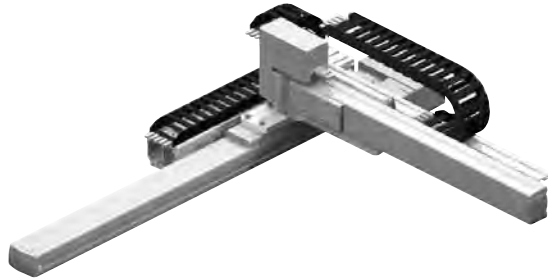

Maximum Stroke

X axis 450 mm

Y axis 400 mm

Maximum Speed (High-speed type)

X axis 400 mm/s

Y axis 600 mm/s

Maximum Load Capacity

Y-axis stroke	X high-speed, Y high-speed	X high-speed, Y medium-speed
250mm	3.0kg	6.0kg
300mm	3.0kg	6.0kg
350mm	3.0kg	6.0kg
400mm	3.0kg	6.0kg

Both wiring 1 and wiring 2 assume use of a cable track.

List by Stroke

		Incremental			
Y-axis stroke		250	300	350	400
X-axis stroke	50	-	-	-	-
	100	-	-	-	-
	150	-	-	-	-
	200	-	-	-	-
	250	-	-	-	-
	300	-	-	-	-
	350	-	-	-	-
	400	-	-	-	-
	450	-	-	-	-

Cable track

Wiring 1 (Next to X-axis)	X-axis stroke	50-300	350-450
			-
Wiring 2 (Next to Y-axis)	Y-axis stroke	250-400	-
			-

List by Cable Length

Type	Cable code	Length
Standard type	1L	1m
	3L	3m
	5L	5m

* Axis 1 comes with a standard cable, while axis 2 comes with a robot cable.

* Refer to P. 90 for lengths other than those specified above.

List of Options

Name	Option code	
Opposite-home specification	NM	
Slider roller specification	SR	Axis 1 (X-axis) Axis 2 (Y-axis)

Specifications

Item	X axis	Y axis
Axis model	RCP2-SS7R	RCP2-SA6R
Stroke (Can be set in 50-mm increments)	50-450mm	250-400mm
Max speed	HH type: 400mm/s HM type: 250mm/s	High-speed type: 600mm/s Medium-speed type: 300mm/s
Motor size	42-square pulse motor	
Ball screw lead	High-speed type: 12mm	High-speed type: 12mm Medium-speed type: 6mm
Drive method	Ball screw, ø10 mm, rolled, C10	
Positioning repeatability	±0.02mm	
Base material	Dedicated alloy steel	Aluminum
Surrounding air temperature/humidity	0 to 40°C, 85% RH or below (non-condensing)	

Dimensions

You can download CAD drawings from our website.

www.intelligentactuator.com

2D CAD

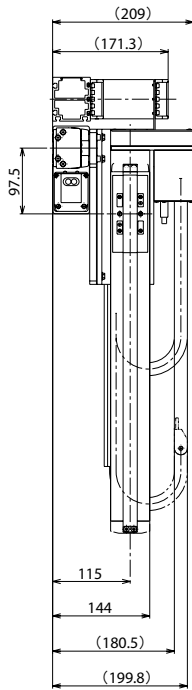

* Caution

Customer to prepare the parts and attach the X-axis cable track guide rail to the same plane the X-axis actuator is installed. Also customer to prepare the parts and attach the Y-axis cable track free end (Y-axis slider side) to the customer's bracket on the Y-axis slider.

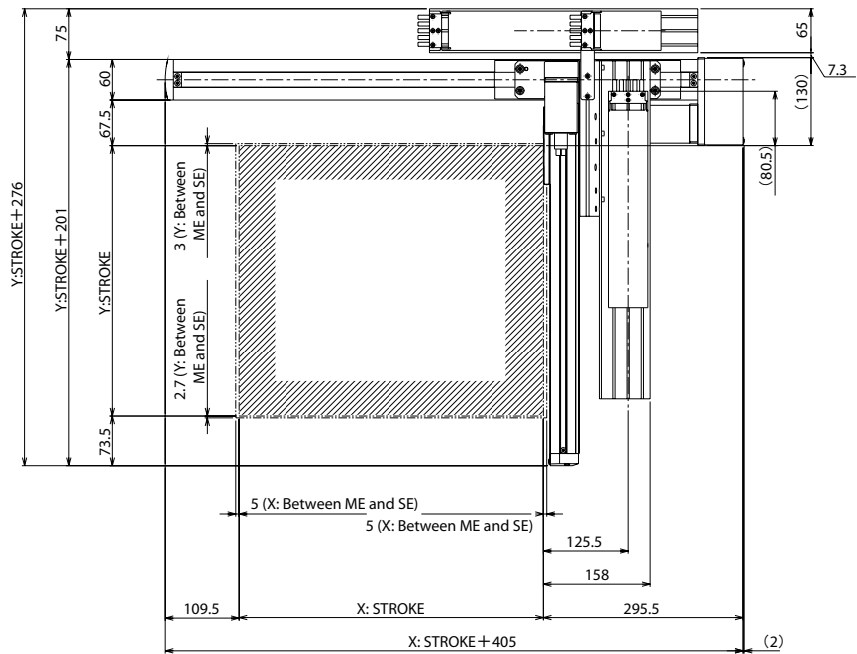

ME: Mechanical end
SE: Stroke end

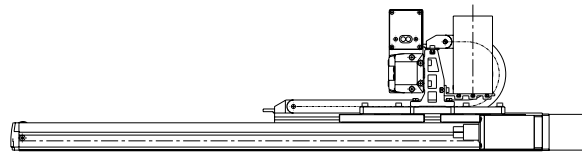

31
(Tolerance for reamed hole pitch: ±0.02)

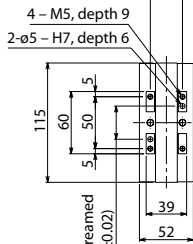

Detail view of Y-axis slider



Detail view of slot in bottom face of X-axis base

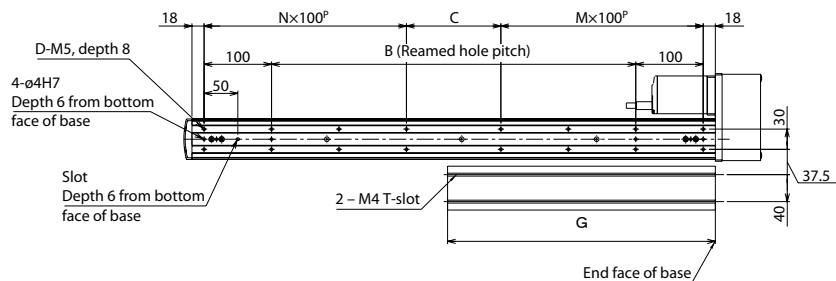

Detail view of X-axis installation

■ Dimensions by Stroke

X: Nominal stroke	200	250	300	350	400	450	500	550	600
X: Effective stroke	50	100	150	200	250	300	350	400	450
B	140	190	240	290	340	390	440	490	540
C	140	190	40	90	140	190	40	90	140
D	8	8	12	12	12	12	16	16	16
M	1	1	2	2	2	2	3	3	3
N	1	1	2	2	2	2	3	3	3
G	197	222	247	272	297	322	347	372	397

Controllers

Applicable controller



Refer to P. 91 for the controllers.

IK2-PXBC2□□S

RCP2 2-axis Combinations X axis: SS7C (Straight, Single-slider)

Y axis: SA6R (Reversed)

Model Details Series Type Encoder type Axis 1 (X axis) Axis 2 (Y axis) Controllers Cable Shipping configuration

IK2 **PXBC2** **S** **P1**

Combination directions 1-4

Differences between Single-slider and Double-slider Types
 HH: X high-speed, Y high-speed
 HM: X high-speed, Y medium-speed

Encoder type
 I: Incremental

Stroke (mm)
 5: 50mm
 ? (Can be set in 50-mm increments)

Options
 NM: Opposite-home specification
 SR: Slider roller specification

Cable length
 1L: 1m
 3L: 3m
 5L: 5m
 L: □m

Wiring 1
 N: Cable only

Wiring 2
 CT: With cable track

Shipping configuration
 K: Individual components (kit)

* Refer to P.10 for details on the items comprising the model name.

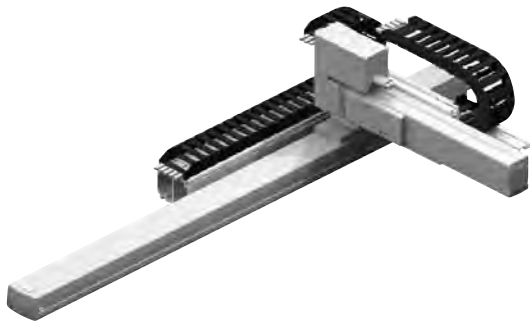

Maximum Stroke

X axis 600 mm

Y axis 200 mm

Maximum Speed (High-speed type)

X axis 400 mm/s

Y axis 600 mm/s

Maximum Load Capacity

Y-axis stroke	X high-speed, Y high-speed	X high-speed, Y medium-speed
50mm	4.5kg	9.0kg
100mm	4.5kg	9.0kg
150mm	4.0kg	8.0kg
200mm	3.0kg	6.0kg

Both wiring 1 and wiring 2 assume use of a cable track.

List by Stroke

		Incremental			
Y-axis stroke		50	100	150	200
X-axis stroke	50	-	-	-	-
	100	-	-	-	-
	150	-	-	-	-
	200	-	-	-	-
	250	-	-	-	-
	300	-	-	-	-
	350	-	-	-	-
	400	-	-	-	-
	450	-	-	-	-
	500	-	-	-	-
550	-	-	-	-	
600	-	-	-	-	

Cable track

Wiring 1 (Next to X-axis)	X-axis stroke	50-300	350-600
			-
Wiring 2 (Next to Y-axis)	Y-axis stroke	50-200	-
			-

List by Cable Length

Type	Cable code	Length
Standard type	1L	1m
	3L	3m
	5L	5m

* Axis 1 comes with a standard cable, while axis 2 comes with a robot cable.

* Refer to P.90 for lengths other than those specified above.

List of Options

Name	Option code	
Opposite-home specification	NM	
Slider roller specification	SR	Axis 1 (X-axis) Axis 2 (Y-axis)

Specifications

Item	X axis	Y axis
Axis model	RCP2-SS7C	RCP2-SA6R
Stroke (Can be set in 50-mm increments)	50-600mm	50-200mm
Max speed	HH type: 400mm/s HM type: 250mm/s	High-speed type: 600mm/s Medium-speed type: 300mm/s
Motor size	42-square pulse motor	
Ball screw lead	High-speed type: 12mm	High-speed type: 12mm Medium-speed type: 6mm
Drive method	Ball screw, ø10 mm, rolled, C10	
Positioning repeatability	±0.02mm	
Base material	Dedicated alloy steel	Aluminum
Surrounding air temperature/humidity	0 to 40°C, 85% RH or below (non-condensing)	

Dimensions

You can download CAD drawings from our website.

www.intelligentactuator.com

2D CAD

Note 1. The connected position shown in the drawing defines the home.
 Note 2. Both wiring 1 and wiring 2 assume use of a cable track.
 Note 3. For details on the cable track, refer to P.90.
 Note 4. For details on the bracket on the moving end of the cable track, refer to P.90.

* Caution

Customer to prepare the parts and attach the X-axis cable track guide rail to the same plane the X-axis actuator is installed. Also customer to prepare the parts and attach the Y-axis cable track free end (Y-axis slider side) to the customer's bracket on the Y-axis slider.

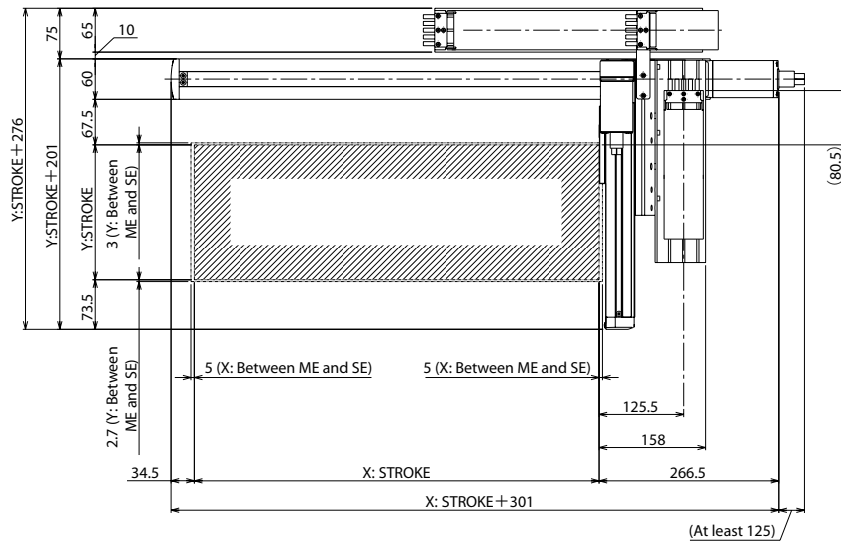
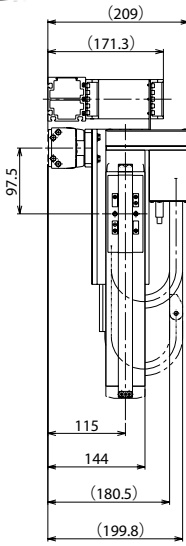

31
(Tolerance for reamed hole pitch: ±0.02)

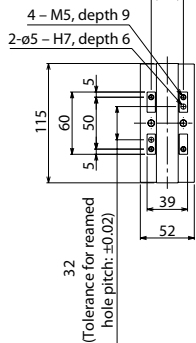

ME: Mechanical end
 SE: Stroke end

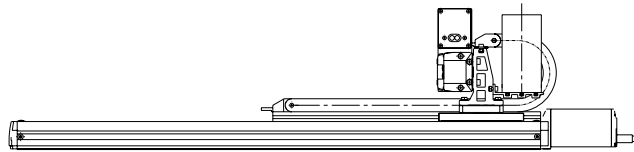

Detail view of Y-axis slider



Detail view of slot in bottom face of X-axis base

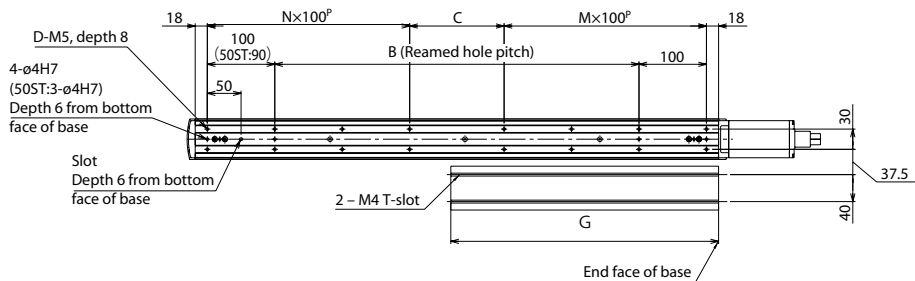

Detail view of X-axis installation

■ Dimensions by Stroke

X: Model	50	100	150	200	250	300	350	400	450	500	550	600
B	0	40	90	140	190	240	290	340	390	440	490	540
C	90	40	90	140	190	40	90	140	190	40	90	140
D	6	8	8	8	8	12	12	12	12	16	16	16
M	1	1	1	1	1	2	2	2	2	3	3	3
N	0	1	1	1	1	2	2	2	2	3	3	3
G	122	147	172	197	222	247	272	297	322	347	372	397

Controllers

Applicable controller



Refer to P. 91 for the controllers.

IK2-PXBC2□□D

RCP2 2-axis Combinations X axis: SS7C (Straight, Double-slider)
Y axis: SA6R (Reversed)

Model Details

Series: **IK2** Type: **PXBC2□□D** Encoder type: **□** Axis 1 (X axis): **□** Axis 2 (Y axis): **□** Controllers: **P1** Cable: **□** Shipping configuration: **□**

Combination directions 1-4

Differences between Single-slider and Double-slider Types
HH: X high-speed, Y high-speed
HM: X high-speed, Y medium-speed

Encoder type
I: Incremental

Stroke (mm)
5: 50mm
(Can be set in 50-mm increments)

Options
NM: Opposite-home specification
SR: Slider roller specification

Cable length
1L: 1m
3L: 3m
5L: 5m
□L: □m

Wiring 1
N: Cable only

Wiring 2
CT: With cable track

Shipping configuration
K: Individual components (kit)

* Refer to P.10 for details on the items comprising the model name.

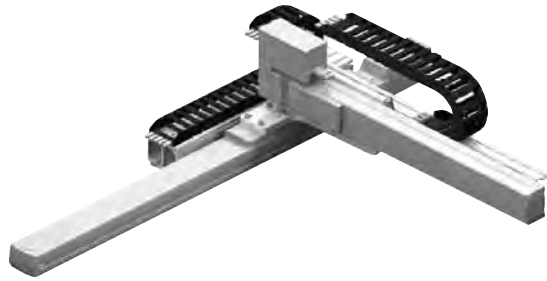

Maximum Stroke

X axis 450 mm

Y axis 400 mm

Maximum Speed (High-speed type)

X axis 400 mm/s

Y axis 600 mm/s

Maximum Load Capacity

Y-axis stroke	X high-speed, Y high-speed	X high-speed, Y medium-speed
250mm	3.0kg	6.0kg
300mm	3.0kg	6.0kg
350mm	3.0kg	6.0kg
400mm	3.0kg	6.0kg

Both wiring 1 and wiring 2 assume use of a cable track.

List by Stroke

		Incremental			
Y-axis stroke		250	300	350	400
X-axis stroke	50	-	-	-	-
	100	-	-	-	-
	150	-	-	-	-
	200	-	-	-	-
	250	-	-	-	-
	300	-	-	-	-
	350	-	-	-	-
	400	-	-	-	-
	450	-	-	-	-

Cable track

Wiring 1 (Next to X-axis)	X-axis stroke	50-300	350-450
			-
Wiring 2 (Next to Y-axis)	Y-axis stroke	250-400	-
			-

List by Cable Length

Type	Cable code	Length
Standard type	1L	1m
	3L	3m
	5L	5m

* Axis 1 comes with a standard cable, while axis 2 comes with a robot cable.

* Refer to P. 90 for lengths other than those specified above.

List of Options

Name	Option code	
Opposite-home specification	NM	
Slider roller specification	SR	Axis 1 (X-axis) Axis 2 (Y-axis)

Specifications

Item	X axis	Y axis
Axis model	RCP2-SS7C	RCP2-SA6R
Stroke (Can be set in 50-mm increments)	50-450mm	250-400mm
Max speed	HH type: 400mm/s HM type: 250mm/s	High-speed type: 600mm/s Medium-speed type: 300mm/s
Motor size	42-square pulse motor	
Ball screw lead	High-speed type: 12mm	High-speed type: 12mm Medium-speed type: 6mm
Drive method	Ball screw, ø10 mm, rolled, C10	
Positioning repeatability	±0.02mm	
Base material	Dedicated alloy steel	Aluminum
Surrounding air temperature/humidity	0 to 40°C, 85% RH or below (non-condensing)	

Dimensions

You can download CAD drawings from our website.

www.intelligentactuator.com

2D CAD

- Note 1. The connected position shown in the drawing defines the home.
- Note 2. Both wiring 1 and wiring 2 assume use of a cable track.
- Note 3. For details on the cable track, refer to P.90.
- Note 4. For details on the bracket on the moving end of the cable track, refer to P.90.

* Caution

Customer to prepare the parts and attach the X-axis cable track guide rail to the same plane the X-axis actuator is installed. Also customer to prepare the parts and attach the Y-axis cable track free end (Y-axis slider side) to the customer's bracket on the Y-axis slider.

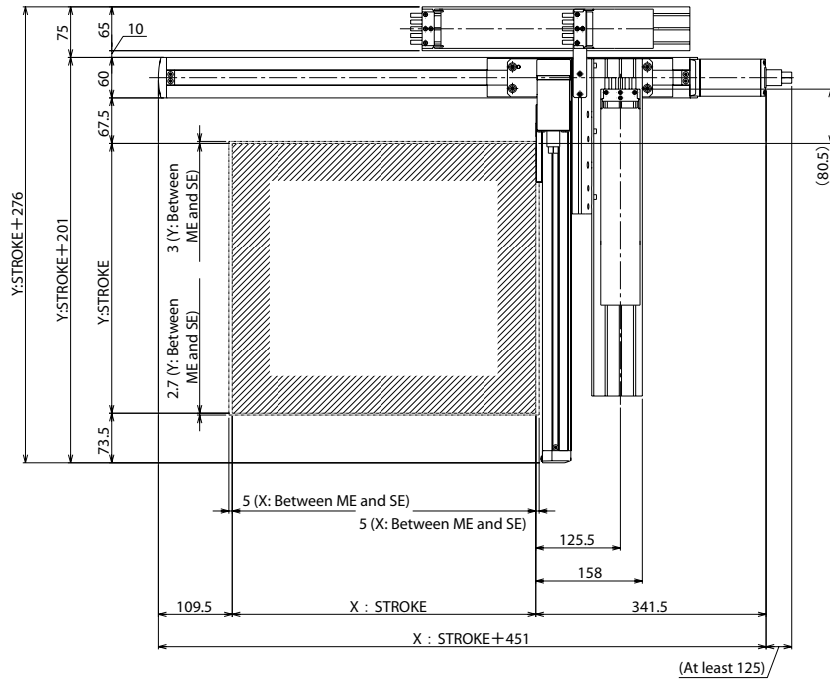
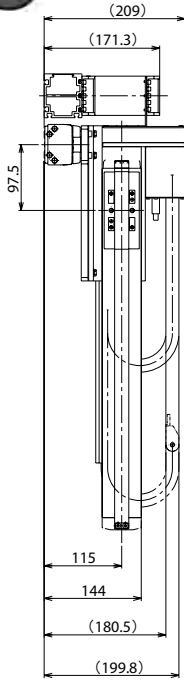

ME: Mechanical end
SE: Stroke end

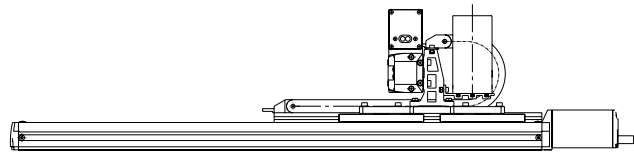

31
(Tolerance for reamed hole pitch: ±0.02)

4 - M5, depth 9
2 - Ø5 - H7, depth 6

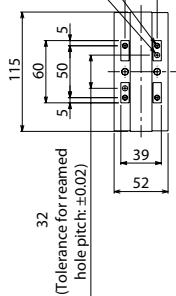

Detail view of Y-axis slider



Detail view of slot in bottom face of X-axis base

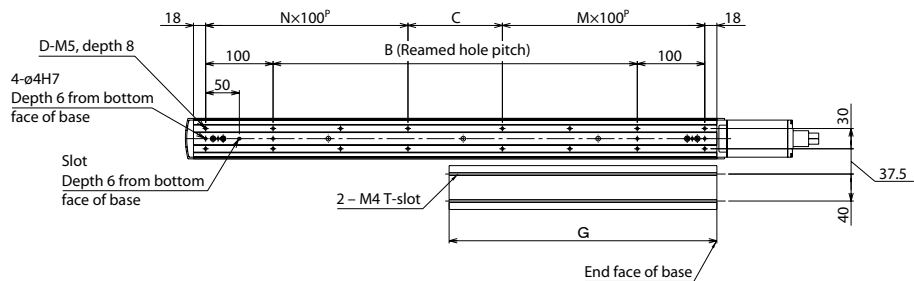

Detail view of X-axis installation

■ Dimensions by Stroke

X: Nominal stroke	200	250	300	350	400	450	500	550	600
X: Effective stroke	50	100	150	200	250	300	350	400	450
B	140	190	240	290	340	390	440	490	540
C	140	190	40	90	140	190	40	90	140
D	8	8	12	12	12	12	16	16	16
M	1	1	2	2	2	2	3	3	3
N	1	1	2	2	2	2	3	3	3
G	197	222	247	272	297	322	347	372	397

Controllers

Applicable controller



Refer to P. 91 for the controllers.

IK2-PXBB1□□S

RCP2 2-axis Combinations X axis: SS8R (Reversed, Single-slider)
Y axis: SA7R (Reversed)

Model Details

Series: **IK2** — Type: **PXBB1□□S** — Encoder type: **I** — Axis 1 (X axis): **□** — Axis 2 (Y axis): **□** — Controllers: **P1** — Cable: **□** — Shipping configuration: **□**

Combination directions 1-2: HH: X high-speed, Y high-speed; MM: X medium-speed, Y medium-speed

Differences between Single-slider and Double-slider Types

Encoder type I: Incremental

Stroke (mm): 5: 50mm; (Can be set in 50-mm increments)

Options: NM: Opposite-home specification; SR: Slider roller specification

Cable length: 1L: 1m; 3L: 3m; 5L: 5m; □L: □m

Wiring 1: N: Cable only; CT: With cable track

Wiring 2: N: Cable only; CT: With cable track

Shipping configuration K: Individual components (kit)

* Refer to P.10 for details on the items comprising the model name.

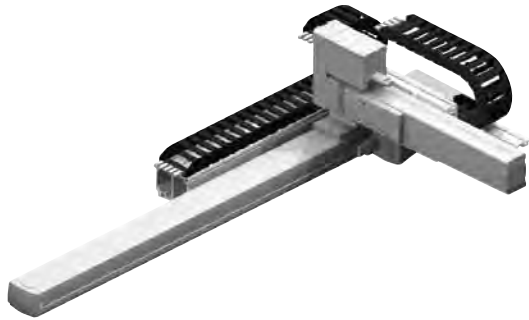

Maximum Stroke

X axis 1000 mm

Y axis 300 mm

Maximum Speed (High-speed type)

X axis 250 mm/s

Y axis 450 mm/s

Maximum Load Capacity

Y-axis stroke	X high-speed, Y high-speed	X medium-speed, Y medium-speed
50mm	8.0kg	16kg
100mm	8.0kg	16kg
150mm	7.0kg	15kg
200mm	7.0kg	12.5kg
250mm	6.0kg	9.0kg
300mm	6.0kg	8.0kg

Both wiring 1 and wiring 2 assume use of a cable track.

List by Stroke

		Incremental					
Y-axis stroke		50	100	150	200	250	300
X-axis stroke	50	-	-	-	-	-	-
	100	-	-	-	-	-	-
	150	-	-	-	-	-	-
	200	-	-	-	-	-	-
	250	-	-	-	-	-	-
	300	-	-	-	-	-	-
	350	-	-	-	-	-	-
	400	-	-	-	-	-	-
	450	-	-	-	-	-	-
	500	-	-	-	-	-	-
	550	-	-	-	-	-	-
	600	-	-	-	-	-	-
	650	-	-	-	-	-	-
	700	-	-	-	-	-	-
	750	-	-	-	-	-	-
	800	-	-	-	-	-	-
850	-	-	-	-	-	-	
900	-	-	-	-	-	-	
950	-	-	-	-	-	-	
1000	-	-	-	-	-	-	

Cable track

Wiring 1 (Next to X-axis)	X-axis stroke	50-300	350-600	650-900	950-1000
Wiring 2 (Next to Y-axis)	Y-axis stroke	50-200	250-300	-	-

List by Cable Length

Type	Cable code	Length
Standard type	1L	1m
	3L	3m
	5L	5m

* Axis 1 comes with a standard cable, while axis 2 comes with a robot cable.

* Refer to P. 90 for lengths other than those specified above.

List of Options

Name	Option code	
Opposite-home specification	NM	
Slider roller specification	SR	Axis 1 (X-axis) Axis 2 (Y-axis)

Specifications

Item	X axis	Y axis
Axis model	RCP2-SS8R	RCP2-SA7R
Stroke (Can be set in 50-mm increments)	50-1000mm	50-300mm
Max speed	High-speed type: 250mm/s Medium-speed type: 125mm/s	High-speed type: 450mm/s Medium-speed type: 220mm/s
Motor size	56-square pulse motor	
Ball screw lead	High-speed type: 20mm Medium-speed type: 10mm	High-speed type: 16mm Medium-speed type: 8mm
Drive method	Ball screw, ø16mm, rolled, C10	Ball screw, ø12mm, rolled, C10
Positioning repeatability	±0.02mm	
Base material	Dedicated alloy steel	Aluminum
Surrounding air temperature/humidity	0 to 40°C, 85% RH or below (non-condensing)	

Dimensions

You can download CAD drawings from our website.

www.intelligentactuator.com

2D CAD

- Note 1. The connected position shown in the drawing defines the home.
- Note 2. Both wiring 1 and wiring 2 assume use of a cable track.
- Note 3. For details on the cable track, refer to P. 90.
- Note 4. For details on the bracket on the moving end of the cable track, refer to P. 90.

* Caution

Customer to prepare the parts and attach the X-axis cable track guide rail to the same plane the X-axis actuator is installed. Also customer to prepare the parts and attach the Y-axis cable track free end (Y-axis slider side) to the customer's bracket on the Y-axis slider.

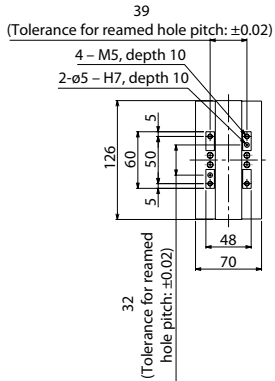
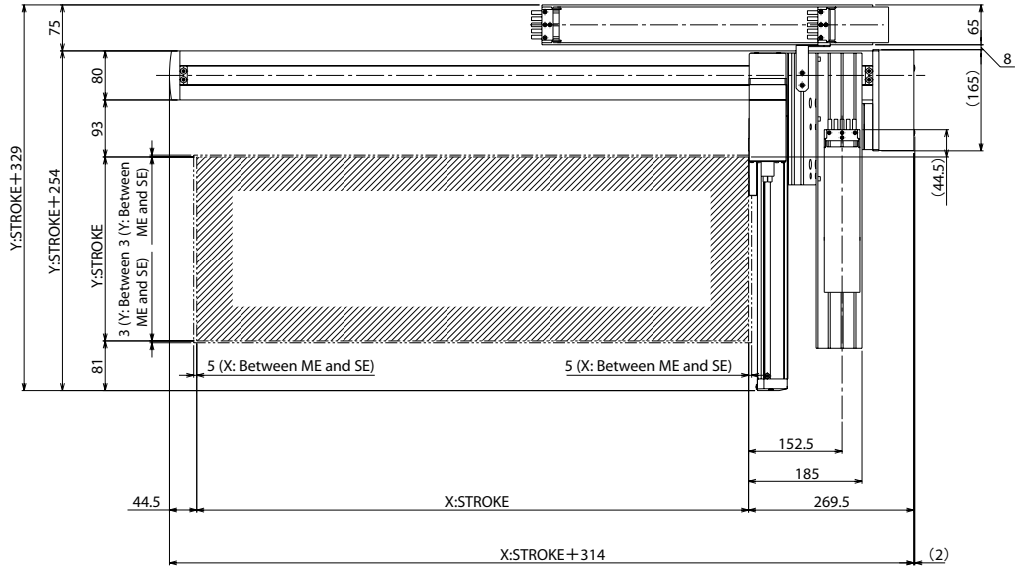
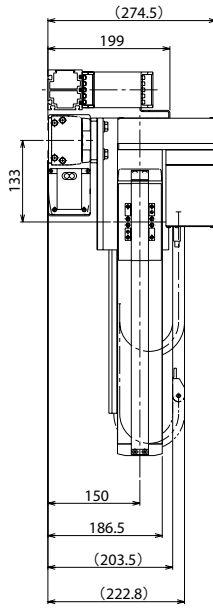

ME: Mechanical end
SE: Stroke end

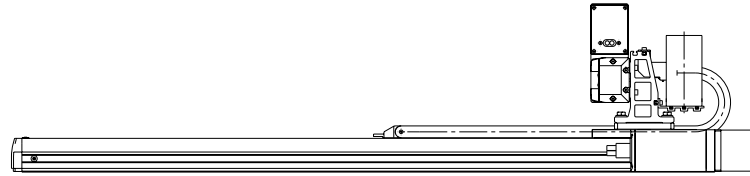

Detail view of Y-axis slider

Detail view of slot in bottom face of X-axis base



D-M8, depth 10
4-ø 5H7
Depth 6 from bottom face of base
Slot
Depth 6 from bottom face of base

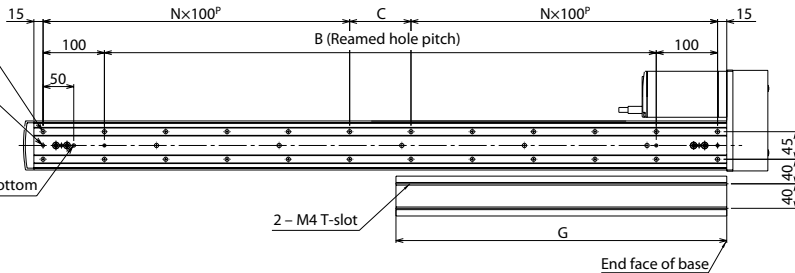

Detail view of X-axis installation

Dimensions by Stroke

X: Model	50	100	150	200	250	300	350	400	450	500	550	600	650	700	750	800	850	900	950	1000
B	50	100	150	200	250	300	350	400	450	500	550	600	650	700	750	800	850	900	950	1000
C	50	100	150	0	50	100	150	0	50	100	150	0	50	100	150	0	50	100	150	0
D	8	8	8	10	12	12	12	14	16	16	16	18	20	20	20	22	24	24	24	26
N	1	1	1	2	2	2	2	3	3	3	3	4	4	4	4	5	5	5	5	6
G	114.5	139.5	164.5	189.5	214.5	239.5	264.5	289.5	314.5	339.5	364.5	389.5	414.5	439.5	464.5	489.5	514.5	539.5	564.5	589.5

Controllers

Applicable controller



Refer to P. 91 for the controllers.

IK2-PXBB1□□D

RCP2 2-axis Combinations X axis: SS8R (Reversed, Double-slider)
Y axis: SA7R (Reversed)

Model Details

Series: IK2 Type: PXBB1□□D Encoder type: □ Axis 1 (X axis): □ Axis 2 (Y axis): □ Controllers: P1 Cable: □ Shipping configuration: □

Combination directions 1-2
Differences between Single-slider and Double-slider Types
HH: X high-speed, Y high-speed
MM: X medium-speed, Y medium-speed

Encoder type
I: Incremental

Stroke (mm)
5: 50mm
(Can be set in 50-mm increments)

Options
NM: Opposite-home specification
SR: Slider roller specification

Cable length
1L: 1m
3L: 3m
5L: 5m
□L: □m

Wiring 1
N: Cable only
CT: With cable track

Wiring 2

Shipping configuration
K: Individual components (kit)

* Refer to P.10 for details on the items comprising the model name.

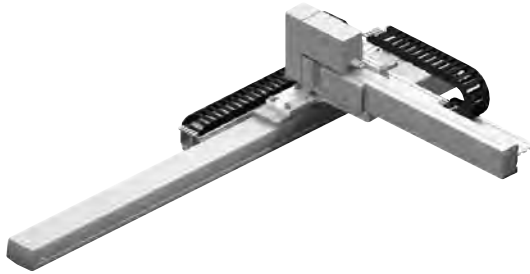

Maximum Stroke

X axis 800 mm

Y axis 400 mm

Maximum Speed (High-speed type)

X axis 250 mm/s

Y axis 450 mm/s

Maximum Load Capacity

Y-axis stroke	X high-speed, Y high-speed	X medium-speed, Y medium-speed
200mm	–	15kg
250mm	–	12.5kg
300mm	–	12.5kg
350mm	6.0kg	12kg
400mm	5.5kg	10.5kg

Both wiring 1 and wiring 2 assume use of a cable track.

List by Stroke

		Incremental				
Y-axis stroke		200	250	300	350	400
X-axis stroke	50	–	–	–	–	–
	100	–	–	–	–	–
	150	–	–	–	–	–
	200	–	–	–	–	–
	250	–	–	–	–	–
	300	–	–	–	–	–
	350	–	–	–	–	–
	400	–	–	–	–	–
	450	–	–	–	–	–
	500	–	–	–	–	–
	550	–	–	–	–	–
	600	–	–	–	–	–
	650	–	–	–	–	–
	700	–	–	–	–	–
	750	–	–	–	–	–
	800	–	–	–	–	–

Note: For the X high-speed/Y high-speed type, the Y-axis stroke must be 350 mm or more.

Cable track

Wiring 1 (Next to X-axis)	X-axis stroke	50-300	350-600	650-800
Wiring 2 (Next to Y-axis)	Y-axis stroke	200	250-400	–
				–

List by Cable Length

Type	Cable code	Length
Standard type	1L	1m
	3L	3m
	5L	5m

* Axis 1 comes with a standard cable, while axis 2 comes with a robot cable.
* Refer to P.90 for lengths other than those specified above.

List of Options

Name	Option code	
Opposite-home specification	NM	
Slider roller specification	SR	Axis 1 (X-axis) Axis 2 (Y-axis)

Specifications

Item	X axis	Y axis
Axis model	RCP2-SS8R	RCP2-SA7R
Stroke (Can be set in 50-mm increments)	50-800mm	High-speed type: 350-400mm Medium-speed type: 200-400mm
Max speed	High-speed type: 250mm/s Medium-speed type: 125mm/s	High-speed type: 450mm/s Medium-speed type: 220mm/s
Motor size	56-square pulse motor	
Ball screw lead	High-speed type: 20mm Medium-speed type: 10mm	High-speed type: 16mm Medium-speed type: 8mm
Drive method	Ball screw, ø16mm, rolled, C10	Ball screw, ø12mm, rolled, C10
Positioning repeatability	±0.02mm	
Base material	Dedicated alloy steel	Aluminum
Surrounding air temperature/humidity	0 to 40°C, 85% RH or below (non-condensing)	

Dimensions

You can download CAD drawings from our website.

www.intelligentactuator.com

2D CAD

- Note 1. The connected position shown in the drawing defines the home.
- Note 2. Both wiring 1 and wiring 2 assume use of a cable track.
- Note 3. For details on the cable track, refer to P.90.
- Note 4. For details on the bracket on the moving end of the cable track, refer to P.90.

* Caution

Customer to prepare the parts and attach the X-axis cable track guide rail to the same plane the X-axis actuator is installed. Also customer to prepare the parts and attach the Y-axis cable track free end (Y-axis slider side) to the customer's bracket on the Y-axis slider.

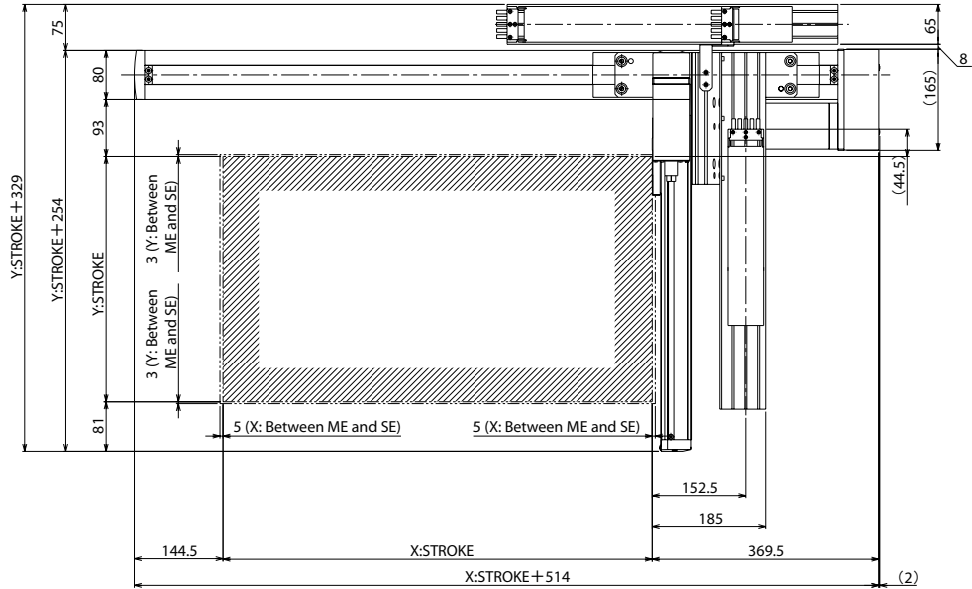
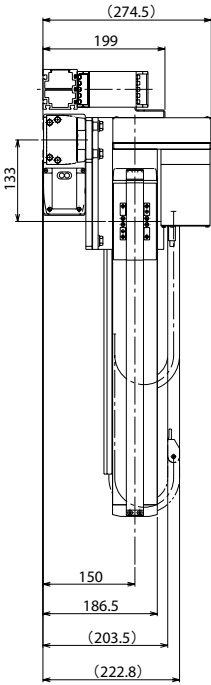

ME: Mechanical end
SE: Stroke end

(Tolerance for reamed hole pitch: ±0.02)

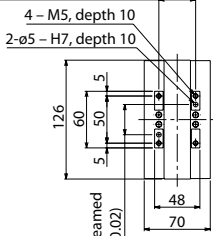

Detail view of Y-axis slider

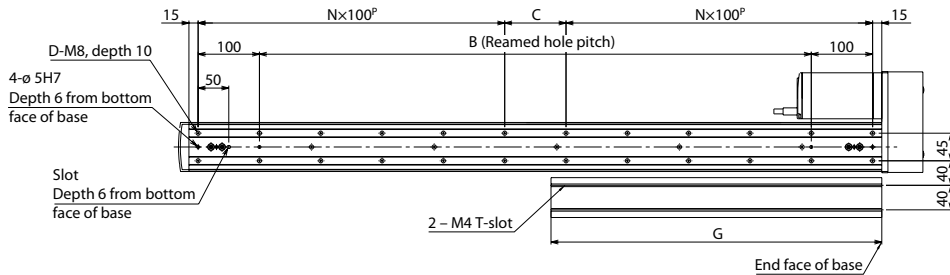
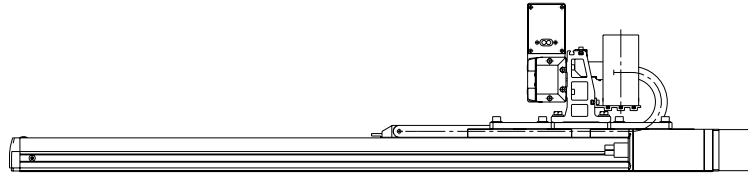

Detail view of X-axis installation

Detail view of slot in bottom face of X-axis base

■ Dimensions by Stroke

X: Nominal stroke	250	300	350	400	450	500	550	600	650	700	750	800	850	900	950	1000
X: Effective stroke	50	100	150	200	250	300	350	400	450	500	550	600	650	700	750	800
B	250	300	350	400	450	500	550	600	650	700	750	800	850	900	950	1000
C	50	100	150	0	50	100	150	0	50	100	150	0	50	100	150	0
D	12	12	12	14	16	16	16	18	20	20	20	22	24	24	24	26
N	2	2	2	3	3	3	3	4	4	4	4	5	5	5	5	6
G	214.5	239.5	264.5	289.5	314.5	339.5	364.5	389.5	414.5	439.5	464.5	489.5	514.5	539.5	564.5	589.5

Controllers

Applicable controller



Refer to P. 91 for the controllers.

IK2-PXBB2□□S

RCP2 2-axis Combinations X axis: SS8C (Straight, Single-slider)
Y axis: SA7R (Reversed)

Model Details

Series: IK2 Type: PXBB2□□S Encoder type: I: Incremental Axis 1 (X axis): □ Axis 2 (Y axis): □ Controllers: P1 Cable: □ Shipping configuration: □

Combination directions 1-4

Differences between Single-slider and Double-slider Types
 HH: X high-speed, Y high-speed
 MM: X medium-speed, Y medium-speed

Encoder type
I: Incremental

Stroke (mm)
5: 50mm
(Can be set in 50-mm increments)

Options
 NM: Opposite-home specification
 SR: Slider roller specification

Cable length
 1L: 1m
 3L: 3m
 5L: 5m
 □L: □m

Wiring 1
N: Cable only
CT: With cable track

Wiring 2
□

Shipping configuration
K: Individual components (kit)

* Refer to P.10 for details on the items comprising the model name.



Maximum Stroke

X axis 1000 mm Y axis 300 mm

Maximum Speed (High-speed type)

X axis 250 mm/s Y axis 450 mm/s

Maximum Load Capacity

Y-axis stroke	X high-speed, Y high-speed	X medium-speed, Y medium-speed
50mm	8.0kg	16kg
100mm	8.0kg	16kg
150mm	7.0kg	15kg
200mm	7.0kg	12.5kg
250mm	6.0kg	9.0kg
300mm	6.0kg	8.0kg

Both wiring 1 and wiring 2 assume use of a cable track.

List by Stroke

		Incremental					
Y-axis stroke		50	100	150	200	250	300
X-axis stroke	50	-	-	-	-	-	-
	100	-	-	-	-	-	-
	150	-	-	-	-	-	-
	200	-	-	-	-	-	-
	250	-	-	-	-	-	-
	300	-	-	-	-	-	-
	350	-	-	-	-	-	-
	400	-	-	-	-	-	-
	450	-	-	-	-	-	-
	500	-	-	-	-	-	-
	550	-	-	-	-	-	-
	600	-	-	-	-	-	-
	650	-	-	-	-	-	-
	700	-	-	-	-	-	-
	750	-	-	-	-	-	-
	800	-	-	-	-	-	-
850	-	-	-	-	-	-	
900	-	-	-	-	-	-	
950	-	-	-	-	-	-	
1000	-	-	-	-	-	-	

Cable track

Wiring 1 (Next to X-axis)	X-axis stroke	50-300	350-600	650-900	950-1000
	Y-axis stroke	50-200	250-300	-	-
Wiring 2 (Next to Y-axis)					

List by Cable Length

Type	Cable code	Length
Standard type	1L	1m
	3L	3m
	5L	5m

* Axis 1 comes with a standard cable, while axis 2 comes with a robot cable.
* Refer to P. 90 for lengths other than those specified above.

List of Options

Name	Option code	
Opposite-home specification	NM	
Slider roller specification	SR	Axis 1 (X-axis) Axis 2 (Y-axis)

Specifications

Item	X axis	Y axis
Axis model	RCP2-SS8C	RCP2-SA7R
Stroke (Can be set in 50-mm increments)	50-1000mm	50-300mm
Max speed	High-speed type: 250mm/s Medium-speed type: 125mm/s	High-speed type: 450mm/s Medium-speed type: 220mm/s
Motor size	56-square pulse motor	
Ball screw lead	High-speed type: 20mm Medium-speed type: 10mm	High-speed type: 16mm Medium-speed type: 8mm
Drive method	Ball screw, ø16mm, rolled, C10	Ball screw, ø12mm, rolled, C10
Positioning repeatability	±0.02mm	
Base material	Dedicated alloy steel	Aluminum
Surrounding air temperature/humidity	0 to 40°C, 85% RH or below (non-condensing)	

Dimensions

You can download CAD drawings from our website.

www.intelligentactuator.com

2D CAD

- Note 1. The connected position shown in the drawing defines the home.
- Note 2. Both wiring 1 and wiring 2 assume use of a cable track.
- Note 3. For details on the cable track, refer to P.90.
- Note 4. For details on the bracket on the moving end of the cable track, refer to P.90.

* Caution

Customer to prepare the parts and attach the X-axis cable track guide rail to the same plane the X-axis actuator is installed. Also customer to prepare the parts and attach the Y-axis cable track free end (Y-axis slider side) to the customer's bracket on the Y-axis slider.

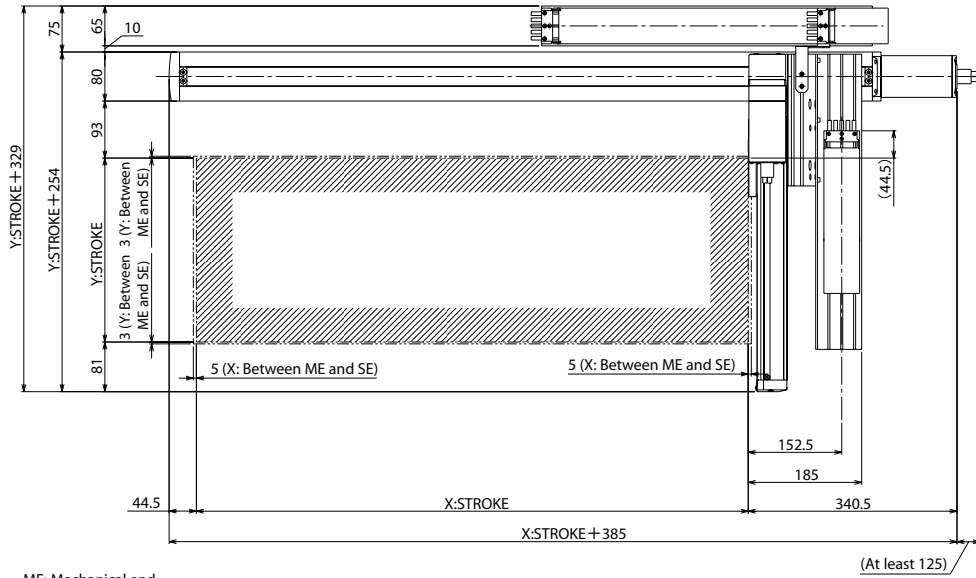
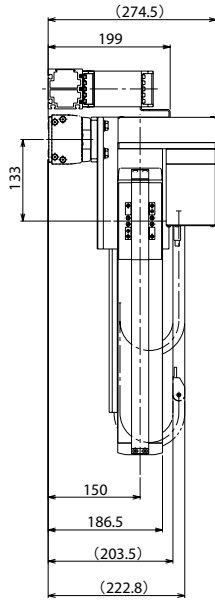

ME: Mechanical end
SE: Stroke end

39
(Tolerance for reamed hole pitch: ±0.02)

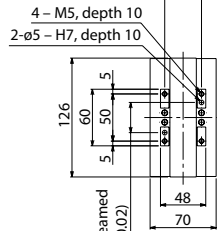

32
(Tolerance for reamed hole pitch: ±0.02)

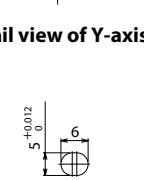

Detail view of Y-axis slider

D-M8, depth 10
4-ø 5H7
Depth 6 from bottom face of base

Detail view of slot in bottom face of X-axis base

Slot
Depth 6 from bottom face of base

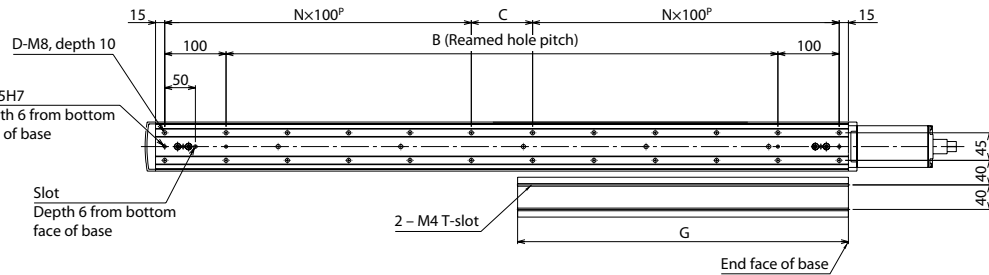
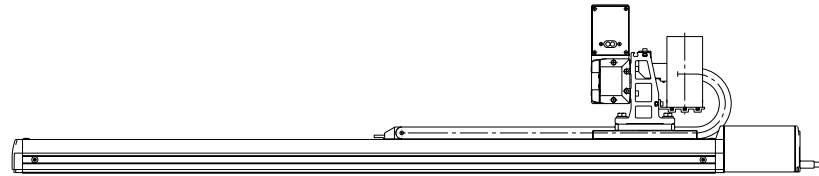

Detail view of X-axis installation

Dimensions by Stroke

X: Model	50	100	150	200	250	300	350	400	450	500	550	600	650	700	750	800	850	900	950	1000
B	50	100	150	200	250	300	350	400	450	500	550	600	650	700	750	800	850	900	950	1000
C	50	100	150	0	50	100	150	0	50	100	150	0	50	100	150	0	50	100	150	0
D	8	8	8	10	12	12	12	14	16	16	16	18	20	20	20	22	24	24	24	26
N	1	1	1	2	2	2	2	3	3	3	3	4	4	4	4	5	5	5	5	6
G	114.5	139.5	164.5	189.5	214.5	239.5	264.5	289.5	314.5	339.5	364.5	389.5	414.5	439.5	464.5	489.5	514.5	539.5	564.5	589.5

Controllers

Applicable controller



Refer to P. 91 for the controllers.

IK2-PXBB2□□D

RCP2 2-axis Combinations X axis: SS8C (Straight, Double-slider)
Y axis: SA7R (Reversed)

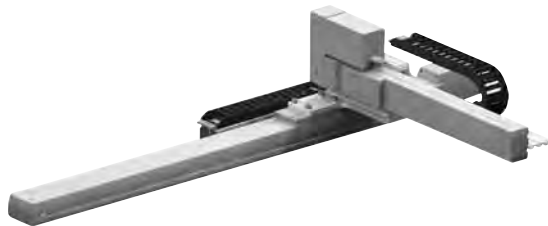
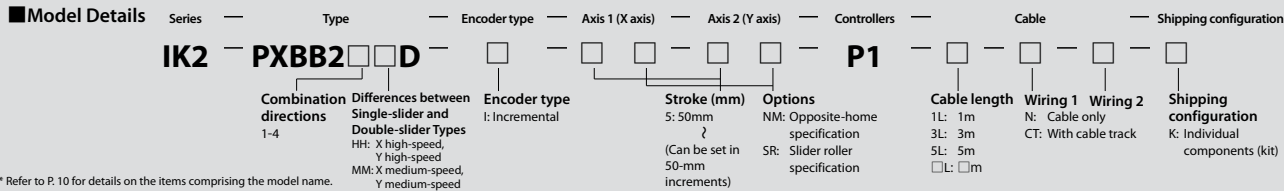

Maximum Stroke

X axis 800 mm Y axis 400 mm

Maximum Speed (High-speed type)

X axis 250 mm/s Y axis 450 mm/s

Maximum Load Capacity

Y-axis stroke	X high-speed, Y high-speed	X medium-speed, Y medium-speed
200mm	–	15kg
250mm	–	12.5kg
300mm	–	12.5kg
350mm	6.0kg	12kg
400mm	5.5kg	10.5kg

Both wiring 1 and wiring 2 assume use of a cable track.

List by Stroke

		Incremental				
Y-axis stroke		200	250	300	350	400
X-axis stroke	50	–	–	–	–	–
	100	–	–	–	–	–
	150	–	–	–	–	–
	200	–	–	–	–	–
	250	–	–	–	–	–
	300	–	–	–	–	–
	350	–	–	–	–	–
	400	–	–	–	–	–
	450	–	–	–	–	–
	500	–	–	–	–	–
	550	–	–	–	–	–
	600	–	–	–	–	–
	650	–	–	–	–	–
	700	–	–	–	–	–
	750	–	–	–	–	–
	800	–	–	–	–	–

Note: For the X high-speed/Y high-speed type, the Y-axis stroke must be 350 mm or more.

Cable track

Wiring 1 (Next to X-axis)	X-axis stroke	50-300	350-600	650-800
Wiring 2 (Next to Y-axis)	Y-axis stroke	200	250-400	–
				–

List by Cable Length

Type	Cable code	Length
Standard type	1L	1m
	3L	3m
	5L	5m

* Axis 1 comes with a standard cable, while axis 2 comes with a robot cable.
* Refer to P. 90 for lengths other than those specified above.

List of Options

Name	Option code	
Opposite-home specification	NM	
Slider roller specification	SR	Axis 1 (X-axis) Axis 2 (Y-axis)

Specifications

Item	X axis	Y axis
Axis model	RCP2-SS8C	RCP2-SA7R
Stroke (Can be set in 50-mm increments)	50-800mm	High-speed type: 350-400mm Medium-speed type: 200-400mm
Max speed	High-speed type: 250mm/s Medium-speed type: 125mm/s	High-speed type: 450mm/s Medium-speed type: 220mm/s
Motor size	56-square pulse motor	
Ball screw lead	High-speed type: 20mm Medium-speed type: 10mm	High-speed type: 16mm Medium-speed type: 8mm
Drive method	Ball screw, ø16mm, rolled, C10	Ball screw, ø12mm, rolled, C10
Positioning repeatability	±0.02mm	
Base material	Dedicated alloy steel	Aluminum
Surrounding air temperature/humidity	0 to 40°C, 85% RH or below (non-condensing)	

Dimensions

You can download CAD drawings from our website.

www.intelligentactuator.com

2D CAD

- Note 1. The connected position shown in the drawing defines the home.
- Note 2. Both wiring 1 and wiring 2 assume use of a cable track.
- Note 3. For details on the cable track, refer to P. 90.
- Note 4. For details on the bracket on the moving end of the cable track, refer to P. 90.

* Caution

Customer to prepare the parts and attach the X-axis cable track guide rail to the same plane the X-axis actuator is installed. Also customer to prepare the parts and attach the Y-axis cable track free end (Y-axis slider side) to the customer's bracket on the Y-axis slider.

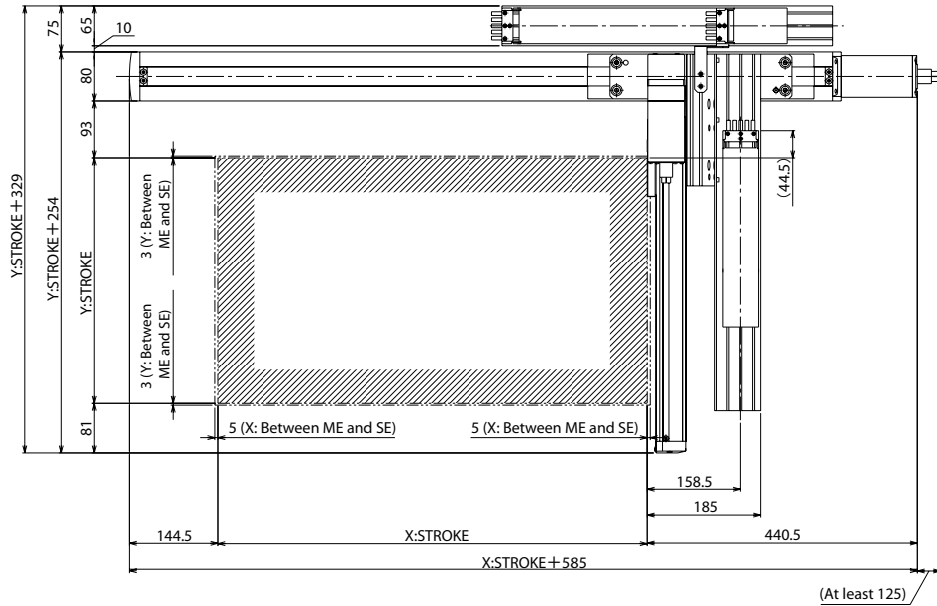
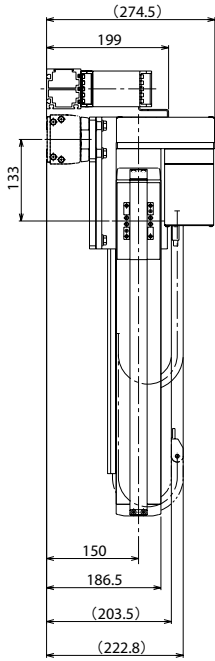

ME: Mechanical end
SE: Stroke end

39
(Tolerance for reamed hole pitch: ±0.02)

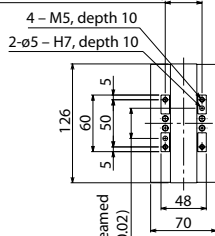

Detail view of Y-axis slider



Detail view of slot in bottom face of X-axis base

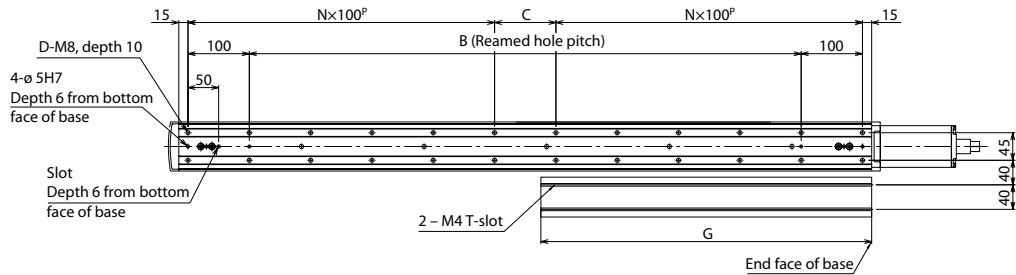
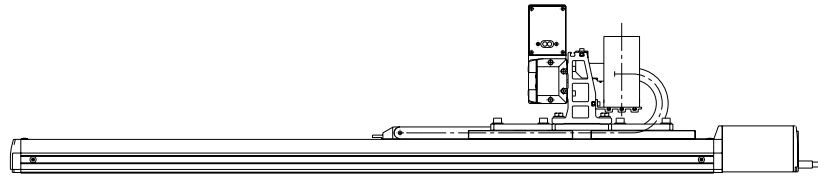

Detail view of X-axis installation

■ Dimensions by Stroke

X: Nominal stroke	250	300	350	400	450	500	550	600	650	700	750	800	850	900	950	1000
X: Effective stroke	50	100	150	200	250	300	350	400	450	500	550	600	650	700	750	800
B	250	300	350	400	450	500	550	600	650	700	750	800	850	900	950	1000
C	50	100	150	0	50	100	150	0	50	100	150	0	50	100	150	0
D	12	12	12	14	16	16	16	18	20	20	20	22	24	24	24	26
N	2	2	2	3	3	3	3	4	4	4	4	5	5	5	5	6
G	214.5	239.5	264.5	289.5	314.5	339.5	364.5	389.5	414.5	439.5	464.5	489.5	514.5	539.5	564.5	589.5

Controllers

Applicable controller



Refer to P. 91 for the controllers.

IK2-PXZB1□□S

RCP2 2-axis Combinations X axis: SS8R (Reversed, Single-slider)
Z axis: SA7R (Reversed)

Model Details

Series: **IK2** Type: **PXZB1□□S** Encoder type: **I** Axis 1 (X axis): **□** Axis 2 (Z axis): **□** Controllers: **P1** Cable: **□** Shipping configuration: **□**

Combination directions 1-4

Differences between Single-slider and Double-slider Types
 HH: X high-speed, Z high-speed
 HM: X high-speed, Z medium-speed
 HL: X high-speed, Z low-speed

Encoder type
 I: Incremental

Stroke (mm)
 5: 50mm
 ? (Can be set in 50-mm increments)

Options
 B: Brake
 NM: Opposite-home specification
 SR: Slider roller specification

Cable length
 1L: 1m
 3L: 3m
 5L: 5m
 □L: □m

Wiring 1
 N: Cable only
 CT: With cable track

Wiring 2

Shipping configuration
 K: Individual components (kit)

* Refer to P.10 for details on the items comprising the model name.



Wiring 1 with cable track

Maximum Stroke

X axis 1000 mm

Z axis 250 mm

Maximum Speed (High-speed type)

X axis 250 mm/s

Z axis 360 mm/s

Maximum Load Capacity

Z-axis stroke	Z high-speed, lead 16	Z medium-speed, lead 8	Z low-speed, lead 4
50mm	2.0kg	4.0kg	8.0kg
100mm	2.0kg	4.0kg	7.0kg
150mm	2.0kg	3.5kg	5.0kg
200mm	2.0kg	3.5kg	4.0kg
250mm	1.5kg	2.5kg	3.0kg

List by Stroke

Z-axis stroke	Incremental				
	50	100	150	200	250
50	-	-	-	-	-
100	-	-	-	-	-
150	-	-	-	-	-
200	-	-	-	-	-
250	-	-	-	-	-
300	-	-	-	-	-
350	-	-	-	-	-
400	-	-	-	-	-
450	-	-	-	-	-
500	-	-	-	-	-
550	-	-	-	-	-
600	-	-	-	-	-
650	-	-	-	-	-
700	-	-	-	-	-
750	-	-	-	-	-
800	-	-	-	-	-
850	-	-	-	-	-
900	-	-	-	-	-
950	-	-	-	-	-
1000	-	-	-	-	-

Cable track

Wiring 1 (Next to X-axis)	X-axis stroke	150-300	350-600	650-900	950-1000

List by Cable Length

Type	Cable code	Length
Standard type	1L	1m
	3L	3m
	5L	5m

* Axis 1 comes with a standard cable, while axis 2 comes with a robot cable.
 * Refer to P.90 for lengths other than those specified above.

List of Options

Name	Option code	
Opposite-home specification	NM	
Slider roller specification	SR	Axis 1 (X-axis) Axis 2 (Z-axis)

Specifications

Item	X axis	Z axis
Axis model	RCP2-SS8R	RCP2-SA7R
Stroke (Can be set in 50-mm increments)	50-1000mm	50-250mm
Max speed	High-speed type: 250mm/s	High-speed type: 360mm/s Medium-speed type: 180mm/s Low-speed type: 90mm/s
Motor size	56-square pulse motor	
Ball screw lead	High-speed type: 20mm	High-speed type: 16mm Medium-speed type: 8mm Low-speed type: 4mm
Drive method	Ball screw, ø16mm, rolled, C10	Ball screw, ø12mm, rolled, C10
Positioning repeatability	±0.02mm	
Base material	Dedicated alloy steel	Aluminum
Surrounding air temperature/humidity	0 to 40°C, 85% RH or below (non-condensing)	

Dimensions

You can download CAD drawings from our website.

www.intelligentactuator.com

2D CAD

- Note 1. The connected position shown in the drawing defines the home.
- Note 2. Both wiring 1 and wiring 2 assume use of a cable track.
- Note 3. For details on the cable track, refer to P.90.
- Note 4. For details on the bracket on the moving end of the cable track, refer to P.90.

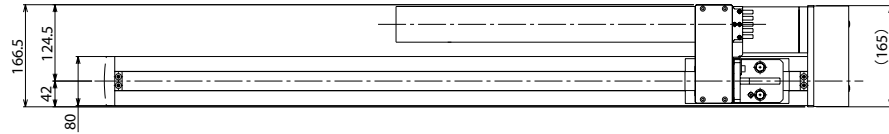

* Caution
Customer to prepare the parts and attach X-axis cable track fix end (non-slider side) to the same plane the X-axis actuator is installed. (There is no cable track guide rail.)

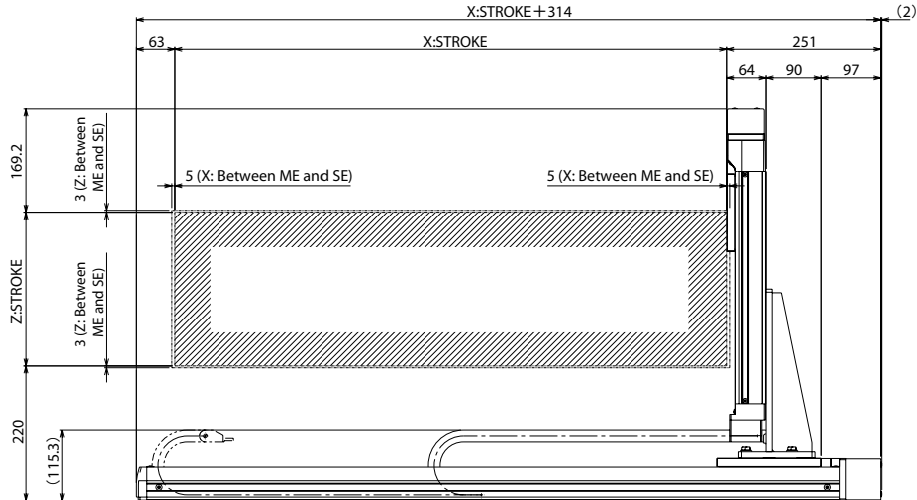
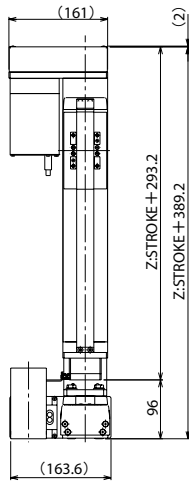

ME: Mechanical end
SE: Stroke end

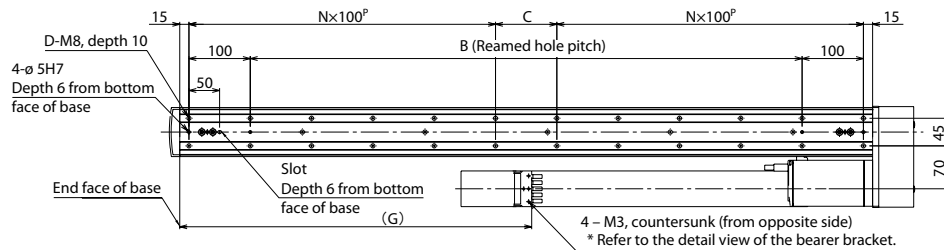
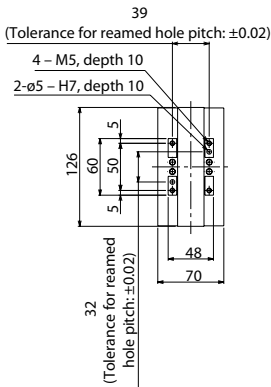

Detail view of X-axis installation

Detail view of Z-axis slider

Detail view of slot in bottom face of X-axis base

Dimensions by Stroke

X: Model	50	100	150	200	250	300	350	400	450	500	550	600	650	700	750	800	850	900	950	1000
B	50	100	150	200	250	300	350	400	450	500	550	600	650	700	750	800	850	900	950	1000
C	50	100	150	0	50	100	150	0	50	100	150	0	50	100	150	0	50	100	150	0
D	8	8	8	10	12	12	12	14	16	16	16	18	20	20	20	22	24	24	24	26
N	1	1	1	2	2	2	2	3	3	3	3	4	4	4	4	5	5	5	5	6
G	-	-	199	224	249	274	299	324	349	374	399	424	449	474	499	524	549	574	599	624

* A bearer is not set when the X stroke is 50 or 100.

Controllers

Applicable controller



Refer to P. 91 for the controllers.

IK2-PXZB1□□D

RCP2 2-axis Combinations X axis: SS8R (Reversed, Double-slider)
Z axis: SA7R (Reversed)

Model Details

Series: **IK2** Type: **PXZB1□□D** Encoder type: Axis 1 (X axis): Axis 2 (Z axis): Controllers: **P1** Cable: Shipping configuration:

Combination directions 1-4

Differences between Single-slider and Double-slider Types
HH: X high-speed, Z high-speed
HM: X high-speed, Z medium-speed
HL: X high-speed, Z low-speed

Encoder type
I: Incremental

Stroke (mm)
5: 50mm
(Can be set in 50-mm increments)

Options
B: Brake
NM: Opposite-home specification
SR: Slider roller specification

Cable length
1L: 1m
3L: 3m
5L: 5m
L: m

Wiring 1
N: Cable only

Wiring 2
CT: With cable track

Shipping configuration
K: Individual components (kit)

* Refer to P.10 for details on the items comprising the model name.



Wiring 1 with cable track

Maximum Stroke

X axis 800 mm

Z axis 300 mm

Maximum Speed (High-speed type)

X axis 250 mm/s

Z axis 400 mm/s

Maximum Load Capacity

Z-axis stroke	Z high-speed, lead 16	Z medium-speed, lead 8	Z low-speed, lead 4
150mm	–	–	7.0kg
200mm	–	–	7.0kg
250mm	–	–	5.5kg
300mm	1.5kg	3.0kg	5.5kg

List by Stroke

		Incremental			
Z-axis stroke		150	200	250	300
X-axis stroke	50	–	–	–	–
	100	–	–	–	–
	150	–	–	–	–
	200	–	–	–	–
	250	–	–	–	–
	300	–	–	–	–
	350	–	–	–	–
	400	–	–	–	–
	450	–	–	–	–
	500	–	–	–	–
	550	–	–	–	–
	600	–	–	–	–
650	–	–	–	–	
700	–	–	–	–	
750	–	–	–	–	
800	–	–	–	–	

Note: For the Z high-speed type and Z medium-speed type, The Z-axis stroke is limited to 300 mm.

Cable track

Wiring 1 (Next to X-axis)	X-axis stroke	150-300	350-600	650-800

List by Cable Length

Type	Cable code	Length
Standard type	1L	1m
	3L	3m
	5L	5m

* Axis 1 comes with a standard cable, while axis 2 comes with a robot cable.

* Refer to P.90 for lengths other than those specified above.

List of Options

Name	Option code	
Opposite-home specification	NM	
Slider roller specification	SR	Axis 1 (X-axis) Axis 2 (Z-axis)

Specifications

Item	X axis	Z axis
Axis model	RCP2-SS8R	RCP2-SA7R
Stroke (Can be set in 50-mm increments)	50-800mm	High-speed type: 300mm Medium-speed type: 300mm Low-speed type: 150-300mm
Max speed	High-speed type: 250mm/s	High-speed type: 400mm/s Medium-speed type: 200mm/s Low-speed type: 100mm/s
Motor size	56-square pulse motor	
Ball screw lead	High-speed type: 20mm	High-speed type: 16mm Medium-speed type: 8mm Low-speed type: 4mm
Drive method	Ball screw, ø16mm, rolled, C10	Ball screw, ø12mm, rolled, C10
Positioning repeatability	±0.02mm	
Base material	Dedicated alloy steel	Aluminum
Surrounding air temperature/humidity	0 to 40°C, 85% RH or below (non-condensing)	

Dimensions

You can download CAD drawings from our website.

www.intelligentactuator.com

2D CAD

- Note 1. The connected position shown in the drawing defines the home.
- Note 2. Both wiring 1 and wiring 2 assume use of a cable track.
- Note 3. For details on the cable track, refer to P.90.
- Note 4. For details on the bracket on the moving end of the cable track, refer to P.90.

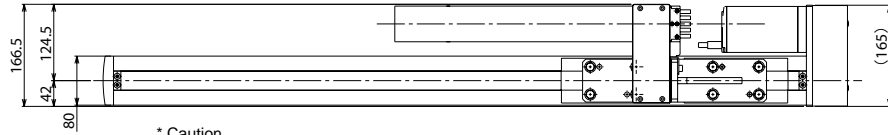

* Caution

Customer to prepare the parts and attach X-axis cable track fix end (non-slider side) to the same plane the X-axis actuator is installed. (There is no cable track guide rail.)

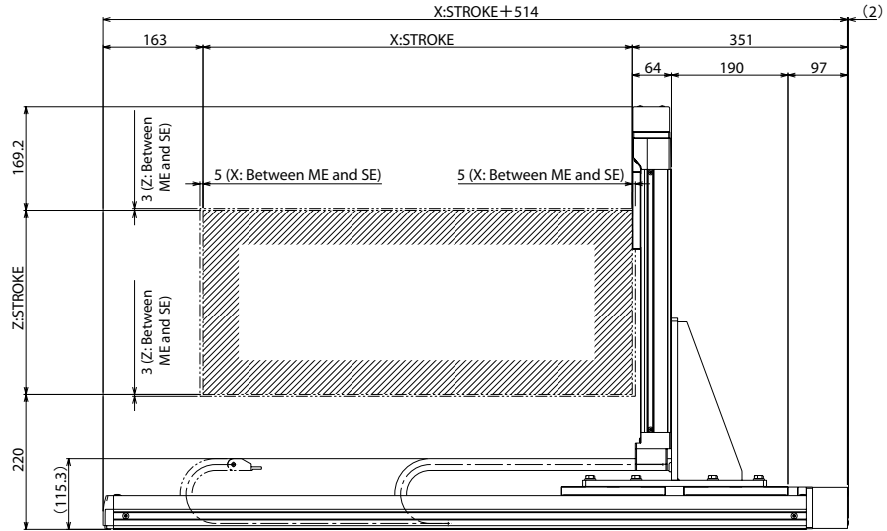
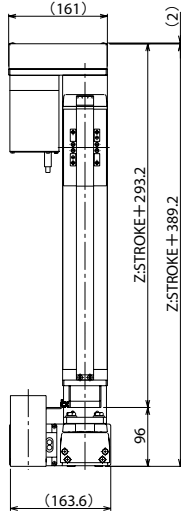

ME: Mechanical end
SE: Stroke end

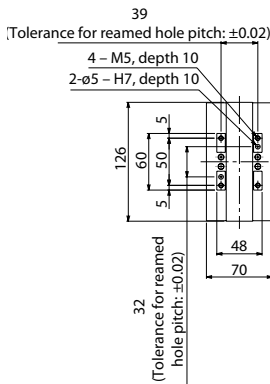

Detail view of Z-axis slider

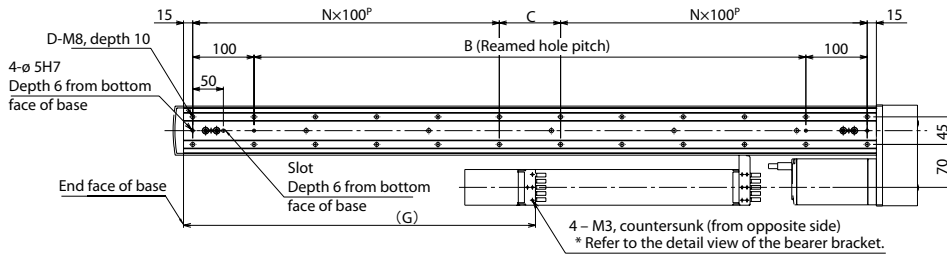

Detail view of X-axis installation



Detail view of slot in bottom face of X-axis base

■ Dimensions by Stroke

X: Nominal stroke	250	300	350	400	450	500	550	600	650	700	750	800	850	900	950	1000
X: Effective stroke	50	100	150	200	250	300	350	400	450	500	550	600	650	700	750	800
B	250	300	350	400	450	500	550	600	650	700	750	800	850	900	950	1000
C	50	100	150	0	50	100	150	0	50	100	150	0	50	100	150	0
D	12	12	12	14	16	16	16	18	20	20	20	22	24	24	24	26
N	2	2	2	3	3	3	3	4	4	4	4	5	5	5	5	6
G	-	-	299	324	349	374	399	424	449	474	499	524	549	574	599	624

* A bearer is not set when the X stroke is 50 or 100.

Controllers

Applicable controller



Refer to P. 91 for the controllers.

IK2-PYBB1□□S

RCP2 2-axis Combinations Y axis: SS8R (Reversed, Double-slider)
Z axis: SA7R (Reversed)

Model Details

Series: IK2 — Type: PYBB1□□S — Encoder type: I — Axis 1 (Y axis): — Axis 2 (Z axis): — Controllers: P1 — Cable: — Shipping configuration: K

Combination directions 1-2
Differences between Single-slider and Double-slider Types
HH: Y high-speed, Z high-speed
HM: Y high-speed, Z medium-speed
HL: Y high-speed, Z low-speed

Encoder type
I: Incremental

Stroke (mm)
5: 50mm }
(Can be set in 50-mm increments)

Options
B: Brake
NM: Opposite-home specification
SR: Slider roller specification

Cable length
1L: 1m
3L: 3m
5L: 5m
□L: □m

Wiring 1
N: Cable only
CT: With cable track

Wiring 2
K: Individual components (kit)

* Refer to P.10 for details on the items comprising the model name.

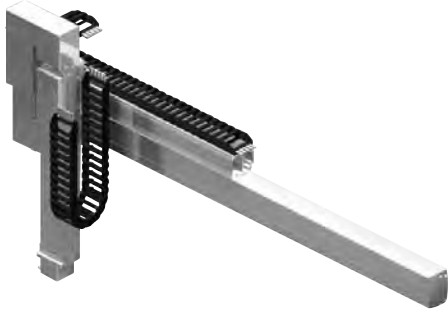

Both wiring 1 and wiring 2 assume use of a cable track.

Maximum Stroke

Y axis 1000 mm

Z axis 300 mm

Maximum Speed (High-speed type)

Y axis 250 mm/s

Z axis 360 mm/s

Maximum Load Capacity

Z-axis stroke	Z high-speed, lead 16	Z medium-speed, lead 8	Z low-speed, lead 4
50mm	2.0kg	4.0kg	8.0kg
100mm	2.0kg	4.0kg	8.0kg
150mm	2.0kg	3.5kg	7.0kg
200mm	2.0kg	3.5kg	7.0kg
250mm	1.5kg	3.0kg	6.0kg
300mm	1.5kg	3.0kg	5.5kg

List by Stroke

Z-axis stroke	Incremental					
	50	100	150	200	250	300
50	-	-	-	-	-	-
100	-	-	-	-	-	-
150	-	-	-	-	-	-
200	-	-	-	-	-	-
250	-	-	-	-	-	-
300	-	-	-	-	-	-
350	-	-	-	-	-	-
400	-	-	-	-	-	-
450	-	-	-	-	-	-
500	-	-	-	-	-	-
550	-	-	-	-	-	-
600	-	-	-	-	-	-
650	-	-	-	-	-	-
700	-	-	-	-	-	-
750	-	-	-	-	-	-
800	-	-	-	-	-	-
850	-	-	-	-	-	-
900	-	-	-	-	-	-
950	-	-	-	-	-	-
1000	-	-	-	-	-	-

Cable track

Wiring 1 (Next to Y-axis)	Y-axis stroke	50-300	350-600	650-900	950-1000
Wiring 2 (Next to Z-axis)	Z-axis stroke	50-200	250-300	-	-

List by Cable Length

Type	Cable code	Length
Standard type	1L	1m
	3L	3m
	5L	5m

* Axis 1 comes with a standard cable, while axis 2 comes with a robot cable.
* Refer to P.90 for lengths other than those specified above.

List of Options

Name	Option code	
Opposite-home specification	NM	
Slider roller specification	SR	Axis 1 (Y-axis) Axis 2 (Z-axis)

Specifications

Item	Y axis	Z axis
Axis model	RCP2-SS8R	RCP2-SA7R
Stroke (Can be set in 50-mm increments)	50-1000mm	50-300mm
Max speed	High-speed type: 250mm/s	High-speed type: 360mm/s Medium-speed type: 180mm/s Low-speed type: 90mm/s
Motor size	56-square pulse motor	
Ball screw lead	High-speed type: 20mm	High-speed type: 16mm Medium-speed type: 8mm Low-speed type: 4mm
Drive method	Ball screw, ø16mm, rolled, C10	Ball screw, ø12mm, rolled, C10
Positioning repeatability	±0.02mm	
Base material	Dedicated alloy steel / Aluminum	
Surrounding air temperature/humidity	0 to 40°C, 85% RH or below (non-condensing)	

Dimensions

You can download CAD drawings from our website. www.intelligentactuator.com



Note 1. The connected position shown in the drawing defines the home.
 Note 2. Both wiring 1 and wiring 2 assume use of a cable track.
 Note 3. For details on the cable track, refer to P.90.
 Note 4. For details on the bracket on the moving end of the cable track, refer to P.90.

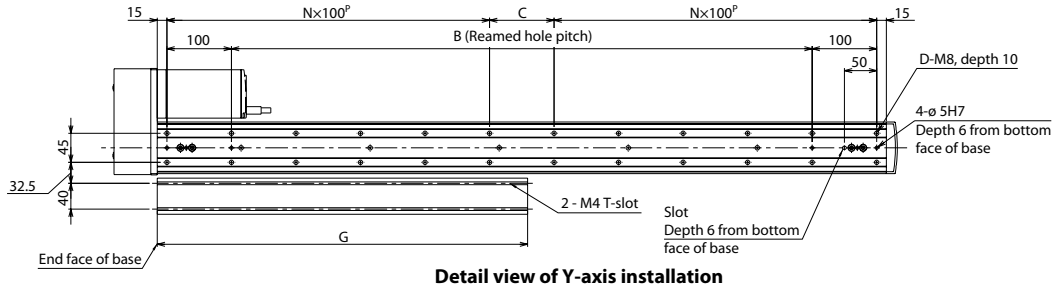

Detail view of Y-axis installation

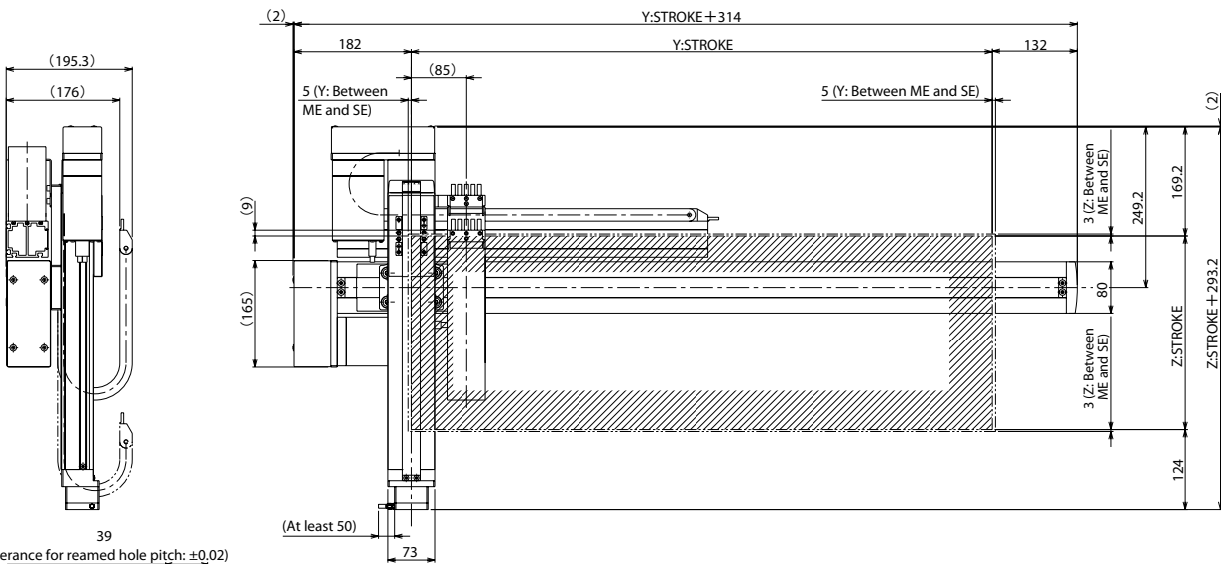
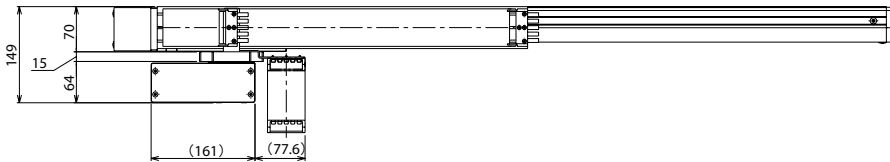

ME: Mechanical end
 SE: Stroke end

* Caution

Customer to prepare the parts and attach Y-axis cable track guide rail to the same plane the Y-axis actuator is installed. Also customer to prepare the parts and attach Z-axis cable track free end (Z-axis slider side) to the customer's bracket on the Z-axis slider.

(Tolerance for reamed hole pitch: ±0.02)

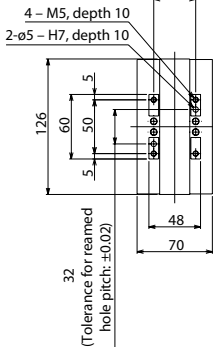

Detail view of Z-axis slider Detail view of slot in bottom face of Y-axis base

■ Dimensions by Stroke

Y: Model	50	100	150	200	250	300	350	400	450	500	550	600	650	700	750	800	850	900	950	1000
B	50	100	150	200	250	300	350	400	450	500	550	600	650	700	750	800	850	900	950	1000
C	50	100	150	0	50	100	150	0	50	100	150	0	50	100	150	0	50	100	150	0
D	8	8	8	10	12	12	12	14	16	16	16	18	20	20	20	22	24	24	24	26
N	1	1	1	2	2	2	2	3	3	3	3	4	4	4	4	5	5	5	5	6
G	149	174	199	224	249	274	299	324	349	374	399	424	449	474	499	524	549	574	599	624

Controllers

Applicable controller



Refer to P. 91 for the controllers.

IK2-SXBD1□□S

RCS2 2-axis Combinations X axis: SS7R (Reversed, Single-slider)
Y axis: SA5R (Reversed)

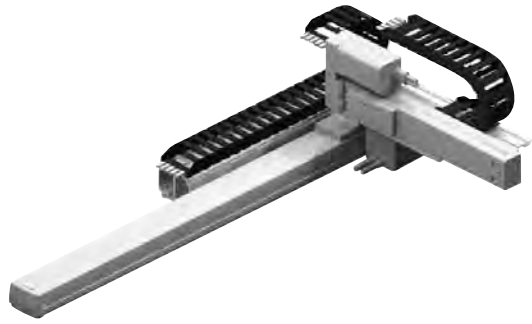
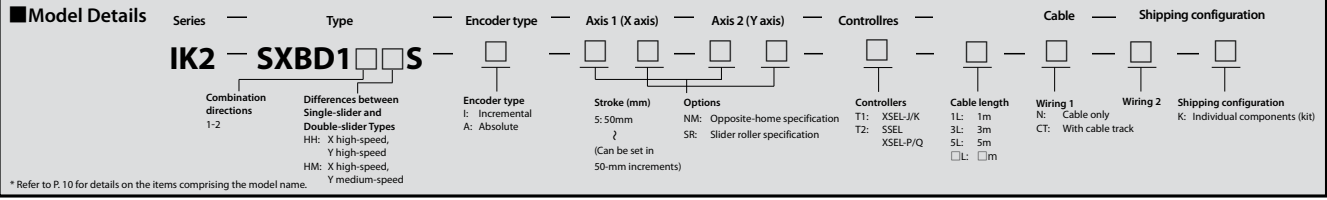

Both wiring 1 and wiring 2 assume use of a cable track.

Maximum Stroke

X axis 600 mm **Y axis** 200 mm

Maximum Speed

	High-speed type	Medium-speed type
X axis	600mm/s	—
Y axis	800mm/s	400mm/s

Maximum Load Capacity

Y-axis stroke	X high-speed, Y high-speed	X high-speed, Y medium-speed
50mm	3.0kg	6.0kg
100mm	3.0kg	6.0kg
150mm	2.5kg	5.0kg
200mm	2.5kg	5.0kg

List by Stroke

Y-axis stroke		Incremental				Absolute			
		50	100	150	200	50	100	150	200
X-axis stroke	50	—	—	—	—	—	—	—	—
	100	—	—	—	—	—	—	—	—
	150	—	—	—	—	—	—	—	—
	200	—	—	—	—	—	—	—	—
	250	—	—	—	—	—	—	—	—
	300	—	—	—	—	—	—	—	—
	350	—	—	—	—	—	—	—	—
	400	—	—	—	—	—	—	—	—
	450	—	—	—	—	—	—	—	—
	500	—	—	—	—	—	—	—	—
	550	—	—	—	—	—	—	—	—
	600	—	—	—	—	—	—	—	—

Cable track

Wiring	X-axis stroke	50-300	350-600
Wiring 1 (Next to X-axis)	Y-axis stroke	—	—
Wiring 2 (Next to Y-axis)	X-axis stroke	50-200	—
	Y-axis stroke	—	—

List by Cable Length

Type	Cable code	Length
Standard type	1L	1m
	3L	3m
	5L	5m

* Axis 1 comes with a standard cable, while axis 2 comes with a robot cable.

* Refer to P. 90 for lengths other than those specified above.

List of Options

Name	Option code
Opposite-home specification	NM
Slider roller specification	SR

Specifications

Item	X axis	Y axis
Axis model	RCS2-SS7R	RCS2-SA5R
Stroke (Can be set in 50-mm increments)	50-600mm	50-200mm
Max speed	Stroke	50-200mm
	High speed	800mm/s
	Medium speed	400mm/s
Motor output (W)	60W	20W
Ball screw lead	High-speed type: 12mm	High-speed type: 12mm Medium-speed type: 6mm
Drive method	Ball screw, ø10 mm, rolled, C10	
Positioning repeatability	±0.02mm	
Base material	Dedicated alloy steel	Aluminum
Surrounding air temperature/humidity	0 to 40°C, 85% RH or below (non-condensing)	

Dimensions

You can download CAD drawings from our website. www.intelligentactuator.com

2D CAD

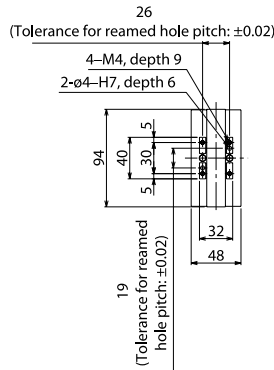
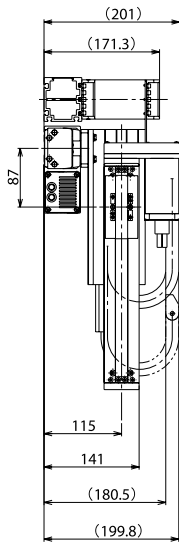

Detail view of Y-axis slider

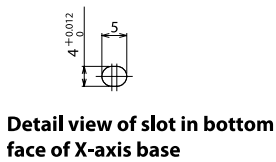

Detail view of slot in bottom face of X-axis base

* Caution

Customer to prepare the parts and attach the X-axis cable track guide rail to the same plane the X-axis actuator is installed. Also customer to prepare the parts and attach the Y-axis cable track free end (Y-axis slider side) to the customer's bracket on the Y-axis slider.

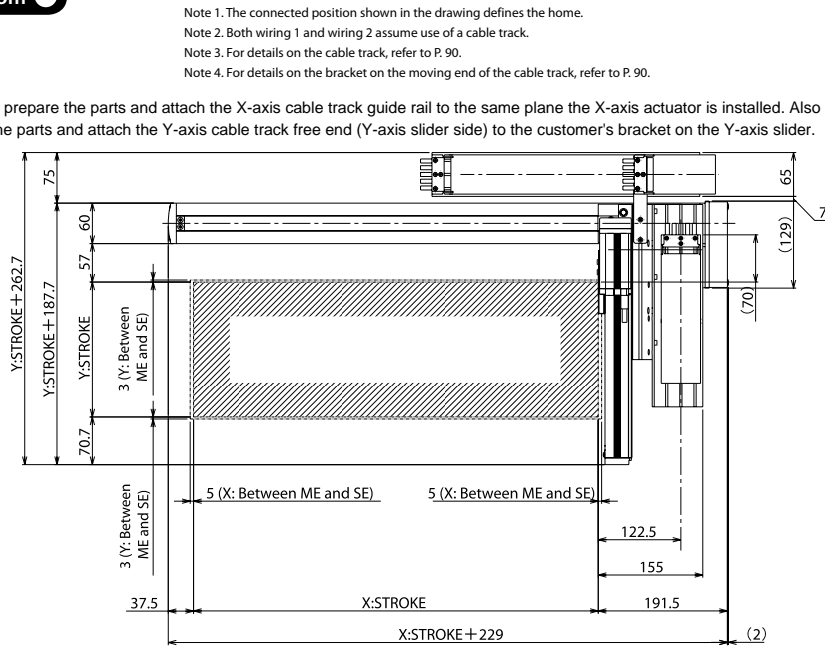

ME: Mechanical end
SE: Stroke end

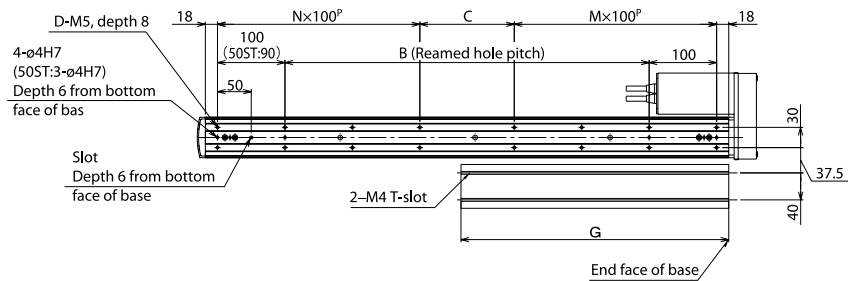
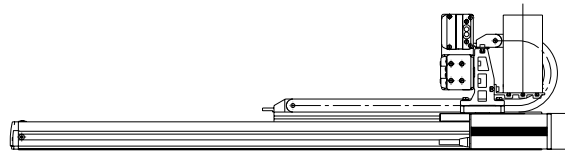

Detail view of X-axis installation

■ Dimensions by Stroke

X: Nominal stroke	50	100	150	200	250	300	350	400	450	500	550	600
B	0	40	90	140	190	240	290	340	390	440	490	540
C	90	40	90	140	190	40	90	140	190	40	90	140
D	6	8	8	8	8	12	12	12	12	16	16	16
M	1	1	1	1	1	2	2	2	2	3	3	3
N	0	1	1	1	1	2	2	2	2	3	3	3
G	122	147	172	197	222	247	272	297	322	347	372	397

Controllers

Applicable controller



Refer to P. 91 for the controllers.

IK2-SXBD1□□D

RCS2 2-axis Combinations X axis: SS7R (Reversed, Double-slider)
Y axis: SA5R (Reversed)

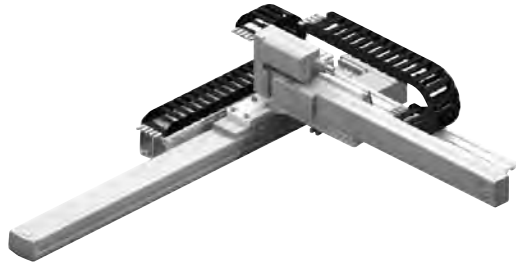
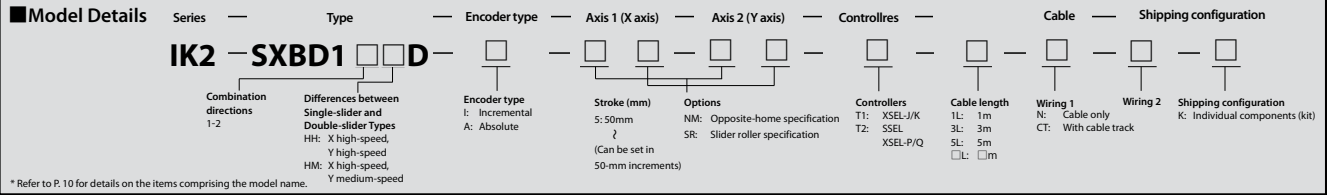

Both wiring 1 and wiring 2 assume use of a cable track.

Maximum Stroke

X axis 450 mm

Y axis 400 mm

Maximum Speed

	High-speed type	Medium-speed type
X axis	600mm/s	—
Y axis	800mm/s	400mm/s

Maximum Load Capacity

Y-axis stroke	X high-speed, Y high-speed	X high-speed, Y medium-speed
250mm	2.5kg	5.0kg
300mm	2.0kg	4.0kg
350mm	2.0kg	4.0kg
400mm	2.0kg	4.0kg

List by Stroke

Y-axis stroke	Incremental				Absolute			
	250	300	350	400	250	300	350	400
50	—	—	—	—	—	—	—	—
100	—	—	—	—	—	—	—	—
150	—	—	—	—	—	—	—	—
200	—	—	—	—	—	—	—	—
250	—	—	—	—	—	—	—	—
300	—	—	—	—	—	—	—	—
350	—	—	—	—	—	—	—	—
400	—	—	—	—	—	—	—	—
450	—	—	—	—	—	—	—	—

Cable track

Wiring	Axis	Stroke	Length
Wiring 1 (Next to X-axis)	X-axis stroke	50-300	350-450
	Y-axis stroke	—	—
Wiring 2 (Next to Y-axis)	X-axis stroke	—	—
	Y-axis stroke	250-400	—

List by Cable Length

Type	Cable code	Length
Standard type	1L	1m
	3L	3m
	5L	5m

* Axis 1 comes with a standard cable, while axis 2 comes with a robot cable.

* Refer to P. 90 for lengths other than those specified above.

List of Options

Name	Option code
Opposite-home specification	NM
Slider roller specification	SR

Specifications

Item	X axis	Y axis
Axis model	RCS2-SS7R	RCS2-SA5R
Stroke (Can be set in 50-mm increments)	50-450mm	250-400mm
Max speed	Stroke	250-400mm
	High speed	800mm/s
	Medium speed	400mm/s
Motor output (W)	60W	20W
Ball screw lead	High-speed type: 12mm	High-speed type: 12mm Medium-speed type: 6mm
Drive method	Ball screw, ø10 mm, rolled, C10	
Positioning repeatability	±0.02mm	
Base material	Dedicated alloy steel	Aluminum
Surrounding air temperature/humidity	0 to 40°C, 85% RH or below (non-condensing)	

Dimensions

You can download CAD drawings from our website.

www.intelligentactuator.com

2D CAD

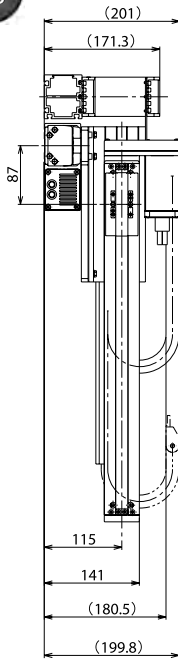

- Note 1. The connected position shown in the drawing defines the home.
- Note 2. Both wiring 1 and wiring 2 assume use of a cable track.
- Note 3. For details on the cable track, refer to P. 90.
- Note 4. For details on the bracket on the moving end of the cable track, refer to P. 90.

* Caution

Customer to prepare the parts and attach the X-axis cable track guide rail to the same plane the X-axis actuator is installed. Also customer to prepare the parts and attach the Y-axis cable track free end (Y-axis slider side) to the customer's bracket on the Y-axis slider.

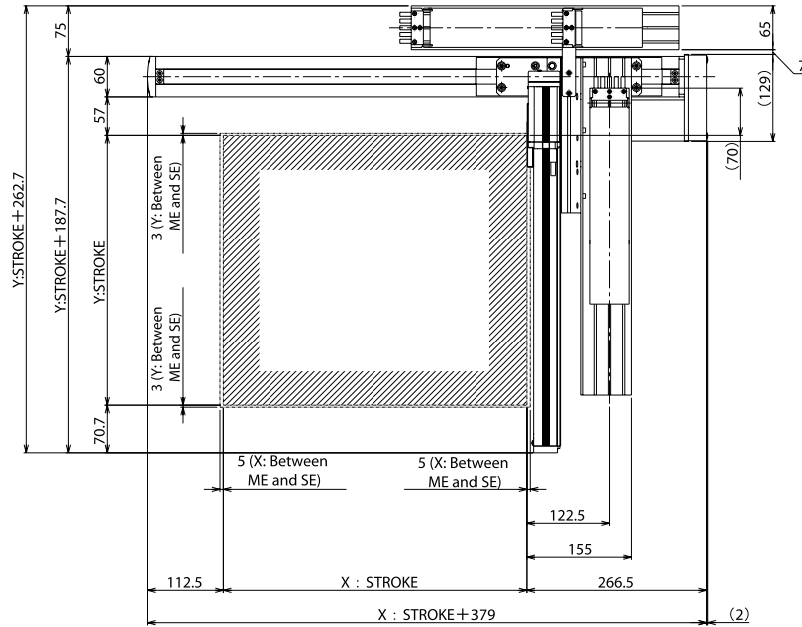

ME: Mechanical end
SE: Stroke end

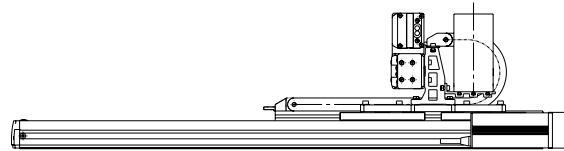

26
(Tolerance for reamed hole pitch: ±0.02)

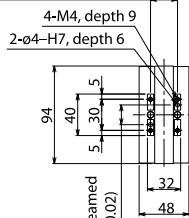

Detail view of Y-axis slider



Detail view of slot in bottom face of X-axis base

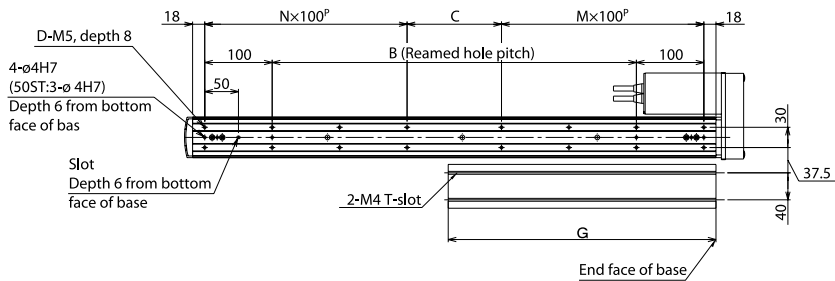

Detail view of X-axis installation

■ Dimensions by Stroke

X: Nominal stroke	200	250	300	350	400	450	500	550	600
X: Effective stroke	50	100	150	200	250	300	350	400	450
B	140	190	240	290	340	390	440	490	540
C	140	190	40	90	140	190	40	90	140
D	8	8	12	12	12	12	16	16	16
M	1	1	2	2	2	2	3	3	3
N	1	1	2	2	2	2	3	3	3
G	197	222	247	272	297	322	347	372	397

Controllers

Applicable controller



Refer to P. 91 for the controllers.

IK2-SXBD2□□S

RCS2 2-axis Combinations X axis: S57C (Reversed, Single-slider)
Y axis: SA5R (Reversed)

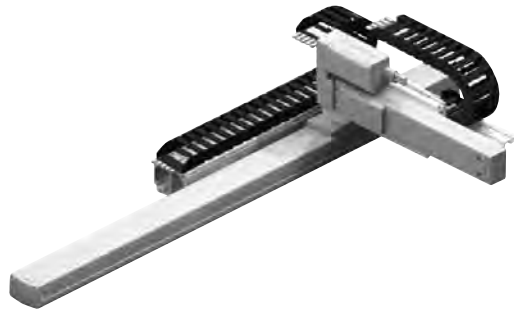
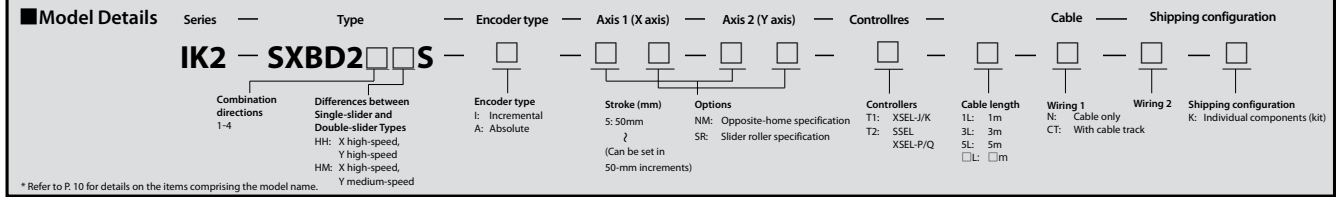

Both wiring 1 and wiring 2 assume use of a cable track.

Maximum Stroke

X axis 600 mm

Y axis 200 mm

Maximum Speed

	High-speed type	Medium-speed type
X axis	600mm/s	—
Y axis	800mm/s	400mm/s

Maximum Load Capacity

Y-axis stroke	X high-speed, Y high-speed	X high-speed, Y medium-speed
50mm	3.0kg	6.0kg
100mm	3.0kg	6.0kg
150mm	2.5kg	5.0kg
200mm	2.5kg	5.0kg

List by Stroke

Y-axis stroke	Incremental				Absolute			
	50	100	150	200	50	100	150	200
50	—	—	—	—	—	—	—	—
100	—	—	—	—	—	—	—	—
150	—	—	—	—	—	—	—	—
200	—	—	—	—	—	—	—	—
250	—	—	—	—	—	—	—	—
300	—	—	—	—	—	—	—	—
350	—	—	—	—	—	—	—	—
400	—	—	—	—	—	—	—	—
450	—	—	—	—	—	—	—	—
500	—	—	—	—	—	—	—	—
550	—	—	—	—	—	—	—	—
600	—	—	—	—	—	—	—	—

Cable track

Wiring	X-axis stroke	50-300	350-600
Wiring 1 (Next to X-axis)	Y-axis stroke	—	—
Wiring 2 (Next to Y-axis)	X-axis stroke	50-200	—
	Y-axis stroke	—	—

List by Cable Length

Type	Cable code	Length
Standard type	1L	1m
	3L	3m
	5L	5m

* Axis 1 comes with a standard cable, while axis 2 comes with a robot cable.

* Refer to P.90 for lengths other than those specified above.

List of Options

Name	Option code	
Opposite-home specification	NM	
Slider roller specification	SR	Axis 1 (X-axis) Axis 2 (Y-axis)

Specifications

Item	X axis	Y axis
Axis model	RCS2-S57C	RCS2-SA5R
Stroke (Can be set in 50-mm increments)	50-600mm	50-200mm
Max speed	Stroke	50-500mm 600mm/s
	High speed	550-600mm 470mm/s
	Medium speed	—
Motor output (W)	60W	20W
Ball screw lead	High-speed type: 12mm	High-speed type: 12mm Medium-speed type: 6mm
Drive method	Ball screw, ø10 mm, rolled, C10	
Positioning repeatability	±0.02mm	
Base material	Dedicated alloy steel	Aluminum
Surrounding air temperature/humidity	0 to 40°C, 85% RH or below (non-condensing)	

Dimensions

You can download CAD drawings from our website. www.intelligentactuator.com

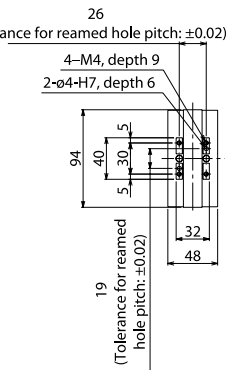
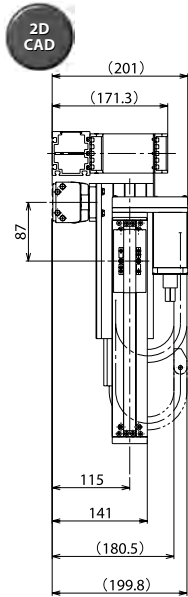

Detail view of Y-axis slider



Detail view of slot in bottom face of X-axis base

Note 1. The connected position shown in the drawing defines the home.
 Note 2. Both wiring 1 and wiring 2 assume use of a cable track.
 Note 3. For details on the cable track, refer to P.90.
 Note 4. For details on the bracket on the moving end of the cable track, refer to P.90.

* Caution

Customer to prepare the parts and attach the X-axis cable track guide rail to the same plane the X-axis actuator is installed. Also customer to prepare the parts and attach the Y-axis cable track free end (Y-axis slider side) to the customer's bracket on the Y-axis slider.

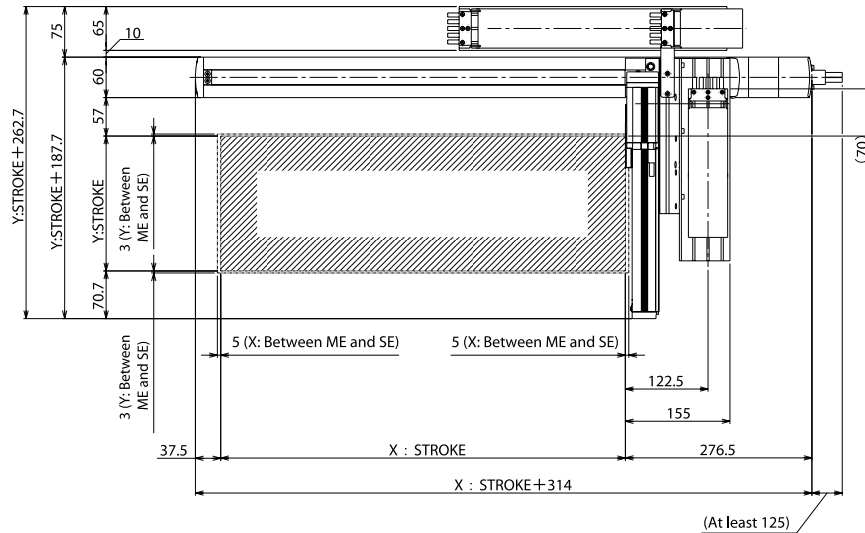

ME: Mechanical end
 SE: Stroke end

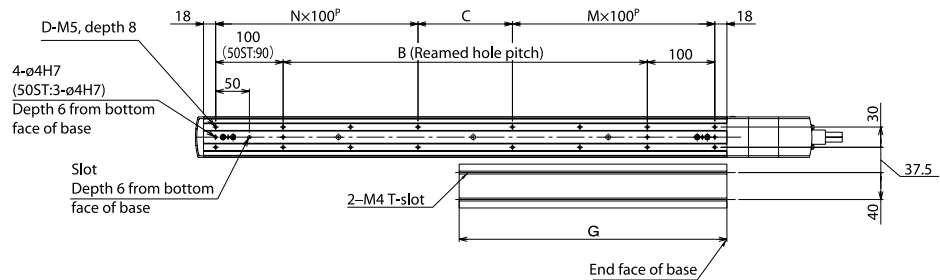
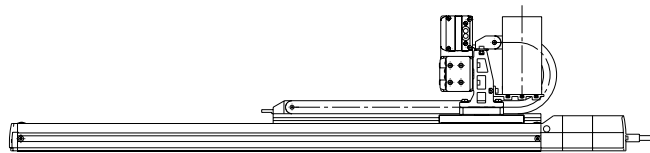

Detail view of X-axis installation

■ Dimensions by Stroke

X: Nominal stroke	50	100	150	200	250	300	350	400	450	500	550	600
B	0	40	90	140	190	240	290	340	390	440	490	540
C	90	40	90	140	190	40	90	140	190	40	90	140
D	6	8	8	8	8	12	12	12	12	16	16	16
M	1	1	1	1	1	2	2	2	2	3	3	3
N	0	1	1	1	1	2	2	2	2	3	3	3
G	122	147	172	197	222	247	272	297	322	347	372	397

Controllers

Applicable controller

Refer to P. 91 for the controllers.

IK2-SXBD2□□D

RCS2 2-axis Combinations X axis: SS7C (Straight, Double-slider) Y axis: SA5R (Reversed)

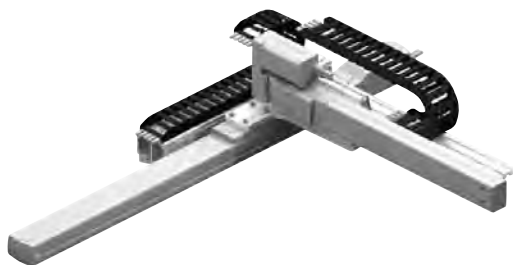
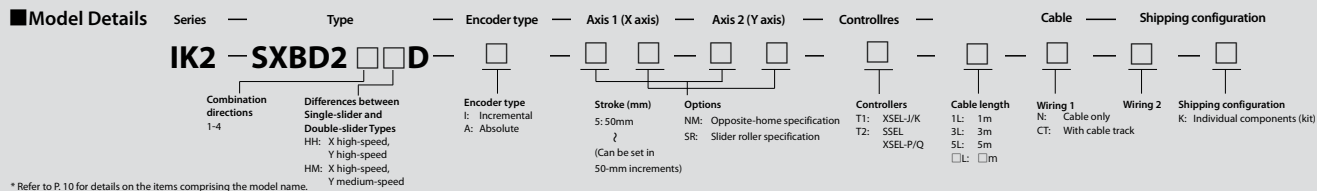

Both wiring 1 and wiring 2 assume use of a cable track.

Maximum Stroke

X axis 450 mm

Y axis 400 mm

Maximum Speed

	High-speed type	Medium-speed type
X axis	600mm/s	-
Y axis	800mm/s	400mm/s

Maximum Load Capacity

Y-axis stroke	X high-speed, Y high-speed	X high-speed, Y medium-speed
250mm	2.5kg	5.0kg
300mm	2.0kg	4.0kg
350mm	2.0kg	4.0kg
400mm	2.0kg	4.0kg

List by Stroke

Y-axis stroke	Incremental				Absolute			
	250	300	350	400	250	300	350	400
50	-	-	-	-	-	-	-	-
100	-	-	-	-	-	-	-	-
150	-	-	-	-	-	-	-	-
200	-	-	-	-	-	-	-	-
250	-	-	-	-	-	-	-	-
300	-	-	-	-	-	-	-	-
350	-	-	-	-	-	-	-	-
400	-	-	-	-	-	-	-	-
450	-	-	-	-	-	-	-	-

Cable track

	X-axis stroke	50-300	350-450
Wiring 1 (Next to X-axis)	X-axis stroke	-	-
Wiring 2 (Next to Y-axis)	Y-axis stroke	250-400	-

List by Cable Length

Type	Cable code	Length
Standard type	1L	1m
	3L	3m
	5L	5m

* Axis 1 comes with a standard cable, while axis 2 comes with a robot cable.

* Refer to P. 90 for lengths other than those specified above.

List of Options

Name	Option code	
Opposite-home specification	NM	
Slider roller specification	SR	Axis 1 (X-axis) Axis 2 (Y-axis)

Specifications

Item	X axis	Y axis
Axis model	RCS2-SS7C	RCS2-SA5R
Stroke (Can be set in 50-mm increments)	50-450mm	250-400mm
Max speed	Stroke	250-400mm
	High speed	800mm/s
	600mm/s	400mm/s
	400-450mm	
	470mm/s	
	-	
Motor output (W)	60W	20W
Ball screw lead	High-speed type: 12mm	High-speed type: 12mm Medium-speed type: 6mm
Drive method	Ball screw, ø10 mm, rolled, C10	
Positioning repeatability	±0.02mm	
Base material	Dedicated alloy steel	Aluminum
Surrounding air temperature/humidity	0 to 40°C, 85% RH or below (non-condensing)	

Dimensions

You can download CAD drawings from our website. www.intelligentactuator.com

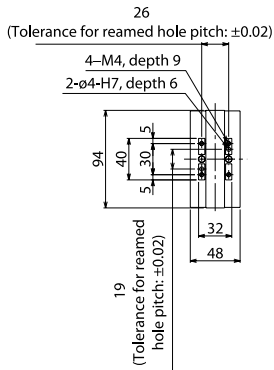
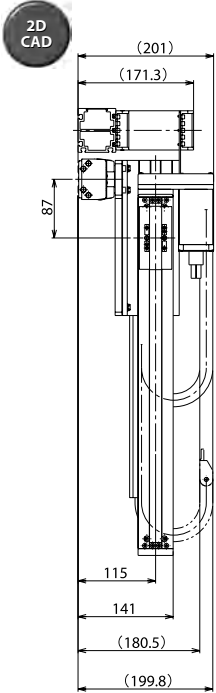

Detail view of Y-axis slider



Detail view of slot in bottom face of X-axis base

* Caution

Customer to prepare the parts and attach the X-axis cable track guide rail to the same plane the X-axis actuator is installed. Also customer to prepare the parts and attach the Y-axis cable track free end (Y-axis slider side) to the customer's bracket on the Y-axis slider.

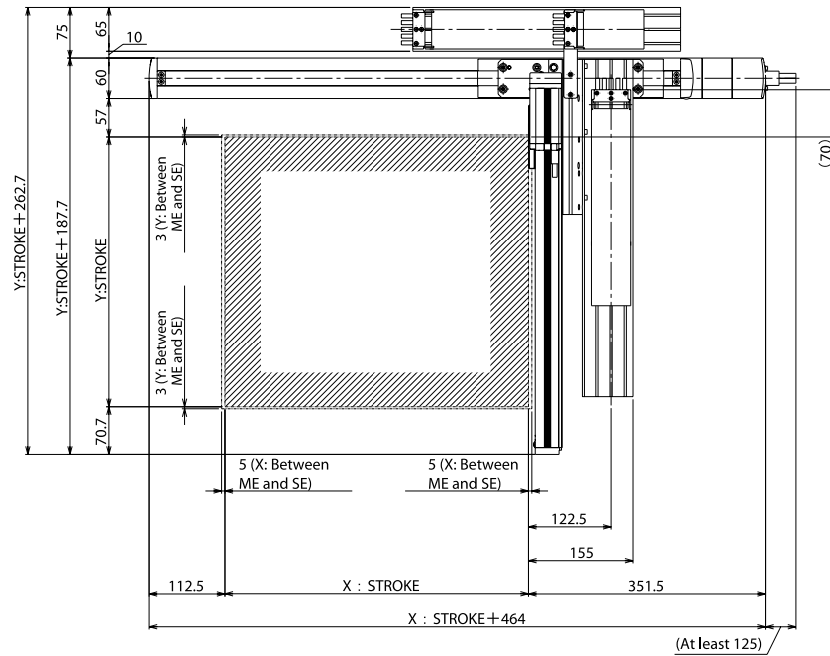

ME: Mechanical end
SE: Stroke end

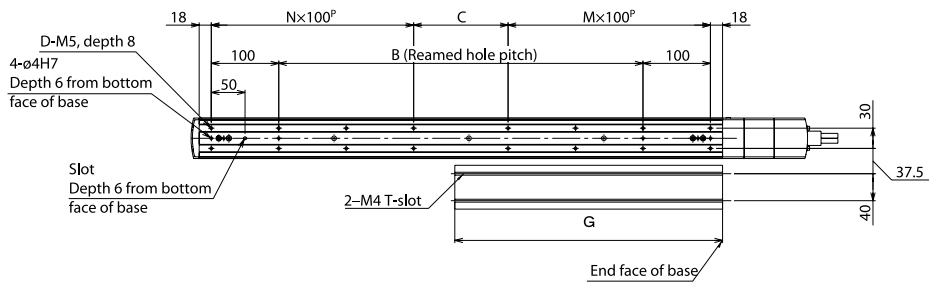
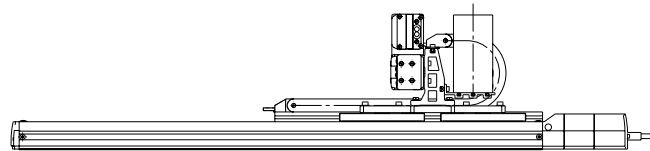

Detail view of X-axis installation

■ Dimensions by Stroke

X: Nominal stroke	200	250	300	350	400	450	500	550	600
X: Effective stroke	50	100	150	200	250	300	350	400	450
B	140	190	240	290	340	390	440	490	540
C	140	190	40	90	140	190	40	90	140
D	8	8	12	12	12	12	16	16	16
M	1	1	2	2	2	2	3	3	3
N	1	1	2	2	2	2	3	3	3
G	197	222	247	272	297	322	347	372	397

Controllers

Applicable controller

Refer to P. 91 for the controllers.

IK2-SXBC1□□S

RCS2 2-axis Combinations X axis: SS7R (Reversed, Single-slider)
Y axis: SA6R (Reversed)

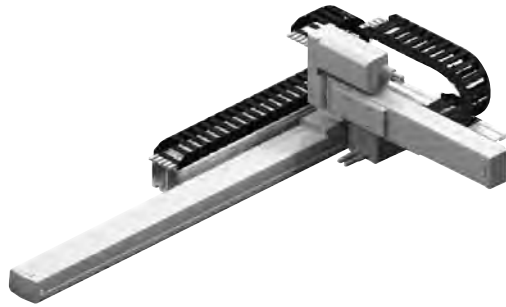
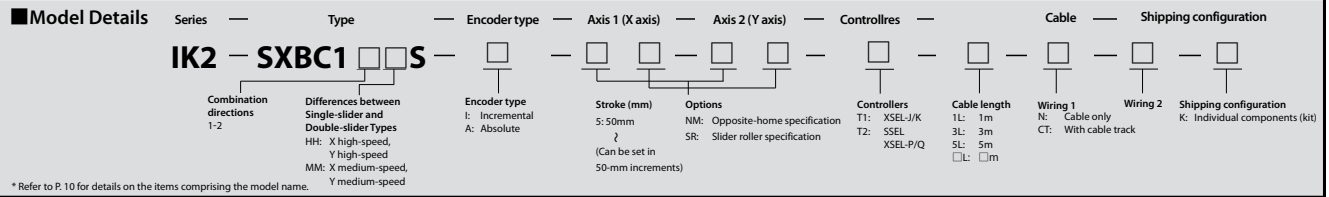

Both wiring 1 and wiring 2 assume use of a cable track.

Maximum Stroke

X axis 600 mm Y axis 200 mm

Maximum Speed

	High-speed type	Medium-speed type
X axis	600mm/s	300mm/s
Y axis	800mm/s	400mm/s

Maximum Load Capacity

Y-axis stroke	X high-speed, Y high-speed	X medium-speed, Y medium-speed
50mm	4.5kg	9.0kg
100mm	4.5kg	9.0kg
150mm	4.0kg	8.0kg
200mm	3.0kg	6.0kg

List by Stroke

Y-axis stroke	Incremental				Absolute			
	50	100	150	200	50	100	150	200
50	-	-	-	-	-	-	-	-
100	-	-	-	-	-	-	-	-
150	-	-	-	-	-	-	-	-
200	-	-	-	-	-	-	-	-
250	-	-	-	-	-	-	-	-
300	-	-	-	-	-	-	-	-
350	-	-	-	-	-	-	-	-
400	-	-	-	-	-	-	-	-
450	-	-	-	-	-	-	-	-
500	-	-	-	-	-	-	-	-
550	-	-	-	-	-	-	-	-
600	-	-	-	-	-	-	-	-

Cable track

Wiring 1 (Next to X-axis)	X-axis stroke	50-300	350-600
Wiring 2 (Next to Y-axis) <th>Y-axis stroke</th> <td>50-200</td> <td>-</td>	Y-axis stroke	50-200	-

List by Cable Length

Type	Cable code	Length
Standard type	1L	1m
	3L	3m
	5L	5m

* Axis 1 comes with a standard cable, while axis 2 comes with a robot cable.

* Refer to P. 90 for lengths other than those specified above.

List of Options

Name	Option code	
Opposite-home specification	NM	
Slider roller specification	SR	Axis 1 (X-axis) Axis 2 (Y-axis)

Specifications

Item	X axis	Y axis
Axis model	RCS2-SS7R	RCS2-SA6R
Stroke (Can be set in 50-mm increments)	50-600mm	50-200mm
Max speed	Stroke	50-500mm
	High speed	600mm/s
	Medium speed	300mm/s
Motor output (W)	60W	30W
Ball screw lead	High-speed type: 12mm Medium-speed type: 6mm	
Drive method	Ball screw, ø10 mm, rolled, C10	
Positioning repeatability	±0.02mm	
Base material	Dedicated alloy steel	Aluminum
Surrounding air temperature/humidity	0 to 40°C, 85% RH or below (non-condensing)	

Dimensions

You can download CAD drawings from our website.

www.intelligentactuator.com

2D CAD

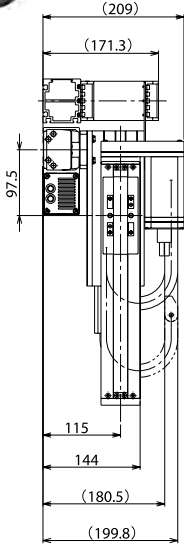

31
(Tolerance for reamed hole pitch: ±0.02)

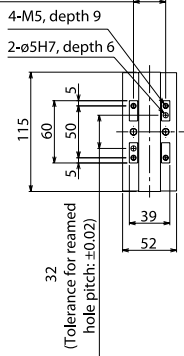

Detail view of Y-axis slider



Detail view of slot in bottom face of X-axis base

- Note 1. The connected position shown in the drawing defines the home.
- Note 2. Both wiring 1 and wiring 2 assume use of a cable track.
- Note 3. For details on the cable track, refer to P. 90.
- Note 4. For details on the bracket on the moving end of the cable track, refer to P. 90.

* Caution

Customer to prepare the parts and attach the X-axis cable track guide rail to the same plane the X-axis actuator is installed. Also customer to prepare the parts and attach the Y-axis cable track free end (Y-axis slider side) to the customer's bracket on the Y-axis slider.

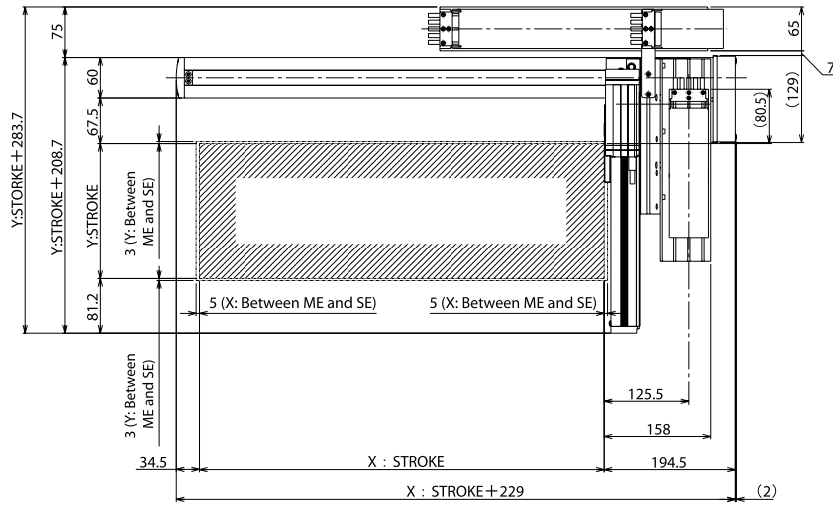

ME: Mechanical end
SE: Stroke end

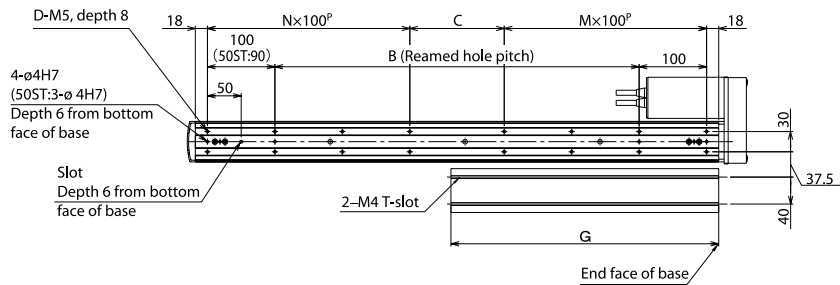
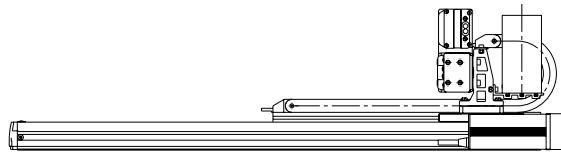

Detail view of X-axis installation

■ Dimensions by Stroke

X: Nominal stroke	50	100	150	200	250	300	350	400	450	500	550	600
B	0	40	90	140	190	240	290	340	390	440	490	540
C	90	40	90	140	190	40	90	140	190	40	90	140
D	6	8	8	8	8	12	12	12	12	16	16	16
M	1	1	1	1	1	2	2	2	2	3	3	3
N	0	1	1	1	1	2	2	2	2	3	3	3
G	122	147	172	197	222	247	272	297	322	347	372	397

Controllers

Applicable controller



Refer to P. 91 for the controllers.

IK2-SXBC1□□D

RCS2 2-axis Combinations X axis: SS7R (Reversed, Double-slider)
Y axis: SA6R (Reversed)

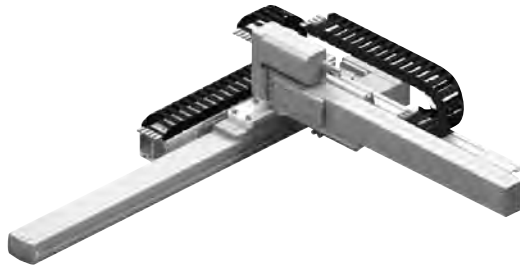
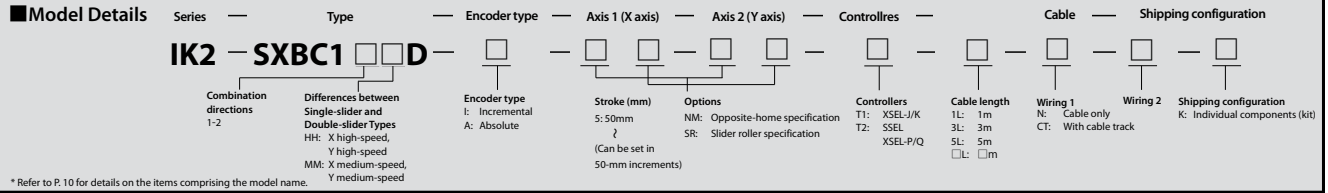

Both wiring 1 and wiring 2 assume use of a cable track.

Maximum Stroke

X axis 450 mm

Y axis 400 mm

Maximum Speed

	High-speed type	Medium-speed type
X axis	600mm/s	300mm/s
Y axis	800mm/s	400mm/s

Maximum Load Capacity

Y-axis stroke	X high-speed, Y high-speed	X medium-speed, Y medium-speed
250mm	3.0kg	6.0kg
300mm	3.0kg	6.0kg
350mm	3.0kg	6.0kg
400mm	3.0kg	6.0kg

List by Stroke

Y-axis stroke	Incremental				Absolute			
	250	300	350	400	250	300	350	400
50	-	-	-	-	-	-	-	-
100	-	-	-	-	-	-	-	-
150	-	-	-	-	-	-	-	-
200	-	-	-	-	-	-	-	-
250	-	-	-	-	-	-	-	-
300	-	-	-	-	-	-	-	-
350	-	-	-	-	-	-	-	-
400	-	-	-	-	-	-	-	-
450	-	-	-	-	-	-	-	-

Cable track

	X-axis stroke	50-300	350-450
Wiring 1 (Next to X-axis)			
Wiring 2 (Next to Y-axis)	Y-axis stroke	250-400	-

List by Cable Length

Type	Cable code	Length
Standard type	1L	1m
	3L	3m
	5L	5m

* Axis 1 comes with a standard cable, while axis 2 comes with a robot cable.
* Refer to P. 90 for lengths other than those specified above.

List of Options

Name	Option code	
Opposite-home specification	NM	
Slider roller specification	SR	Axis 1 (X-axis) Axis 2 (Y-axis)

Specifications

Item	X axis	Y axis	
Axis model	RCS2-SS7R	RCS2-SA6R	
Stroke (Can be set in 50-mm increments)	50-450mm	250-400mm	
Max speed	Stroke	250-400mm	
	High speed	600mm/s	800mm/s
	Medium speed	300mm/s	400mm/s
Motor output (W)	60W	30W	
Ball screw lead	High-speed type: 12mm Medium-speed type: 6mm		
Drive method	Ball screw, ø10 mm, rolled, C10		
Positioning repeatability	±0.02mm		
Base material	Dedicated alloy steel	Aluminum	
Surrounding air temperature/humidity	0 to 40°C, 85% RH or below (non-condensing)		

Dimensions

You can download CAD drawings from our website.

www.intelligentactuator.com

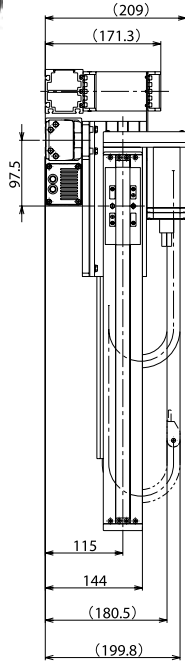

* Caution

Customer to prepare the parts and attach the X-axis cable track guide rail to the same plane the X-axis actuator is installed. Also customer to prepare the parts and attach the Y-axis cable track free end (Y-axis slider side) to the customer's bracket on the Y-axis slider.

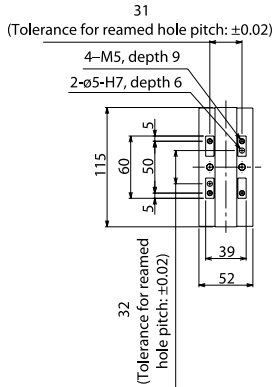
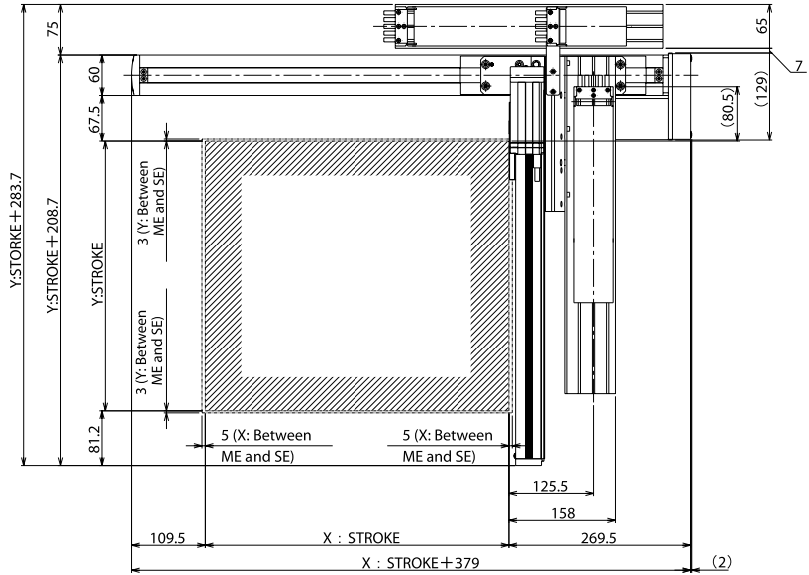

Detail view of Y-axis slider



Detail view of slot in bottom face of X-axis base

ME: Mechanical end
SE: Stroke end

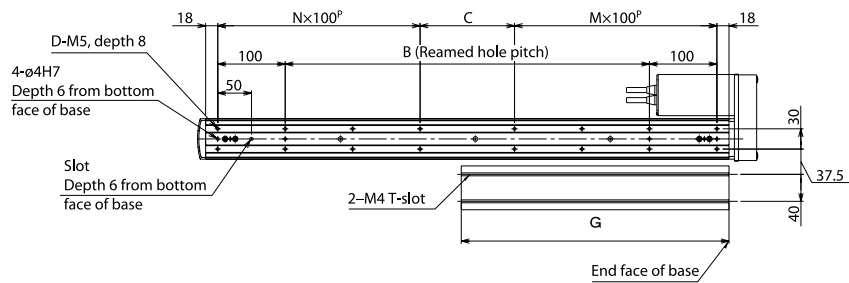
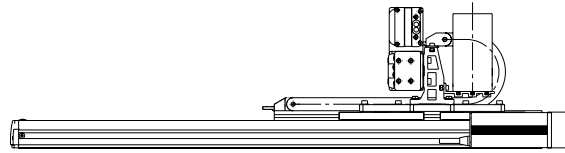

Detail view of X-axis installation

■ Dimensions by Stroke

X: Nominal stroke	200	250	300	350	400	450	500	550	600
X: Effective stroke	50	100	150	200	250	300	350	400	450
B	140	190	240	290	340	390	440	490	540
C	140	190	40	90	140	190	40	90	140
D	8	8	12	12	12	12	16	16	16
M	1	1	2	2	2	2	3	3	3
N	1	1	2	2	2	2	3	3	3
G	197	222	247	272	297	322	347	372	397

Controllers

Applicable controller



Refer to P. 91 for the controllers.

IK2-SXBC2□□S

RCS2 2-axis Combinations X axis: SS7C (Straight, Single-slider)
Y axis: SA6R (Reversed)

Model Details

Series: IK2 — Type: SXBC2□□S — Encoder type: □ — Axis 1 (X axis): □ — Axis 2 (Y axis): □ — Controllres: □ — Cable: □ — Shipping configuration: □

Combination directions 1-4

Differences between Single-slider and Double-slider Types
 HH: X high-speed, Y high-speed
 MM: X medium-speed, Y medium-speed

Encoder type
 I: Incremental
 A: Absolute

Stroke (mm)
 5: 50mm
 ? (Can be set in 50-mm increments)

Options
 NM: Opposite-home specification
 SR: Slider roller specification

Controllers
 T1: XSEL-J/K
 T2: SSEL
 XSEL-P/Q

Cable length
 1L: 1m
 3L: 3m
 5L: 5m
 □L: □m

Wiring 1
 N: Cable only
 CT: With cable track

Wiring 2
 K: Individual components (kit)

Shipping configuration
 K: Individual components (kit)

* Refer to P.10 for details on the items comprising the model name.

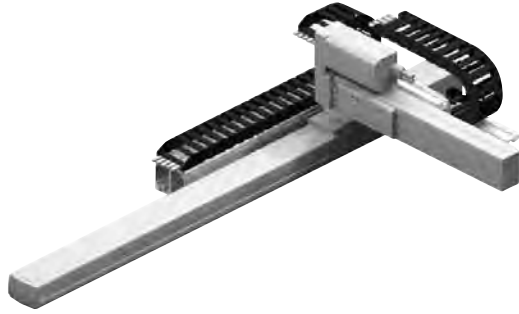

Both wiring 1 and wiring 2 assume use of a cable track.

Maximum Stroke

X axis 600 mm

Y axis 200 mm

Maximum Speed

	High-speed type	Medium-speed type
X axis	600mm/s	300mm/s
Y axis	800mm/s	400mm/s

Maximum Load Capacity

Y-axis stroke	X high-speed, Y high-speed	X medium-speed, Y medium-speed
50mm	4.5kg	9.0kg
100mm	4.5kg	9.0kg
150mm	4.0kg	8.0kg
200mm	3.0kg	6.0kg

List by Stroke

Y-axis stroke	Incremental				Absolute			
	50	100	150	200	50	100	150	200
50	-	-	-	-	-	-	-	-
100	-	-	-	-	-	-	-	-
150	-	-	-	-	-	-	-	-
200	-	-	-	-	-	-	-	-
250	-	-	-	-	-	-	-	-
300	-	-	-	-	-	-	-	-
350	-	-	-	-	-	-	-	-
400	-	-	-	-	-	-	-	-
450	-	-	-	-	-	-	-	-
500	-	-	-	-	-	-	-	-
550	-	-	-	-	-	-	-	-
600	-	-	-	-	-	-	-	-

Cable track

Wiring	X-axis stroke	50-300	350-600
Wiring 1 (Next to X-axis)	Y-axis stroke	50-200	-
Wiring 2 (Next to Y-axis)	X-axis stroke	-	50-300
	Y-axis stroke	-	350-600

List by Cable Length

Type	Cable code	Length
Standard type	1L	1m
	3L	3m
	5L	5m

* Axis 1 comes with a standard cable, while axis 2 comes with a robot cable.
 * Refer to P.90 for lengths other than those specified above.

List of Options

Name	Option code	
Opposite-home specification	NM	
Slider roller specification	SR	Axis 1 (X-axis) Axis 2 (Y-axis)

Specifications

Item	X axis	Y axis	
Axis model	RCS2-SS7C	RCS2-SA6R	
Stroke (Can be set in 50-mm increments)	50-600mm	50-200mm	
Max speed	Stroke	50-200mm	
	High speed	600mm/s	800mm/s
	Medium speed	470mm/s 230mm/s	400mm/s
Motor output (W)	60W	30W	
Ball screw lead	High-speed type: 12mm Medium-speed type: 6mm		
Drive method	Ball screw, ø10 mm, rolled, C10		
Positioning repeatability	±0.02mm		
Base material	Dedicated alloy steel	Aluminum	
Surrounding air temperature/humidity	0 to 40°C, 85% RH or below (non-condensing)		

Dimensions

You can download CAD drawings from our website.

www.intelligentactuator.com

Note 1. The connected position shown in the drawing defines the home.

Note 2. Both wiring 1 and wiring 2 assume use of a cable track.

Note 3. For details on the cable track, refer to P. 90.

Note 4. For details on the bracket on the moving end of the cable track, refer to P. 90.

2D CAD

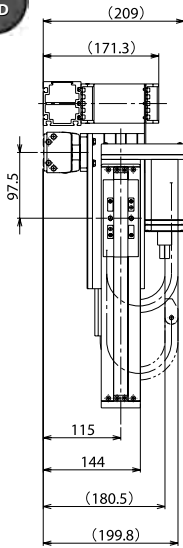

* Caution

Customer to prepare the parts and attach the X-axis cable track guide rail to the same plane the X-axis actuator is installed. Also customer to prepare the parts and attach the Y-axis cable track free end (Y-axis slider side) to the customer's bracket on the Y-axis slider.

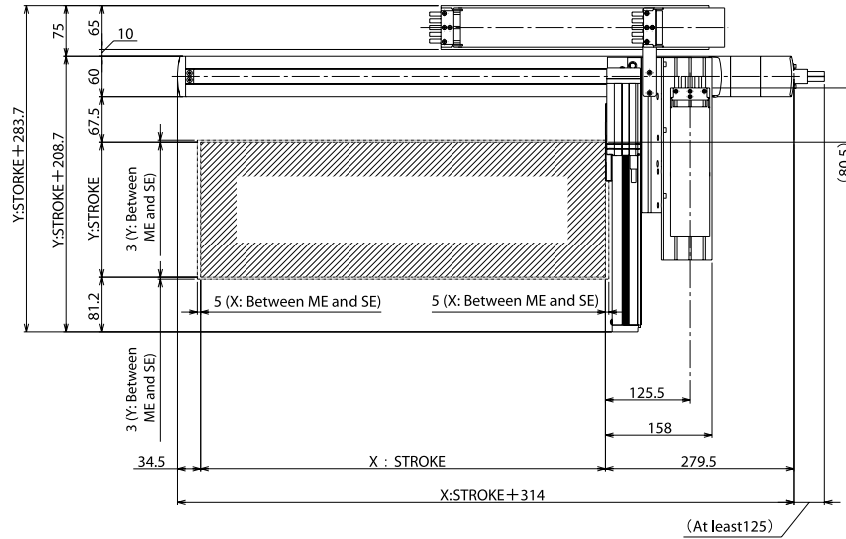

31
(Tolerance for reamed hole pitch: ±0.02)

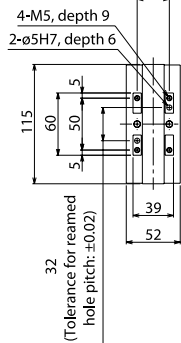

ME: Mechanical end
SE: Stroke end

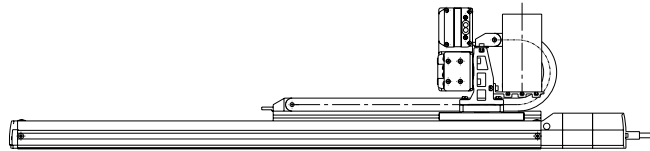

Detail view of Y-axis slider



Detail view of slot in bottom face of X-axis base

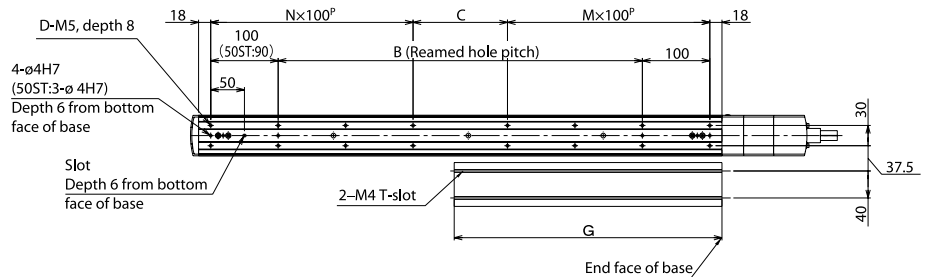

Detail view of X-axis installation

■ Dimensions by Stroke

X: Nominal stroke	50	100	150	200	250	300	350	400	450	500	550	600
B	0	40	90	140	190	240	290	340	390	440	490	540
C	90	40	90	140	190	40	90	140	190	40	90	140
D	6	8	8	8	8	12	12	12	12	16	16	16
M	1	1	1	1	1	2	2	2	2	3	3	3
N	0	1	1	1	1	2	2	2	2	3	3	3
G	122	147	172	197	222	247	272	297	322	347	372	397

Controllers

Applicable controller



Refer to P. 91 for the controllers.

IK2-SXBC2□□D

RCS2 2-axis Combinations X axis: SS7C (Straight, Double-slider)
Y axis: SA6R (Reversed)

Model Details

Series: **IK2** Type: **SXBC2** Encoder type: Encoder type: I: Incremental A: Absolute

Axis 1 (X axis): Stroke (mm): 5: 50mm ? (Can be set in 50-mm increments) Options: NM: Opposite-home specification SR: Slider roller specification

Axis 2 (Y axis): Controllers: T1: XSEL-J/K SSEL T2: XSEL-P/Q

Cable: Cable length: 1L: 1m 3L: 3m 5L: 5m Wiring 1: N: Cable only CT: With cable track

Shipping configuration: Wiring 2: Shipping configuration: K: Individual components (kit)

* Refer to P.10 for details on the items comprising the model name.

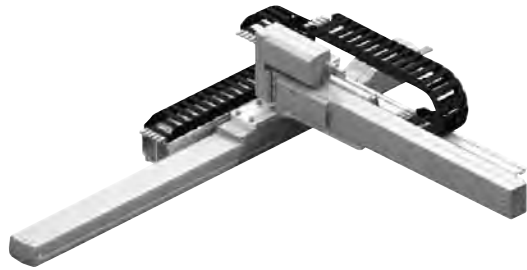

Both wiring 1 and wiring 2 assume use of a cable track.

Maximum Stroke

X axis 450 mm

Y axis 400 mm

Maximum Speed

	High-speed type	Medium-speed type
X axis	600mm/s	300mm/s
Y axis	800mm/s	400mm/s

Maximum Load Capacity

Y-axis stroke	X high-speed, Y high-speed	X medium-speed, Y medium-speed
250mm	3.0kg	6.0kg
300mm	3.0kg	6.0kg
350mm	3.0kg	6.0kg
400mm	3.0kg	6.0kg

List by Stroke

Y-axis stroke	Incremental				Absolute			
	250	300	350	400	250	300	350	400
50	-	-	-	-	-	-	-	-
100	-	-	-	-	-	-	-	-
150	-	-	-	-	-	-	-	-
200	-	-	-	-	-	-	-	-
250	-	-	-	-	-	-	-	-
300	-	-	-	-	-	-	-	-
350	-	-	-	-	-	-	-	-
400	-	-	-	-	-	-	-	-
450	-	-	-	-	-	-	-	-

Cable track

Wiring 1 (Next to X-axis)	X-axis stroke	50-300	350-450
			-
Wiring 2 (Next to Y-axis)	Y-axis stroke	250-400	-
			-

List by Cable Length

Type	Cable code	Length
Standard type	1L	1m
	3L	3m
	5L	5m

* Axis 1 comes with a standard cable, while axis 2 comes with a robot cable.

* Refer to P.90 for lengths other than those specified above.

List of Options

Name	Option code	
Opposite-home specification	NM	
Slider roller specification	SR	Axis 1 (X-axis) Axis 2 (Y-axis)

Specifications

Item	X axis	Y axis	
Axis model	RCS2-SS7C	RCS2-SA6R	
Stroke (Can be set in 50-mm increments)	50-450mm	250-400mm	
Max speed	Stroke	250-400mm	
	High speed	600mm/s	800mm/s
	Medium speed	300mm/s	400mm/s
Motor output (W)	60W	30W	
Ball screw lead	High-speed type: 12mm Medium-speed type: 6mm		
Drive method	Ball screw, ø10 mm, rolled, C10		
Positioning repeatability	±0.02mm		
Base material	Dedicated alloy steel	Aluminum	
Surrounding air temperature/humidity	0 to 40°C, 85% RH or below (non-condensing)		

Dimensions

You can download CAD drawings from our website.

www.intelligentactuator.com

Note 1. The connected position shown in the drawing defines the home.
 Note 2. Both wiring 1 and wiring 2 assume use of a cable track.
 Note 3. For details on the cable track, refer to P. 90.
 Note 4. For details on the bracket on the moving end of the cable track, refer to P. 90.

* Caution

Customer to prepare the parts and attach the X-axis cable track guide rail to the same plane the X-axis actuator is installed. Also customer to prepare the parts and attach the Y-axis cable track free end (Y-axis slider side) to the customer's bracket on the Y-axis slider.

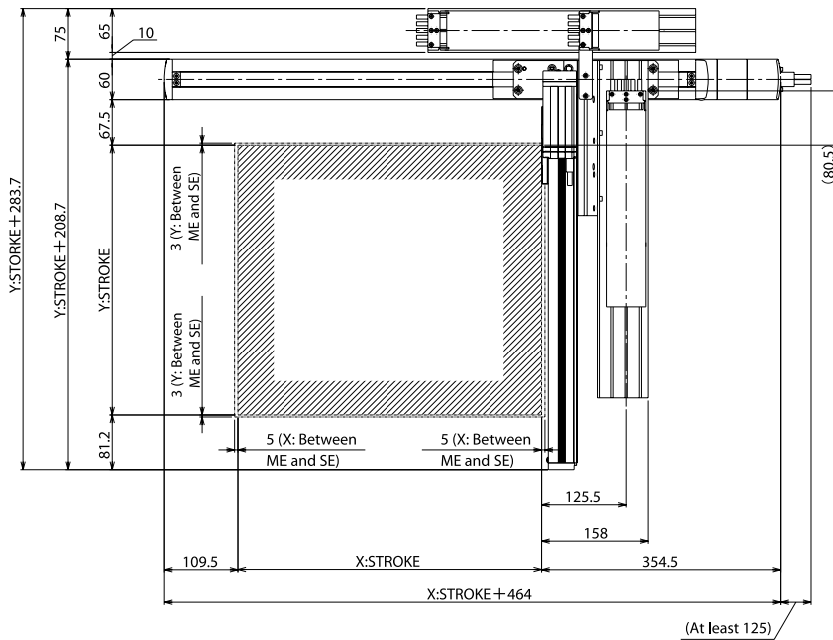
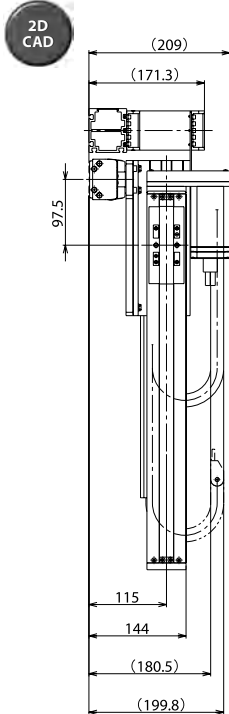

31
 (Tolerance for reamed hole pitch: ±0.02)

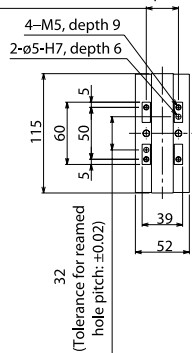

Detail view of Y-axis slider



Detail view of slot in bottom face of X-axis base

ME: Mechanical end
 SE: Stroke end

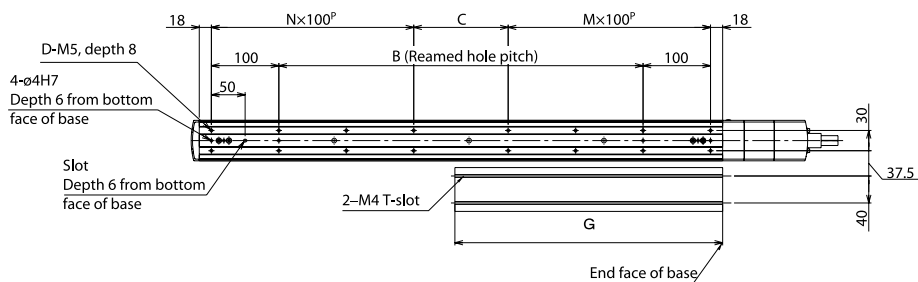
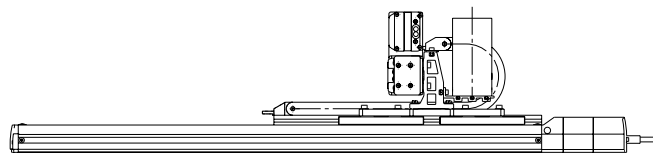

Detail view of X-axis installation

■ Dimensions by Stroke

	200	250	300	350	400	450	500	550	600
X: Nominal stroke	200	250	300	350	400	450	500	550	600
X: Effective stroke	50	100	150	200	250	300	350	400	450
B	140	190	240	290	340	390	440	490	540
C	140	190	40	90	140	190	40	90	140
D	8	8	12	12	12	12	16	16	16
M	1	1	2	2	2	2	3	3	3
N	1	1	2	2	2	2	3	3	3
G	197	222	247	272	297	322	347	372	397

Controllers

Applicable controller



Refer to P. 91 for the controllers.

IK2-SXBB1□□S

RCS2 2-axis Combinations X axis: SS8R (100W, Reversed, Single-slider)
Y axis: SA7R (Reversed)

Model Details

Series: **IK2** Type: **SXBB1□□S** Encoder type: **□** Axis 1 (X axis): **□□□□** Axis 2 (Y axis): **□□□□** Controller: **□** Cable: **□** Shipping configuration: **□**

Combination directions 1-2

Differences between Single-slider and Double-slider Types
 HH: X high-speed, Y high-speed
 MM: X medium-speed, Y medium-speed

Encoder type
 I: Incremental
 A: Absolute

Stroke (mm)
 5: 50mm
 (Can be set in 50-mm increments)

Options
 NM: Opposite-home specification
 SR: Slider roller specification

Controllers
 T1: XSEL-J/K
 T2: SSEL XSEL-P/Q

Cable length
 1L: 1m
 3L: 3m
 5L: 5m
 □L: □m

Wiring 1
 N: Cable only
 CT: With cable track

Wiring 2

Shipping configuration
 K: Individual components (kit)

* Refer to P. 10 for details on the items comprising the model name.



Both wiring 1 and wiring 2 assume use of a cable track.

Maximum Stroke

X axis 1000 mm **Y axis** 300 mm

Maximum Speed

	High-speed type	Medium-speed type
X axis	1000mm/s	500mm/s
Y axis	800mm/s	400mm/s

Maximum Load Capacity

Y-axis stroke	X high-speed, Y high-speed	X medium-speed, Y medium-speed
50mm	8.0kg	16kg
100mm	8.0kg	16kg
150mm	7.0kg	15kg
200mm	7.0kg	12.5kg
250mm	6.0kg	9.0kg
300mm	6.0kg	8.0kg

List by Stroke

Y-axis stroke	Incremental						Absolute					
	50	100	150	200	250	300	50	100	150	200	250	300
50	-	-	-	-	-	-	-	-	-	-	-	-
100	-	-	-	-	-	-	-	-	-	-	-	-
150	-	-	-	-	-	-	-	-	-	-	-	-
200	-	-	-	-	-	-	-	-	-	-	-	-
250	-	-	-	-	-	-	-	-	-	-	-	-
300	-	-	-	-	-	-	-	-	-	-	-	-
350	-	-	-	-	-	-	-	-	-	-	-	-
400	-	-	-	-	-	-	-	-	-	-	-	-
450	-	-	-	-	-	-	-	-	-	-	-	-
500	-	-	-	-	-	-	-	-	-	-	-	-
550	-	-	-	-	-	-	-	-	-	-	-	-
600	-	-	-	-	-	-	-	-	-	-	-	-
650	-	-	-	-	-	-	-	-	-	-	-	-
700	-	-	-	-	-	-	-	-	-	-	-	-
750	-	-	-	-	-	-	-	-	-	-	-	-
800	-	-	-	-	-	-	-	-	-	-	-	-
850	-	-	-	-	-	-	-	-	-	-	-	-
900	-	-	-	-	-	-	-	-	-	-	-	-
950	-	-	-	-	-	-	-	-	-	-	-	-
1000	-	-	-	-	-	-	-	-	-	-	-	-

List by Cable Length

Type	Cable code	Length
Standard type	1L	1m
	3L	3m
	5L	5m

* Axis 1 comes with a standard cable, while axis 2 comes with a robot cable.
 * Refer to P. 90 for lengths other than those specified above.

Cable track

Wiring 1 (Next to X-axis)	X-axis stroke	50-300	350-600	650-900	950-1000
Wiring 2 (Next to Y-axis)	Y-axis stroke	50-200	250-300	-	-

List of Options

Name	Option code
Opposite-home specification	NM
Slider roller specification	SR

Axis 1 (X-axis)
Axis 2 (Y-axis)

Specifications

Item	X axis	Y axis
Axis model	RCS2-SS8R	RCS2-SA7R
Stroke (Can be set in 50-mm increments)	50-1000mm	50-300mm
Max speed	Stroke	50-600mm
	High speed	650-700mm
	Medium speed	750-800mm
Motor output (W)	100W	60W
Ball screw lead	High-speed type: 20mm Medium-speed type: 10mm	High-speed type: 16mm Medium-speed type: 8mm
Drive method	Ball screw, ø16 mm, rolled, C10	Ball screw, ø12 mm, rolled, C10
Positioning repeatability	±0.02mm	
Base material	Dedicated alloy steel	Aluminum
Surrounding air temperature/humidity	0 to 40°C, 85% RH or below (non-condensing)	

Dimensions

You can download CAD drawings from our website.

www.intelligentactuator.com

Note 1. The connected position shown in the drawing defines the home.
 Note 2. Both wiring 1 and wiring 2 assume use of a cable track.
 Note 3. For details on the cable track, refer to P. 90.
 Note 4. For details on the bracket on the moving end of the cable track, refer to P. 90.

* Caution

Customer to prepare the parts and attach the X-axis cable track guide rail to the same plane the X-axis actuator is installed. Also customer to prepare the parts and attach the Y-axis cable track free end (Y-axis slider side) to the customer's bracket on the Y-axis slider.

2D CAD

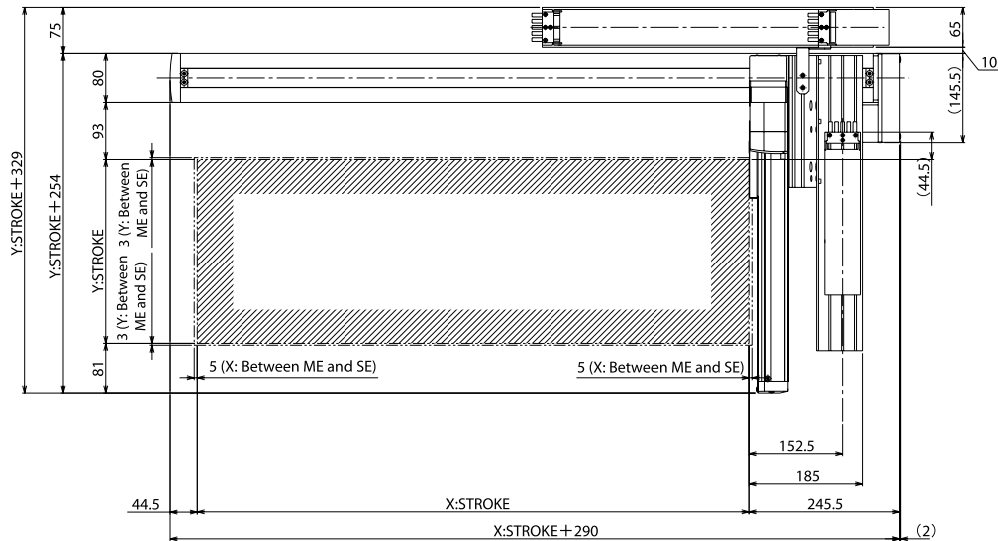
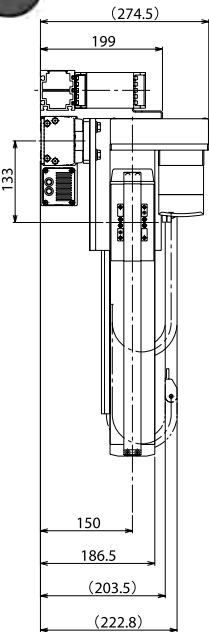

39
 (Tolerance for reamed hole pitch: ±0.02)

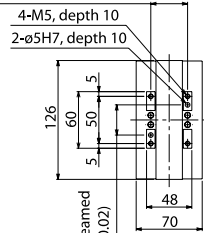

Detail view of Y-axis slider



Detail view of slot in bottom face of X-axis base

ME: Mechanical end
 SE: Stroke end

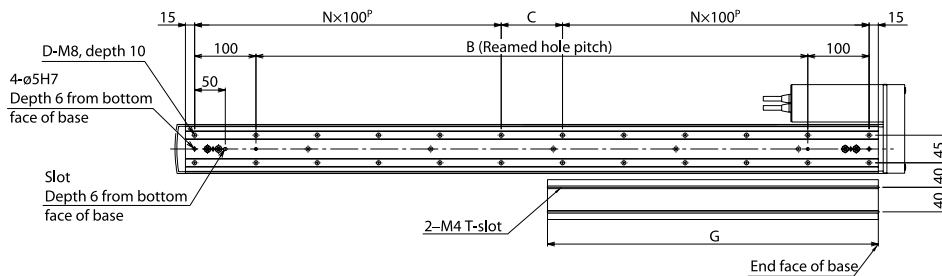
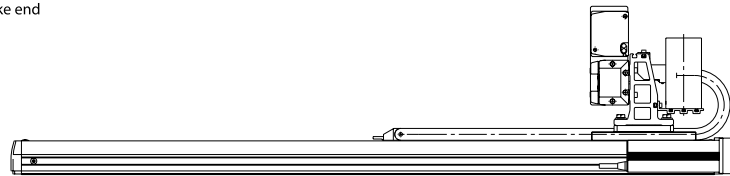

Detail view of X-axis installation

■ Dimensions by Stroke

X: Nominal stroke	50	100	150	200	250	300	350	400	450	500	550	600	650	700	750	800	850	900	950	1000
B	50	100	150	200	250	300	350	400	450	500	550	600	650	700	750	800	850	900	950	1000
C	50	100	150	0	50	100	150	0	50	100	150	0	50	100	150	0	50	100	150	0
D	8	8	8	10	12	12	12	14	16	16	16	18	20	20	20	22	24	24	24	26
N	1	1	1	2	2	2	2	3	3	3	3	4	4	4	4	5	5	5	5	6
G	114.5	139.5	164.5	189.5	214.5	239.5	264.5	289.5	314.5	339.5	364.5	389.5	414.5	439.5	464.5	489.5	514.5	539.5	564.5	589.5

Controllers

Applicable controller



Refer to P. 91 for the controllers.

IK2-SXBB1□□D

RCS2 2-axis Combinations X axis: SS8R (100W, Reversed, Double-slider)
Y axis: SA7R (Reversed)

Model Details

Series: IK2 — Type: SXBB1□□D — Encoder type: □ — Axis 1 (X axis): □ — Axis 2 (Y axis): □ — Controller: □ — Cable: □ — Shipping configuration: □

Combination directions 1-2

Differences between Single-slider and Double-slider Types
 HH: X high-speed, Y high-speed
 MM: X medium-speed, Y medium-speed

Encoder type
 I: Incremental
 A: Absolute

Stroke (mm)
 S: 50mm
 (Can be set in 50-mm increments)

Options
 NM: Opposite-home specification
 SR: Slider roller specification

Controllers
 T1: XSEL-J/K
 T2: SSEL
 XSEL-P/Q

Cable length
 1L: 1m
 3L: 3m
 5L: 5m
 □L: □m

Wiring 1
 N: Cable only
 CT: With cable track

Wiring 2

Shipping configuration
 K: Individual components (kit)

* Refer to P.10 for details on the items comprising the model name.

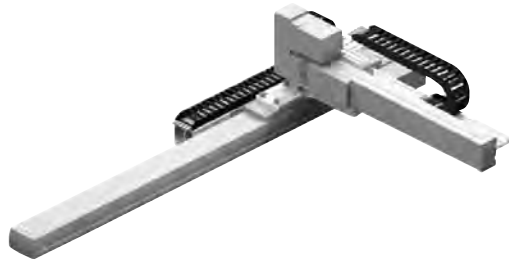

Both wiring 1 and wiring 2 assume use of a cable track.

Maximum Stroke

X axis 800 mm Y axis 400 mm

Maximum Speed

	High-speed type	Medium-speed type
X axis	1000mm/s	500mm/s
Y axis	800mm/s	400mm/s

Maximum Load Capacity

Y-axis stroke	X high-speed, Y high-speed	X medium-speed, Y medium-speed
200mm	—	15kg
250mm	—	12.5kg
300mm	—	12.5kg
350mm	6.0kg	12kg
400mm	5.5kg	10.5kg

List by Stroke

Y-axis stroke	Incremental					Absolute				
	200	250	300	350	400	200	250	300	350	400
50	—	—	—	—	—	—	—	—	—	—
100	—	—	—	—	—	—	—	—	—	—
150	—	—	—	—	—	—	—	—	—	—
200	—	—	—	—	—	—	—	—	—	—
250	—	—	—	—	—	—	—	—	—	—
300	—	—	—	—	—	—	—	—	—	—
350	—	—	—	—	—	—	—	—	—	—
400	—	—	—	—	—	—	—	—	—	—
450	—	—	—	—	—	—	—	—	—	—
500	—	—	—	—	—	—	—	—	—	—
550	—	—	—	—	—	—	—	—	—	—
600	—	—	—	—	—	—	—	—	—	—
650	—	—	—	—	—	—	—	—	—	—
700	—	—	—	—	—	—	—	—	—	—
750	—	—	—	—	—	—	—	—	—	—
800	—	—	—	—	—	—	—	—	—	—

Note: For the X high-speed/Y high-speed type, the Y-axis stroke must be 350 mm or more.

List by Cable Length

Type	Cable code	Length
Standard type	1L	1m
	3L	3m
	5L	5m

* Axis 1 comes with a standard cable, while axis 2 comes with a robot cable.

* Refer to P.90 for lengths other than those specified above.

Cable track

Wiring 1 (Next to X-axis)	X-axis stroke	50-300	350-600	650-800
Wiring 2 (Next to Y-axis)	Y-axis stroke	200	250-400	—

List of Options

Name	Option code	
Opposite-home specification	NM	
Slider roller specification	SR	Axis 1 (X-axis) Axis 2 (Y-axis)

Specifications

Item	X axis	Y axis
Axis model	RCS2-SS8R	RCS2-SA7R
Stroke (Can be set in 50-mm increments)	50-800mm	High-speed type: 350-400mm Medium-speed type: 200-400mm
Max speed	Stroke High speed Medium speed	200-400mm 800mm/s 400mm/s
Motor output (W)	100W	60W
Ball screw lead	High-speed type: 20mm Medium-speed type: 10mm	High-speed type: 16mm Medium-speed type: 8mm
Drive method	Ball screw, ø16 mm, rolled, C10	Ball screw, ø12 mm, rolled, C10
Positioning repeatability	±0.02mm	
Base material	Dedicated alloy steel	Aluminum
Surrounding air temperature/humidity	0 to 40°C, 85% RH or below (non-condensing)	

Dimensions

You can download CAD drawings from our website. www.intelligentactuator.com

Note 1. The connected position shown in the drawing defines the home.
 Note 2. Both wiring 1 and wiring 2 assume use of a cable track.
 Note 3. For details on the cable track, refer to P. 90.
 Note 4. For details on the bracket on the moving end of the cable track, refer to P. 90.

* Caution

Customer to prepare the parts and attach the X-axis cable track guide rail to the same plane the X-axis actuator is installed. Also customer to prepare the parts and attach the Y-axis cable track free end (Y-axis slider side) to the customer's bracket on the Y-axis slider.

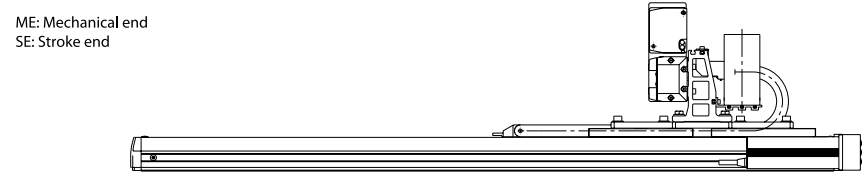
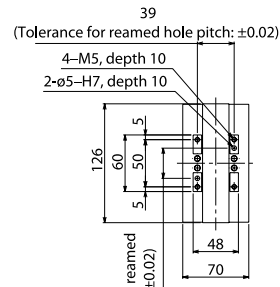
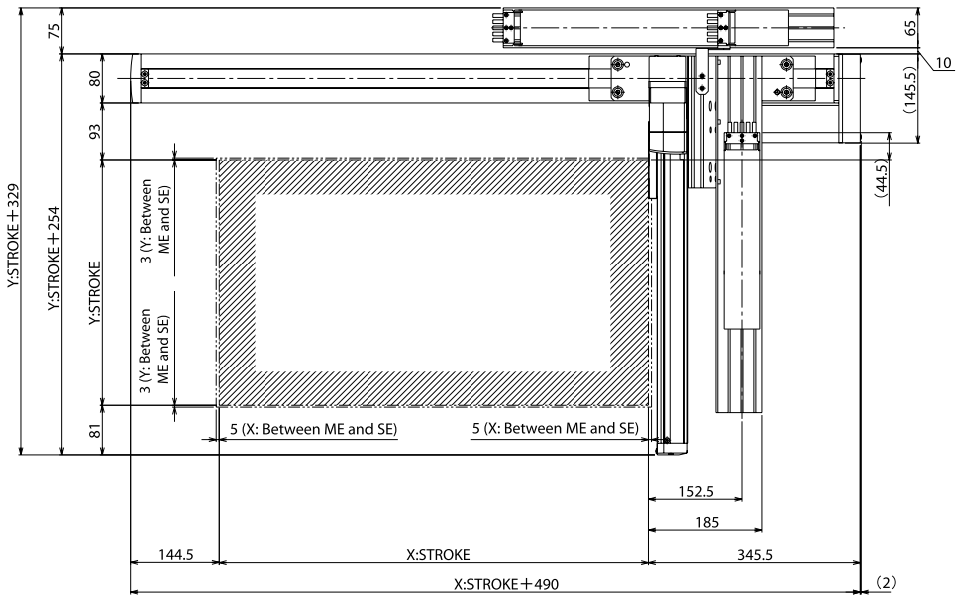
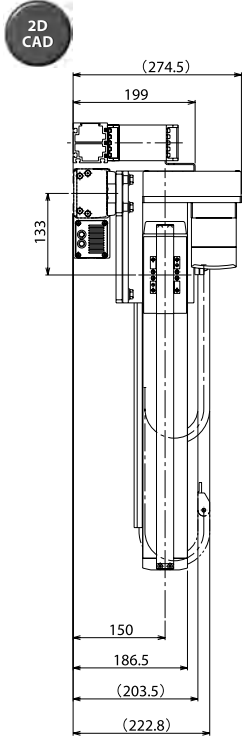

Detail view of Y-axis slider



Detail view of slot in bottom face of X-axis base

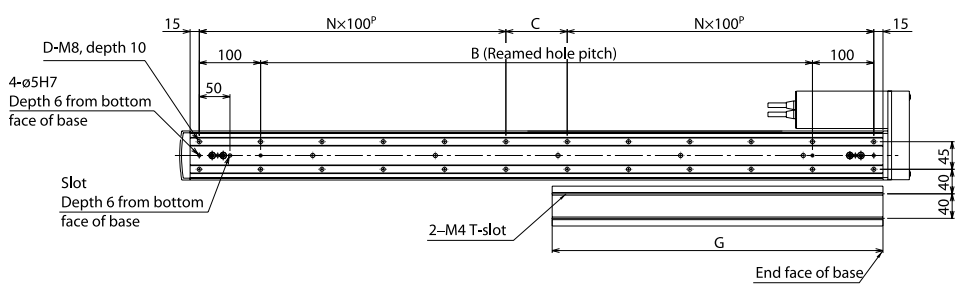

Detail view of X-axis installation

■ Dimensions by Stroke

X: Nominal stroke	250	300	350	400	450	500	550	600	650	700	750	800	850	900	950	1000
X: Effective stroke	50	100	150	200	250	300	350	400	450	500	550	600	650	700	750	800
B	250	300	350	400	450	500	550	600	650	700	750	800	850	900	950	1000
C	50	100	150	0	50	100	150	0	50	100	150	0	50	100	150	0
D	12	12	12	14	16	16	16	18	20	20	20	22	24	24	24	26
N	2	2	2	3	3	3	3	4	4	4	4	5	5	5	5	6
G	214.5	239.5	264.5	289.5	314.5	339.5	364.5	389.5	414.5	439.5	464.5	489.5	514.5	539.5	564.5	589.5

Controllers

Applicable controller

☞ Refer to P. 91 for the controllers.

IK2-SXBB2□□S

RCS2 2-axis Combinations X axis: SS8C (100W, Straight, Single-slider)
Y axis: SA7R (Reversed)

2-axis Combinations RCP2
2-axis Combinations RCS2
3-axis Combinations RCP2
3-axis Combinations RCS2
Controllers

Model Details

Series: **IK2** — Type: **SXBB2**□□S — Encoder type: — Axis 1 (X axis): — Axis 2 (Y axis): — Controller: — Cable: — Shipping configuration:

IK2 — **SXBB2**□□S

Combination directions: 1-4

Differences between Single-slider and Double-slider Types:
HH: X high-speed, Y high-speed
MM: X medium-speed, Y medium-speed

Encoder type:
I: Incremental
A: Absolute

Stroke (mm): 5-50mm
(Can be set in 50-mm increments)

Options:
NM: Opposite-home specification
SR: Slider roller specification

Controllers:
T1: XSEL-J/K
T2: SSEL
XSEL-P/Q

Cable length:
1L: 1m
3L: 3m
5L: 5m
L: m

Wiring 1: Cable only
CT: With cable track

Wiring 2:

Shipping configuration:
K: Individual components (kit)

* Refer to P.10 for details on the items comprising the model name.

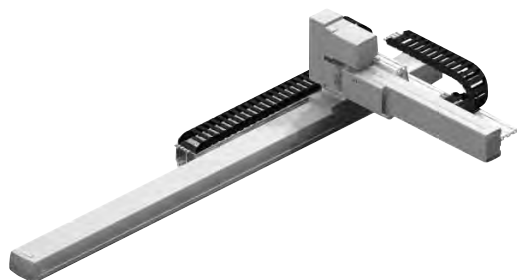

Both wiring 1 and wiring 2 assume use of a cable track.

Maximum Stroke

X axis 1000 mm **Y axis** 300 mm

Maximum Speed

	High-speed type	Medium-speed type
X axis	1000mm/s	500mm/s
Y axis	800mm/s	400mm/s

Maximum Load Capacity

Y-axis stroke	X high-speed, Y high-speed	X medium-speed, Y medium-speed
50mm	8.0kg	16kg
100mm	8.0kg	16kg
150mm	7.0kg	15kg
200mm	7.0kg	12.5kg
250mm	6.0kg	9.0kg
300mm	6.0kg	8.0kg

List by Stroke

Y-axis stroke	Incremental						Absolute					
	50	100	150	200	250	300	50	100	150	200	250	300
50	-	-	-	-	-	-	-	-	-	-	-	-
100	-	-	-	-	-	-	-	-	-	-	-	-
150	-	-	-	-	-	-	-	-	-	-	-	-
200	-	-	-	-	-	-	-	-	-	-	-	-
250	-	-	-	-	-	-	-	-	-	-	-	-
300	-	-	-	-	-	-	-	-	-	-	-	-
350	-	-	-	-	-	-	-	-	-	-	-	-
400	-	-	-	-	-	-	-	-	-	-	-	-
450	-	-	-	-	-	-	-	-	-	-	-	-
500	-	-	-	-	-	-	-	-	-	-	-	-
550	-	-	-	-	-	-	-	-	-	-	-	-
600	-	-	-	-	-	-	-	-	-	-	-	-
650	-	-	-	-	-	-	-	-	-	-	-	-
700	-	-	-	-	-	-	-	-	-	-	-	-
750	-	-	-	-	-	-	-	-	-	-	-	-
800	-	-	-	-	-	-	-	-	-	-	-	-
850	-	-	-	-	-	-	-	-	-	-	-	-
900	-	-	-	-	-	-	-	-	-	-	-	-
950	-	-	-	-	-	-	-	-	-	-	-	-
1000	-	-	-	-	-	-	-	-	-	-	-	-

List by Cable Length

Type	Cable code	Length
Standard type	1L	1m
	3L	3m
	5L	5m

* Axis 1 comes with a standard cable, while axis 2 comes with a robot cable.
* Refer to P.90 for lengths other than those specified above.

Cable track

Wiring 1 (Next to X-axis)	X-axis stroke	50-300	350-600	650-900	950-1000
Wiring 2 (Next to Y-axis)	Y-axis stroke	50-200	250-300	-	-

List of Options

Name	Option code	
Opposite-home specification	NM	
Slider roller specification	SR	Axis 1 (X-axis) Axis 2 (Y-axis)

Specifications

Item	X axis						Y axis
Axis model	RCS2-SS8C						RCS2-SA7R
Stroke (Can be set in 50-mm increments)	50-1000mm						50-300mm
Max speed	Stroke	50-600mm	650-700mm	750-800mm	850-900mm	950-1000mm	50-300mm
	High speed	1000mm/s	960mm/s	765mm/s	625mm/s	515mm/s	800mm/s
	Medium speed	500mm/s	480mm/s	380mm/s	310mm/s	255mm/s	400mm/s
Motor output (W)	100W						60W
Ball screw lead	High-speed type: 20mm Medium-speed type: 10mm						High-speed type: 16mm Medium-speed type: 8mm
Drive method	Ball screw, ø16 mm, rolled, C10						Ball screw, ø12 mm, rolled, C10
Positioning repeatability	±0.02mm						
Base material	Dedicated alloy steel						Aluminum
Surrounding air temperature/humidity	0 to 40°C, 85% RH or below (non-condensing)						

Dimensions

You can download CAD drawings from our website.

www.intelligentactuator.com

- Note 1. The connected position shown in the drawing defines the home.
- Note 2. Both wiring 1 and wiring 2 assume use of a cable track.
- Note 3. For details on the cable track, refer to P. 90.
- Note 4. For details on the bracket on the moving end of the cable track, refer to P. 90.

* Caution

Customer to prepare the parts and attach the X-axis cable track guide rail to the same plane the X-axis actuator is installed. Also customer to prepare the parts and attach the Y-axis cable track free end (Y-axis slider side) to the customer's bracket on the Y-axis slider.

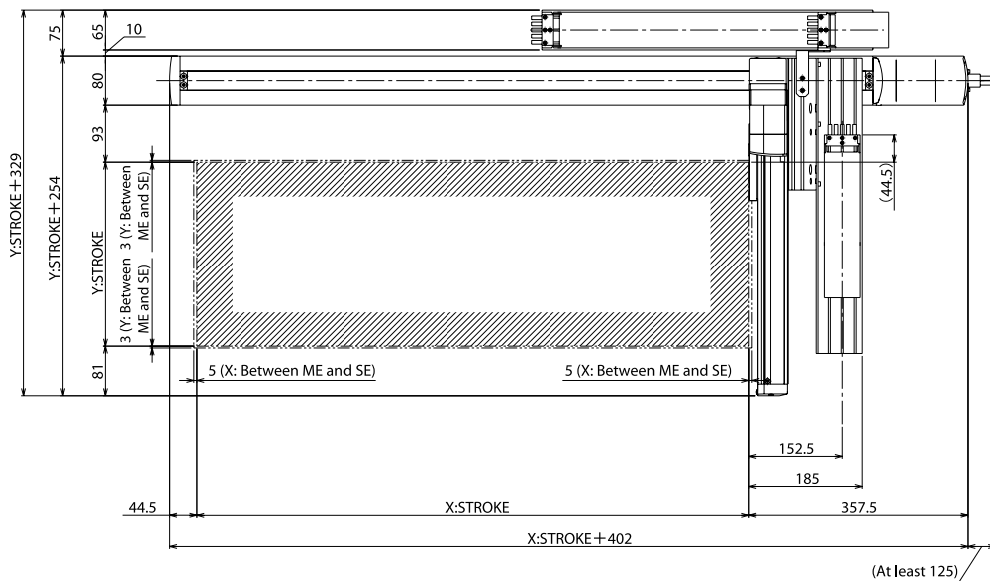
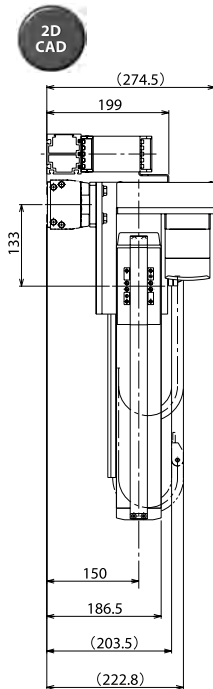

39
(Tolerance for reamed hole pitch: ±0.02)

- 4-M5, depth 10
- 2-ø5-H7, depth 10

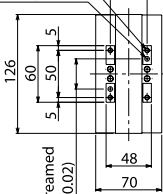

32
(Tolerance for reamed hole pitch: ±0.02)

ME: Mechanical end
SE: Stroke end

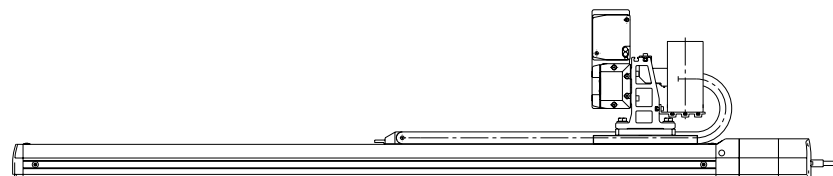

Detail view of Y-axis slider

- 4-ø5H7
Depth 6 from bottom face of base



Detail view of slot in bottom face of X-axis base

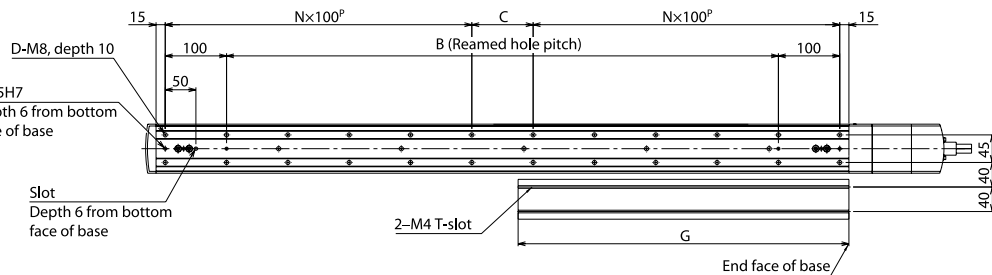

Detail view of X-axis installation

■ Dimensions by Stroke

X: Nominal stroke	50	100	150	200	250	300	350	400	450	500	550	600	650	700	750	800	850	900	950	1000	
B	50	100	150	200	250	300	350	400	450	500	550	600	650	700	750	800	850	900	950	1000	
C	50	100	150	0	50	100	150	0	50	100	150	0	50	100	150	0	50	100	150	0	
D	8	8	8	10	12	12	12	14	16	16	16	18	20	20	20	22	24	24	24	26	26
N	1	1	1	2	2	2	2	3	3	3	3	4	4	4	4	5	5	5	5	5	6
G	114.5	139.5	164.5	189.5	214.5	239.5	264.5	289.5	314.5	339.5	364.5	389.5	414.5	439.5	464.5	489.5	514.5	539.5	564.5	589.5	

Controllers

Applicable controller



Refer to P. 91 for the controllers.

IK2-SXBB2□□D

RCS2 2-axis Combinations X axis: SS8C (100W, Straight, Double-slider)
Y axis: SA7R (Reversed)

Model Details

Series: **IK2** Type: **SXBB2** Encoder type: **D**

Axis 1 (X axis): Stroke (mm) 5: 50mm, Options: NM: Opposite-home specification, SR: Slider roller specification

Axis 2 (Y axis): Stroke (mm) 5: 50mm, Options: NM: Opposite-home specification, SR: Slider roller specification

Controllres: []

Cable length: 1L: 1m, 3L: 3m, 5L: 5m

Wiring 1: N: Cable only, CT: With cable track

Wiring 2: []

Shipping configuration: K: Individual components (kit)

* Refer to P.10 for details on the items comprising the model name.

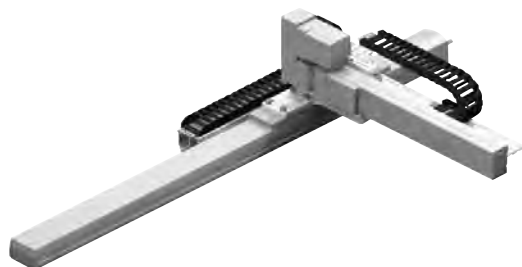

Both wiring 1 and wiring 2 assume use of a cable track.

Maximum Stroke

X axis **800 mm** Y axis **400 mm**

Maximum Speed

	High-speed type	Medium-speed type
X axis	1000mm/s	500mm/s
Y axis	800mm/s	400mm/s

Maximum Load Capacity

Y-axis stroke	X high-speed, Y high-speed	X medium-speed, Y medium-speed
200mm	—	15kg
250mm	—	12.5kg
300mm	—	12.5kg
350mm	6.0kg	12kg
400mm	5.5kg	10.5kg

List by Stroke

Y-axis stroke	Incremental					Absolute				
	200	250	300	350	400	200	250	300	350	400
50	—	—	—	—	—	—	—	—	—	—
100	—	—	—	—	—	—	—	—	—	—
150	—	—	—	—	—	—	—	—	—	—
200	—	—	—	—	—	—	—	—	—	—
250	—	—	—	—	—	—	—	—	—	—
300	—	—	—	—	—	—	—	—	—	—
350	—	—	—	—	—	—	—	—	—	—
400	—	—	—	—	—	—	—	—	—	—
450	—	—	—	—	—	—	—	—	—	—
500	—	—	—	—	—	—	—	—	—	—
550	—	—	—	—	—	—	—	—	—	—
600	—	—	—	—	—	—	—	—	—	—
650	—	—	—	—	—	—	—	—	—	—
700	—	—	—	—	—	—	—	—	—	—
750	—	—	—	—	—	—	—	—	—	—
800	—	—	—	—	—	—	—	—	—	—

Note: For the X high-speed/Y high-speed type, the Y-axis stroke must be 350 mm or more.

List by Cable Length

Type	Cable code	Length
Standard type	1L	1m
	3L	3m
	5L	5m

* Axis 1 comes with a standard cable, while axis 2 comes with a robot cable.

* Refer to P.90 for lengths other than those specified above.

Cable track

Wiring 1 (Next to X-axis)	X-axis stroke	50-300	350-600	650-800
Wiring 2 (Next to Y-axis)	Y-axis stroke	200	250-400	—

List of Options

Name	Option code	
Opposite-home specification	NM	
Slider roller specification	SR	Axis 1 (X-axis) Axis 2 (Y-axis)

Specifications

Item	X axis	Y axis
Axis model	RCS2-SS8C	RCS2-SA7R
Stroke (Can be set in 50-mm increments)	50-800mm	High-speed type: 350-400mm Medium-speed type: 200-400mm
Max speed	Stroke	200-400mm
	High speed	800mm/s
Motor output (W)	Medium speed	400mm/s
	50-400mm	60W
Ball screw lead	450-500mm	High-speed type: 16mm
	550-600mm	Medium-speed type: 8mm
Drive method	650-700mm	Ball screw, ø12 mm, rolled, C10
	750-800mm	Ball screw, ø16 mm, rolled, C10
Positioning repeatability	±0.02mm	
Base material	Dedicated alloy steel	Aluminum
Surrounding air temperature/humidity	0 to 40°C, 85% RH or below (non-condensing)	

Dimensions

You can download CAD drawings from our website.

www.intelligentactuator.com

- Note 1. The connected position shown in the drawing defines the home.
- Note 2. Both wiring 1 and wiring 2 assume use of a cable track.
- Note 3. For details on the cable track, refer to P.90.
- Note 4. For details on the bracket on the moving end of the cable track, refer to P.90.

* Caution

Customer to prepare the parts and attach the X-axis cable track guide rail to the same plane the X-axis actuator is installed. Also customer to prepare the parts and attach the Y-axis cable track free end (Y-axis slider side) to the customer's bracket on the Y-axis slider.

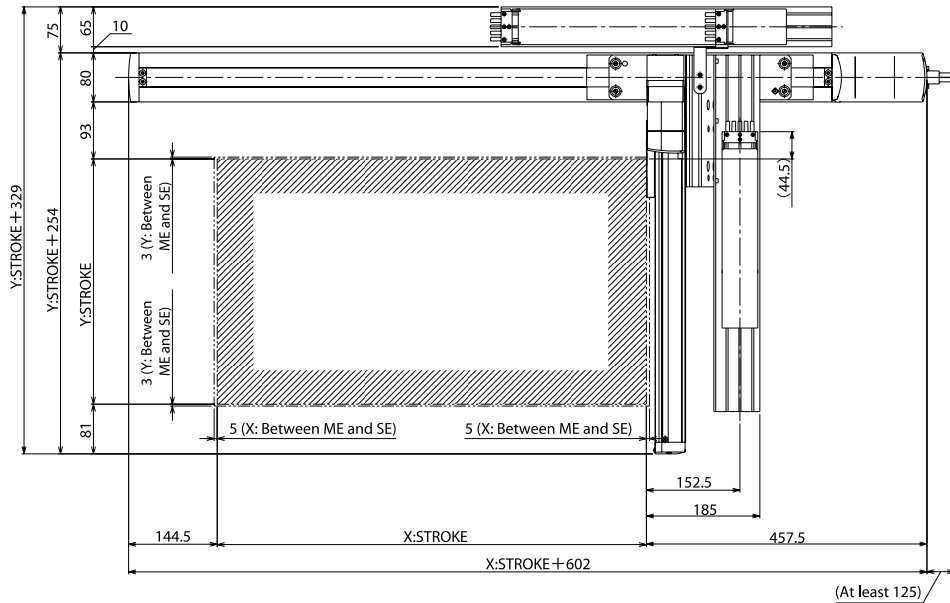
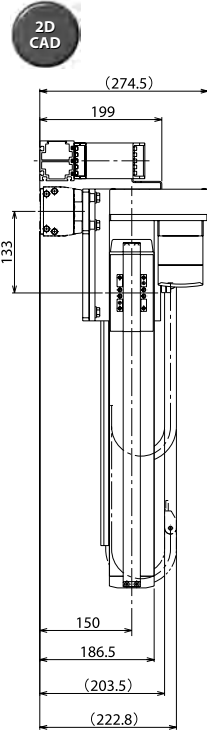

ME: Mechanical end
SE: Stroke end

39
(Tolerance for reamed hole pitch: ±0.02)

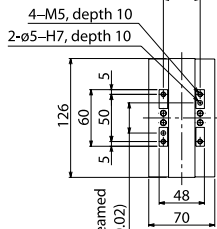

Detail view of Y-axis slider



Detail view of slot in bottom face of X-axis base

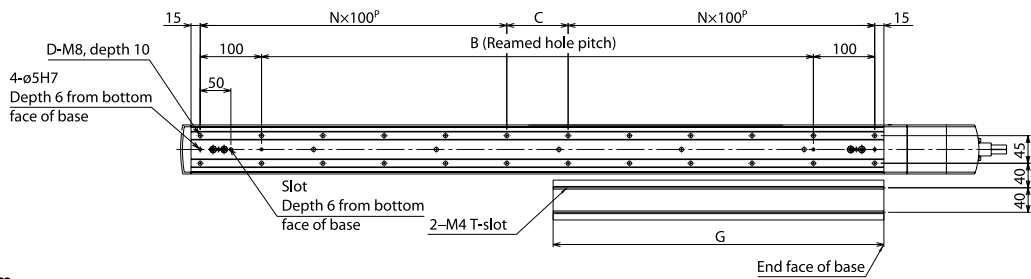
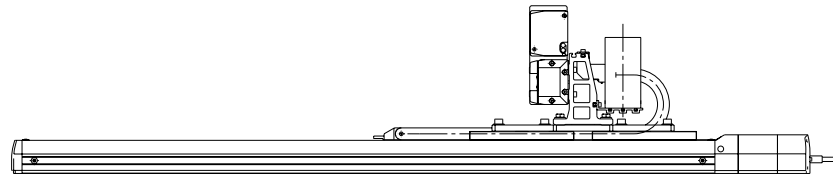

Detail view of X-axis installation

■ Dimensions by Stroke

X: Nominal stroke	250	300	350	400	450	500	550	600	650	700	750	800	850	900	950	1000
X: Effective stroke	50	100	150	200	250	300	350	400	450	500	550	600	650	700	750	800
B	250	300	350	400	450	500	550	600	650	700	750	800	850	900	950	1000
C	50	100	150	0	50	100	150	0	50	100	150	0	50	100	150	0
D	12	12	12	14	16	16	16	18	20	20	20	22	24	24	24	26
N	2	2	2	3	3	3	3	4	4	4	4	5	5	5	5	6
G	214.5	239.5	264.5	289.5	314.5	339.5	364.5	389.5	414.5	439.5	464.5	489.5	514.5	539.5	564.5	589.5

Controllers

Applicable controller



Refer to P. 91 for the controllers.

IK2-SXBA1□□S

RCS2 2-axis Combinations X axis: SS8R (150W, Reversed, Single-slider)
Y axis: SS8R (100W, Reversed)

Model Details

Series: **IK2** | Type: **SXBA1□□S** | Encoder type: | Axis 1 (X axis): | Axis 2 (Y axis): | Controllres: | Cable: | Shipping configuration:

Combination directions T-Z

Differences between Single-slider and Double-slider Types
 HH: X high-speed, Y high-speed
 MM: X medium-speed, Y medium-speed

Encoder type
 I: Incremental
 A: Absolute

Stroke (mm)
 5: 50mm
 (Can be set in 50-mm increments)

Options
 NM: Opposite-home specification
 SR: Slider roller specification

Controllers
 T1: XSEL-J/K
 T2: SSEL
 XSEL-P/Q

Cable length
 1L: 1m
 3L: 3m
 5L: 5m
 L: m

Wiring 1
 N: Cable only
 CT: With cable track

Wiring 2

Shipping configuration
 K: Individual components (kit)

* Refer to P.10 for details on the items comprising the model name.



Both wiring 1 and wiring 2 assume use of a cable track.

Maximum Stroke

X axis 1000 mm | **Y axis** 350 mm

Maximum Speed

	High-speed type	Medium-speed type
X axis	1000mm/s	500mm/s
Y axis	1000mm/s	500mm/s

Maximum Load Capacity

Y-axis stroke	X high-speed, Y high-speed	X medium-speed, Y medium-speed
50mm	12kg	24kg
100mm	12kg	20.5kg
150mm	11.5kg	15.5kg
200mm	11kg	12.5kg
250mm	10kg	–
300mm	8.5kg	–
350mm	7kg	–

List by Stroke

Y-axis stroke	Incremental							Absolute						
	50	100	150	200	250	300	350	50	100	150	200	250	300	350
50	-	-	-	-	-	-	-	-	-	-	-	-	-	-
100	-	-	-	-	-	-	-	-	-	-	-	-	-	-
150	-	-	-	-	-	-	-	-	-	-	-	-	-	-
200	-	-	-	-	-	-	-	-	-	-	-	-	-	-
250	-	-	-	-	-	-	-	-	-	-	-	-	-	-
300	-	-	-	-	-	-	-	-	-	-	-	-	-	-
350	-	-	-	-	-	-	-	-	-	-	-	-	-	-
400	-	-	-	-	-	-	-	-	-	-	-	-	-	-
450	-	-	-	-	-	-	-	-	-	-	-	-	-	-
500	-	-	-	-	-	-	-	-	-	-	-	-	-	-
550	-	-	-	-	-	-	-	-	-	-	-	-	-	-
600	-	-	-	-	-	-	-	-	-	-	-	-	-	-
650	-	-	-	-	-	-	-	-	-	-	-	-	-	-
700	-	-	-	-	-	-	-	-	-	-	-	-	-	-
750	-	-	-	-	-	-	-	-	-	-	-	-	-	-
800	-	-	-	-	-	-	-	-	-	-	-	-	-	-
850	-	-	-	-	-	-	-	-	-	-	-	-	-	-
900	-	-	-	-	-	-	-	-	-	-	-	-	-	-
950	-	-	-	-	-	-	-	-	-	-	-	-	-	-
1000	-	-	-	-	-	-	-	-	-	-	-	-	-	-

Note: For the X medium-speed/Y medium-speed type, the Y-axis stroke must be 200 mm or less.

List by Cable Length

Type	Cable code	Length
Standard type	1L	1m
	3L	3m
	5L	5m

* Axis 1 comes with a standard cable, while axis 2 comes with a robot cable.
 * Refer to P.90 for lengths other than those specified above.

Cable track

Wiring 1 (Next to X-axis)	X-axis stroke	50-300	350-600	650-900	950-1000
Wiring 2 (Next to Y-axis)	Y-axis stroke	50-200	250-300	–	–

List of Options

Name	Option code	
Opposite-home specification	NM	
Slider roller specification	SR	Axis 1 (X-axis) Axis 2 (Y-axis)

Specifications

Item	X axis	Y axis
Axis model	RCS2-SS8R	RCS2-SS8R
Stroke (Can be set in 50-mm increments)	50-1000mm	High-speed type: 50-350mm Medium-speed type: 50-200mm
Max speed	Stroke	50-600mm
	High speed	650-700mm
Motor output (W)	Medium speed	750-800mm
	High speed	850-900mm
Ball screw lead	Medium speed	950-1000mm
	High speed	1000mm/s
Drive method	Medium speed	960mm/s
	High speed	480mm/s
Positioning repeatability	Medium speed	765mm/s
	High speed	380mm/s
Base material	Medium speed	625mm/s
	High speed	310mm/s
Surrounding air temperature/humidity	Medium speed	515mm/s
	High speed	255mm/s
Motor output (W)	150W	100W
Ball screw lead	High-speed type: 20mm Medium-speed type: 10mm	
Drive method	Ball screw, ø16 mm, rolled, C10	
Positioning repeatability	±0.02mm	
Base material	Dedicated alloy steel	
Surrounding air temperature/humidity	0 to 40°C, 85% RH or below (non-condensing)	

Dimensions

You can download CAD drawings from our website.

www.intelligentactuator.com

- Note 1. The connected position shown in the drawing defines the home.
- Note 2. Both wiring 1 and wiring 2 assume use of a cable track.
- Note 3. For details on the cable track, refer to P. 90.
- Note 4. For details on the bracket on the moving end of the cable track, refer to P. 90.

* Caution

Customer to prepare the parts and attach the X-axis cable track guide rail to the same plane the X-axis actuator is installed. Also customer to prepare the parts and attach the Y-axis cable track free end (Y-axis slider side) to the customer's bracket on the Y-axis slider.

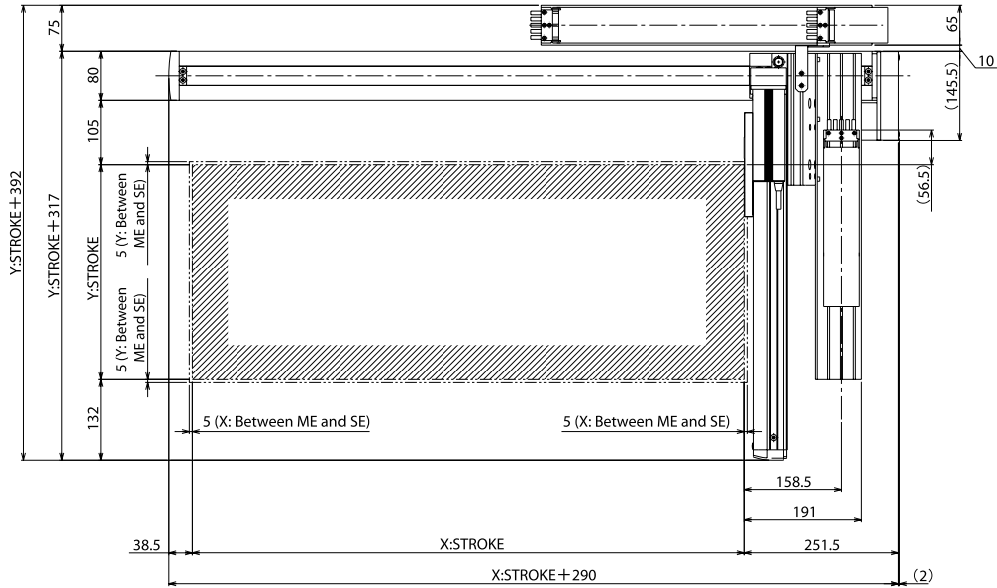
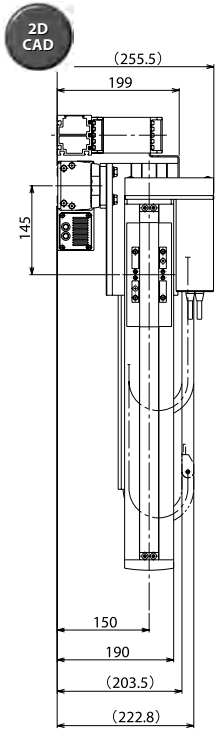

ME: Mechanical end
SE: Stroke end

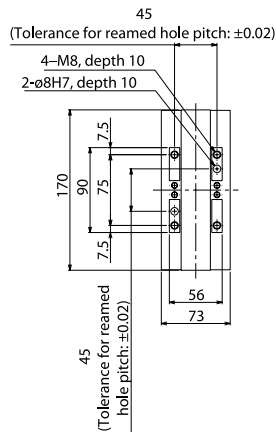

Detail view of Y-axis slider



Detail view of slot in bottom face of X-axis base

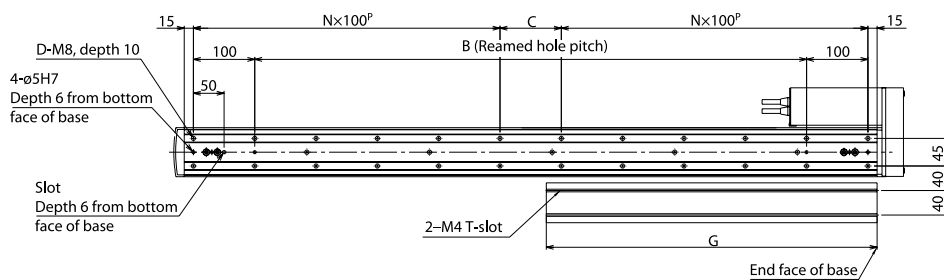
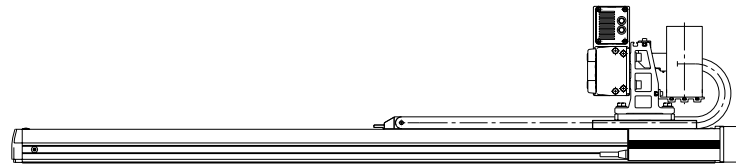

Detail view of X-axis installation

■ Dimensions by Stroke

X: Nominal stroke	50	100	150	200	250	300	350	400	450	500	550	600	650	700	750	800	850	900	950	1000
B	50	100	150	200	250	300	350	400	450	500	550	600	650	700	750	800	850	900	950	1000
C	50	100	150	0	50	100	150	0	50	100	150	0	50	100	150	0	50	100	150	0
D	8	8	8	10	12	12	12	14	16	16	16	18	20	20	20	22	24	24	24	26
N	1	1	1	2	2	2	2	3	3	3	3	4	4	4	4	5	5	5	5	6
G	114.5	139.5	164.5	189.5	214.5	239.5	264.5	289.5	314.5	339.5	364.5	389.5	414.5	439.5	464.5	489.5	514.5	539.5	564.5	589.5

Controllers

Applicable controller



Refer to P. 91 for the controllers.

IK2-SXBA1□□D

RCS2 2-axis Combinations X axis: SS8R (150W, Reversed, Double-slider)
Y axis: SS8R (100W, Reversed)

2-axis Combinations RCP2
2-axis Combinations RCS2
3-axis Combinations RCP2
3-axis Combinations RCS2
Controllers

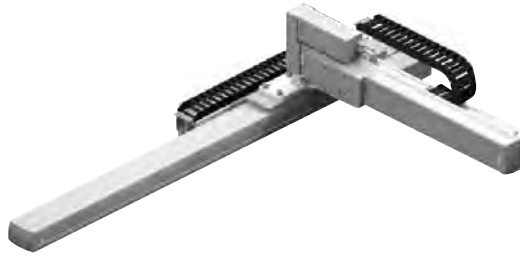
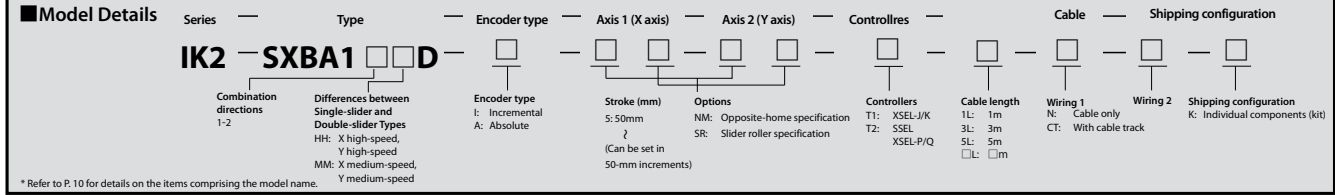

Both wiring 1 and wiring 2 assume use of a cable track.

Maximum Stroke

X axis 800 mm Y axis 400 mm

Maximum Speed

	High-speed type	Medium-speed type
X axis	1000mm/s	500mm/s
Y axis	1000mm/s	500mm/s

Maximum Load Capacity

Y-axis stroke	X high-speed, Y high-speed	X medium-speed, Y medium-speed
100mm	—	24kg
150mm	—	24kg
200mm	—	23kg
250mm	—	19kg
300mm	11kg	16kg
350mm	10.5kg	13.5kg
400mm	10kg	11.5kg

List by Stroke

Y-axis stroke	Incremental								Absolute							
	100	150	200	250	300	350	400	100	150	200	250	300	350	400		
50	-	-	-	-	-	-	-	-	-	-	-	-	-	-		
100	-	-	-	-	-	-	-	-	-	-	-	-	-	-		
150	-	-	-	-	-	-	-	-	-	-	-	-	-	-		
200	-	-	-	-	-	-	-	-	-	-	-	-	-	-		
250	-	-	-	-	-	-	-	-	-	-	-	-	-	-		
300	-	-	-	-	-	-	-	-	-	-	-	-	-	-		
350	-	-	-	-	-	-	-	-	-	-	-	-	-	-		
400	-	-	-	-	-	-	-	-	-	-	-	-	-	-		
450	-	-	-	-	-	-	-	-	-	-	-	-	-	-		
500	-	-	-	-	-	-	-	-	-	-	-	-	-	-		
550	-	-	-	-	-	-	-	-	-	-	-	-	-	-		
600	-	-	-	-	-	-	-	-	-	-	-	-	-	-		
650	-	-	-	-	-	-	-	-	-	-	-	-	-	-		
700	-	-	-	-	-	-	-	-	-	-	-	-	-	-		
750	-	-	-	-	-	-	-	-	-	-	-	-	-	-		
800	-	-	-	-	-	-	-	-	-	-	-	-	-	-		

Note: For the X high-speed/Y high-speed type, the Y-axis stroke must be 300 mm or more.

List by Cable Length

Type	Cable code	Length
Standard type	1L	1m
	3L	3m
	5L	5m

* Axis 1 comes with a standard cable, while axis 2 comes with a robot cable.
* Refer to P.90 for lengths other than those specified above.

Cable track

Wiring	X-axis stroke	50-300	350-600	650-800
Wiring 1 (Next to X-axis)	Y-axis stroke			
Wiring 2 (Next to Y-axis)	Y-axis stroke	200	250-400	—

List of Options

Name	Option code	
Opposite-home specification	NM	
Slider roller specification	SR	Axis 1 (X-axis) Axis 2 (Y-axis)

Specifications

Item	X axis	Y axis
Axis model	RCS2-SS8R	RCS2-SS8R
Stroke (Can be set in 50-mm increments)	50-800mm	High-speed type: 300-400mm Medium speed type: 100-400mm
Max speed	Stroke High speed Medium speed	100-400mm 1000mm/s 500mm/s
Motor output (W)	150W	100W
Ball screw lead	High-speed type: 20mm Medium-speed type: 10mm	
Drive method	Ball screw, ø16 mm, rolled, C10	
Positioning repeatability	±0.02mm	
Base material	Dedicated alloy steel	
Surrounding air temperature/humidity	0 to 40°C, 85% RH or below (non-condensing)	

Dimensions

You can download CAD drawings from our website. www.intelligentactuator.com

- Note 1. The connected position shown in the drawing defines the home.
- Note 2. Both wiring 1 and wiring 2 assume use of a cable track.
- Note 3. For details on the cable track, refer to P.90.
- Note 4. For details on the bracket on the moving end of the cable track, refer to P.90.

* Caution

Customer to prepare the parts and attach the X-axis cable track guide rail to the same plane the X-axis actuator is installed. Also customer to prepare the parts and attach the Y-axis cable track free end (Y-axis slider side) to the customer's bracket on the Y-axis slider.

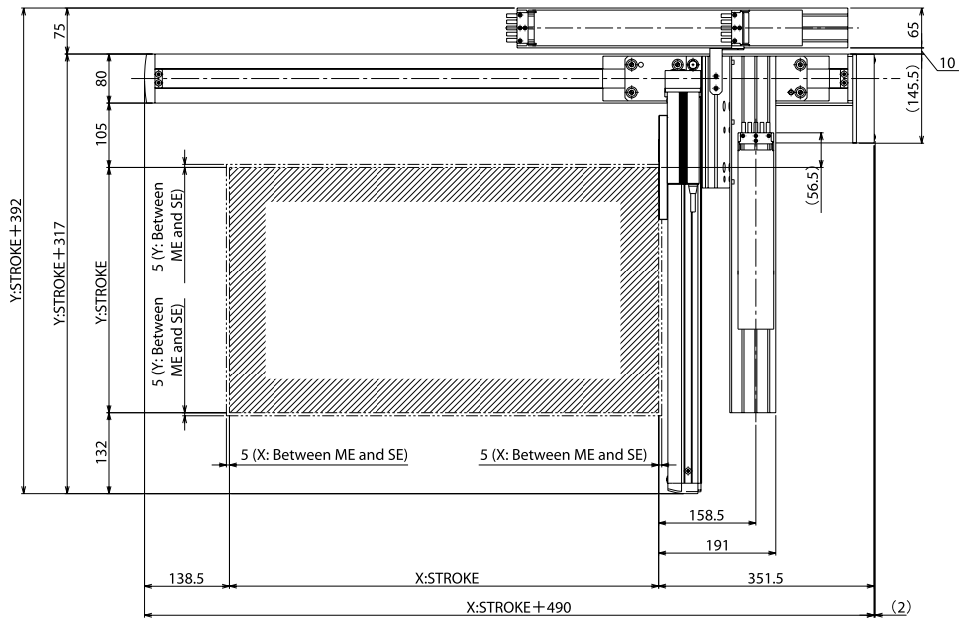
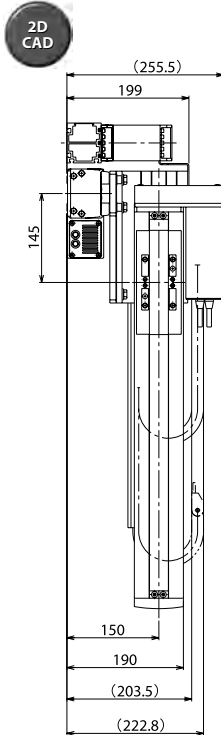

ME: Mechanical end
SE: Stroke end

45
(Tolerance for reamed hole pitch: ±0.02)

4-M8, depth 10
2-ø8H7, depth 10

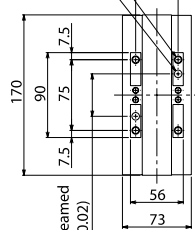

45
(Tolerance for reamed hole pitch: ±0.02)

Detail view of Y-axis slider



Detail view of slot in bottom face of X-axis base

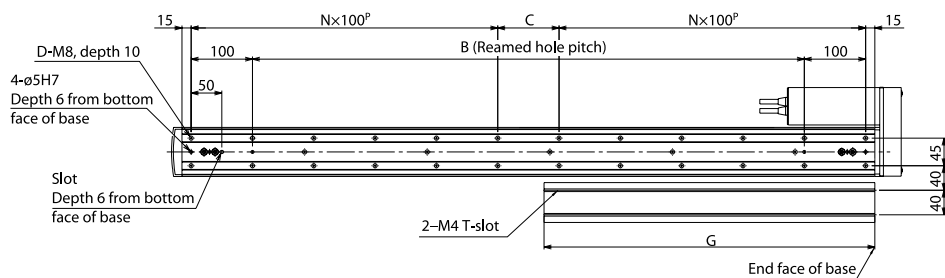
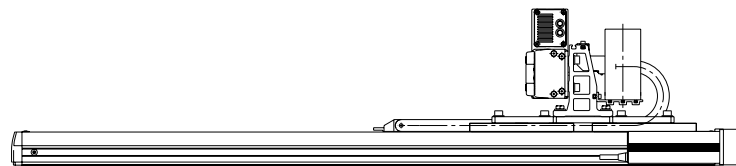

Detail view of X-axis installation

■ Dimensions by Stroke

X: Nominal stroke	250	300	350	400	450	500	550	600	650	700	750	800	850	900	950	1000
X: Effective stroke	50	100	150	200	250	300	350	400	450	500	550	600	650	700	750	800
B	250	300	350	400	450	500	550	600	650	700	750	800	850	900	950	1000
C	50	100	150	0	50	100	150	0	50	100	150	0	50	100	150	0
D	12	12	12	14	16	16	16	18	20	20	20	22	24	24	24	26
N	2	2	2	3	3	3	3	4	4	4	4	5	5	5	5	6
G	214.5	239.5	264.5	289.5	314.5	339.5	364.5	389.5	414.5	439.5	464.5	489.5	514.5	539.5	564.5	589.5

Controllers

Applicable controller



Refer to P. 91 for the controllers.

IK2-SXBA2□□S

RCS2 2-axis Combinations X axis: SS8C (150W, Straight, Single-slider)
Y axis: SS8R (100W, Reversed)

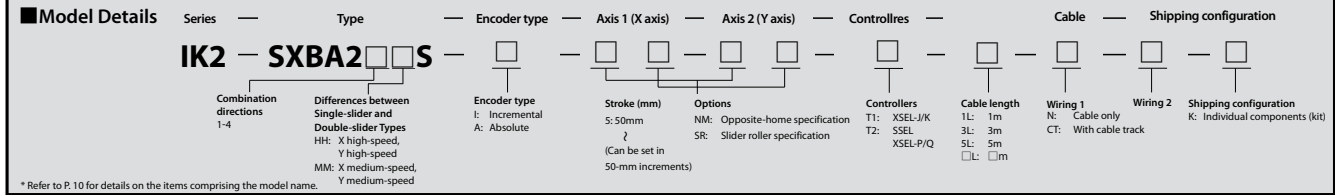

Both wiring 1 and wiring 2 assume use of a cable track.

Maximum Stroke

X axis 1000 mm **Y axis 350 mm**

Maximum Speed

	High-speed type	Medium-speed type
X axis	1000mm/s	500mm/s
Y axis	1000mm/s	500mm/s

Maximum Load Capacity

	X high-speed, Y high-speed	X high-speed, Y high-speed	X medium-speed, Y medium-speed
50mm	12kg	12kg	24kg
100mm	12kg	12kg	20.5kg
150mm	11.5kg	11.5kg	15.5kg
200mm	11kg	11kg	12.5kg
250mm	10kg	10kg	—
300mm	8.5kg	8.5kg	—
350mm	7kg	7kg	—

List by Stroke

Y-axis stroke	Incremental							Absolute						
	50	100	150	200	250	300	350	50	100	150	200	250	300	350
50	-	-	-	-	-	-	-	-	-	-	-	-	-	-
100	-	-	-	-	-	-	-	-	-	-	-	-	-	-
150	-	-	-	-	-	-	-	-	-	-	-	-	-	-
200	-	-	-	-	-	-	-	-	-	-	-	-	-	-
250	-	-	-	-	-	-	-	-	-	-	-	-	-	-
300	-	-	-	-	-	-	-	-	-	-	-	-	-	-
350	-	-	-	-	-	-	-	-	-	-	-	-	-	-
400	-	-	-	-	-	-	-	-	-	-	-	-	-	-
450	-	-	-	-	-	-	-	-	-	-	-	-	-	-
500	-	-	-	-	-	-	-	-	-	-	-	-	-	-
550	-	-	-	-	-	-	-	-	-	-	-	-	-	-
600	-	-	-	-	-	-	-	-	-	-	-	-	-	-
650	-	-	-	-	-	-	-	-	-	-	-	-	-	-
700	-	-	-	-	-	-	-	-	-	-	-	-	-	-
750	-	-	-	-	-	-	-	-	-	-	-	-	-	-
800	-	-	-	-	-	-	-	-	-	-	-	-	-	-
850	-	-	-	-	-	-	-	-	-	-	-	-	-	-
900	-	-	-	-	-	-	-	-	-	-	-	-	-	-
950	-	-	-	-	-	-	-	-	-	-	-	-	-	-
1000	-	-	-	-	-	-	-	-	-	-	-	-	-	-

Note: For the X medium-speed/Y medium-speed type, the Y-axis stroke must be 200 mm or less.

List by Cable Length

Type	Cable code	Length
Standard type	1L	1m
	3L	3m
	5L	5m

* Axis 1 comes with a standard cable, while axis 2 comes with a robot cable.
 * Refer to P. 90 for lengths other than those specified above.

Cable track

Wiring 1 (Next to X-axis)	X-axis stroke	50-300	350-600	650-900	950-1000
Wiring 2 (Next to Y-axis)	Y-axis stroke	50-200	250-300	—	—

List of Options

Name	Option code
Opposite-home specification	NM
Slider roller specification	SR

Axis 1 (X-axis)
Axis 2 (Y-axis)

Specifications

Item	X axis	Y axis
Axis model	RCS2-SS8C	RCS2-SS8R
Stroke (Can be set in 50-mm increments)	50-1000mm	High-speed type: 50-350mm Medium speed type: 50-200mm
Max speed	Stroke	50-600mm
	High speed	650-700mm
	Medium speed	750-800mm
Motor output (W)	150W	100W
Ball screw lead	High-speed type: 20mm Medium-speed type: 10mm	
Drive method	Ball screw, ø16 mm, rolled, C10	
Positioning repeatability	±0.02mm	
Base material	Dedicated alloy steel	
Surrounding air temperature/humidity	0 to 40°C, 85% RH or below (non-condensing)	

Dimensions

You can download CAD drawings from our website.

www.intelligentactuator.com

Note 1. The connected position shown in the drawing defines the home.
 Note 2. Both wiring 1 and wiring 2 assume use of a cable track.
 Note 3. For details on the cable track, refer to P. 90.
 Note 4. For details on the bracket on the moving end of the cable track, refer to P. 90.

* Caution

Customer to prepare the parts and attach the X-axis cable track guide rail to the same plane the X-axis actuator is installed. Also customer to prepare the parts and attach the Y-axis cable track free end (Y-axis slider side) to the customer's bracket on the Y-axis slider.

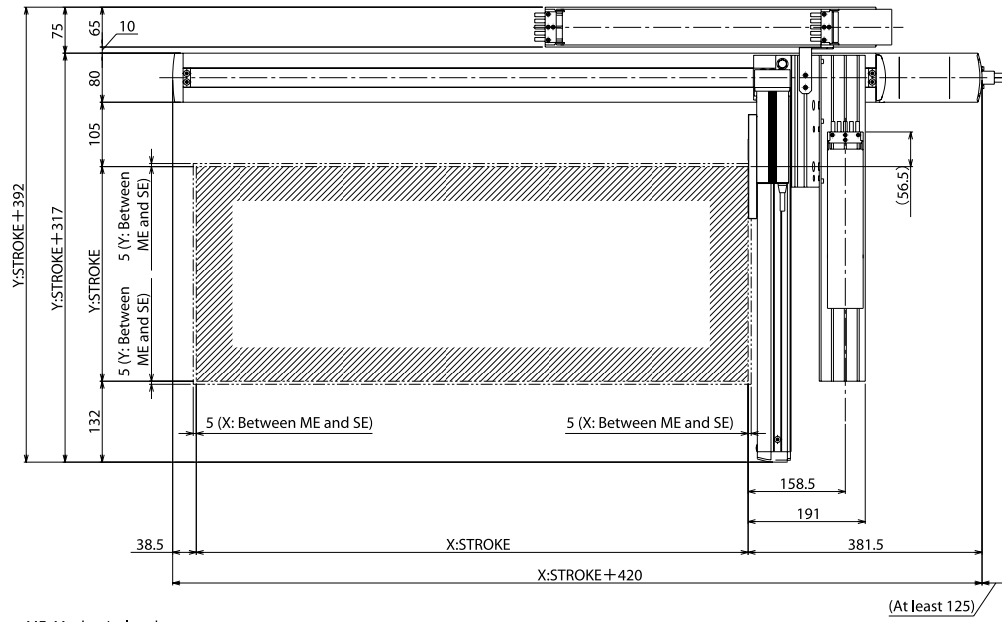
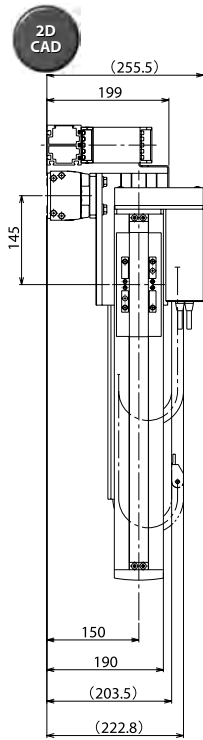

ME: Mechanical end
 SE: Stroke end

45
 (Tolerance for reamed hole pitch: ±0.02)
 4-M8, depth 10
 2-ø8-H7, depth 10

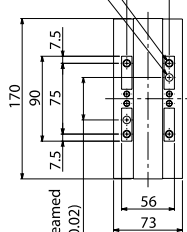

Detail view of Y-axis slider



Detail view of slot in bottom face of X-axis base

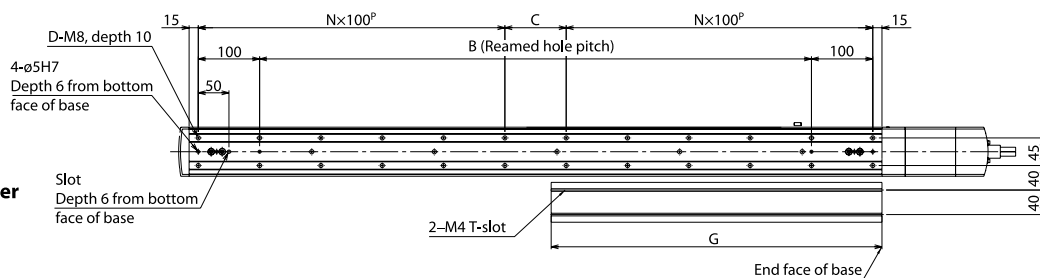
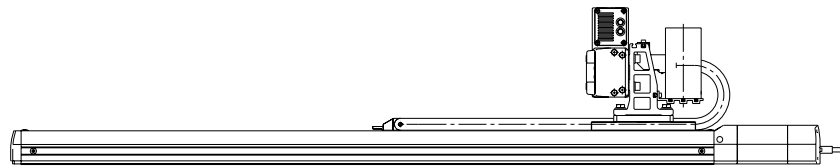

Detail view of X-axis installation

■ Dimensions by Stroke

X: Model	50	100	150	200	250	300	350	400	450	500	550	600	650	700	750	800	850	900	950	1000
B	50	100	150	200	250	300	350	400	450	500	550	600	650	700	750	800	850	900	950	1000
C	50	100	150	0	50	100	150	0	50	100	150	0	50	100	150	0	50	100	150	0
D	8	8	8	10	12	12	12	14	16	16	16	18	20	20	20	22	24	24	24	26
N	1	1	1	2	2	2	2	3	3	3	3	4	4	4	4	5	5	5	5	6
G	114.5	139.5	164.5	189.5	214.5	239.5	264.5	289.5	314.5	339.5	364.5	389.5	414.5	439.5	464.5	489.5	514.5	539.5	564.5	589.5

Controllers

Applicable controller



Refer to P. 91 for the controllers.

IK2-SXBA2□□D

RCS2 2-axis Combinations X axis: SS8C (150W, Straight, Double-slider)
Y axis: SS8R (100W, Reversed)

Model Details

Series: IK2 — Type: SXBA2□□D — Encoder type: □ — Axis 1 (X axis): □ — Axis 2 (Y axis): □ — Controllres: □ — Cable: □ — Shipping configuration: □

Combination directions T-4

Differences between Single-slider and Double-slider Types
 HH: X high-speed, Y high-speed
 MM: X medium-speed, Y medium-speed

Encoder type
 I: Incremental
 A: Absolute

Stroke (mm)
 S: 50mm
 ? (Can be set in 50-mm increments)

Options
 NM: Opposite-home specification
 SR: Slider roller specification

Controllers
 T1: XSEL-J/K
 T2: SSEL
 XSEL-P/Q

Cable length
 1L: 1m
 3L: 3m
 5L: 5m
 □L: □m

Wiring 1
 N: Cable only
 CT: With cable track

Wiring 2

Shipping configuration
 K: Individual components (kit)

* Refer to P.10 for details on the items comprising the model name.

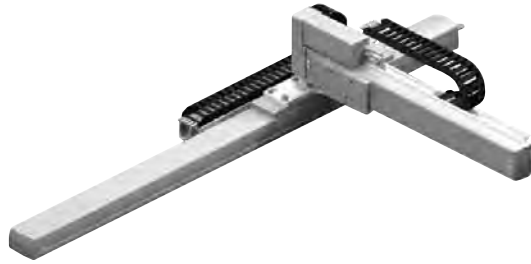

Both wiring 1 and wiring 2 assume use of a cable track.

Maximum Stroke

X axis 800 mm **Y axis** 400 mm

Maximum Speed

	High-speed type	Medium-speed type
X axis	1000mm/s	500mm/s
Y axis	1000mm/s	500mm/s

Maximum Load Capacity

Y-axis stroke	X high-speed, Y high-speed	X medium-speed, Y medium-speed
100mm	—	24kg
150mm	—	24kg
200mm	—	23kg
250mm	—	19kg
300mm	11kg	16kg
350mm	10.5kg	13.5kg
400mm	10kg	11.5kg

List by Stroke

Y-axis stroke	Incremental								Absolute							
	100	150	200	250	300	350	400	100	150	200	250	300	350	400		
50	-	-	-	-	-	-	-	-	-	-	-	-	-	-		
100	-	-	-	-	-	-	-	-	-	-	-	-	-	-		
150	-	-	-	-	-	-	-	-	-	-	-	-	-	-		
200	-	-	-	-	-	-	-	-	-	-	-	-	-	-		
250	-	-	-	-	-	-	-	-	-	-	-	-	-	-		
300	-	-	-	-	-	-	-	-	-	-	-	-	-	-		
350	-	-	-	-	-	-	-	-	-	-	-	-	-	-		
400	-	-	-	-	-	-	-	-	-	-	-	-	-	-		
450	-	-	-	-	-	-	-	-	-	-	-	-	-	-		
500	-	-	-	-	-	-	-	-	-	-	-	-	-	-		
550	-	-	-	-	-	-	-	-	-	-	-	-	-	-		
600	-	-	-	-	-	-	-	-	-	-	-	-	-	-		
650	-	-	-	-	-	-	-	-	-	-	-	-	-	-		
700	-	-	-	-	-	-	-	-	-	-	-	-	-	-		
750	-	-	-	-	-	-	-	-	-	-	-	-	-	-		
800	-	-	-	-	-	-	-	-	-	-	-	-	-	-		

Note: For the X high-speed/Y high-speed type, the Y-axis stroke must be 300 mm or more.

List by Cable Length

Type	Cable code	Length
Standard type	1L	1m
	3L	3m
	5L	5m

* Axis 1 comes with a standard cable, while axis 2 comes with a robot cable.
 * Refer to P.90 for lengths other than those specified above.

Cable track

Wiring 1 (Next to X-axis)	X-axis stroke	50-300	350-600	650-800
Wiring 2 (Next to Y-axis)	Y-axis stroke	200	250-400	—

List of Options

Name	Option code	
Opposite-home specification	NM	
Slider roller specification	SR	Axis 1 (X-axis) Axis 2 (Y-axis)

Specifications

Item	X axis	Y axis
Axis model	RCS2-SS8C	RCS2-SS8R
Stroke (Can be set in 50-mm increments)	50-800mm	High-speed type: 300-400mm Medium speed type: 100-400mm
Max speed	Stroke High speed Medium speed	100-400mm 1000mm/s 500mm/s
Motor output (W)	150W	100W
Ball screw lead	High-speed type: 20mm Medium-speed type: 10mm	
Drive method	Ball screw, ø16 mm, rolled, C10	
Positioning repeatability	±0.02mm	
Base material	Dedicated alloy steel	
Surrounding air temperature/humidity	0 to 40°C, 85% RH or below (non-condensing)	

Dimensions

You can download CAD drawings from our website. www.intelligentactuator.com

- Note 1. The connected position shown in the drawing defines the home.
- Note 2. Both wiring 1 and wiring 2 assume use of a cable track.
- Note 3. For details on the cable track, refer to P. 90.
- Note 4. For details on the bracket on the moving end of the cable track, refer to P. 90.

* Caution

Customer to prepare the parts and attach the X-axis cable track guide rail to the same plane the X-axis actuator is installed. Also customer to prepare the parts and attach the Y-axis cable track free end (Y-axis slider side) to the customer's bracket on the Y-axis slider.

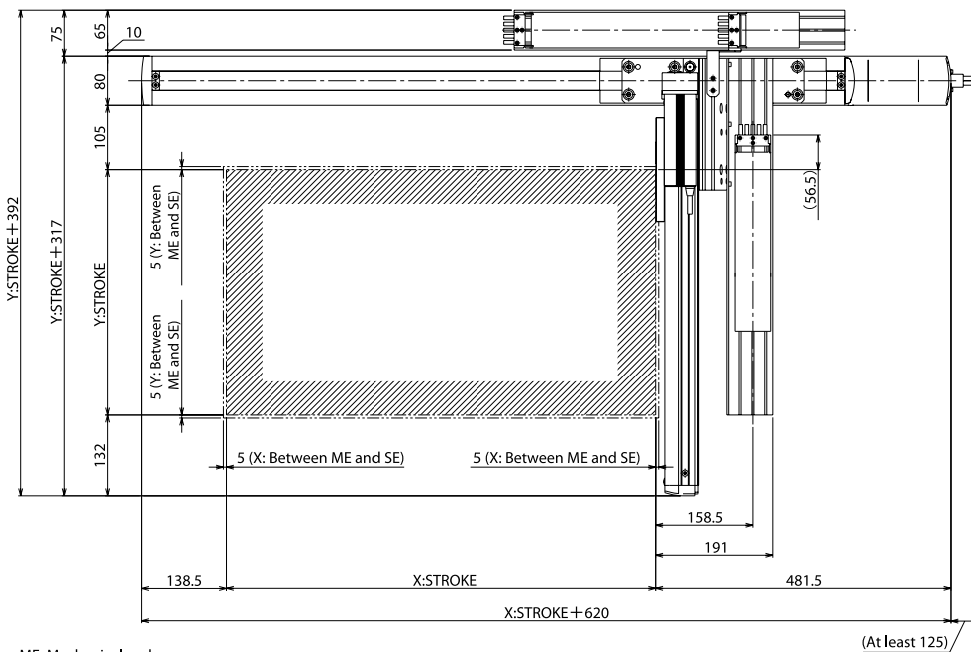
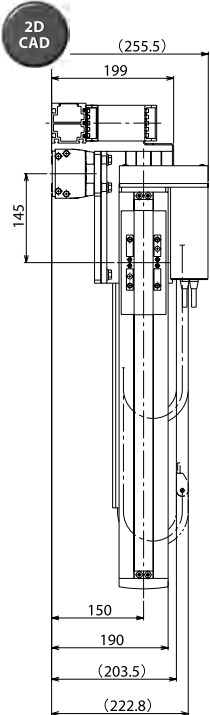

45 ME: Mechanical end
(Tolerance for reamed hole pitch: ±0.02) SE: Stroke end

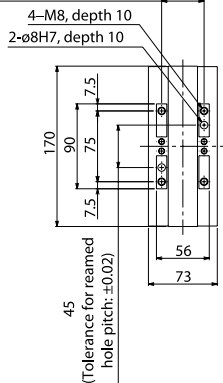

Detail view of Y-axis slider

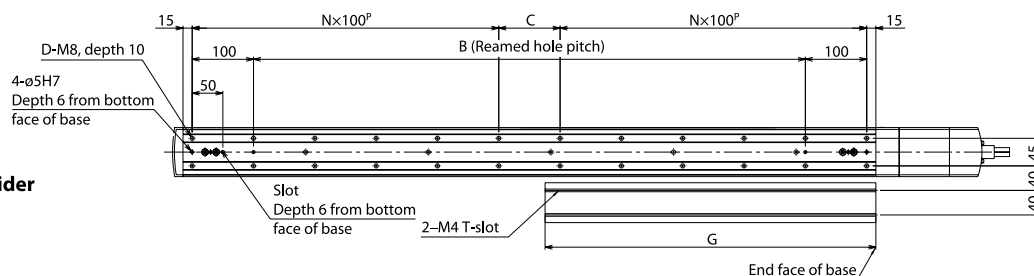
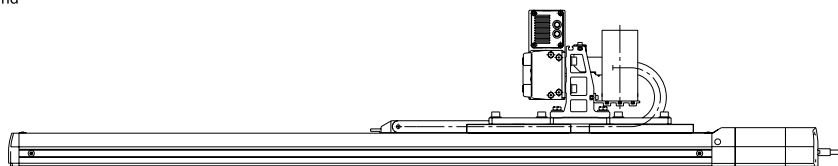

Detail view of X-axis installation

Detail view of slot in bottom face of X-axis base



■ Dimensions by Stroke

X: Nominal stroke	250	300	350	400	450	500	550	600	650	700	750	800	850	900	950	1000
X: Effective stroke	50	100	150	200	250	300	350	400	450	500	550	600	650	700	750	800
B	250	300	350	400	450	500	550	600	650	700	750	800	850	900	950	1000
C	50	100	150	0	50	100	150	0	50	100	150	0	50	100	150	0
D	12	12	12	14	16	16	16	18	20	20	20	22	24	24	24	26
N	2	2	2	3	3	3	3	4	4	4	4	5	5	5	5	6
G	214.5	239.5	264.5	289.5	314.5	339.5	364.5	389.5	414.5	439.5	464.5	489.5	514.5	539.5	564.5	589.5

Controllers

Applicable controller

Refer to P. 91 for the controllers.

IK2-SXZB1□□S

RCS2 2-axis combination (XZ) X axis: S58R (100W, Reversed, Single-slider)
Z axis: SA7R (Reversed)

Model Details

Series: **IK2** | Type: **SXZB1□□S** | Encoder type: **□** | Axis 1 (X axis): **□** | Axis 2 (Z axis): **B□** | Controller: **□** | Cable: **□** | Shipping configuration: **□**

Encoder type
I: Incremental
A: Absolute

Stroke (mm)
5: 50mm
□: (Can be set in 50-mm increments)

Options
B: Brake
NM: Opposite-home specification
SR: Slider roller specification

Controllers
T1: XSEL-J/K
T2: SSEL
XSEL-P/Q

Cable length
1L: 1m
3L: 3m
5L: 5m
□L: □m

Wiring 1
N: Cable only
CT: With cable track

Wiring 2
□

Shipping configuration
K: Individual components (kit)

Differences between Single-slider and Double-slider Types
HH: X high-speed, Z high-speed
HM: X high-speed, Z medium-speed
HL: X high-speed, Z low-speed

Combination directions
1-4

* Refer to P.10 for details on the items comprising the model name.

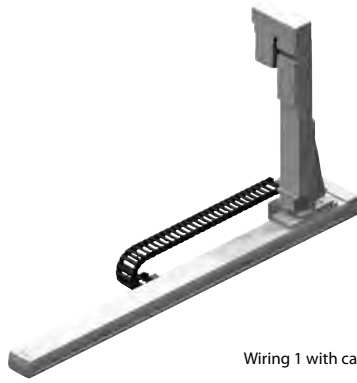

Wiring 1 with cable track

Maximum Stroke

X axis 1000 mm | **Z axis** 250 mm

Maximum Speed

	High-speed type	Medium-speed type	Low-speed type
X axis	1000mm/s	-	-
Z axis	800mm/s	400mm/s	200mm/s

Maximum Load Capacity

Z-axis stroke	Z-axis high-speed, lead 16	Z-axis medium-speed, lead 8	Z-axis low-speed, lead 4
50mm	2.0kg	4.0kg	8.0kg
100mm	2.0kg	4.0kg	7.0kg
150mm	2.0kg	3.5kg	5.0kg
200mm	2.0kg	3.5kg	4.0kg
250mm	1.5kg	2.5kg	3.0kg

List by Stroke

Z-axis stroke	Incremental					Absolute				
	50	100	150	200	250	50	100	150	200	250
50	-	-	-	-	-	-	-	-	-	-
100	-	-	-	-	-	-	-	-	-	-
150	-	-	-	-	-	-	-	-	-	-
200	-	-	-	-	-	-	-	-	-	-
250	-	-	-	-	-	-	-	-	-	-
300	-	-	-	-	-	-	-	-	-	-
350	-	-	-	-	-	-	-	-	-	-
400	-	-	-	-	-	-	-	-	-	-
450	-	-	-	-	-	-	-	-	-	-
500	-	-	-	-	-	-	-	-	-	-
550	-	-	-	-	-	-	-	-	-	-
600	-	-	-	-	-	-	-	-	-	-
650	-	-	-	-	-	-	-	-	-	-
700	-	-	-	-	-	-	-	-	-	-
750	-	-	-	-	-	-	-	-	-	-
800	-	-	-	-	-	-	-	-	-	-
850	-	-	-	-	-	-	-	-	-	-
900	-	-	-	-	-	-	-	-	-	-
950	-	-	-	-	-	-	-	-	-	-
1000	-	-	-	-	-	-	-	-	-	-

List by Cable Length

Type	Cable code	Length
Standard type	1L	1m
	3L	3m
	5L	5m

* Axis 1 comes with a standard cable, while axis 2 comes with a robot cable.
* Refer to P.90 for lengths other than those specified above.

Cable track

Wiring 1 (Next to X-axis)	X-axis stroke	150-300	350-600	650-900	950-1000

List of Options

Name	Option code	
Opposite-home specification	NM	
Slider roller specification	SR	Axis 1 (X-axis) Axis 2 (Z-axis)

Specifications

Item	X axis						Z axis
Axis model	RCS2-S58R						RCS2-SA7R
Stroke (Can be set in 50-mm increments)	50-1000mm						50-250mm
Max speed	Stroke	50-600mm	650-700mm	750-800mm	850-900mm	950-1000mm	50-250mm
	High speed	1000mm/s	960mm/s	765mm/s	625mm/s	515mm/s	800mm/s
	Medium speed	-	-	-	-	-	400mm/s
	Low speed	-	-	-	-	-	200mm/s
Motor output (W)	100W						60W
Ball screw lead	High-speed type: 20mm						High-speed type: 16mm Medium-speed type: 8mm Low-speed type: 4mm
Drive method	Ball screw, ø16 mm, rolled, C10						Ball screw, ø12 mm, rolled, C10
Positioning repeatability	±0.02mm						
Base material	Dedicated alloy steel						Aluminum
Surrounding air temperature/humidity	0 to 40°C, 85% RH or below (non-condensing)						

Dimensions

You can download CAD drawings from our website.

www.intelligentactuator.com

2D CAD

Note 1. The connected position shown in the drawing defines the home.
 Note 2. Both wiring 1 and wiring 2 assume use of a cable track.
 Note 3. For details on the cable track, refer to P. 90.
 Note 4. For details on the bracket on the moving end of the cable track, refer to P. 90.

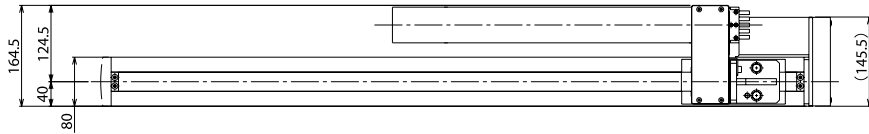

* Caution
 Customer to prepare the parts and attach X-axis cable track fix end (non-slider side) to the same plane the X-axis actuator is installed. (There is no cable track guide rail.)

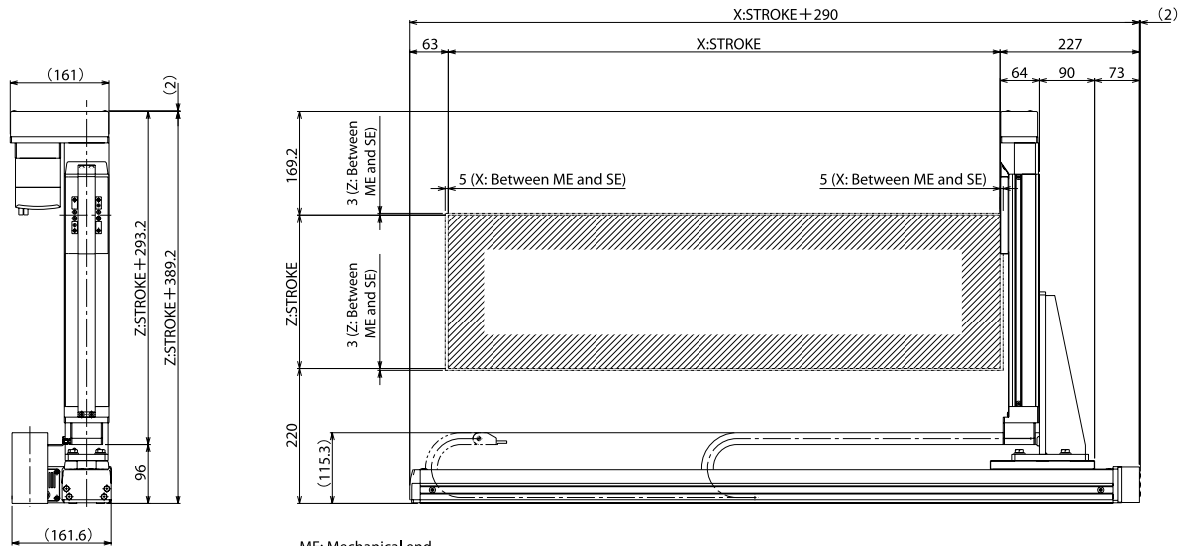

ME: Mechanical end
 SE: Stroke end

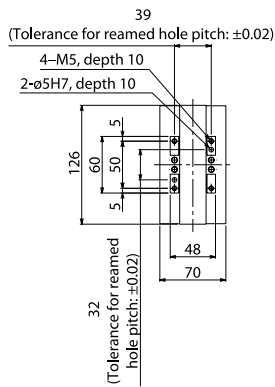

Detail view of Z-axis slider

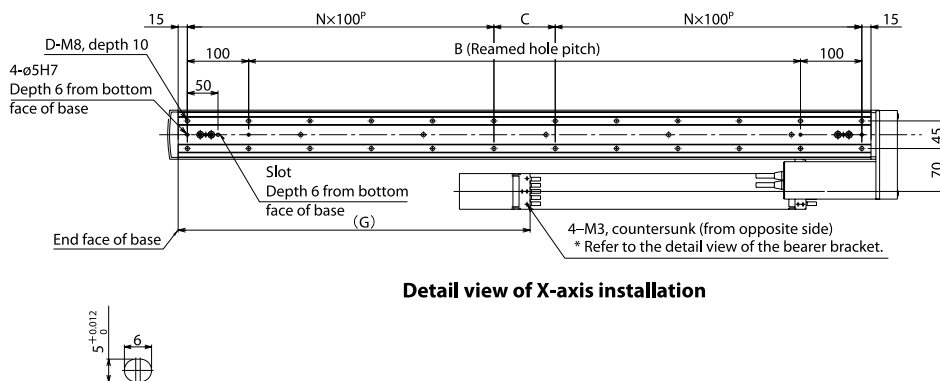

Detail view of slot in bottom face of X-axis base

Detail view of X-axis installation

Dimensions by Stroke

X: Model	50	100	150	200	250	300	350	400	450	500	550	600	650	700	750	800	850	900	950	1000
B	50	100	150	200	250	300	350	400	450	500	550	600	650	700	750	800	850	900	950	1000
C	50	100	150	0	50	100	150	0	50	100	150	0	50	100	150	0	50	100	150	0
D	8	8	8	10	12	12	12	14	16	16	16	18	20	20	20	22	24	24	24	26
N	1	1	1	2	2	2	2	3	3	3	3	4	4	4	4	5	5	5	5	6
G	-	-	199	224	249	274	299	324	349	374	399	424	449	474	499	524	549	574	599	624

* A bearer is not set when the X stroke is 50 or 100.

Controllers

Applicable controller

Refer to P. 91 for the controllers.

IK2-SXZB1 □ □ D

RCS2 2-axis Combinations(XZ)

X axis: SS8R (100W, Reversed, Double-slider)

Z axis: SA7R (Reversed)

Model Details

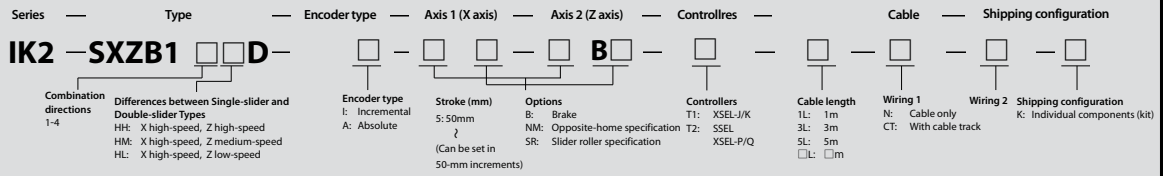

* Refer to P.10 for details on the items comprising the model name.

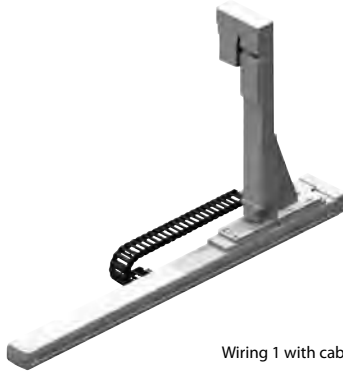

Wiring 1 with cable track

Maximum Stroke

X axis 800 mm

Z axis 300 mm

Maximum Speed

	High-speed type	Medium-speed type	Low-speed type
X axis	1000mm/s	-	-
Z axis	800mm/s	400mm/s	200mm/s

Maximum Load Capacity

Z-axis stroke	Z-axis high-speed, lead 16	Z-axis medium-speed, lead 8	Z-axis low-speed, lead 4
150mm	-	-	7.0kg
200mm	-	-	7.0kg
250mm	-	-	5.5kg
300mm	1.5kg	3.0kg	5.5kg

List by Stroke

Y-axis stroke	Incremental				Absolute			
	150	200	250	300	150	200	250	300
50	-	-	-	-	-	-	-	-
100	-	-	-	-	-	-	-	-
150	-	-	-	-	-	-	-	-
200	-	-	-	-	-	-	-	-
250	-	-	-	-	-	-	-	-
300	-	-	-	-	-	-	-	-
350	-	-	-	-	-	-	-	-
400	-	-	-	-	-	-	-	-
450	-	-	-	-	-	-	-	-
500	-	-	-	-	-	-	-	-
550	-	-	-	-	-	-	-	-
600	-	-	-	-	-	-	-	-
650	-	-	-	-	-	-	-	-
700	-	-	-	-	-	-	-	-
750	-	-	-	-	-	-	-	-
800	-	-	-	-	-	-	-	-

Note: For the Z high-speed type and Z medium-speed type, The Z-axis stroke is limited to 300 mm.

List by Cable Length

Type	Cable code	Length
Standard type	1L	1m
	3L	3m
	5L	5m

* Axis 1 comes with a standard cable, while axis 2 comes with a robot cable.

* Refer to P.90 for lengths other than those specified above.

Cable track

Wiring 1 (Next to X-axis)	X-axis stroke	150-300	350-600	650-800

List of Options

Name	Option code	
Opposite-home specification	NM	
Slider roller specification	SR	Axis 1 (X-axis) Axis 2 (Z-axis)

Specifications

Item	X axis	Z axis
Axis model	RCS2-SS8R	RCS2-SA7R
Stroke (Can be set in 50-mm increments)	50-800mm	High-speed type: 300mm Medium-speed type: 300mm Low-speed type: 150-300mm
Max speed	Stroke High speed Medium speed Low speed	150-300mm 800mm/s 400mm/s 200mm/s
Motor output (W)	100W	60W
Ball screw lead	High-speed type: 20mm	High-speed type: 16mm Medium-speed type: 8mm Low-speed type: 4mm
Drive method	Ball screw, ø16 mm, rolled, C10	Ball screw, ø12 mm, rolled, C10
Positioning repeatability	±0.02mm	
Base material	Dedicated alloy steel	Aluminum
Surrounding air temperature/humidity	0 to 40°C, 85% RH or below (non-condensing)	

Dimensions

You can download CAD drawings from our website.

www.intelligentactuator.com

2D CAD

Note 1. The connected position shown in the drawing defines the home.
 Note 2. Both wiring 1 and wiring 2 assume use of a cable track.
 Note 3. For details on the cable track, refer to P. 90.
 Note 4. For details on the bracket on the moving end of the cable track, refer to P. 90.

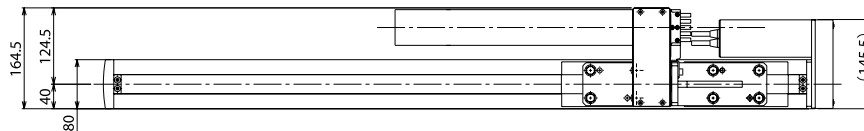

* Caution
 Customer to prepare the parts and attach X-axis cable track fix end (non-slider side) to the same plane the X-axis actuator is installed. (There is no cable track guide rail.)

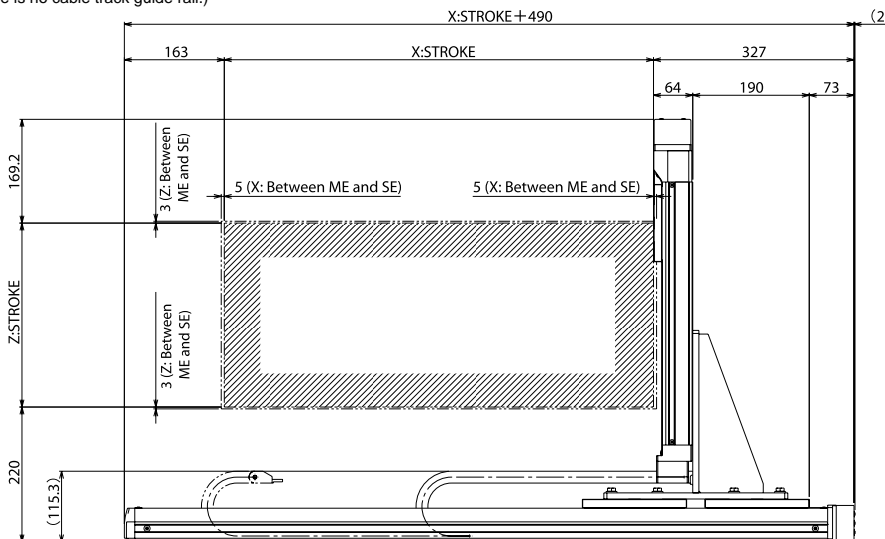
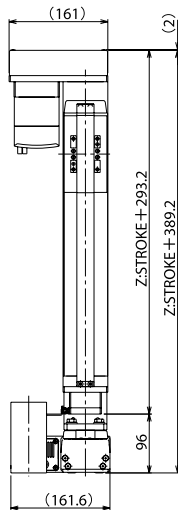

ME: Mechanical end
 SE: Stroke end

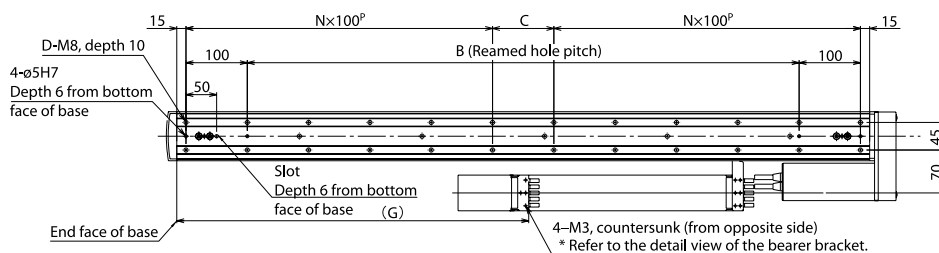
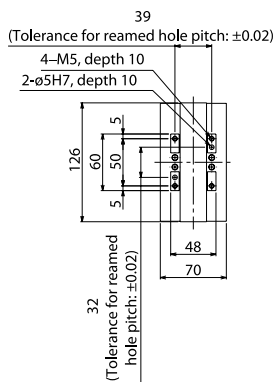

Detail view of X-axis installation

Detail view of Z-axis slider



Detail view of slot in bottom face of X-axis base

■ Dimensions by Stroke

X: Nominal stroke	250	300	350	400	450	500	550	600	650	700	750	800	850	900	950	1000
X: Effective stroke	50	100	150	200	250	300	350	400	450	500	550	600	650	700	750	800
B	250	300	350	400	450	500	550	600	650	700	750	800	850	900	950	1000
C	50	100	150	0	50	100	150	0	50	100	150	0	50	100	150	0
D	12	12	12	14	16	16	16	18	20	20	20	22	24	24	24	26
N	2	2	2	3	3	3	3	4	4	4	4	5	5	5	5	6
G	-	-	299	324	349	374	399	424	449	474	499	524	549	574	599	624

* A bearer is not set when the X stroke is 50 or 100.

Controllers

Applicable controller



Refer to P. 91 for the controllers.

IK2-SYBB1□□S

RCS2 2-axis combination (YZ) Y axis: SS8R (100W, Reversed, Single-slider)
Z axis: SA7R (Reversed)

Model Details Series — Type — Encoder type — Axis 1 (Y axis) — Axis 2 (Z axis) — Controller — Cable — Shipping configuration

IK2 — SYBB1□□S

Combination directions 1-2
Differences between Single-slider and Double-slider Types
HH: Y high-speed, Z high-speed
HM: Y high-speed, Z medium-speed
HL: Y high-speed, Z low-speed

Encoder type
I: Incremental
A: Absolute

Stroke (mm)
5: 50mm
Z
(Can be set in 50-mm increments)

Options
B: Brake
NM: Opposite-home specification
SR: Slider roller specification

Controllers
T1: XSEL-I/K
T2: SSEL
XSEL-P/Q

Cable length
1L: 1m
3L: 3m
5L: 5m
□L: □m

Wiring 1
N: Cable only
CT: With cable track

Wiring 2

Shipping configuration
K: Individual components (kit)

* Refer to P.10 for details on the items comprising the model name.

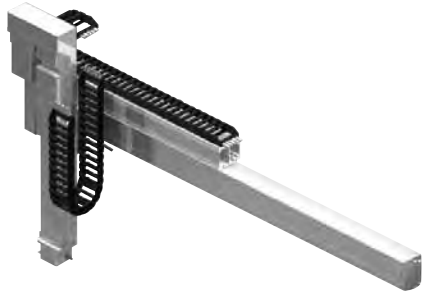

Both wiring 1 and wiring 2 assume use of a cable track.

Maximum Stroke

Y axis 1000 mm **Z axis** 300 mm

Maximum Speed

	High-speed type	Medium-speed type	Low-speed type
Y axis	1000mm/s	-	-
Z axis	800mm/s	400mm/s	200mm/s

Maximum Load Capacity

Z-axis stroke	Z-axis high-speed, lead 16	Z-axis medium-speed, lead 8	Z-axis low-speed, lead 4
50mm	2.0kg	4.0kg	8.0kg
100mm	2.0kg	4.0kg	8.0kg
150mm	2.0kg	3.5kg	7.0kg
200mm	2.0kg	3.5kg	7.0kg
250mm	1.5kg	3.0kg	6.0kg
300mm	1.5kg	3.0kg	5.5kg

List by Stroke

Z-axis stroke	Incremental						Absolute					
	50	100	150	200	250	300	50	100	150	200	250	300
50	-	-	-	-	-	-	-	-	-	-	-	-
100	-	-	-	-	-	-	-	-	-	-	-	-
150	-	-	-	-	-	-	-	-	-	-	-	-
200	-	-	-	-	-	-	-	-	-	-	-	-
250	-	-	-	-	-	-	-	-	-	-	-	-
300	-	-	-	-	-	-	-	-	-	-	-	-
350	-	-	-	-	-	-	-	-	-	-	-	-
400	-	-	-	-	-	-	-	-	-	-	-	-
450	-	-	-	-	-	-	-	-	-	-	-	-
500	-	-	-	-	-	-	-	-	-	-	-	-
550	-	-	-	-	-	-	-	-	-	-	-	-
600	-	-	-	-	-	-	-	-	-	-	-	-
650	-	-	-	-	-	-	-	-	-	-	-	-
700	-	-	-	-	-	-	-	-	-	-	-	-
750	-	-	-	-	-	-	-	-	-	-	-	-
800	-	-	-	-	-	-	-	-	-	-	-	-
850	-	-	-	-	-	-	-	-	-	-	-	-
900	-	-	-	-	-	-	-	-	-	-	-	-
950	-	-	-	-	-	-	-	-	-	-	-	-
1000	-	-	-	-	-	-	-	-	-	-	-	-

List by Cable Length

Type	Cable code	Length
Standard type	1L	1m
	3L	3m
	5L	5m

* Axis 1 comes with a standard cable, while axis 2 comes with a robot cable.
* Refer to P. 90 for lengths other than those specified above.

Cable track

Wiring 1 (Next to Y-axis)	Y-axis stroke	50-300	350-600	650-900	950-1000
Wiring 2 (Next to Z-axis)	Z-axis stroke	50-200	250-300	-	-

List of Options

Name	Option code	
Opposite-home specification	NM	
Slider roller specification	SR	Axis 1 (Y-axis) Axis 2 (Z-axis)

Specifications

Item	Y axis	Z axis
Axis model	RCS2-SS8R	RCS2-SA7R
Stroke (Can be set in 50-mm increments)	50-1000mm	50-300mm
Max speed	Stroke	50-600mm
	High speed	650-700mm
	Medium speed	750-800mm
	Low speed	850-900mm
Motor output (W)	100W	60W
Ball screw lead	High-speed type: 20mm	High-speed type: 16mm Medium-speed type: 8mm Low-speed type: 4mm
Drive method	Ball screw, ø16 mm, rolled, C10	Ball screw, ø12 mm, rolled, C10
Positioning repeatability	±0.02mm	
Base material	Dedicated alloy steel	Aluminum
Surrounding air temperature/humidity	0 to 40°C, 85% RH or below (non-condensing)	

Dimensions

You can download CAD drawings from our website.

www.intelligentactuator.com

2D CAD

Note 1. The connected position shown in the drawing defines the home.
 Note 2. Both wiring 1 and wiring 2 assume use of a cable track.
 Note 3. For details on the cable track, refer to P. 90.
 Note 4. For details on the bracket on the moving end of the cable track, refer to P. 90.

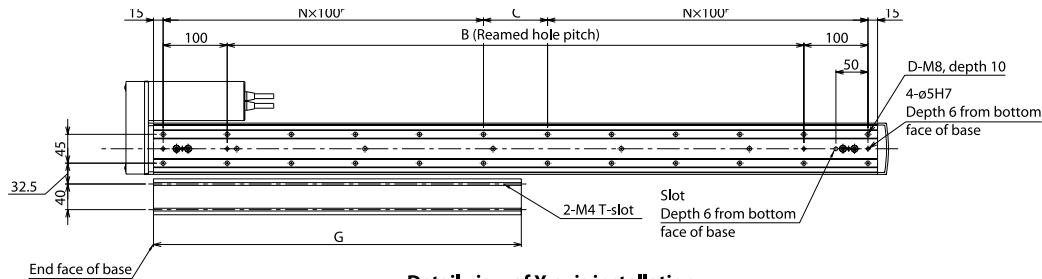

Detail view of Y-axis installation

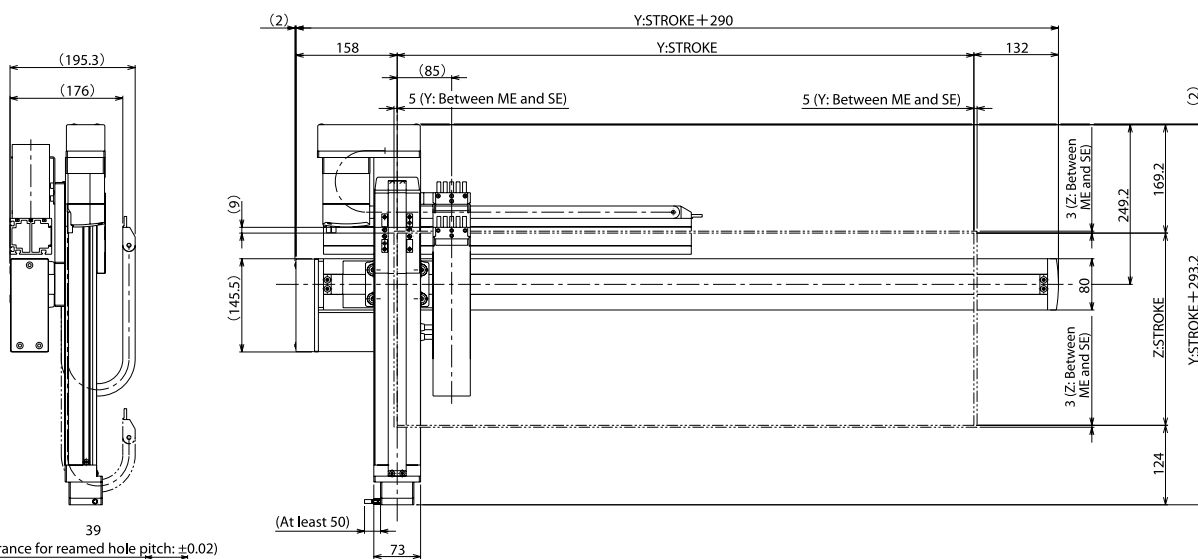
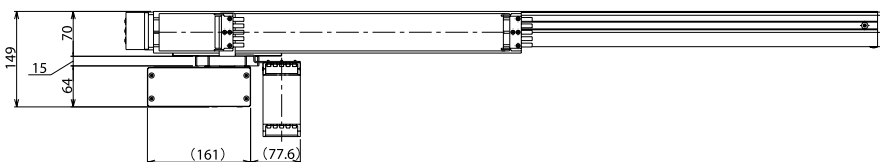

ME: Mechanical end
 SE: Stroke end

* Caution
 Customer to prepare the parts and attach Y-axis cable track guide rail to the same plane the Y-axis actuator is installed. Also customer to prepare the parts and attach Z-axis cable track free end (Z-axis slider side) to the customer's bracket on the Z-axis slider.

Detail view of Z-axis slider Detail view of slot in bottom face of Y-axis base

Dimensions by Stroke

Y: Model	50	100	150	200	250	300	350	400	450	500	550	600	650	700	750	800	850	900	950	1000
B	50	100	150	200	250	300	350	400	450	500	550	600	650	700	750	800	850	900	950	1000
C	50	100	150	0	50	100	150	0	50	100	150	0	50	100	150	0	50	100	150	0
D	8	8	8	10	12	12	12	14	16	16	16	18	20	20	20	22	24	24	24	26
N	1	1	1	2	2	2	2	3	3	3	3	4	4	4	4	5	5	5	5	6
G	149	174	199	224	249	274	299	324	349	374	399	424	449	474	499	524	549	574	599	624

Controllers

Applicable controller

Refer to P. 91 for the controllers.

IK3-PBBG1□□S

RCP2 3-axis combination (XYB+Z-axis, base mount)

X axis: SS8R (Reversed, Single-slider)

Y axis: SA7R (Reversed) Z axis: SA6R (Reversed)

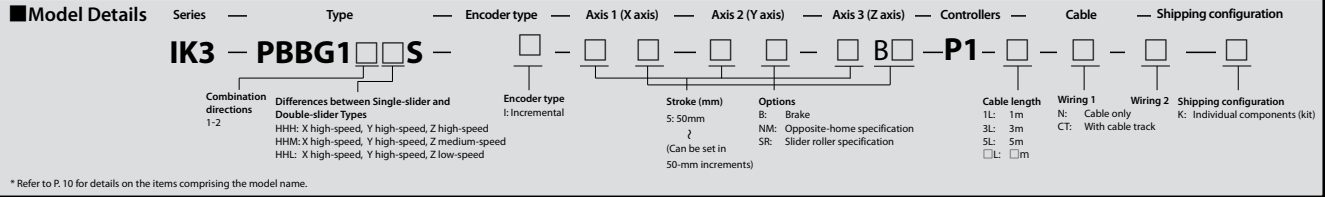

With cable tracks (Wiring 3 does not come with a cable track.)

Maximum Stroke

X axis 1000 mm Y axis 300 mm Z axis 200 mm

Maximum Speed

	X high-speed, Y high-speed, Z high-speed	X high-speed, Y high-speed, Z medium-speed	X high-speed, Y high-speed, Z low-speed
X axis	220mm/s		
Y axis	420mm/s		
Z axis	500mm/s	250mm/s	125mm/s

Maximum Load Capacity

Y-axis stroke	X high-speed, Y high-speed, Z high-speed	X high-speed, Y high-speed, Z medium-speed	X high-speed, Y high-speed, Z low-speed
50mm	1.0kg	2.0kg	4.0kg
100mm			
150mm			
200mm			
250mm			
300mm			

List by Stroke

Y-axis stroke	Incremental											
	50				100				150			
Z-axis stroke	50	100	150	200	50	100	150	200	50	100	150	200
X-axis stroke 50	-	-	-	-	-	-	-	-	-	-	-	-
100	-	-	-	-	-	-	-	-	-	-	-	-
150	-	-	-	-	-	-	-	-	-	-	-	-
200	-	-	-	-	-	-	-	-	-	-	-	-
250	-	-	-	-	-	-	-	-	-	-	-	-
300	-	-	-	-	-	-	-	-	-	-	-	-
350	-	-	-	-	-	-	-	-	-	-	-	-
400	-	-	-	-	-	-	-	-	-	-	-	-
450	-	-	-	-	-	-	-	-	-	-	-	-
500	-	-	-	-	-	-	-	-	-	-	-	-
550	-	-	-	-	-	-	-	-	-	-	-	-
600	-	-	-	-	-	-	-	-	-	-	-	-
650	-	-	-	-	-	-	-	-	-	-	-	-
700	-	-	-	-	-	-	-	-	-	-	-	-
750	-	-	-	-	-	-	-	-	-	-	-	-
800	-	-	-	-	-	-	-	-	-	-	-	-
850	-	-	-	-	-	-	-	-	-	-	-	-
900	-	-	-	-	-	-	-	-	-	-	-	-
950	-	-	-	-	-	-	-	-	-	-	-	-
1000	-	-	-	-	-	-	-	-	-	-	-	-

Y-axis stroke	Incremental											
	200				250				300			
Z-axis stroke	50	100	150	200	50	100	150	200	50	100	150	200
X-axis stroke 50	-	-	-	-	-	-	-	-	-	-	-	-
100	-	-	-	-	-	-	-	-	-	-	-	-
150	-	-	-	-	-	-	-	-	-	-	-	-
200	-	-	-	-	-	-	-	-	-	-	-	-
250	-	-	-	-	-	-	-	-	-	-	-	-
300	-	-	-	-	-	-	-	-	-	-	-	-
350	-	-	-	-	-	-	-	-	-	-	-	-
400	-	-	-	-	-	-	-	-	-	-	-	-
450	-	-	-	-	-	-	-	-	-	-	-	-
500	-	-	-	-	-	-	-	-	-	-	-	-
550	-	-	-	-	-	-	-	-	-	-	-	-
600	-	-	-	-	-	-	-	-	-	-	-	-
650	-	-	-	-	-	-	-	-	-	-	-	-
700	-	-	-	-	-	-	-	-	-	-	-	-
750	-	-	-	-	-	-	-	-	-	-	-	-
800	-	-	-	-	-	-	-	-	-	-	-	-
850	-	-	-	-	-	-	-	-	-	-	-	-
900	-	-	-	-	-	-	-	-	-	-	-	-
950	-	-	-	-	-	-	-	-	-	-	-	-
1000	-	-	-	-	-	-	-	-	-	-	-	-

Cable track

X-axis stroke	Y-axis stroke	
	50-200	250-300
50-400	-	-
450-600	-	-
650-800	-	-
850-1000	-	-

Note) Both wiring 1 and wiring 2 should have a cable bear, or neither of the two should have a cable track. A cable track cannot be specified for one of the wirings.

List by Cable Length

Name	Option code
Opposite-home specification	NM
Slider roller specification	SR

List by Cable Length

Type	Cable code	Length
Standard type	1L	1m
	3L	3m
	5L	5m

* Axis 1 comes with a standard cable, while axes 2 and 3 come with a robot cable.
 * Refer to P.90 for lengths other than those specified above.

Specifications

Item	X axis	Y axis	Z axis
Axis model	RCP2-SS8R	RCP2-SA7R	RCP2-SA6R
Stroke (Can be set in 50-mm increments)	50-1000mm	50-300mm	50-200mm
Axis 2	High-speed type: 220mm/s	High-speed type: 420mm/s	High-speed type: 500mm/s Medium-speed type: 250mm/s Low-speed type: 125mm/s
Motor size	56-square pulse motor	56-square pulse motor	42-square pulse motor
Ball screw lead	High-speed type: 20mm	High-speed type: 16mm	High-speed type: 12mm Medium-speed type: 6mm Low-speed type: 3mm
Drive method	Ball screw, $\phi 16$ mm, rolled, C10	Ball screw, $\phi 12$ mm, rolled, C10	Ball screw, $\phi 10$ mm, rolled, C10
Positioning repeatability	± 0.02 mm		
Base material	Dedicated alloy steel	Aluminum	
Surrounding air temperature/humidity	0 to 40°C, 85% RH or below (non-condensing)		

Dimensions

You can download CAD drawings from our website. www.intelligentactuator.com

Note 1. The connected position shown in the drawing defines the home.
 Note 2. The drawing below assumes that both wiring 1 and wiring 2 have a cable track.
 Note 3. For details on the cable track, refer to P. 90.

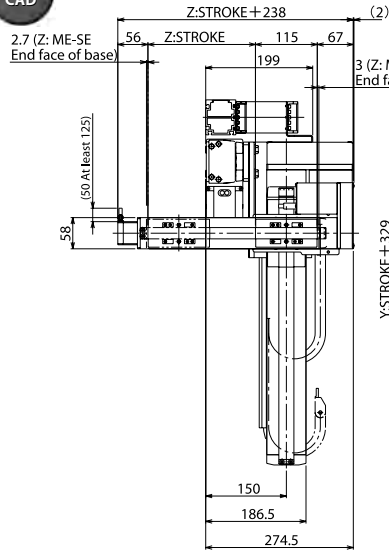

* Caution
 Customer to prepare the parts and attach the X-axis cable track guide rail to the same plane the X-axis actuator is installed.

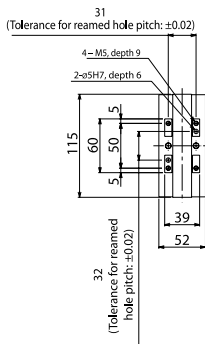
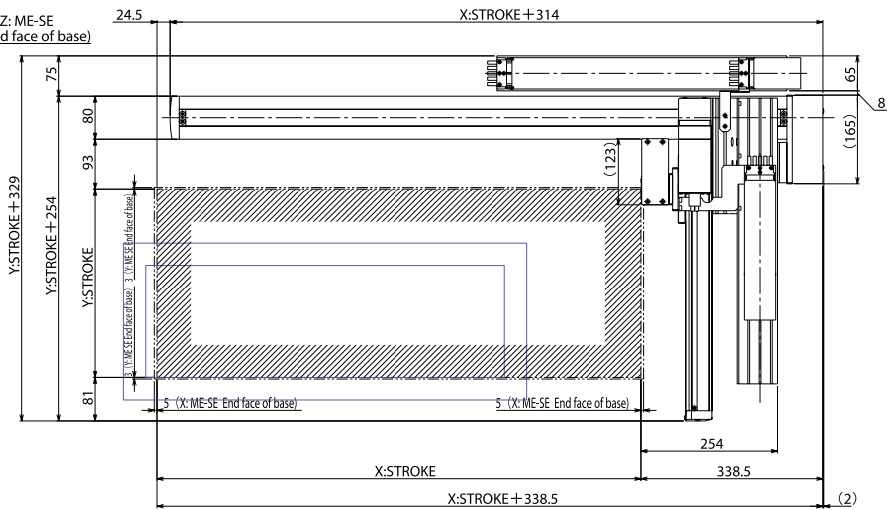

Detail view of Z-axis slider



Detail view of slot in bottom face of X-axis base

ME: Mechanical end
 SE: Stroke end

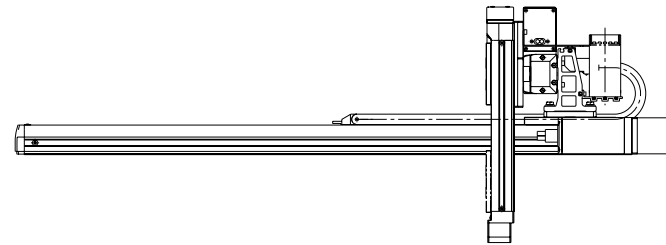

Detail view of X-axis installation

Dimensions by Stroke

X: Model	50	100	150	200	250	300	350	400	450	500	550	600	650	700	750	800	850	900	950	1000
B	50	100	150	200	250	300	350	400	450	500	550	600	650	700	750	800	850	900	950	1000
C	50	100	150	0	50	100	150	0	50	100	150	0	50	100	150	0	50	100	150	0
D	8	8	8	10	12	12	12	14	16	16	16	18	20	20	20	22	24	24	24	26
N	1	1	1	2	2	2	2	3	3	3	3	4	4	4	4	5	5	5	5	6
G	114.5	139.5	164.5	189.5	214.5	239.5	264.5	289.5	314.5	339.5	364.5	389.5	414.5	439.5	464.5	489.5	514.5	539.5	564.5	589.5

Controllers

Applicable controller

Refer to P. 91 for the controllers.

IK3-PBBG1□□D

RCP2 3-axis combination (XYB+Z-axes, base mount)

X axis: SS8R (Reversed, Double-slider)

Y axis: SA7R (Reversed) Z axis: SA6R (Reversed)

Model Details

Series: **IK3** — Type: **PBBG1□□D** — Encoder type: **□** — Axis 1 (X axis): **□** — Axis 2 (Y axis): **□** — Axis 3 (Z axis): **□** — Controllers: **B□** — Cable: **P1** — Shipping configuration: **□**

Combination directions 1-2
 Differences between Single-slider and Double-slider Types
 HH: X high-speed, Y high-speed, Z high-speed
 HHM: X high-speed, Y high-speed, Z medium-speed
 HHL: X high-speed, Y high-speed, Z low-speed

Encoder type
 I: Incremental

Stroke (mm)
 S: 50mm
 ? (Can be set in 50-mm increments)

Options
 B: Brake
 NM: Opposite-home specification
 SR: Slider roller specification

Cable length
 1L: 1m
 3L: 3m
 5L: 5m
 □L: □m

Wiring 1
 N: Cable only
 CT: With cable track

Wiring 2
 K: Individual components (kit)

Shipping configuration
 K: Individual components (kit)

* Refer to P. 10 for details on the items comprising the model name.

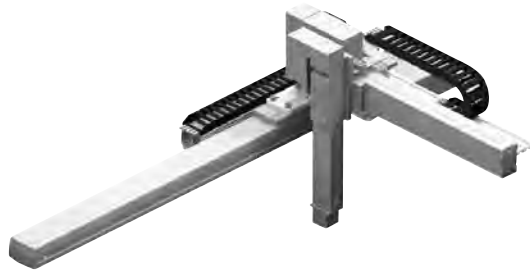

With cable tracks (Wiring 3 does not come with a cable track.)

Maximum Stroke

X axis 800 mm

Y axis 400 mm

Z axis 200 mm

Maximum Speed

	X high-speed, Y high-speed, Z high-speed	X high-speed, Y high-speed, Z medium-speed	X high-speed, Y high-speed, Z low-speed
X axis	220mm/s		
Y axis	420mm/s		
Z axis	500mms	250mm/s	125mm/s

Maximum Load Capacity

Y-axis stroke	X high-speed, Y high-speed, Z high-speed	X high-speed, Y high-speed, Z medium-speed	X high-speed, Y high-speed, Z low-speed
350mm	1.0kg		
400mm	2.0kg		
	4.0kg		

List by Stroke

		Incremental								
		350				400				
Y-axis stroke										
X-axis stroke	Z-axis stroke	50	100	150	200	50	100	150	200	
	50	-	-	-	-	-	-	-	-	-
	100	-	-	-	-	-	-	-	-	-
	150	-	-	-	-	-	-	-	-	-
	200	-	-	-	-	-	-	-	-	-
	250	-	-	-	-	-	-	-	-	-
	300	-	-	-	-	-	-	-	-	-
	350	-	-	-	-	-	-	-	-	-
	400	-	-	-	-	-	-	-	-	-
	450	-	-	-	-	-	-	-	-	-
	500	-	-	-	-	-	-	-	-	-
	550	-	-	-	-	-	-	-	-	-
	600	-	-	-	-	-	-	-	-	-
	650	-	-	-	-	-	-	-	-	-
	700	-	-	-	-	-	-	-	-	-
	750	-	-	-	-	-	-	-	-	-
800	-	-	-	-	-	-	-	-	-	

Cable track

		Y-axis stroke
		350-400
X-axis stroke	50-400	-
	450-600	-
	650-800	-

Note) Both wiring 1 and wiring 2 should have a cable bear, or neither of the two should have a cable track. A cable track cannot be specified for one of the wirings.

List by Cable Length

Type	Cable code	Length
Standard type	1L	1m
	3L	3m
	5L	5m

* Axis 1 comes with a standard cable, while axis 2 comes with a robot cable.

* Refer to P. 90 for lengths other than those specified above.

List by Cable Length

Name	Option code
Opposite-home specification	NM
Slider roller specification	SR

Specifications

Item	X axis	Y axis	Z axis
Axis model	RCP2-SS8R	RCP2-SA7R	RCP2-SA6R
Stroke (Can be set in 50-mm increments)	50-800mm	350-400mm	50-200mm
Max speed	High-speed type: 220mm/s	High-speed type: 420mm/s	High-speed type: 500mm/s Medium-speed type: 250mm/s Low-speed type: 125mm/s
Motor size	56-square pulse motor	56-square pulse motor	42-square pulse motor
Ball screw lead	High-speed type: 20mm	High-speed type: 16mm	High-speed type: 12mm Medium-speed type: 6mm Low-speed type: 3mm
Drive method	Ball screw, ø16mm, rolled, C10	Ball screw, ø12mm, rolled, C10	Ball screw, ø10mm, rolled, C10
Positioning repeatability	±0.02mm		
Base material	Dedicated alloy steel		Aluminum
Surrounding air temperature/humidity	0 to 40°C, 85% RH or below (non-condensing)		

Dimensions

You can download CAD drawings from our website. www.intelligentactuator.com

2D CAD

Note 1. The connected position shown in the drawing defines the home.
 Note 2. The drawing below assumes that both wiring 1 and wiring 2 have a cable track.
 Note 3. For details on the cable track, refer to P. 90.

* Caution

Customer to prepare the parts and attach the X-axis cable track guide rail to the same plane the X-axis actuator is installed.

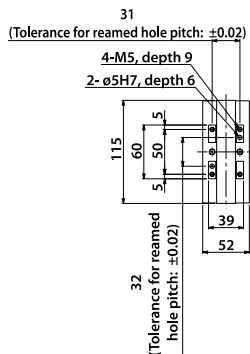
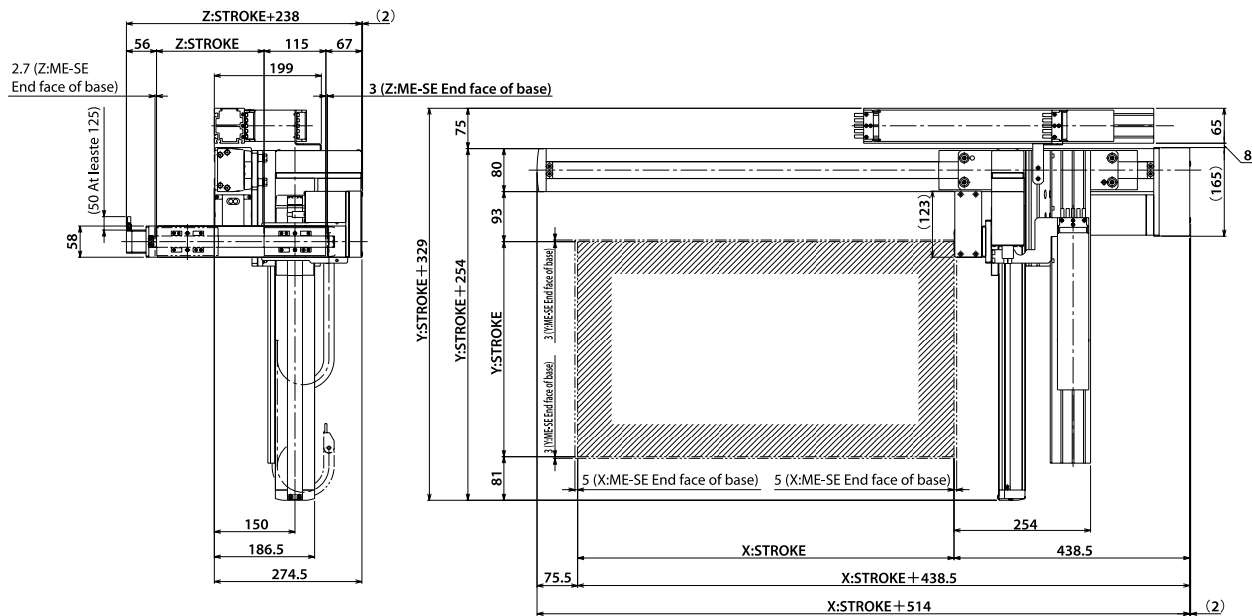

Detail view of Z-axis slider



Detail view of slot in bottom

ME: Mechanical end
 SE: Stroke end

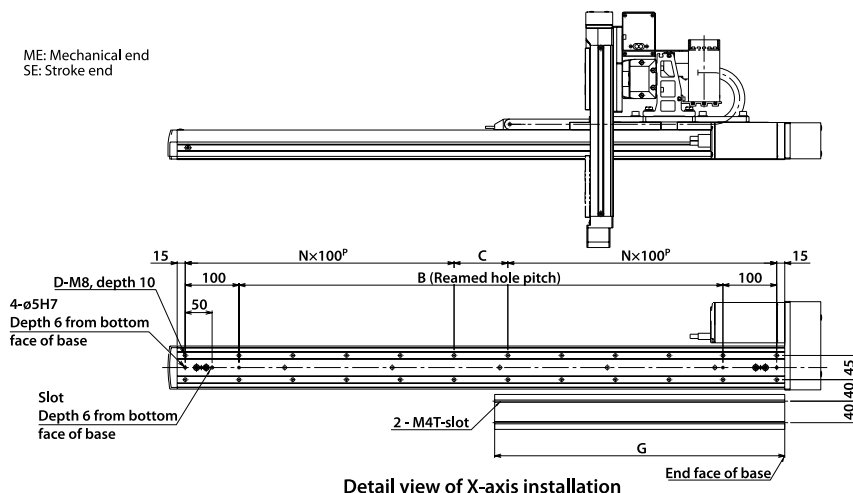

Detail view of X-axis installation

■ Dimensions by Stroke

X: Nominal stroke	250	300	350	400	450	500	550	600	650	700	750	800	850	900	950	1000
X: Effective stroke	50	100	150	200	250	300	350	400	450	500	550	600	650	700	750	800
B	250	300	350	400	450	500	550	600	650	700	750	800	850	900	950	1000
C	50	100	150	0	50	100	150	0	50	100	150	0	50	100	150	0
D	12	12	12	14	16	16	16	18	20	20	20	22	24	24	24	26
N	2	2	2	3	3	3	3	4	4	4	4	5	5	5	5	6
G	214.5	239.5	264.5	289.5	314.5	339.5	364.5	389.5	414.5	439.5	464.5	489.5	514.5	539.5	564.5	589.5

Controllers

Applicable controller

Refer to P. 91 for the controllers.

2-axis Combinations R C P 2
 2-axis Combinations R C S 2
 3-axis Combinations R C P 2
 3-axis Combinations R C S 2
 Controllers

IK3-SBBG1□□S

RCS2 3-axis combination (XYB+Z-axes, base mount)
 X axis: SS8R (100W, Reversed, Single-slider)
 Y axis: SA7R (Reversed) Z axis: SA6R (Reversed)

Model Details Series — Type — Encoder type — Axis 1 (X axis) — Axis 2 (Y axis) — Axis 3 (Z axis) — Controllers — Cable — Shipping configuration

IK3 — **SBBG1**□□**S** — □ — □ — □ — □ — □ — □ — □ — □ — □

Combination directions 1-2
Differences between Single-slider and Double-slider Types
 HHH: X high-speed, Y high-speed, Z high-speed
 HHM: X high-speed, Y high-speed, Z medium-speed
 HHL: X high-speed, Y high-speed, Z low-speed

Encoder type
 I: Incremental
 A: Absolute

Stroke (mm)
 S: 50mm
 ?
 (Can be set in 50-mm increments)

Options
 B: Brake
 NM: Opposite-home specification
 SR: Slider roller specification

Controllers
 T1: XSEL-J/K
 T2: SSEL
 XSEL-P/Q

Cable length
 1L: 1m
 3L: 3m
 5L: 5m
 □L: □m

Wiring 1 N: Cable only
Wiring 2 CT: With cable track

Shipping configuration K: Individual components (kit)

* Refer to P.10 for details on the items comprising the model name.

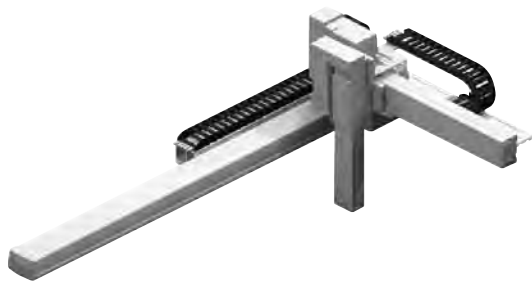

With cable tracks (Wiring 3 does not come with a cable track.)

Maximum Stroke

X axis 1000 mm **Y axis** 300 mm **Z axis** 200 mm

Maximum Speed

	X high-speed, Y high-speed, Z high-speed	X high-speed, Y high-speed, Z medium-speed	X high-speed, Y high-speed, Z low-speed
X axis	1000mm/s		
Y axis	800mm/s		
Z axis	800mm/s	400mm/s	200mm/s

Maximum Load Capacity

Y-axis stroke	X high-speed, Y high-speed, Z high-speed	X high-speed, Y high-speed, Z medium-speed	X high-speed, Y high-speed, Z low-speed
50mm	1.0kg	2.0kg	4.0kg
100mm			
150mm			
200mm			
250mm			
300mm			

List by Stroke

		Incremental											
Y-axis stroke		50				100				150			
Z-axis stroke		50	100	150	200	50	100	150	200	50	100	150	200
X-axis stroke	50	-	-	-	-	-	-	-	-	-	-	-	-
	100	-	-	-	-	-	-	-	-	-	-	-	-
	150	-	-	-	-	-	-	-	-	-	-	-	-
	200	-	-	-	-	-	-	-	-	-	-	-	-
	250	-	-	-	-	-	-	-	-	-	-	-	-
	300	-	-	-	-	-	-	-	-	-	-	-	-
	350	-	-	-	-	-	-	-	-	-	-	-	-
	400	-	-	-	-	-	-	-	-	-	-	-	-
	450	-	-	-	-	-	-	-	-	-	-	-	-
	500	-	-	-	-	-	-	-	-	-	-	-	-
	550	-	-	-	-	-	-	-	-	-	-	-	-
	600	-	-	-	-	-	-	-	-	-	-	-	-
	650	-	-	-	-	-	-	-	-	-	-	-	-
	700	-	-	-	-	-	-	-	-	-	-	-	-
	750	-	-	-	-	-	-	-	-	-	-	-	-
	800	-	-	-	-	-	-	-	-	-	-	-	-
	850	-	-	-	-	-	-	-	-	-	-	-	-
900	-	-	-	-	-	-	-	-	-	-	-	-	
950	-	-	-	-	-	-	-	-	-	-	-	-	
1000	-	-	-	-	-	-	-	-	-	-	-	-	

		Incremental											
Y-axis stroke		200				250				300			
Z-axis stroke		50	100	150	200	50	100	150	200	50	100	150	200
X-axis stroke	50	-	-	-	-	-	-	-	-	-	-	-	-
	100	-	-	-	-	-	-	-	-	-	-	-	-
	150	-	-	-	-	-	-	-	-	-	-	-	-
	200	-	-	-	-	-	-	-	-	-	-	-	-
	250	-	-	-	-	-	-	-	-	-	-	-	-
	300	-	-	-	-	-	-	-	-	-	-	-	-
	350	-	-	-	-	-	-	-	-	-	-	-	-
	400	-	-	-	-	-	-	-	-	-	-	-	-
	450	-	-	-	-	-	-	-	-	-	-	-	-
	500	-	-	-	-	-	-	-	-	-	-	-	-
	550	-	-	-	-	-	-	-	-	-	-	-	-
	600	-	-	-	-	-	-	-	-	-	-	-	-
	650	-	-	-	-	-	-	-	-	-	-	-	-
	700	-	-	-	-	-	-	-	-	-	-	-	-
	750	-	-	-	-	-	-	-	-	-	-	-	-
	800	-	-	-	-	-	-	-	-	-	-	-	-
	850	-	-	-	-	-	-	-	-	-	-	-	-
900	-	-	-	-	-	-	-	-	-	-	-	-	
950	-	-	-	-	-	-	-	-	-	-	-	-	
1000	-	-	-	-	-	-	-	-	-	-	-	-	

		Incremental											
Y-axis stroke	Z-axis stroke	50				100				150			
		50	100	150	200	50	100	150	200	50	100	150	200
X-axis stroke	50	-	-	-	-	-	-	-	-	-	-	-	-
	100	-	-	-	-	-	-	-	-	-	-	-	-
	150	-	-	-	-	-	-	-	-	-	-	-	-
	200	-	-	-	-	-	-	-	-	-	-	-	-
	250	-	-	-	-	-	-	-	-	-	-	-	-
	300	-	-	-	-	-	-	-	-	-	-	-	-
	350	-	-	-	-	-	-	-	-	-	-	-	-
	400	-	-	-	-	-	-	-	-	-	-	-	-
	450	-	-	-	-	-	-	-	-	-	-	-	-
	500	-	-	-	-	-	-	-	-	-	-	-	-
	550	-	-	-	-	-	-	-	-	-	-	-	-
	600	-	-	-	-	-	-	-	-	-	-	-	-
	650	-	-	-	-	-	-	-	-	-	-	-	-
	700	-	-	-	-	-	-	-	-	-	-	-	-
	750	-	-	-	-	-	-	-	-	-	-	-	-
	800	-	-	-	-	-	-	-	-	-	-	-	-
	850	-	-	-	-	-	-	-	-	-	-	-	-
900	-	-	-	-	-	-	-	-	-	-	-	-	
950	-	-	-	-	-	-	-	-	-	-	-	-	
1000	-	-	-	-	-	-	-	-	-	-	-	-	

		Incremental											
Y-axis stroke	Z-axis stroke	200				250				300			
		50	100	150	200	50	100	150	200	50	100	150	200
X-axis stroke	50	-	-	-	-	-	-	-	-	-	-	-	-
	100	-	-	-	-	-	-	-	-	-	-	-	-
	150	-	-	-	-	-	-	-	-	-	-	-	-
	200	-	-	-	-	-	-	-	-	-	-	-	-
	250	-	-	-	-	-	-	-	-	-	-	-	-
	300	-	-	-	-	-	-	-	-	-	-	-	-
	350	-	-	-	-	-	-	-	-	-	-	-	-
	400	-	-	-	-	-	-	-	-	-	-	-	-
	450	-	-	-	-	-	-	-	-	-	-	-	-
	500	-	-	-	-	-	-	-	-	-	-	-	-
	550	-	-	-	-	-	-	-	-	-	-	-	-
	600	-	-	-	-	-	-	-	-	-	-	-	-
	650	-	-	-	-	-	-	-	-	-	-	-	-
	700	-	-	-	-	-	-	-	-	-	-	-	-
	750	-	-	-	-	-	-	-	-	-	-	-	-
	800	-	-	-	-	-	-	-	-	-	-	-	-
	850	-	-	-	-	-	-	-	-	-	-	-	-
900	-	-	-	-	-	-	-	-	-	-	-	-	
950	-	-	-	-	-	-	-	-	-	-	-	-	
1000	-	-	-	-	-	-	-	-	-	-	-	-	

List by Cable Length

Type	Cable code	Length
Standard type	1L	1m
	3L	3m
	5L	5m

* Axis 1 comes with a standard cable, while axis 2 comes with a robot cable.
 * Refer to P. 90 for lengths other than those specified above.

Cable track

		Y-axis stroke	
		50-200	250-300
X-axis stroke	50-400	-	-
	450-600	-	-
	650-800	-	-
	850-1000	-	-

Note) Both wiring 1 and wiring 2 should have a cable bear, or neither of the two should have a cable track. A cable track cannot be specified for one of the wirings.

Options

Name	Option code
Opposite-home specification	NM
Slider roller specification	SR

Specifications

Item	X axis	Y axis	Z axis
Axis model	RCS2-SS8R	RCS2-SA7R	RCS2-SA6R
Stroke (Can be set in 50-mm increments)	50-1000mm	50-300mm	50-200mm
Max speed	High-speed type: 1000mm/s	High-speed type: 800mm/s	High-speed type: 800mm/s Medium-speed type: 400mm/s Low-speed type: 200mm/s
Motor output (W)	100W	60W	30W
Ball screw lead	High-speed type: 20mm	High-speed type: 16mm	High-speed type: 12mm Medium-speed type: 6mm Low-speed type: 3mm
Drive method	Ball screw, ø16mm, rolled, C10	Ball screw, ø12mm, rolled, C10	Ball screw, ø10mm, rolled, C10
Positioning repeatability	±0.02mm		
Base material	Dedicated alloy steel		Aluminum
Surrounding air temperature/humidity	0 to 40°C, 85% RH or below (non-condensing)		

Dimensions

You can download CAD drawings from our website. www.intelligentactuator.com

Note 1. The connected position shown in the drawing defines the home.
 Note 2. The drawing below assumes that both wiring 1 and wiring 2 have a cable track.
 Note 3. For details on the cable track, refer to P. 90.



* Caution

Customer to prepare the parts and attach the X-axis cable track guide rail to the same plane the X-axis actuator is installed.

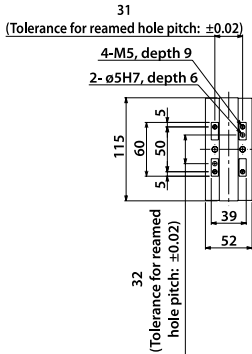
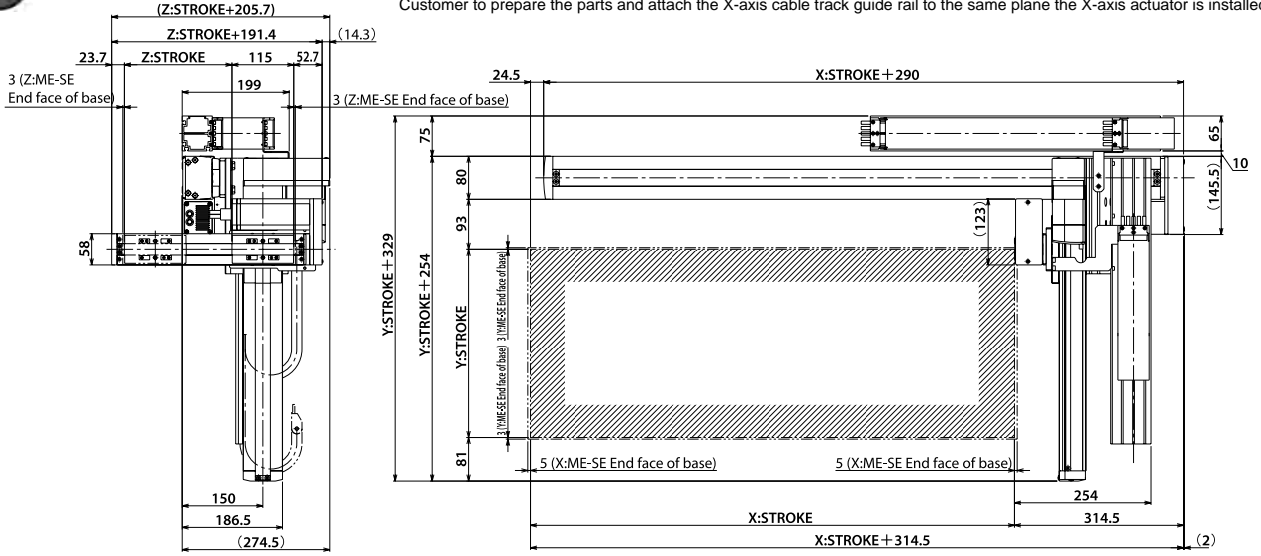

Detail view of Z-axis slider



Detail view of slot in bottom face of X-axis base

ME: Mechanical end
 SE: Stroke end

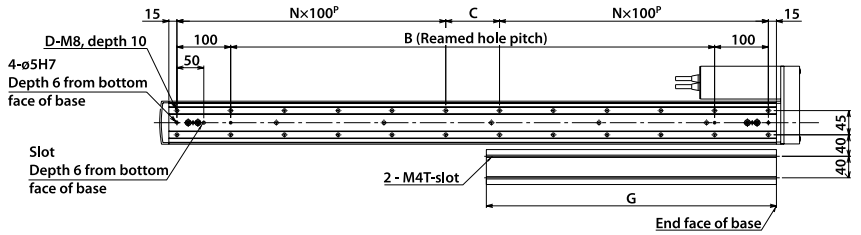
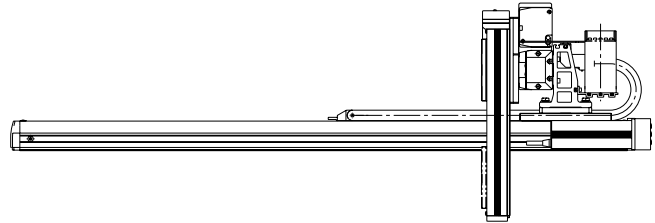

Detail view of X-axis installation

Dimensions by Stroke

X: Model	50	100	150	200	250	300	350	400	450	500	550	600	650	700	750	800	850	900	950	1000
B	50	100	150	200	250	300	350	400	450	500	550	600	650	700	750	800	850	900	950	1000
C	50	100	150	0	50	100	150	0	50	100	150	0	50	100	150	0	50	100	150	0
D	8	8	8	10	12	12	12	14	16	16	16	18	20	20	20	22	24	24	24	26
N	1	1	1	2	2	2	2	3	3	3	3	4	4	4	4	5	5	5	5	6
G	114.5	139.5	164.5	189.5	214.5	239.5	264.5	289.5	314.5	339.5	364.5	389.5	414.5	439.5	464.5	489.5	514.5	539.5	564.5	589.5

Controllers

Applicable controller

Refer to P. 91 for the controllers.

IK3-SBBG1□□D

RCS2 3-axis combination (XYB+Z-axis, base mount)

X axis: SS8R (100W, Reversed, Single-slider)

Y axis: SA7R (Reversed) Z axis: SA6R (Reversed)

Model Details

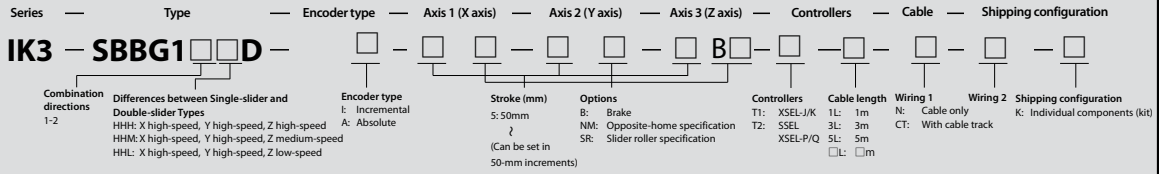

* Refer to P.10 for details on the items comprising the model name.

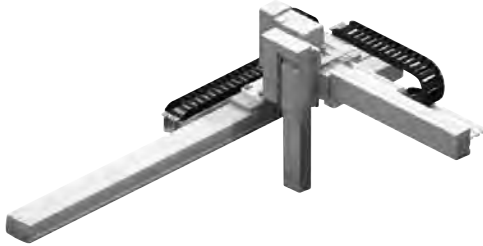

With cable tracks (Wiring 3 does not come with a cable track.)

Maximum Stroke

X axis 800 mm

Y axis 400 mm

Z axis 200 mm

Maximum Speed

	X high-speed, Y high-speed, Z high-speed	X high-speed, Y high-speed, Z medium-speed	X high-speed, Y high-speed, Z low-speed
X axis	1000mm/s		
Y axis	800mm/s		
Z axis	800mm/s	400mm/s	200mm/s

Maximum Load Capacity

Y-axis stroke	X high-speed, Y high-speed, Z high-speed	X high-speed, Y high-speed, Z medium-speed	X high-speed, Y high-speed, Z low-speed
350mm	1.0kg	2.0kg	4.0kg
400mm			

List by Stroke

Y-axis stroke	Incremental								Absolute							
	350				400				350				400			
Z-axis stroke	50	100	150	200	50	100	150	200	50	100	150	200	50	100	150	200
50	-	-	-	-	-	-	-	-	-	-	-	-	-	-	-	-
100	-	-	-	-	-	-	-	-	-	-	-	-	-	-	-	-
150	-	-	-	-	-	-	-	-	-	-	-	-	-	-	-	-
200	-	-	-	-	-	-	-	-	-	-	-	-	-	-	-	-
250	-	-	-	-	-	-	-	-	-	-	-	-	-	-	-	-
300	-	-	-	-	-	-	-	-	-	-	-	-	-	-	-	-
350	-	-	-	-	-	-	-	-	-	-	-	-	-	-	-	-
400	-	-	-	-	-	-	-	-	-	-	-	-	-	-	-	-
450	-	-	-	-	-	-	-	-	-	-	-	-	-	-	-	-
500	-	-	-	-	-	-	-	-	-	-	-	-	-	-	-	-
550	-	-	-	-	-	-	-	-	-	-	-	-	-	-	-	-
600	-	-	-	-	-	-	-	-	-	-	-	-	-	-	-	-
650	-	-	-	-	-	-	-	-	-	-	-	-	-	-	-	-
700	-	-	-	-	-	-	-	-	-	-	-	-	-	-	-	-
750	-	-	-	-	-	-	-	-	-	-	-	-	-	-	-	-
800	-	-	-	-	-	-	-	-	-	-	-	-	-	-	-	-

Cable track

X-axis stroke	Y-axis stroke	
	350-400	400-450
50-400	-	-
450-600	-	-
650-800	-	-

Note) Both wiring 1 and wiring 2 should have a cable bear, or neither of the two should have a cable track. A cable track cannot be specified for one of the wirings.

List by Cable Length

Type	Cable code	Length
Standard type	1L	1m
	3L	3m
	5L	5m

* Axis 1 comes with a standard cable, while axis 2 comes with a robot cable.

* Refer to P.90 for lengths other than those specified above.

List by Cable Length

Name	Option code
Opposite-home specification	NM
Slider roller specification	SR

Specifications

Item	X axis	Y axis	Z axis
Axis model	RCS2-SS8R	RCS2-SA7R	RCS2-SA6R
Stroke (Can be set in 50-mm increments)	50-800mm	350-400mm	50-200mm
Max speed	High-speed type: 1000mm/s	High-speed type: 800mm/s	High-speed type: 800mm/s Medium-speed type: 400mm/s Low-speed type: 200mm/s
Motor output (W)	100W	60W	30W
Ball screw lead	High-speed type: 20mm	High-speed type: 16mm	High-speed type: 12mm Medium-speed type: 6mm Low-speed type: 3mm
Drive method	Ball screw, ϕ 16mm, rolled, C10	Ball screw, ϕ 12mm, rolled, C10	Ball screw, ϕ 10mm, rolled, C10
Positioning repeatability	± 0.02 mm		
Base material	Dedicated alloy steel		Aluminum
Surrounding air temperature/humidity	0 to 40°C, 85% RH or below (non-condensing)		

Dimensions

You can download CAD drawings from our website. www.intelligentactuator.com

Note 1. The connected position shown in the drawing defines the home.
 Note 2. The drawing below assumes that both wiring 1 and wiring 2 have a cable track.
 Note 3. For details on the cable track, refer to P. 90.



* Caution
 Customer to prepare the parts and attach the X-axis cable track guide rail to the same plane the X-axis actuator is installed.

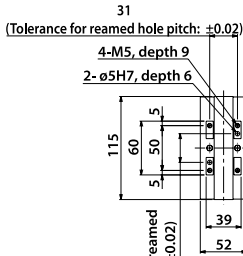
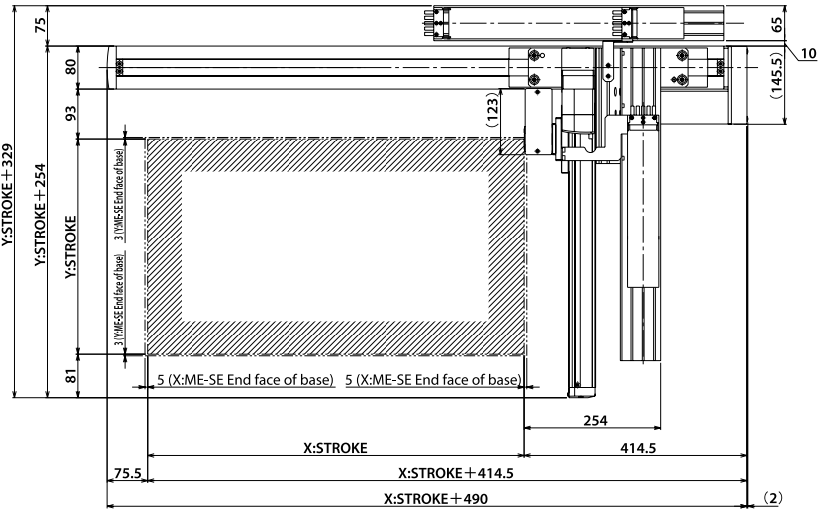
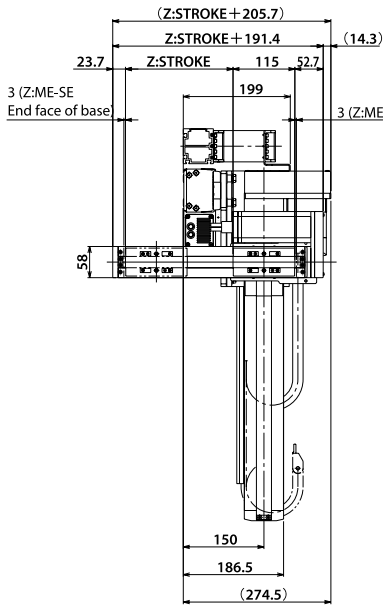

Detail view of Z-axis slider



Detail view of slot in bottom face of X-axis base

ME: Mechanical end
 SE: Stroke end

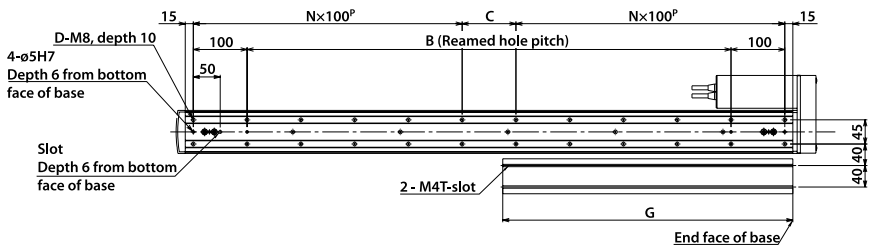
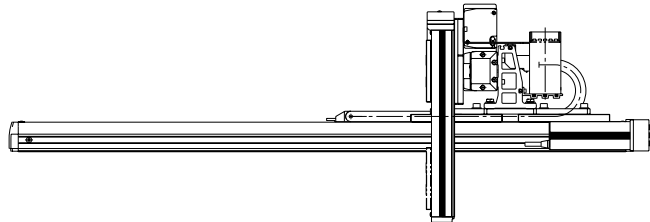

Detail view of X-axis installation

Dimensions by Stroke

X: Nominal stroke	250	300	350	400	450	500	550	600	650	700	750	800	850	900	950	1000
X: Effective stroke	50	100	150	200	250	300	350	400	450	500	550	600	650	700	750	800
B	250	300	350	400	450	500	550	600	650	700	750	800	850	900	950	1000
C	50	100	150	0	50	100	150	0	50	100	150	0	50	100	150	0
D	12	12	12	14	16	16	16	18	20	20	20	22	24	24	24	26
N	2	2	2	3	3	3	3	4	4	4	4	5	5	5	5	6
G	214.5	239.5	264.5	289.5	314.5	339.5	364.5	389.5	414.5	439.5	464.5	489.5	514.5	539.5	564.5	589.5

Controllers

Applicable controller

Refer to P. 91 for the controllers.

Reference

Cable Track

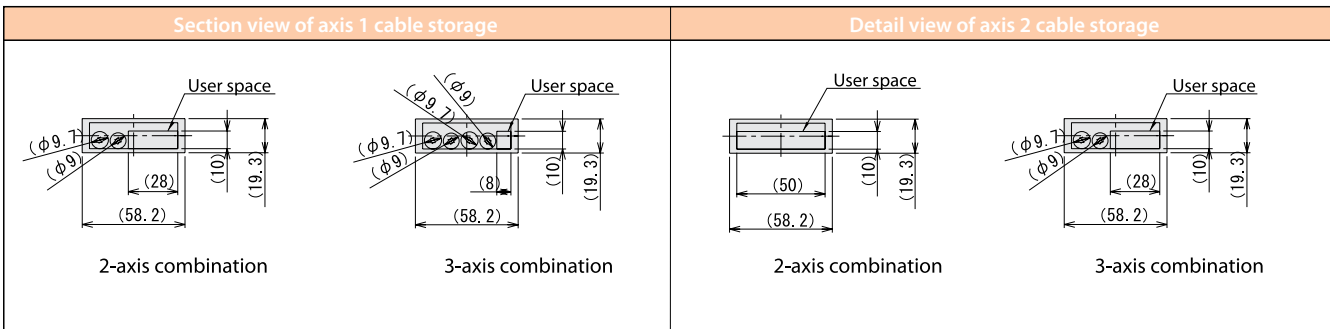

Detail View of Bracket on Moving End of Cable Track

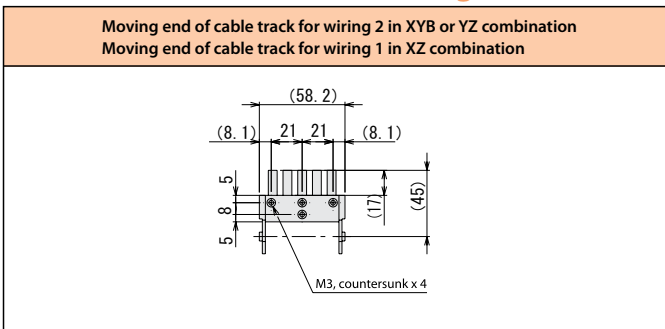

List by Cable Length

Cable code	Length	RCP2 2-axis IK2-P	RCS2 2-axis IK2-S	RCP2 3-axis IK3-P	RCS2 3-axis IK3-S
1L	1m	—	—	—	—
2L	2m	—	—	—	—
3L	3m	—	—	—	—
4L	4m	—	—	—	—
5L	5m	—	—	—	—
6L	6m	—	—	—	—
7L	7m	—	—	—	—
8L	8m	—	—	—	—
9L	9m	—	—	—	—
10L	10m	—	—	—	—
11L	11m	—	—	—	—
12L	12m	—	—	—	—
13L	13m	—	—	—	—
14L	14m	—	—	—	—
15L	15m	—	—	—	—
16L	16m	—	—	—	—
17L	17m	—	—	—	—
18L	18m	—	—	—	—
19L	19m	—	—	—	—
20L	20m	—	—	—	—

* Axis 1 comes with a standard cable, while axes 2 and 3 come with a robot cable.



Controllers

PSEL	RCP2-series program controller	PSEL-C	93
SSEL	RCS2-series program controller	SSEL-C	103
ROBONET	Field network controller	RPCON/RACON/Gateway units	113
XSEL	RCS2-series multi-axis program controller	X-SEL-J / K / P / Q	125

List of Applicable Controllers

	IA kit model	Applicable controller	
2-axis	IK2-PXBD IK2-PXBC	PSEL-C-2-42PI-42PI-NP-2-0	2-axis controller
		PCON-C-42PI-NP-2-0	1-axis controller
		RPCON-42P	1 unit
	IK2-PXBB IK2-PXZB IK2-PYBB	PSEL-C-2-56PI-56PI-NP-2-0	2-axis controller
		PCON-C-56PI-NP-2-0	1-axis controller
		RPCON-56P	1 unit
	IK2-SXBD	SSEL-C-2-60I-20I-NP-2-[1]	2-axis controller (incremental)
		SSEL-C-2-60A-20A-NP-2-[1]	2-axis controller (absolute)
		SCON-C-60I-NP-2-[1]	1-axis controller (incremental for X-axis)
		SCON-C-60A-NP-2-[1]	1-axis controller (absolute for X-axis)
		SCON-C-20I-NP-2-[1]	1-axis controller (incremental for Y-axis)
		SCON-C-20A-NP-2-[1]	1-axis controller (absolute for Y-axis)
	IK2-SXBC	SSEL-C-2-60I-30I-NP-2-[1]	2-axis controller (incremental)
		SSEL-C-2-60A-30A-NP-2-[1]	2-axis controller (absolute)
		SCON-C-60I-NP-2-[1]	1-axis controller (incremental for X-axis)
		SCON-C-60A-NP-2-[1]	1-axis controller (absolute for X-axis)
		SCON-C-30I-NP-2-[1]	1-axis controller (incremental for Y-axis)
		SCON-C-30A-NP-2-[1]	1-axis controller (absolute for Y-axis)
	IK2-SXBB	SSEL-C-2-100I-60I-NP-2-[1]	2-axis controller (incremental)
		SSEL-C-2-100A-60A-NP-2-[1]	2-axis controller (absolute)
		SCON-C-100I-NP-2-[1]	1-axis controller (incremental for X-axis)
		SCON-C-100A-NP-2-[1]	1-axis controller (absolute for X-axis)
		SCON-C-60I-NP-2-[1]	1-axis controller (incremental for Y-axis)
		SCON-C-60A-NP-2-[1]	1-axis controller (absolute for Y-axis)
	IK2-SXBA	SSEL-C-2-150I-100I-NP-2-[1]	2-axis controller (incremental)
		SSEL-C-2-150A-100A-NP-2-[1]	2-axis controller (absolute)
		SCON-C-150I-NP-2-[1]	1-axis controller (incremental for X-axis)
		SCON-C-150A-NP-2-[1]	1-axis controller (absolute for X-axis)
		SCON-C-100I-NP-2-[1]	1-axis controller (incremental for Y-axis)
		SCON-C-100A-NP-2-[1]	1-axis controller (absolute for Y-axis)
	IK2-SXZB	SSEL-C-2-100I-60I-NP-2-[1]	2-axis controller (incremental)
		SSEL-C-2-100A-60A-NP-2-[1]	2-axis controller (absolute)
		SCON-C-100I-NP-2-[1]	1-axis controller (incremental for X-axis)
		SCON-C-100A-NP-2-[1]	1-axis controller (absolute for X-axis)
		SCON-C-60I-NP-2-[1]	1-axis controller (incremental for Z-axis)
		SCON-C-60A-NP-2-[1]	1-axis controller (absolute for Z-axis)
IK2-SYBB	SSEL-C-2-100I-60I-NP-2-[1]	2-axis controller (incremental)	
	SSEL-C-2-100A-60A-NP-2-[1]	2-axis controller (absolute)	
	SCON-C-100I-NP-2-[1]	1-axis controller (incremental for Y-axis)	
	SCON-C-100A-NP-2-[1]	1-axis controller (absolute for Y-axis)	
	SCON-C-60I-NP-2-[1]	1-axis controller (incremental for Z-axis)	
	SCON-C-60A-NP-2-[1]	1-axis controller (absolute for Z-axis)	
3-axis	IK3-PBBG	PSEL-C-2-56PI-42PI-NP-2-0	2-axis controller (for X/Y-axes)
		PCON-C-56PI-NP-2-0	1-axis controller (for X-axis)
		PCON-C-42PI-NP-2-0	1-axis controller (for Y-axis, Z-axis)
		RPCON-56P	1-axis controller (for X-axis)
		RPCON-42P	1-axis controller (for Y-axis, Z-axis)
	IK3-SBBG	SSEL-C-2-100I-60I-NP-2-[1]	2-axis controller (incremental for X/Y-axis)
		SSEL-C-2-100A-60A-NP-2-[1]	2-axis controller (absolute for X/Y-axis)
		SCON-C-100I-NP-2-[1]	1-axis controller (incremental for X-axis)
		SCON-C-100A-NP-2-[1]	1-axis controller (absolute for X-axis)
		SCON-C-60I-NP-2-[1]	1-axis controller (incremental for Y-axis)
		SCON-C-60A-NP-2-[1]	1-axis controller (absolute for Y-axis)
		SCON-C-30I-NP-2-[1]	1-axis controller (incremental for Z-axis)
		SCON-C-30A-NP-2-[1]	1-axis controller (absolute for Z-axis)
		XSEL-J/K/P/Q	Multi-axis controller (incremental or absolute for X/Y/Z-axis)

[1] Power-supply voltage (1: Single-phase 100 VAC / 2: Single-phase 200 VAC)

2-axis Combinations R C P 2
 2-axis Combinations R C S 2
 3-axis Combinations R C P 2
 3-axis Combinations R C S 2
 Controllers
 Model List
 PSEL
 SSEL
 ROBOTNET
 XSEL

2-axis
Combinations
RCP2

2-axis
Combinations
RCS2

3-axis
Combinations
RCP2

3-axis
Combinations
RCS2

Controllers

Model
List

PSEL

SEEL

ROBONET

XSEL



RCP2-series program controller

Model List

A program controller capable of operating RCP2-series actuators. Various controls can be performed with a single unit.

Type	C	
Name	Program mode	Positioner mode
Exterior view		
Description	This controller can operate actuators and communicate with external devices without requiring any additional device. If two axes are operated, arc interpolation and path operation can be performed.	Up to 1,500 positioning points are supported. Push-motion operation and teaching operation are also possible.
Number of positions	1,500	

Model

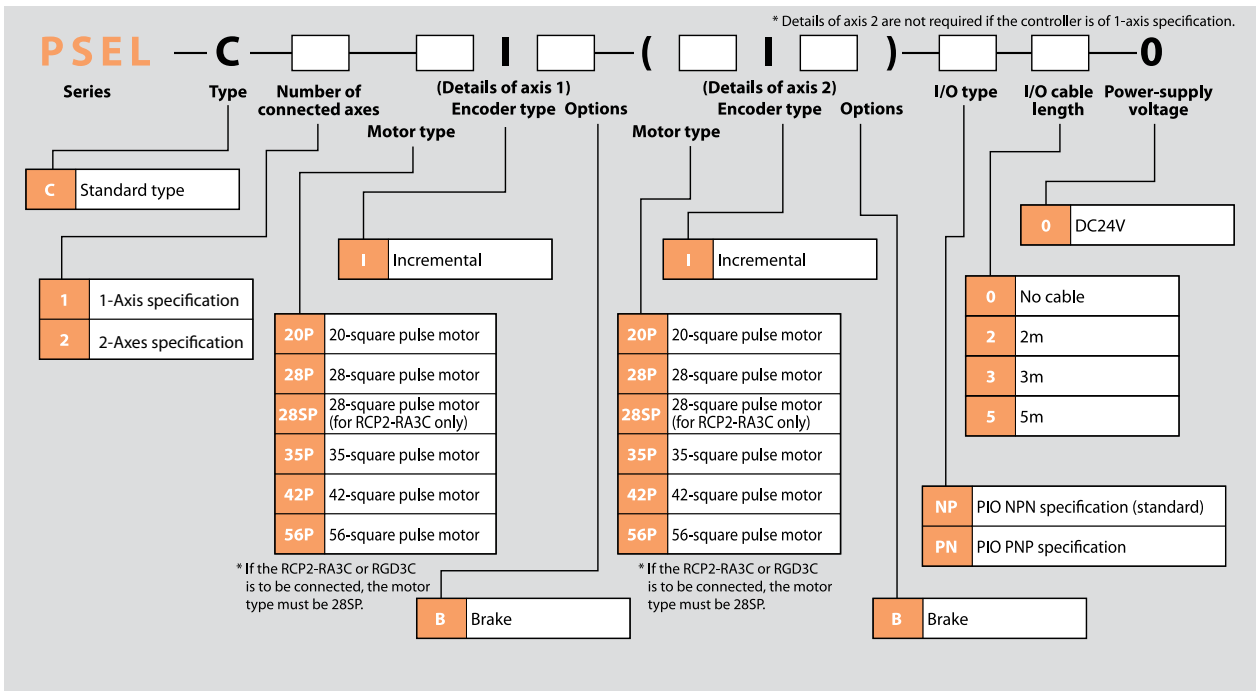

I/O Specifications

Input External input specifications

Item	Specification
Input voltage	DC24V ±10%
Input current	7 mA per circuit
ON/OFF voltages	ON voltage (min.) NPN: DC16V/ PNP: DC8V OFF voltage (max.) NPN: DC5V/ PNP: DC19V
Insulation method	Photo-coupler

NPN specification

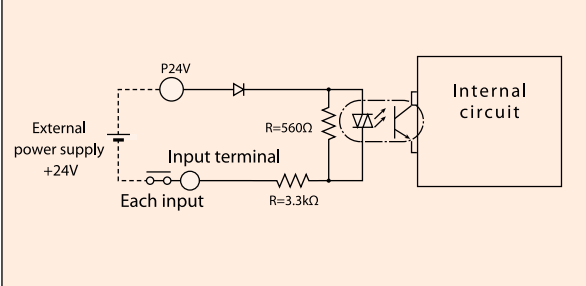

PNP specification

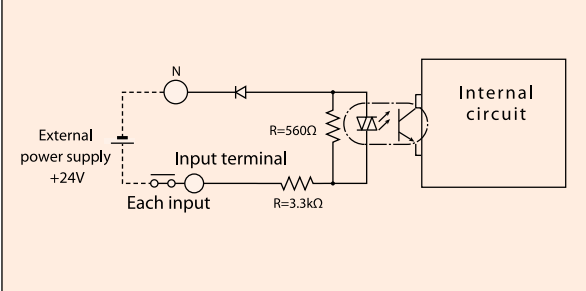

Output External output specifications

Item	Specification
Load voltage	DC24V
Maximum load current	100 mA per point, total 400 mA for 8 points
Leak current (max.)	Max. 0.1 mA per point
Insulation method	Photo-coupler

NPN specification

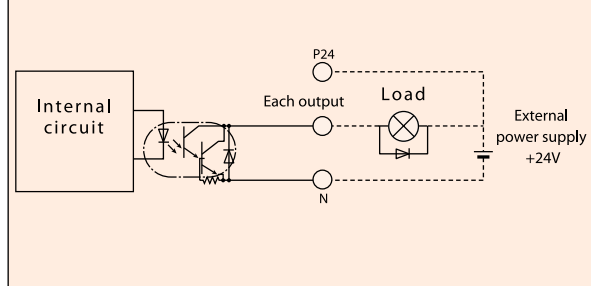

PNP specification

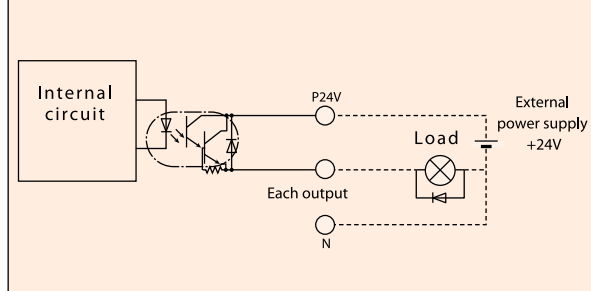

Explanation of I/O Functions

The PSEL controller can be operated in the “Program Mode” where a program is entered to operate the actuator or “Positioner Mode” where the actuator is moved to positions specified by signals received from a host PLC.

The positioner mode includes the following five input patterns to support various applications.

Functions by Controller Type

Operation mode		Features
Program mode		You can use Super SEL, a language that allows for complex controls using simple commands, to perform linear and smooth interpolation operations, path operation ideal for coating and other applications, arch motion and palletizing operations, and more.
Product-type Switchover Mode	Standard mode	The basic operation mode where all you need is to specify a position number and enter a start signal. Push-motion operation, and linear interpolation operation of two axes, is also supported.
	Type switching mode	When the system handles multiple loads of the same shape but slightly different hole positions, you can issue movement commands to the same position number by changing the type number.
	2-axis independent mode	When a 2-axis controller is used, the two axes can be operated independently using separate commands.
	Teaching mode	The slider (rod) can be moved using an external signal to register the stopped position as position data.
	DS-S-C1 compatible mode	If you have been using a DS-S-C1 controller, you can swap it with a PSEL controller without having to change the host programs. * Compatibility with actuators is not assured.

System Configuration

- 2-axis Combinations RCP2
- 2-axis Combinations RCS2
- 3-axis Combinations RCP2
- 3-axis Combinations RCS2
- Controllers
- Model List
- PSEL
- SSEL
- ROBONET
- XSEL

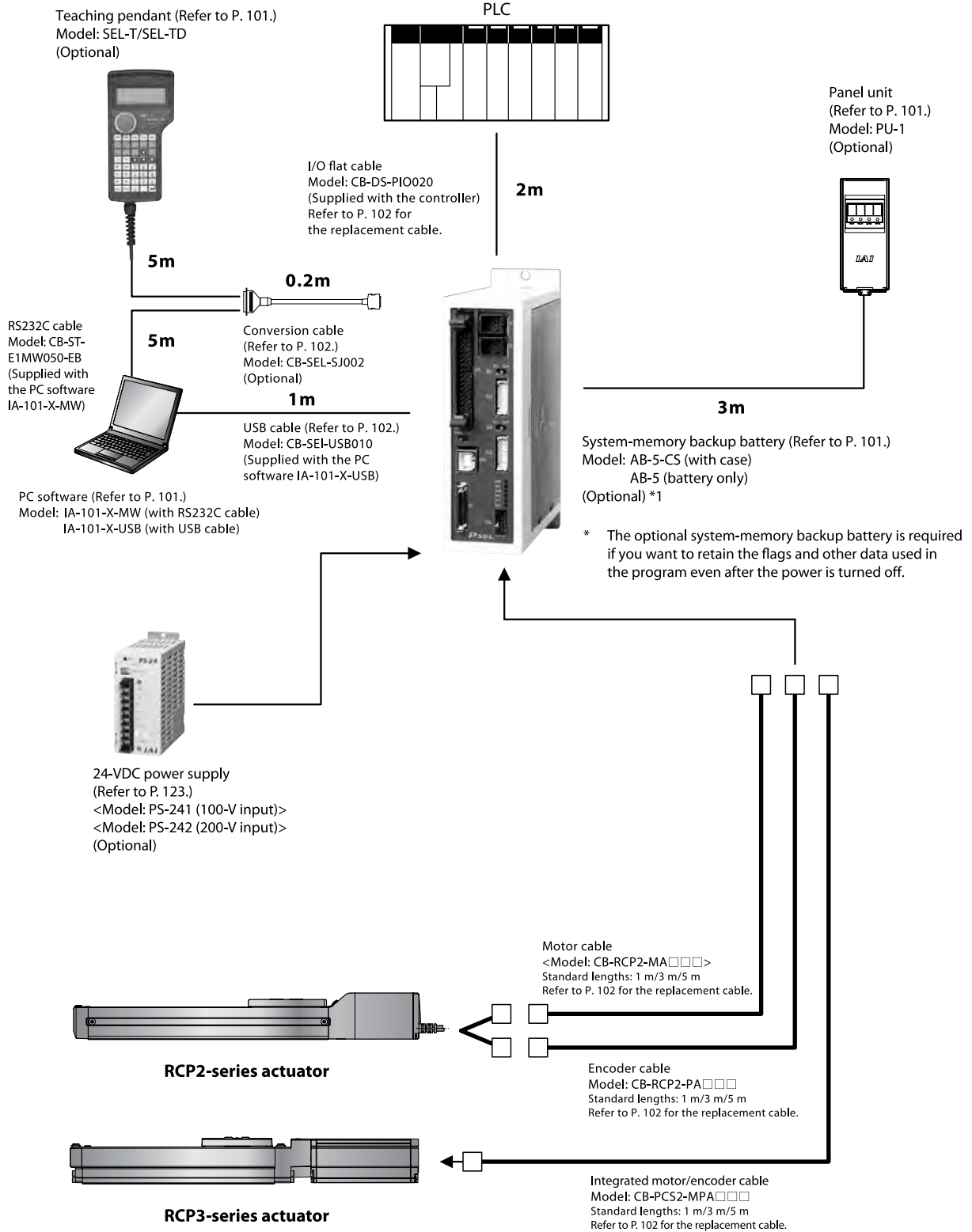

Explanation of I/O Functions

Program Mode

Pin No.	Category	Port No.	Program Mode	Function	Wiring diagram	
1A	P24	016-022	24-V input	Connect 24V.		
1B			Program No. 1 selection	Select the program number of the program you want to start. (Enter one of ports 016 to 022 by a BCD code.)		
2A			Program No. 2 selection			
2B			Program No. 4 selection			
3A			Program No. 8 selection			
3B			Program No. 10 selection			
4A			Program No. 20 selection			
4B			Program No. 40 selection			
5A			023	CPU reset		The system is reset and enters the same state achieved after the power has been reconnected.
5B			000	Start		The program selected by one of port Nos. 016 to 022 is started.
6A			001	General-purpose input		The system waits for an external input in response to a program command.
6B			002	General-purpose input		
7A			003	General-purpose input		
7B			004	General-purpose input		
8A			005	General-purpose input		
8B			006	General-purpose input		
9A			007	General-purpose input		
9B	008	General-purpose input				
10A	009	General-purpose input				
10B	010	General-purpose input				
11A	011	General-purpose input				
11B	012	General-purpose input				
12A	013	General-purpose input				
12B	014	General-purpose input				
13A	015	General-purpose input	These signals can be turned ON/OFF freely using program commands.			
13B	300	Alarm		This signal is output when an alarm has occurred. (Contact B)		
14A	301	Ready		This signal is output when the controller has started properly and become ready to operate.		
14B	302	General-purpose output				
15A	303	General-purpose output				
15B	304	General-purpose output				
16A	305	General-purpose output				
16B	306	General-purpose output				
17A	307	General-purpose output				
17B	N		OV input	Connect OV.		

Positioner, Standard Mode

Pin No.	Category	Port No.	Standard Positioner Mode	Function	Wiring diagram	
1A	P24	016-022	24-V input	Connect 24V.		
1B			Position input 10	Use one of port Nos. 007 to 019 to specify the position number corresponding to the position to move the actuator to. The value can be specified by either a BCD or binary code.		
2A			Position input 11			
2B			Position input 12			
3A			Position input 13			
3B			020			-
4A			021			-
4B			022			-
5A			023	Error reset		This signal resets minor errors. (The power must be reconnected to reset major errors.)
5B			000	Start		The actuator starts moving to the position corresponding to the selected position number.
6A			001	Home return		The actuator returns home.
6B			002	Servo ON		The servo is turned ON/OFF.
7A			003	Push motion		The actuator performs push-motion operation.
7B			004	Pause		The actuator pauses when this signal turns OFF, and resumes the remaining operation when the signal turns ON.
8A			005	Cancel		The actuator stops when this signal turns OFF, and the remaining operation is cancelled.
8B			006	Interpolation setting		In the case of a 2-axis specification, the actuators move via linear interpolation while this signal is ON.
9A			007	Position input 1		Use one of port Nos. 007 to 019 to specify the position number corresponding to the position to move the actuator to. The value can be specified by either a BCD or binary code.
9B	008	Position input 2				
10A	009	Position input 3				
10B	010	Position input 4				
11A	011	Position input 5				
11B	012	Position input 6				
12A	013	Position input 7				
12B	014	Position input 8				
13A	015	Position input 9				
13B	300	Alarm	This signal is output when an alarm has occurred. (Contact B)			
14A	301	Ready	This signal is output when the controller has started properly and become ready to operate.			
14B	302	Positioning complete	This signal is output when movement to the specified position has completed.			
15A	303	Home return complete	This signal is output when home return has completed.			
15B	304	Servo ON output	This signal is output while the servo is ON.			
16A	305	Push-motion complete	This signal is output when push-motion operation has completed.			
16B	306	System battery error	This signal is output when the system battery voltage has dropped (to the warning level).			
17A	307	-	-			
17B	N		OV input	Connect OV.		

2-axis Combinations RCP2

2-axis Combinations RCS2

3-axis Combinations RCP2

3-axis Combinations RCS2

Controllers

Model List

PSEL

SSEL

ROBONET

XSEL

Explanation of I/O Functions

Positioner, Product-Type Switchover Mode

Pin No.	Category	Port No.	Type-switching Positioner Mode	Function				
1A	P24	016	24-V input	Connect 24V.				
1B			Position/type input 10	Use one of port Nos. 007 to 022 to specify the position number corresponding to the position to move the actuator to, and another to specify the type number. Assignment of position numbers and type numbers are set using parameters. The value can be specified by either a BCD or binary code.				
2A			Position/type input 11					
2B			Position/type input 12					
3A			Position/type input 13					
3B			Position/type input 14					
4A			Position/type input 15					
4B			Position/type input 16					
5A			023		Error reset	This signal resets minor errors. (The power must be reconnected to reset major errors.)		
5B			000		Start	The actuator starts moving to the position corresponding to the selected position number.		
6A			001		Home return	The actuator returns home.		
6B			002		Servo ON	The servo is turned ON/OFF.		
7A			Input		003	Push motion	The actuator performs push-motion operation.	
7B						004	Pause	The actuator pauses when this signal turns OFF, and resumes the remaining operation when the signal turns ON.
8A						005	Cancel	The actuator stops when this signal turns OFF, and the remaining operation is cancelled.
8B						006	Interpolation setting	In the case of a 2-axis specification, the actuators move via linear interpolation while this signal is ON.
9A	007	Position/type input 1				Use one of port Nos. 007 to 022 to specify the position number corresponding to the position to move the actuator to, and another to specify the type number. Assignment of position numbers and type numbers are set using parameters. The value can be specified by either a BCD or binary code.		
9B	008	Position/type input 2						
10A	009	Position/type input 3						
10B	010	Position/type input 4						
11A	011	Position/type input 5						
11B	012	Position/type input 6						
12A	013	Position/type input 7						
12B	014	Position/type input 8						
13A	015	Position/type input 9						
13B	Output	300	Alarm	This signal is output when an alarm has occurred. (Contact B)				
14A			301	Ready	This signal is output when the controller has started properly and become ready to operate.			
14B			302	Positioning complete	This signal is output when movement to the specified position has completed.			
15A			303	Home return complete	This signal is output when home return has completed.			
15B			304	Servo ON output	This signal is output while the servo is ON.			
16A			305	Push-motion complete	This signal is output when push-motion operation has completed.			
16B			306	System battery error	This signal is output when the system battery voltage has dropped (to the warning level).			
17A			307	-	-			
17B	N	-	OV input	Connect OV.				

Wiring diagram

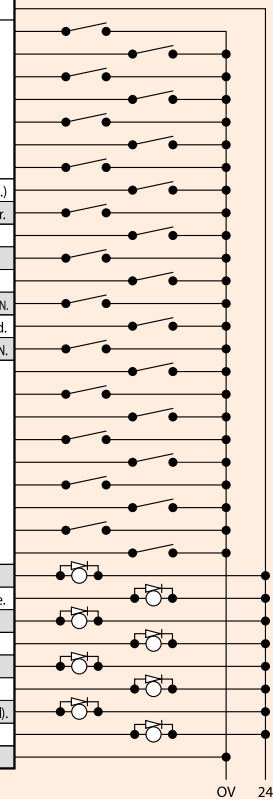

Positioner, 2-axes Independent Mode

Pin No.	Category	Port No.	Type-switching Positioner Mode	Function				
1A	P24	016	24-V input	Connect 24V.				
1B			Position input 7	Use any of port Nos. 010 to 022 to specify the position number corresponding to the position to move the actuator to. Assignment of position numbers for axes 1 and 2 are set using parameters. The value can be specified by either a BCD or binary code.				
2A			Position input 8					
2B			Position input 9					
3A			Position input 10					
3B			Position input 11					
4A			Position input 12					
4B			Position input 13					
5A			023		Error reset	This signal resets minor errors. (The power must be reconnected to reset major errors.)		
5B			000		Start 1	Axis 1 starts moving to the selected position number.		
6A			001		Home return 1	Axis 1 returns home.		
6B			002		Servo ON 1	The servo of axis 1 is turned ON/OFF.		
7A			Input		003	Pause 1	Axis 1 pauses when this signal turns OFF, and resumes the remaining operation when the signal turns ON.	
7B						004	Cancel 1	Movement of axis 1 is cancelled.
8A						005	Start 2	Axis 2 starts moving to the selected position number.
8B						006	Home return 2	Axis 2 returns home.
9A	007	Servo ON 2				The servo of axis 2 is turned ON/OFF.		
9B	008	Pause 2		Axis 2 pauses when this signal turns OFF, and resumes the remaining operation when the signal turns ON.				
10A	009	Cancel 2		Movement of axis 2 is cancelled.				
10B	010	Position input 1		Use any of port Nos. 010 to 022 to specify the position number corresponding to the position to move the actuator to. Assignment of position numbers for axes 1 and 2 are set using parameters. The value can be specified by either a BCD or binary code.				
11A	011	Position input 2						
11B	012	Position input 3						
12A	013	Position input 4						
12B	014	Position input 5						
13A	015	Position input 6						
13B	Output	300	Alarm		This signal is output when an alarm has occurred. (Contact B)			
14A			301		Ready	This signal is output when the controller has started properly and become ready to operate.		
14B			302		Positioning complete 1	This signal is output when movement of axis 1 to the specified position has completed.		
15A			303	Home return complete 1	This signal is output when home return of axis 1 has completed.			
15B			304	Servo ON output 1	This signal is output while the servo of axis 1 is ON.			
16A			305	Positioning complete 2	This signal is output when movement of axis 2 to the specified position has completed.			
16B			306	Home return complete 2	This signal is output when home return of axis 2 has completed.			
17A			307	Servo ON output 2	This signal is output while the servo of axis 2 is ON.			
17B	N	-	OV input	Connect OV.				

Wiring diagram

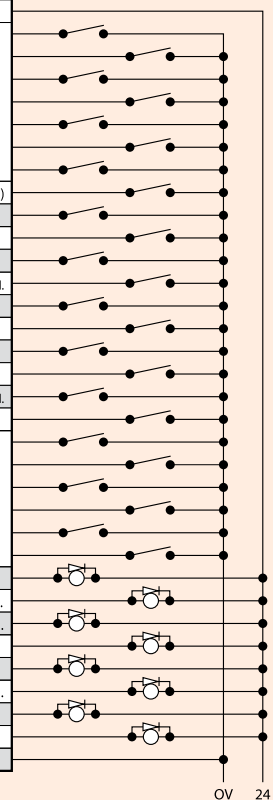

Explanation of I/O Functions

Positioner, Teach Mode

Pin No.	Category	Port No.	Type-switching Positioner Mode	Function	Wiring diagram		
1A	P24	016	24-V input	Connect 24V.			
1B			Axis 1 JOG -	Axis 1 moves in the negative direction while this signal is input.			
2A			Axis 2 JOG +	Axis 2 moves in the positive direction while this signal is input.			
2B			Axis 2 JOG -	Axis 2 moves in the negative direction while this signal is input.			
3A			019	Inching specification (0.01 mm)		Specify the travel over which to move the actuator by inching. (The travel is the sum of values specified by port Nos. 019 to 022.)	
3B			020	Inching specification (0.1 mm)			
4A			021	Inching specification (0.5 mm)			
4B			022	Inching specification (1 mm)			
5A			023	Error reset		This signal resets minor errors. (The power must be reconnected to reset major errors.)	
5B			000	Start		The actuator starts moving to the position corresponding to the selected position number.	
6A			001	Servo ON		The servo is turned ON/OFF.	
6B			002	Pause		The actuator pauses when this signal turns OFF, and resumes the remaining operation when the signal turns ON.	
7A			Input	003		Position input 1	Use one of port Nos. 003 to 013 to specify the position number corresponding to the position to move the actuator to, and another to specify the position number under which to input the current position. If port No. 014 for teaching mode specification is ON, the current value is written to the specified position number when port No. 000 for start signal turns ON.
7B				004		Position input 2	
8A				005		Position input 3	
8B				006		Position input 4	
9A				007		Position input 5	
9B	008	Position input 6					
10A	009	Position input 7					
10B	010	Position input 8					
11A	011	Position input 9					
11B	012	Position input 10					
12A	013	Position input 11					
12B	014	Teaching mode specification					
13A	015	Axis 1 JOG +	Axis 1 moves in the positive direction while this signal is input.				
13B	300	Alarm	This signal is output when an alarm has occurred. (Contact B)				
14A	301	Ready	This signal is output when the controller has started properly and become ready to operate.				
14B	302	Positioning complete	This signal is output when movement to the specified position has completed.				
15A	303	Home return complete	This signal is output when home return has completed.				
15B	304	Servo ON output	This signal is output while the servo is ON.				
16A	305	-	-				
16B	306	System battery error	This signal is output when the system battery voltage has dropped (to the warning level).				
17A	307	-	-				
17B	N	-	OV input	Connect OV.			

Positioner, DS-S-C1 Compatible Mode

Pin No.	Category	Port No.	Standard Positioner Mode	Function	Wiring diagram		
1A	P24	016	24-V input	Connect 24V.			
1B			Position No. 1000	(Same with port Nos. 004 to 015.)			
2A			017	-		-	
2B			018	-		-	
3A			019	-		-	
3B			020	-		-	
4A			021	-		-	
4B			022	-		-	
5A			023	CPU reset		The system is reset and enters the same state achieved after the power has been reconnected.	
5B			000	Start		The actuator starts moving to the position corresponding to the selected position number.	
6A			001	Hold (pause)		The actuator pauses when this signal turns ON, and resumes the remaining operation when the signal turns OFF.	
6B			002	Cancel		The actuator stops when this signal turns ON, and the remaining operation is cancelled.	
7A			Input	003		Interpolation setting	In the case of a 2-axis specification, the actuators move via linear interpolation while this signal is ON. Use one of port Nos. 004 to 016 to specify the position number corresponding to the position to move the actuator to. The value is specified by a BCD code.
7B				004		Position No. 1	
8A				005		Position No. 2	
8B				006		Position No. 4	
9A				007		Position No. 8	
9B	008	Position No. 10					
10A	009	Position No. 20					
10B	010	Position No. 40					
11A	011	Position No. 80					
11B	012	Position No. 100					
12A	013	Position No. 200					
12B	014	Position No. 400					
13A	015	Position No. 800					
13B	300	Alarm	This signal is output when an alarm has occurred. (Contact A)				
14A	301	Ready	This signal is output when the controller has started properly and become ready to operate.				
14B	302	Positioning complete	This signal is output when movement to the specified position has completed.				
15A	303	-	-				
15B	304	-	-				
16A	305	-	-				
16B	306	System battery error	This signal is output when the system battery voltage has dropped (to the warning level).				
17A	307	-	-				
17B	N	-	OV input	Connect OV.			

2-axis Combinations R C P 2

2-axis Combinations R C S 2

3-axis Combinations R C P 2

3-axis Combinations R C S 2

Controllers

Model List

PSEL

SSEL

ROBONET

XSEL

Specification Table

	Item	Specification
Base specifications	Connected actuator	RCP2-series actuator (Note 1)
	Input voltage	24 VDC ±10%
	Power-supply capacity	Max. 5.5 A
	Dielectric strength	500 VDC, 10 MΩ or more
	Withstand voltage	500 VAC, 1 minute
	Rush current	Max. 30 A
	Vibration resistance	XYZ directions: 10 to 57 Hz: (Single amplitude) 0.035 mm (continuous), 0.0 75 mm (intermittent) 58 to 150 Hz: 4.9 m/sec ² (continuous), 9.8 m/sec ² (intermittent)
Control specifications	Number of controlled axes	1/2
	Maximum total output of connected axes	-
	Position detection method	Incremental encoder
	Speed setting	1 mm/sec ~ (The maximum limit varies depending on the actuator.)
	Acceleration setting	0.01 G ~ (The maximum limit varies depending on the actuator.)
	Operation method	Program operation/positioner operation (switchable)
Program	Program language	Super SEL
	Number of programs	64
	Number of program steps	2,000
	Number of multi-tasking programs	8
	Number of positioning points	1500
	Data storage device	Flash ROM (An optional system-memory backup battery can be added.)
Communication related	Data input method	Teaching pendant or PC software
	Number of I/O points	24 input points/8 output points (NPN/PNP selectable)
	I/O power supply	24 VDC ±10%, externally supplied
	PIO cable	CB-DS-PIO□□□ (supplied with the controller)
	Serial communication function	RS232C (half-pitch connector)/USB connector
	Field network cable	(To be supported in the future)
	Motor cable	CB-RCP2-MA□□□ (max. 20 m)
	Encoder cable	CB-RCP2-PA□□□ (max. 20 m)
General specifications	Protective functions	Motor/driver temperature check, encoder open check, soft limit overtravel, system error, battery error, etc.
	Surrounding air temperature/humidity	0 to 40°C, 10 to 95% (non-condensing)
	Surrounding ambience	Free from corrosive gases or significant dust.
	Protection degree	IP20
	Weight	Approx. 450 g
External dimensions	43 mm (W) x 159 mm (H) x 110 mm (D)	

The high-thrust type (RA10C), high-speed type (HS8C/HS8R) and waterproof type (RCP2W-SA16) are not operated.

External Dimensions

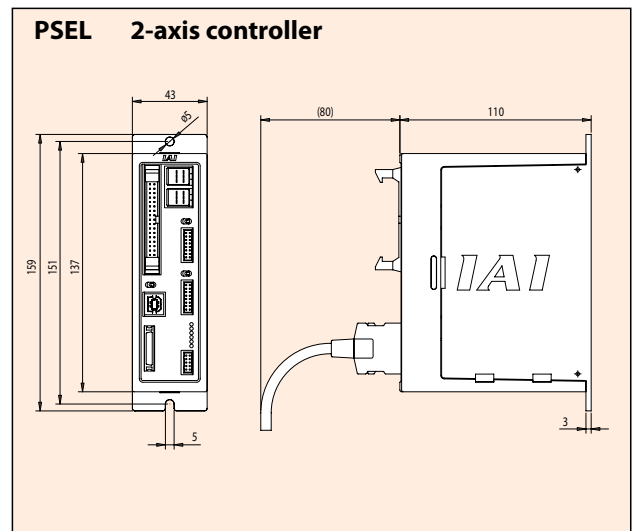
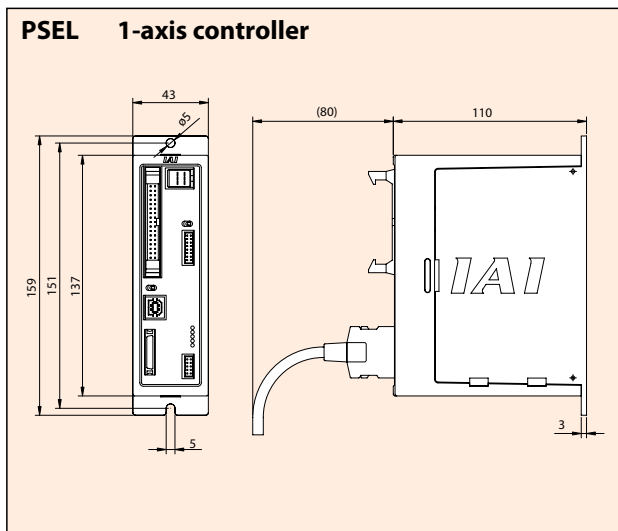

Name of Each part

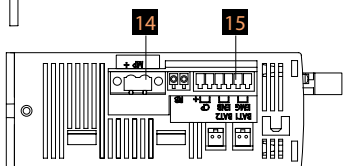
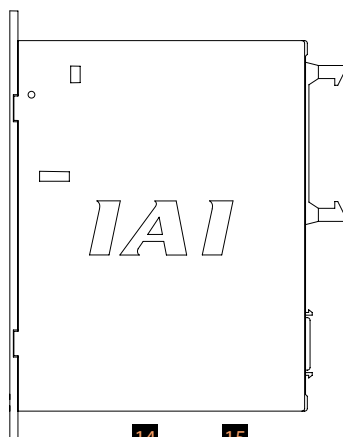
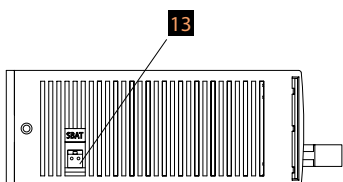
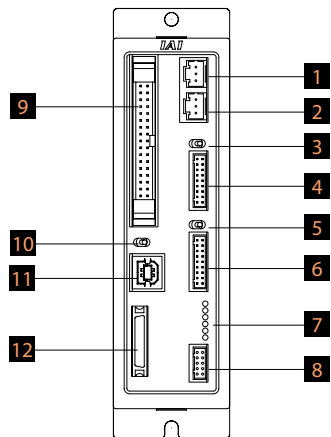

1 Axis 1 motor connector

Connect the motor cable for actuator axis 1 here.

2 Axis 2 motor connector

Connect the motor cable for actuator axis 2 here.

3 Axis 1 brake switch

This switch is used to release the axis brake. When the switch is set to the left (RLS) position, the brake is forcibly released. When the switch is set to the right (NOM) position, the brake is controlled automatically by the controller.

4 Axis 1 encoder connector

Connect the encoder cable for actuator axis 1 here.

5 Axis 2 brake switch

This switch is used to release the axis brake. When the switch is set to the left (RLS) position, the brake is forcibly released. When the switch is set to the right (NOM) position, the brake is controlled automatically by the controller.

6 Axis 2 encoder connector

Connect the encoder cable for actuator axis 2 here.

7 Status indicator LEDs

These LEDs indicate the operating status of the controller. What is indicated by each LED is explained below:

PWR: The power is currently input to the controller.

RDY: The controller is ready to perform program operation.

ALM: The controller is abnormal.

EMG: An emergency stop has been actuated and the drive source is being cut off.

SV1: The servo of actuator axis 1 is turned ON.

SV2: The servo of actuator axis 2 is turned ON.

8 Panel unit connector

This connector is used to connect the panel unit (optional) for displaying the controller status and error numbers.

9 IO connector

A connector for interface IOs.

If a DIO (24IN/8OUT) interface is used, this connector accepts a 34-pin flat cable connector.

The IO power is also supplied to the controller through this connector (pins 1 and 34).

10 Mode switch

This switch is used to indicate the operation mode of the controller.

The left position indicates the MANU (manual operation) mode, while the right position indicates the AUTO (auto operation) mode. Teaching operation can only be performed in the MANU mode, and operation using external IOs cannot be performed in the MANU mode.

11 USB connector

This connector is used to make USB connection with a PC. When the USB connector is in use, the TP connector cannot be used because communication through the TP connector is cut off.

12 Teaching pendant connector

This half-pitch, IO26-pin connector is used to connect a teaching pendant when the operation mode is MANU. You need a dedicated conversion cable to connect to a conventional D-sub, 25-pin connector.

13 System-memory backup battery connector

This connector is used to connect the battery needed to retain the various data stored in the built-in SRAM of the controller even after the power is cut off. The system-memory backup battery is installed on the exterior of the unit. This battery is not a standard accessory (available as an option).

14 Motor-power input connector

This connector is used to input the motor power and consists of a 2-pin, 2-piece connector by Phoenix Contact.

15 Control-power/system input connector

This connector is used to connect the controller power input, emergency stop switch and enable switch, and consists of a 6-pin, 2-piece connector by Phoenix Contact.

2-axis Combinations R C P 2

2-axis Combinations R C S 2

3-axis Combinations R C P 2

3-axis Combinations R C S 2

Controllers

Model List

PSEL

SSEL

ROBONET

XSEL

Options

Teaching Pendant

Features A teaching device offering functions for program/position input, test operation, monitoring, and more.

Model/Price

Model	Description
SEL-T-J	Standard type with connector conversion cable
SEL-TD-J	Deadman switch type with connector conversion cable

Configuration

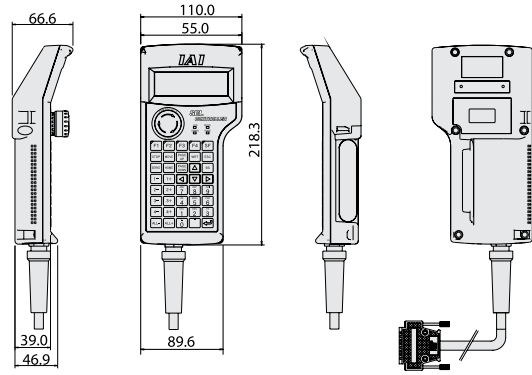
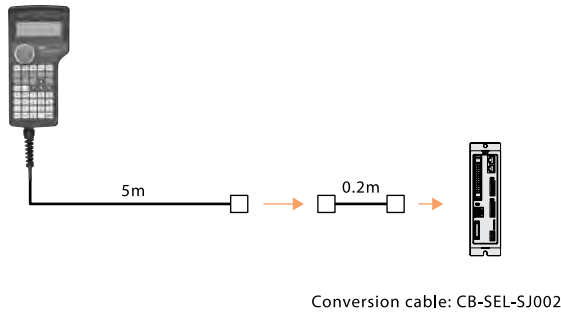

Specification

Item	SEL-T-J	SEL-TD-J
3-position enable switch	Not equipped	Equipped
ANSI/UL standard	Not compliant	Compliant
CE mark	Compliant	
Display	20 characters x 4 lines	
Surrounding air temperature/humidity	0-40°C 10-90%RH (non-condensing)	
Protection structure	IP54	
Weight	Approx. 0.4 kg (excluding cables)	

PC Software (Windows only)

Features A software program that assists the initial startup of your system, offering functions for program/position input, test operation, monitoring, and more. The enhanced debugging functions help reduce the startup time.

Model IA-101-X-MW-J (with RS232C cable + connector conversion cable)

Configuration

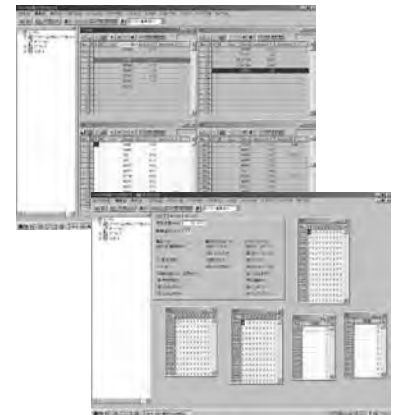
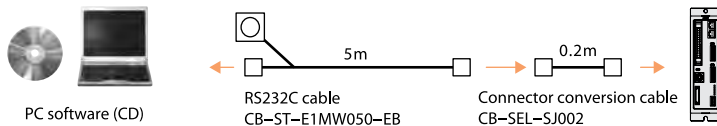

Note
The PSEL controller only supports version 7.0.0.0 or later.

Model IA-101-X-USB (with USB cable)

Configuration

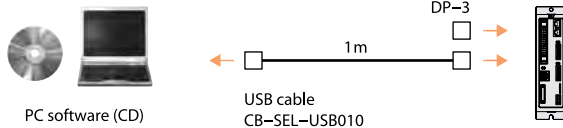

Panel Unit

Features A display for checking controller error codes and the program number of the current program.

Model PU-1 (cable length: 3 m)

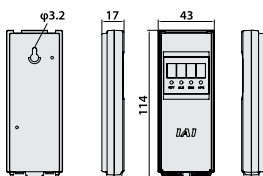

System memory backup battery

Features This battery is needed when global flags, etc., are used in the program and you want the data to be retained even after the power is turned off.

Model AB-5-CS (with case)
AB-5 (battery)



Dummy plug

Features This plug is connected to the teaching pendant to cut off the enable circuit when connecting the PSEL controller to a PC via a USB cable. (This plug is supplied with the PC software IA-101-X-USB.)

Model DP-3



2-axis Combinations RCP2
2-axis Combinations RCS2
3-axis Combinations RCP2
3-axis Combinations RCS2
Controllers
Model List
PSEL
SEEL
ROBONET
XSEL

Options

USB cable

Features This cable is used to connect a controller with USB port to a PC.
To connect a controller without USB port (XSEL) to a PC, connect the controller's RS232C cable to a USB cable via a USB conversion adapter and connect the USB cable to the USB port on the PC.
(Refer to the PC software IA-101-X-USBMW.)

Model **CB-SEL-USB010** (cable length: 1 m)



Connector conversion cable

Features This conversion cable is used to connect the D-sub, 25-pin connector for teaching pendant or PC to the teaching connector (half-pitch) on the PSEL controller.

Model **CB-SEL-SJ002** (cable length: 0.2 m)



Replacement Parts

If you must order a replacement cable, etc., after the initial purchase of your product, specify the correct model by referring to the information below.

Motor Cable

Item **CB-RCP2-MA** [] [] [] * The standard motor cable is a robot cable.

* [] [] [] indicates the cable length (L). A desired length up to 20 m can be specified. Example) 080 = 8 m

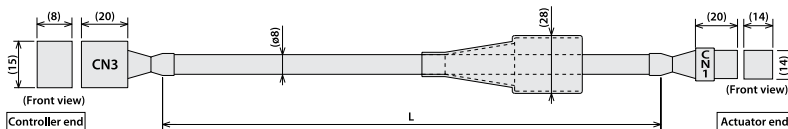

CN3			M cable			CN1			
Orange	A	A1	1	A	Yellow	1	A	Yellow	SLP-06V (JST)
Gray	VMM	A2	2	VMM	Gray	2	A	Gray	
White	B	A3	3	A	Orange	3	A	Orange	
Yellow	A	B1	4	B	Orange/Black	4	B	Orange/Black	
Pink	VMM	B2	5	VMM	Pink	5	B	Pink	
Orange/Black	B	B3	6	B	White	6	B	White	

Encoder Cable/Robot Encoder Cable

Item **CB-RCP2-PB** [] [] [] / **CB-RCP2-PB** [] [] [] -**RB** * The standard encoder cable is a normal cable.
A robot cable can be specified as an option.

* [] [] [] indicates the cable length (L). A desired length up to 20 m can be specified. Example) 080 = 8 m

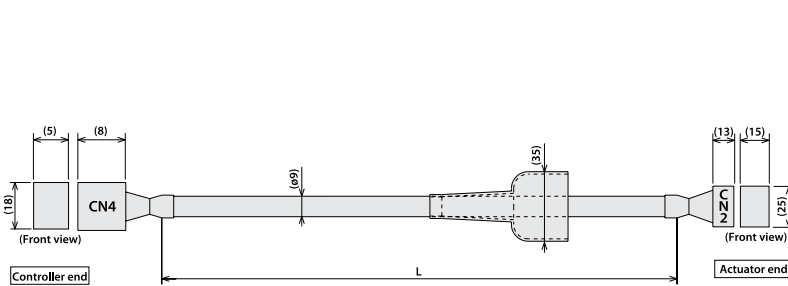

CN4			Signal name			Pin name			CN2		
Blue (red 1)	LS+	16	LS+	16	Blue (red 1)	9	GND	Blue (red 1)	9	GND	9
White	LS-	15	LS-	15	White	10	VBB	White (red 1)	10	VBB	10
Red	BK+	14	BK+	14	Red	11	VPS	Red (red 1)	11	VPS	11
Gray	BK-	13	BK-	13	Gray	12	(N.C.)	Gray (red 1)	12	(N.C.)	12
Brown	ENA	12	ENA	12	Brown	13	LS+	Brown (red 1)	13	LS+	13
Green	ENA	11	ENA	11	Green	14	LS-	Green (red 1)	14	LS-	14
Purple	ENB	10	ENB	10	Purple	15	BK+	Purple (red 1)	15	BK+	15
Pink	ENB	9	ENB	9	Pink	16	BK-	Pink (red 1)	16	BK-	16
Yellow	VPS	7	VPS	7	Yellow	17	BK-	Yellow (red 1)	17	BK-	17
Orange	VBB	6	VBB	6	Orange	18	F.G	Orange (red 1)	18	F.G	18
Blue	GND	5	GND	5	Blue			Blue (red 1)			
(N.C.)	(N.C.)	4	(N.C.)	4	(N.C.)			(N.C.)			
(N.C.)	(N.C.)	3	(N.C.)	3	(N.C.)			(N.C.)			
(N.C.)	(N.C.)	2	(N.C.)	2	(N.C.)			(N.C.)			
Ground	F.G	1	F.G	1	Ground			Ground			

Integrated Motor/Encoder Cable for RCP3

Item **CB-PCS-MPA** [] [] []

* [] [] [] indicates the cable length (L). A desired length up to 10 m can be specified. Example) 080 = 8 m

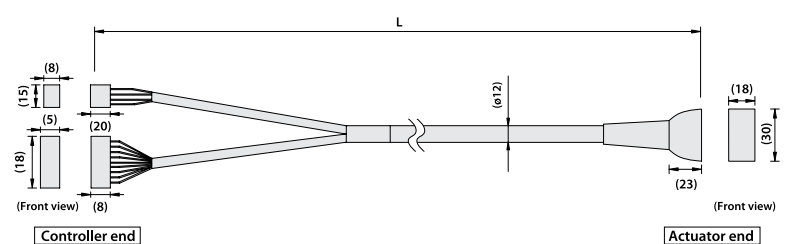

Signal	Pin No.	(Wire color)	Pin No.	Signal
A	B1	Black	B1	VMM
VMM	A2	White	A2	A
/A	A1	Red	B2	B
B	B3	Green	B3	VMM
VMM	B2	Yellow	B3	/B
/B	A3	Brown	A4	NC
			B4	NC
BK+	14	Pink (Red.)	A5	BK+
BK-	13	Pink (Blue.)	B5	BK-
LS+	16	White (Red.)	A6	LS+
LS-	15	White (Blue.)	B6	LS-
A+	12	Orange (Red.)	A7	A+
A-	11	Orange (Blue.)	B7	A-
B+	10	Gray (Red.)	A8	B+
B-	9	Gray (Blue.)	B8	B-
NC	8		A9	NC
VPS	7	Orange (Blue continuous)	B9	VPS
VCC	6	Gray (Red continuous)	A10	VCC
GND	5	Gray (Blue continuous)	B10	GND
NC	4		A11	NC
FG	1	Shield	B11	FG

I/O Flat Cable

Item **CB-DS-PIO** [] [] []

* [] [] [] indicates the cable length (L). A desired length up to 10 m can be specified. Example) 080 = 8 m

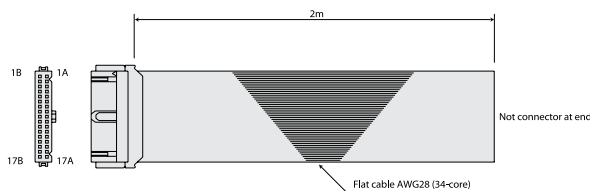

No.	Color	Wire	No.	Color	Wire
1A	Brown 1		9B	Gray 2	
1B	Red 1		10A	White 2	
2A	Orange 1		10B	Black 2	
2B	Yellow 1		11A	Brown-3	
3A	Green 1		11B	Red 3	
3B	Blue 1		12A	Orange 3	
4A	Purple 1		12B	Yellow 3	
4B	Gray 1		13A	Green 3	
5A	White 1		13B	Blue 3	
5B	Black 1	pressure-welded	14A	Purple 3	pressure-welded
6A	Brown-2		14B	Gray 3	
6B	Red 2		15A	White 3	
7A	Orange 2		15B	Black 3	
7B	Yellow 2		16A	Brown-4	
8A	Green 2		16B	Red 4	
8B	Blue 2		17A	Orange 4	
9A	Purple 2		17B	Yellow 4	

2-axis
Combinations
RCP2

2-axis
Combinations
RCS2

3-axis
Combinations
RCP2

3-axis
Combinations
RCS2

Controllers



RCS2-series
program controller

Model List/Pricing

A program controller capable of operating RCS2-series actuators. Various controls can be performed with a single unit.

Type	C	
Name	Program mode	Positioner mode
Exterior view		
Description	This controller can operate actuators and communicate with external devices without requiring any additional device. If two axes are operated, arc interpolation, path operation and synchronized operation can be performed.	Up to 20,000 positioning points are supported. Push-motion operation and teaching operation are also possible.
Number of positions	20,000	

Model

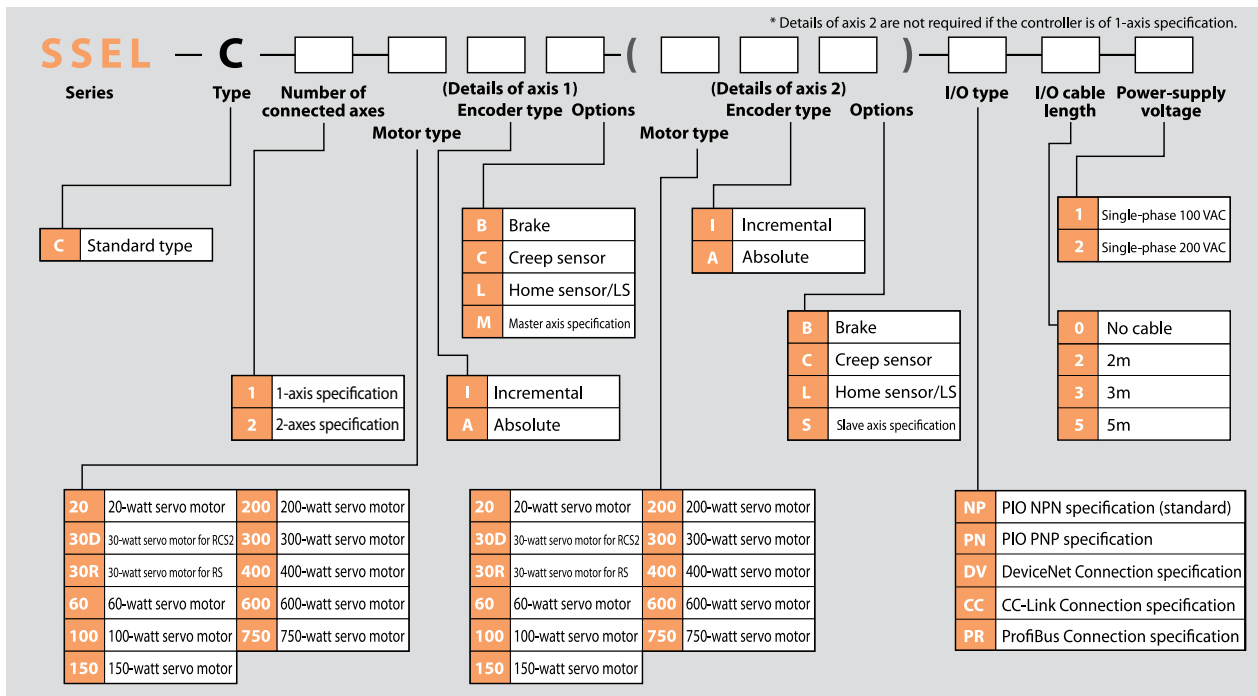

Model
List

PSEL

SSEL

ROBONET

XSEL

System Configuration

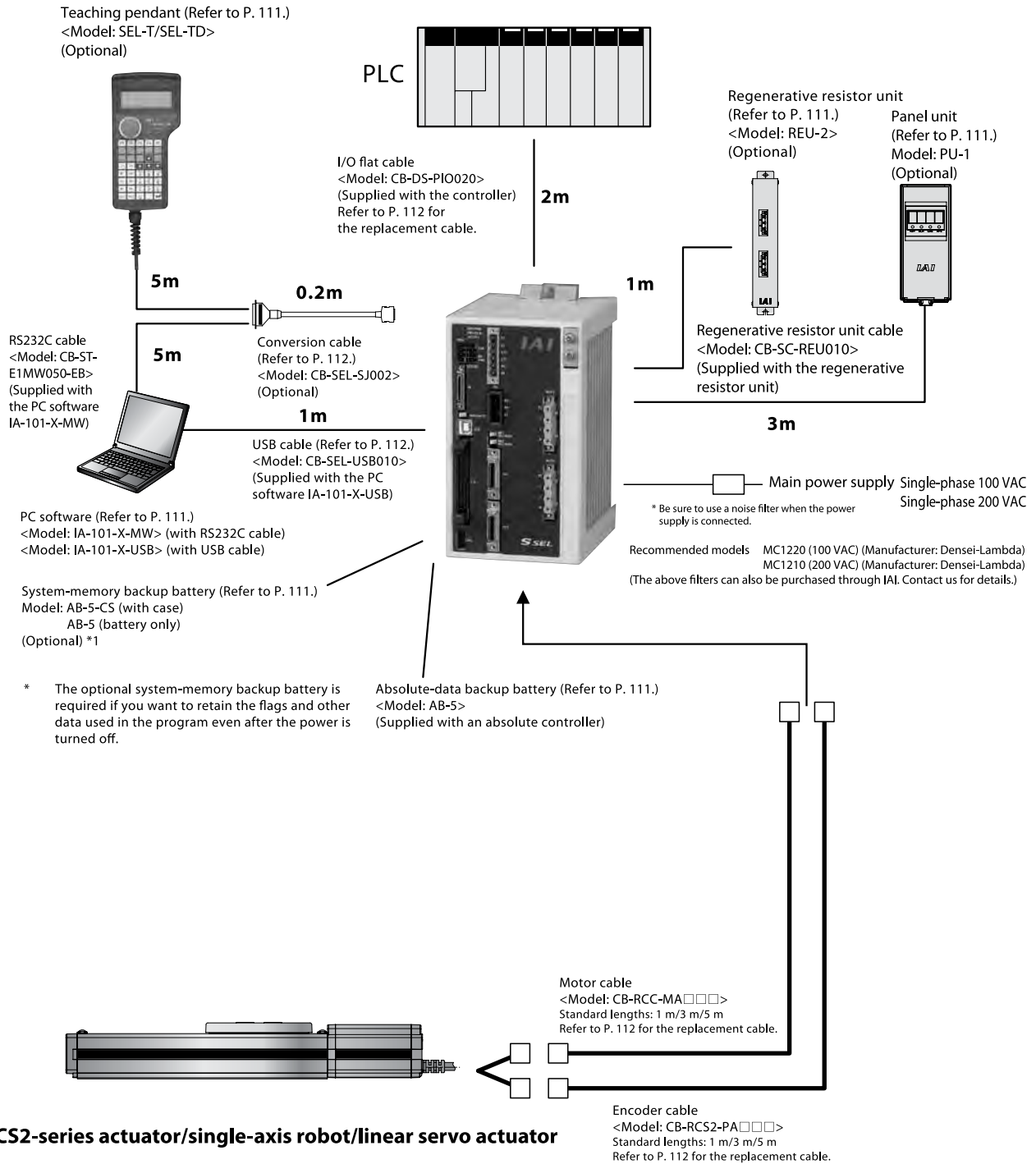

2-axis
Combinations
R C P 2

2-axis
Combinations
R C S 2

3-axis
Combinations
R C P 2

3-axis
Combinations
R C S 2

Controllers

Model
List

PSEL

SSEL

ROBONET

XSEL

I/O Specifications

Input External input specifications

Item	Specification
Input voltage	DC24V ±10%
Input current	7 mA per circuit
ON/OFF voltages	ON voltage (min.) NPN: DC16V/ PNP: DC8V OFF voltage (max.) NPN: DC5V/ PNP: DC19V
Insulation method	Photo-coupler

NPN specification

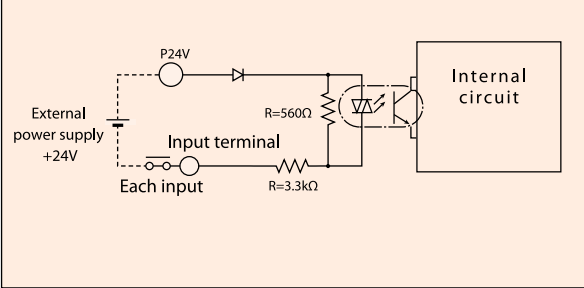

PNP specification

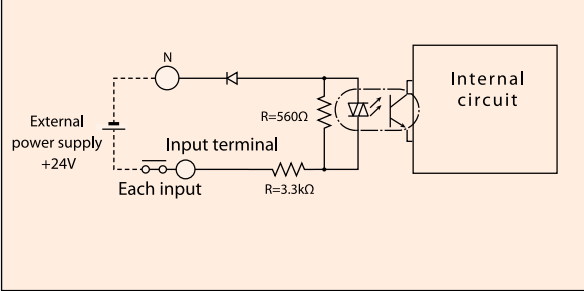

Output External output specifications

Item	Specification
Load voltage	DC24V
Maximum load current	100 mA per point, total 400 mA for 8 points
Leak current (max.)	Max. 0.1 mA per point
Insulation method	Photo-coupler

NPN specification

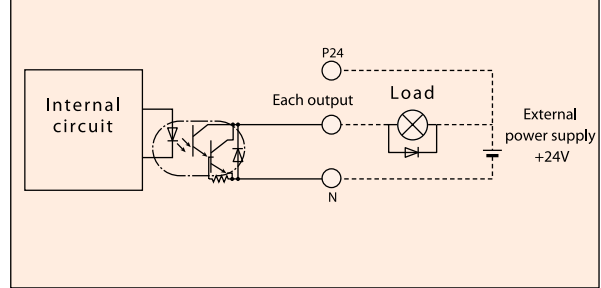

PNP specification

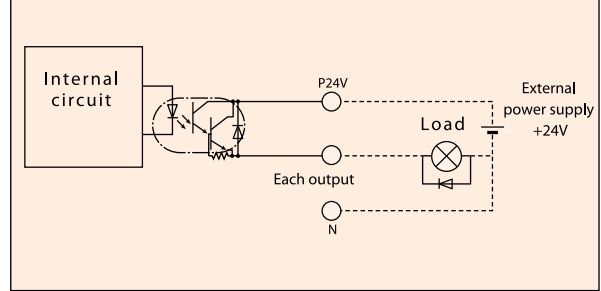

Explanation of I/O Functions

The SSEL controller can be operated in the “Program Mode” where a program is entered to operate the actuator or “Positioner Mode” where the actuator is moved to positions specified by signals received from a host PLC.

The positioner mode includes the following five input patterns to support various applications.

Functions by Controller Type

Operation mode	Features	
Program mode	You can use Super SEL, a language that allows for complex controls using simple commands, to perform linear and smooth interpolation operations, path operation ideal for coating and other applications, arch motion and palletizing operations, and more.	
Product-Type Switchover Mode	Standard mode	The basic operation mode where all you need is to specify a position number and enter a start signal. Push-motion operation, and linear interpolation operation of two axes, is also supported.
	Type switching mode	When the system handles multiple loads of the same shape but slightly different hole positions, you can issue movement commands to the same position number by changing the type number.
	2-axis independent mode	When a 2-axis controller is used, the two axes can be operated independently using separate commands.
	Teaching mode	The slider (rod) can be moved using an external signal to register the stopped position as position data.
	DS-S-C1 compatible mode	If you have been using a DS-S-C1 controller, you can swap it with a PSEL controller without having to change the host programs. * Compatibility with actuators is not assured.

Explanation of I/O Functions

Program Mode

Pin No.	Category	Port No.	Program Mode	Function	Wiring diagram	
1A	P24	016-023	24-V input	Connect 24 V.		
1B			Program No. 1 selection	Select the program number of the program you want to start. (Enter one of ports 016 to 022 by a BCD code.)		
2A			Program No. 2 selection			
2B			Program No. 4 selection			
3A			Program No. 8 selection			
3B			Program No. 10 selection			
4A			Program No. 20 selection			
4B			Program No. 40 selection			
5A			CPU reset			The system is reset and enters the same state achieved after the power has been reconnected.
5B			Start			The program selected by one of port Nos. 016 to 022 is started.
6A			General-purpose input			The system waits for an external input in response to a program command.
6B			General-purpose input			
7A			General-purpose input			
7B			General-purpose input			
8A			General-purpose input			
8B			General-purpose input			
9A			General-purpose input			
9B	General-purpose input					
10A	General-purpose input					
10B	General-purpose input					
11A	General-purpose input	These signals can be turned ON/OFF freely using program commands.				
11B	General-purpose input					
12A	General-purpose input					
12B	General-purpose input					
13A	General-purpose input					
13B	Alarm		This signal is output when an alarm has occurred. (Contact B)			
14A	Ready		This signal is output when the controller has started properly and become ready to operate.			
14B	General-purpose output					
15A	General-purpose output					
15B	General-purpose output					
16A	General-purpose output					
16B	General-purpose output					
17A	General-purpose output					
17B	N		OV input	Connect OV.		

Positioner, Standard Mode

Pin No.	Category	Port No.	Standard Positioner Mode	Function	Wiring diagram	
1A	P24	016-023	24-V input	Connect 24 V.		
1B			Position input 10	Use one of port Nos. 007 to 019 to specify the position number corresponding to the position to move the actuator to. The value can be specified by either a BCD or binary code.		
2A			Position input 11			
2B			Position input 12			
3A			Position input 13			
3B			Position input 14			
4A			Position input 15			
4B			Position input 16			
5A			Error reset			This signal resets minor errors. (The power must be reconnected to reset major errors.)
5B			Start			The actuator starts moving to the position corresponding to the selected position number.
6A			Home return			The actuator returns home.
6B			Servo ON	The servo is turned ON/OFF.		
7A			Push motion	The actuator performs push-motion operation.		
7B			Pause	The actuator pauses when this signal turns OFF, and resumes the remaining operation when the signal turns ON.		
8A			Cancel	The actuator stops when this signal turns OFF, and the remaining operation is cancelled.		
8B			Interpolation setting	In the case of a 2-axis specification, the actuators move via linear interpolation while this signal is ON.		
9A			Position input 1	Use one of port Nos. 007 to 019 to specify the position number corresponding to the position to move the actuator to. The value can be specified by either a BCD or binary code.		
9B	Position input 2					
10A	Position input 3					
10B	Position input 4					
11A	Position input 5					
11B	Position input 6					
12A	Position input 7					
12B	Position input 8					
13A	Position input 9					
13B	Alarm	This signal is output when an alarm has occurred. (Contact B)				
14A	Ready	This signal is output when the controller has started properly and become ready to operate.				
14B	Positioning complete	This signal is output when movement to the specified position has completed.				
15A	Home return complete	This signal is output when home return has completed.				
15B	Servo ON output	This signal is output while the servo is ON.				
16A	Push-motion complete	This signal is output when push-motion operation has completed.				
16B	System battery error	This signal is output when the system battery voltage has dropped (to the warning level).				
17A	Absolute battery error	This signal is output when the absolute battery voltage has dropped (to the warning level).				
17B	N		OV input	Connect OV.		

Explanation of I/O Functions

Positioner, Product-Type Switchover Mode

Pin No.	Category	Port No.	Type-switching Positioner Mode	Function	
1A	P24		24-V input	Connect 24 V.	
1B	Input	016	Position/type input 10	Use one of port Nos. 007 to 022 to specify the position number corresponding to the position to move the actuator to, and another to specify the type number. Assignment of position numbers and type numbers are set using parameters. The value can be specified by either a BCD or binary code.	
2A		017	Position/type input 11		
2B		018	Position/type input 12		
3A		019	Position/type input 13		
3B		020	Position/type input 14		
4A		021	Position/type input 15		
4B		022	Position/type input 16		
5A		023	Error reset		This signal resets minor errors. (The power must be reconnected to reset major errors.)
5B		000	Start		The actuator starts moving to the position corresponding to the selected position number.
6A	001	Home return	The actuator returns home.		
6B	002	Servo ON	The servo is turned ON/OFF.		
7A	Input	003	Push motion	The actuator performs push-motion operation.	
7B		004	Pause	The actuator pauses when this signal turns OFF, and resumes the remaining operation when the signal turns ON.	
8A		005	Cancel	The actuator stops when this signal turns OFF, and the remaining operation is cancelled.	
8B		006	Interpolation setting	In the case of a 2-axis specification, the actuators move via linear interpolation while this signal is ON.	
9A		007	Position/type input 1	Use one of port Nos. 007 to 022 to specify the position number corresponding to the position to move the actuator to, and another to specify the type number. Assignment of position numbers and type numbers are set using parameters. The value can be specified by either a BCD or binary code.	
9B		008	Position/type input 2		
10A		009	Position/type input 3		
10B		010	Position/type input 4		
11A		011	Position/type input 5		
11B	012	Position/type input 6			
12A	013	Position/type input 7			
12B	014	Position/type input 8			
13A	015	Position/type input 9			
13B	Output	300	Alarm	This signal is output when an alarm has occurred. (Contact B)	
14A		301	Ready	This signal is output when the controller has started properly and become ready to operate.	
14B		302	Positioning complete	This signal is output when movement to the specified position has completed.	
15A		303	Home return complete	This signal is output when home return has completed.	
15B		304	Servo ON output	This signal is output while the servo is ON.	
16A		305	Push-motion complete	This signal is output when push-motion operation has completed.	
16B		306	System battery error	This signal is output when the system battery voltage has dropped (to the warning level).	
17A		307	Absolute battery error	This signal is output when the absolute battery voltage has dropped (to the warning level).	
17B		N		OV input	Connect OV.

Wiring diagram

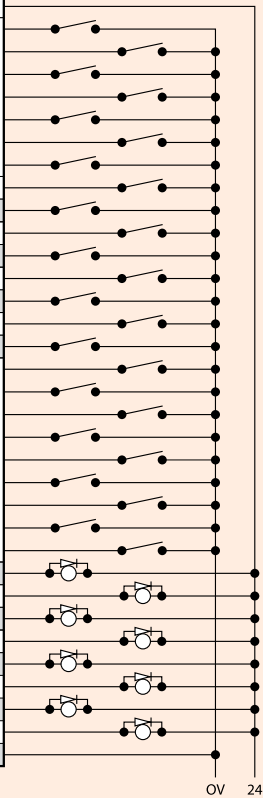

Positioner, 2-axes Independent Mode

Pin No.	Category	Port No.	Type-switching Positioner Mode	Function	
1A	P24		24-V input	Connect 24 V.	
1B	Input	016	Position input 7	Use any of port Nos. 010 to 022 to specify the position number corresponding to the position to move the actuator to. Assignment of position numbers for axes 1 and 2 are set using parameters. The value can be specified by either a BCD or binary code.	
2A		017	Position input 8		
2B		018	Position input 9		
3A		019	Position input 10		
3B		020	Position input 11		
4A		021	Position input 12		
4B		022	Position input 13		
5A		023	Error reset		This signal resets minor errors. (The power must be reconnected to reset major errors.)
5B		000	Start 1		Axis 1 starts moving to the selected position number.
6A	001	Home return 1	Axis 1 returns home.		
6B	002	Servo ON 1	The servo of axis 1 is turned ON/OFF.		
7A	Input	003	Pause 1	Axis 1 pauses when this signal turns OFF, and resumes the remaining operation when the signal turns ON.	
7B		004	Cancel 1	Movement of axis 1 is cancelled.	
8A		005	Start 2	Axis 2 starts moving to the selected position number.	
8B		006	Home return 2	Axis 2 returns home.	
9A		007	Servo ON 2	The servo of axis 2 is turned ON/OFF.	
9B		008	Pause 2	Axis 2 pauses when this signal turns OFF, and resumes the remaining operation when the signal turns ON.	
10A		009	Cancel 2	Movement of axis 2 is cancelled.	
10B		010	Position input 1	Use any of port Nos. 010 to 022 to specify the position number corresponding to the position to move the actuator to. Assignment of position numbers for axes 1 and 2 are set using parameters. The value can be specified by either a BCD or binary code.	
11A		011	Position input 2		
11B	012	Position input 3			
12A	013	Position input 4			
12B	014	Position input 5			
13A	015	Position input 6			
13B	Output	300	Alarm		This signal is output when an alarm has occurred. (Contact B)
14A		301	Ready		This signal is output when the controller has started properly and become ready to operate.
14B		302	Positioning complete 1		This signal is output when movement of axis 1 to the specified position has completed.
15A		303	Home return complete 1	This signal is output when home return of axis 1 has completed.	
15B		304	Servo ON output 1	This signal is output while the servo of axis 1 is ON.	
16A		305	Positioning complete 2	This signal is output when movement of axis 2 to the specified position has completed.	
16B		306	Home return complete 2	This signal is output when home return of axis 2 has completed.	
17A		307	Servo ON output 2	This signal is output while the servo of axis 2 is ON.	
17B		N		OV input	Connect OV.

Wiring diagram

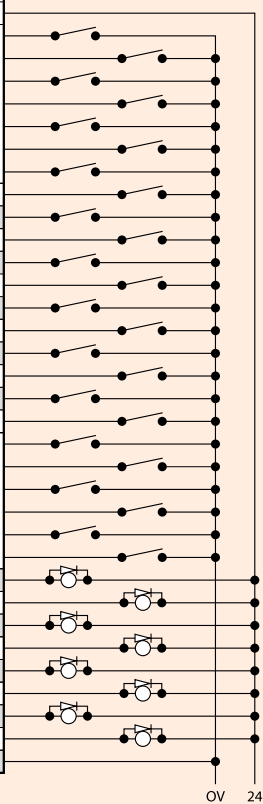

Explanation of I/O Functions

Positioner, Teaching Mode

Pin No.	Category	Port No.	Type-switching Positioner Mode	Function	Wiring diagram			
1A	P24	016	24-V input	Connect 24V.				
1B			Axis 1 JOG -	Axis 1 moves in the negative direction while this signal is input.				
2A			017	Axis 2 JOG +		Axis 2 moves in the positive direction while this signal is input.		
2B			018	Axis 2 JOG -		Axis 2 moves in the negative direction while this signal is input.		
3A			019	Inching specification (0.01 mm)		Specify the travel over which to move the actuator by inching. (The travel is the sum of values specified by port Nos. 019 to 022.)		
3B			020	Inching specification (0.1 mm)				
4A			021	Inching specification (0.5 mm)				
4B			022	Inching specification (1 mm)				
5A			023	Error reset			This signal resets minor errors. (The power must be reconnected to reset major errors.)	
5B			000	Start		The actuator starts moving to the position corresponding to the selected position number.		
6A			001	Servo ON		The servo is turned ON/OFF.		
6B			002	Pause		The actuator pauses when this signal turns OFF, and resumes the remaining operation when the signal turns ON.		
7A			Input	003		Position input 1	Use one of port Nos. 003 to 013 to specify the position number corresponding to the position to move the actuator to, and another to specify the position number under which to input the current position. If port No. 14 for teaching mode specification is ON, the current value is written to the specified position number when port No. 000 for start signal turns ON.	
7B						004		Position input 2
8A						005		Position input 3
8B						006		Position input 4
9A						007		Position input 5
9B	008	Position input 6						
10A	009	Position input 7						
10B	010	Position input 8						
11A	011	Position input 9						
11B	012	Position input 10						
12A	013	Position input 11						
12B	014	Teaching mode specification						
13A	Output	300	Axis 1 JOG +	Axis 1 moves in the positive direction while this signal is input.				
13B			Alarm	This signal is output when an alarm has occurred. (Contact B)				
14A			301	Ready	This signal is output when the controller has started properly and become ready to operate.			
14B			302	Positioning complete	This signal is output when movement to the specified position has completed.			
15A			303	Home return complete	This signal is output when home return has completed.			
15B			304	Servo ON output	This signal is output while the servo is ON.			
16A			305	-	-			
16B	306	System battery error	This signal is output when the system battery voltage has dropped (to the warning level).					
17A	N	307	Absolute battery error	This signal is output when the absolute battery voltage has dropped (to the warning level).				
17B			OV input	Connect OV.				

Positioner, DS-S-C1 Compatible Mode

Pin No.	Category	Port No.	Standard Positioner Mode	Function	Wiring diagram			
1A	P24	016	24-V input	Connect 24V.				
1B			Position No. 1000	(Same with port Nos. 004 to 015.)				
2A			017	Position No. 2000		-		
2B			018	Position No. 4000		-		
3A			019	Position No. 8000		-		
3B			020	Position No. 10000		-		
4A			021	Position No. 20000		-		
4B			022	NC (*1)		-		
5A			023	CPU reset		The system is reset and enters the same state achieved after the power has been reconnected.		
5B			000	Start		The actuator starts moving to the position corresponding to the selected position number.		
6A			001	Hold (pause)		The actuator pauses when this signal turns ON, and resumes the remaining operation when the signal turns OFF.		
6B			002	Cancel		The actuator stops when this signal turns ON, and the remaining operation is cancelled.		
7A			Input	003		Interpolation setting	In the case of a 2-axis specification, the actuators move via linear interpolation while this signal is ON. Use one of port Nos. 004 to 016 to specify the position number corresponding to the position to move the actuator to. The value is specified by a BCD code.	
7B						004		Position No. 1
8A						005		Position No. 2
8B						006		Position No. 4
9A						007		Position No. 8
9B	008	Position No. 10						
10A	009	Position No. 20						
10B	010	Position No. 40						
11A	011	Position No. 80						
11B	012	Position No. 100						
12A	013	Position No. 200						
12B	014	Position No. 400						
13A	Output	300	Alarm	This signal is output when an alarm has occurred. (Contact A)				
14A			301	Ready	This signal is output when the controller has started properly and become ready to operate.			
14B			302	Positioning complete	This signal is output when movement to the specified position has completed.			
15A			303	-	-			
15B			304	-	-			
16A			305	-	-			
16B			306	System battery error	This signal is output when the system battery voltage has dropped (to the warning level).			
17A	N	307	Absolute battery error	This signal is output when the absolute battery voltage has dropped (to the warning level).				
17B			OV input	Connect OV.				

(*1) This input must be turned OFF. Make sure the signal is not connected.

2-axis Combinations R C P 2

2-axis Combinations R C S 2

3-axis Combinations R C P 2

3-axis Combinations R C S 2

Controllers

Model List

PSEL

SSEL

ROBONET

XSEL

Specification Table

	Item	Specification
Base specifications	Connected actuator	RCS2-series actuator/single-axis robot/linear servo actuator
	Input power supply	Single-phase 100 VAC ±10%
	Power-supply capacity	Max. 1660 VA (400 W, 2-axis operation)
	Dielectric strength	500 VDC, 10 MΩ or more
	Withstand voltage	500 VAC, 1 minute
	Rush current	Max. 30 A
Control specifications	Vibration resistance	XYZ directions: 10 to 57 Hz: (Single amplitude) 0.035 mm (continuous), 0.0 75 mm (intermittent) 58 to 150 Hz: 4.9 m/sec2 (continuous), 9.8 m/sec2 (intermittent)
	Number of controlled axes	1/2
	Maximum total output of connected axes	400 W 800 W
	Position detection method	Incremental encoder/Absolute encoder
Program	Speed setting	1 mm/sec ~ (The maximum limit varies depending on the actuator.)
	Acceleration setting	0.01 G ~ (The maximum limit varies depending on the actuator.)
Communication related	Operation method	Program operation/positioner operation (switchable)
	Program language	Super SEL
	Number of programs	128 (*1)
	Number of program steps	9999 (*1)
	Number of multi-tasking programs	8
	Number of positioning points	20000 (*1)
General specifications	Data storage device	Flash ROM (An optional system-memory backup battery can be added.)
	Data input method	Teaching pendant or PC software
	Number of I/O points	24 input points/8 output points (NPN/PNP selectable)
	I/O power supply	24 VDC ±10%, externally supplied
	PIO cable	CB-DS-PIO□□□ (supplied with the controller)
	Serial communication function	RS232C (half-pitch connector)/USB connector
	Field network cable	(To be supported in the future)
	Motor cable	CB-RCC2-MA□□□ (max. 20 m)
	Encoder cable	CB-RCS2-PA□□□ (max. 20 m)
	Protective functions	Motor overcurrent, motor/driver temperature check, overload check, encoder open check, soft limit overtravel, system battery error, etc.
	Surrounding air temperature/humidity	0 to 40°C, 10 to 95% (non-condensing)
	Surrounding ambience	Free from corrosive gases or significant dust.
	Protection degree	IP20
	Weight	1.4 kg
	External dimensions	100 mm (W) x 202.6 mm (H) x 126 mm (D)

(*1) These specifications are different for PNP controllers. Contact IAI for details.

External Dimensions

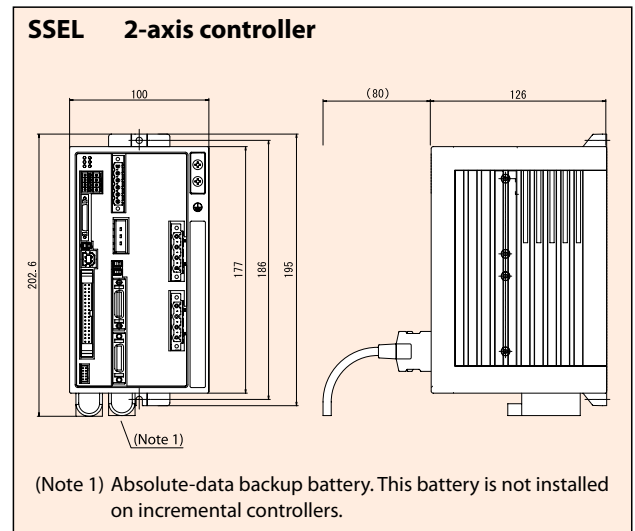
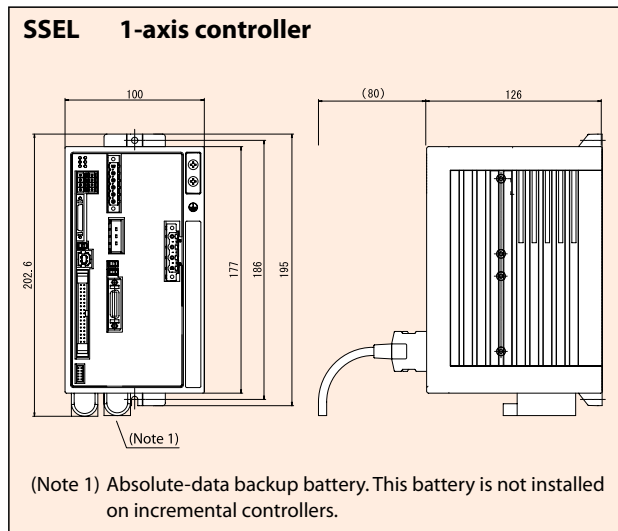

Name of Each Part

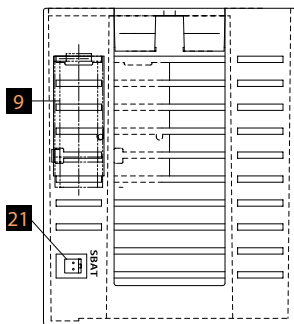
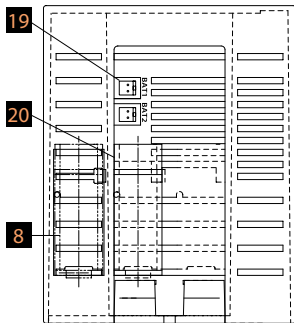
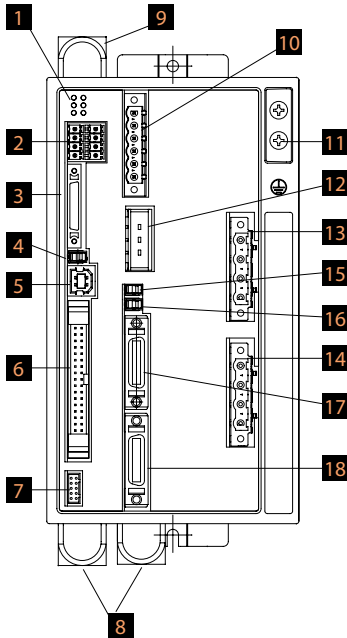

1 Status indicator LEDs

These LEDs indicate the operating status of the controller. What is indicated by each LED is explained below:

PWR: The power is currently input to the controller.

RDY: The controller is ready to perform program operation.

ALM: The controller is abnormal.

EMG: An emergency stop has been actuated and the drive source is being cut off.

SV1: The servo of actuator axis 1 is turned ON.

SV2: The servo of actuator axis 2 is turned ON.

2 System I/O connector

This connector connects the emergency stop input, enable input, brake power input, etc.

3 Teaching pendant connector

This half-pitch, 1026-pin connector is used to connect a teaching pendant when the operation mode is MANU. You need a dedicated conversion cable to connect to a conventional D-sub, 25-pin connector.

4 Mode switch

This switch is used to indicate the operation mode of the controller. The left position indicates the MANU (manual operation) mode, while the right position indicates the AUTO (auto operation) mode. Teaching operation can only be performed in the MANU mode, and auto operation using external I/Os cannot be performed in the MANU mode.

5 USB connector

This connector is used to make USB connection with a PC. When the USB connector is in use, the TP connector cannot be used because communication through the TP connector is cut off.

6 IO connector

A connector for interface I/Os. If a DIO (24IN/8OUT) interface is used, this connector accepts a 34-pin flat cable connector. The I/O power is also supplied to the controller through this connector (pins 1 and 34).

7 Panel unit connector

This connector is used to connect the panel unit (optional) for displaying the controller status and error numbers.

8 Absolute-data backup battery

This battery is used to retain position data even after the power is cut off when an absolute axis is operated.

9 System-memory backup battery (optional)

This connector is used to connect the battery needed to retain the various data stored in the built-in SRAM of the controller even after the power is cut off. The system-memory backup battery is an optional. Specify the battery only if necessary.

10 Power-supply connector

A connector for AC power supply. The control power and motor power are input separately.

11 Grounding screw

A screw for protective grounding. Be sure to connect this screw to ground.

12 External regenerative resistor connector

This connector is used to connect an additional regenerative resistor when the built-in regenerative resistor is not enough due to high acceleration, high load, etc.

Whether or not an external regenerative resistor is needed depends on the specifics of the application, such as the axis configuration.

13 Axis 1 motor connector

Connect the motor cable for actuator axis 1 here.

14 Axis 2 motor connector

Connect the motor cable for actuator axis 2 here.

15 Axis 1 brake switch

This switch is used to release the axis brake. When the switch is set to the left (RLS) position, the brake is forcibly released. When the switch is set to the right (NOM) position, the brake is controlled automatically by the controller.

16 Axis 2 brake switch

This switch is used to release the axis brake. When the switch is set to the left (RLS) position, the brake is forcibly released. When the switch is set to the right (NOM) position, the brake is controlled automatically by the controller.

17 Axis 1 encoder connector

Connect the encoder cable for actuator axis 1 here.

18 Axis 2 encoder connector

Connect the encoder cable for actuator axis 2 here.

19 Axis 1 absolute battery connector

This connector is used to connect the absolute-data backup battery for axis 1 when the actuator is equipped with an absolute encoder.

20 Axis 2 absolute battery connector

This connector is used to connect the absolute-data backup battery for axis 2 when the actuator is equipped with an absolute encoder.

21 System-memory backup battery connector

This connector is used to connect the system-memory backup battery.

Options

Teaching Pendant

Features A teaching device offering functions for program/position input, test operation, monitoring, and more.

Model/Price

Model	Description
SEL-T-J	Standard type with connector conversion cable
SEL-TD-J	Deadman switch type with connector conversion cable

Configuration

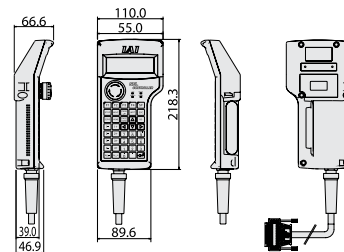
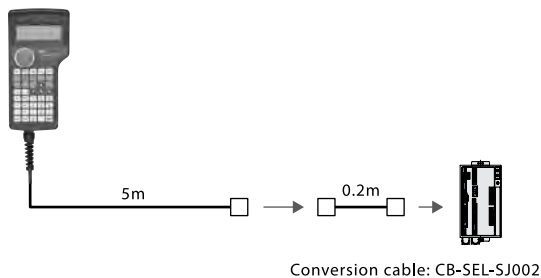

Specification

Item	SEL-T-J	SEL-TD-J
3-position enable switch	Not equipped	Equipped
ANSI/UL standard	Not compliant	Compliant
CE mark	Compliant	
Display	20 characters x 4 lines	
Surrounding air temperature/humidity	0-40°C 10-90%RH (non-condensing)	
Protection structure	IP54	
Weight	Approx. 0.4 kg (excluding cables)	

PC Software (Windows only)

Features A software program that assists the initial startup of your system, offering functions for program/position input, test operation, monitoring, and more. The enhanced debugging functions help reduce the startup time.

Model **IA-101-X-MW-J** (with RS232C cable + connector conversion cable)
IA-101-X-MW (with RS232C cable)

Configuration

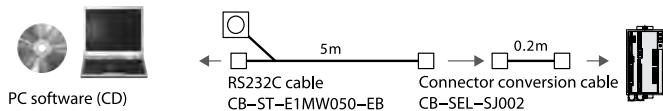

Model **IA-101-X-USB** (with USB cable)

Configuration

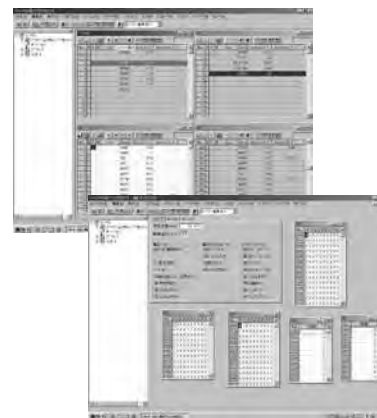
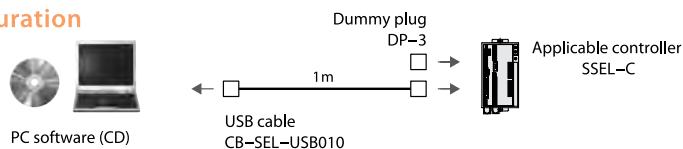

Note
The SSEL controller only supports version 6.0.0.0 or later.

Regenerative Resistor Unit

Features This unit converts to heat the regenerative current produced when the motor decelerates. Use the table on the right to check the total wattage of the actuators to be operated, and provide a regenerative resistor or resistors if necessary.

Item **REU-2** (for SCON/SSEL)

Specification

Weight	0.9kg
Built-in regenerative resistor	220Ω 80W
Unit-controller connection cable (supplied)	CB-SC-REU010 (for SSEL)

Guide for Determining Necessary Number of Regenerative Resistor Units

	Horizontal	Vertical
0 unit	~800W	~200W
1 unit		~600W
2 unit		~800W

* Depending on the operating conditions, the required number of regenerative resistor unit(s) may be more than what is specified above.

* If two regeneration units are required, order one REU-2 and one REU-1 (refer to P. 132).

External Dimensions

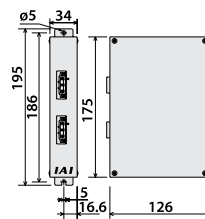

Panel Unit

Features A display for checking controller error codes and the program number of the current program.

Model **PU-1** (cable length: 3 m)

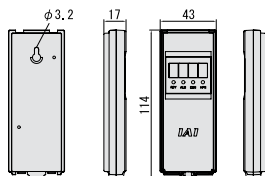

Absolute-data Backup Battery

Features An absolute-data backup battery used when an absolute actuator is operated. The battery is the same as the system-memory backup battery.

Model **AB-5**



System memory backup battery

Features This battery is needed when global flags, etc., are used in the program and you want the data to be retained even after the power is turned off.

Model **AB-5-CS** (with case)
AB-5 (battery)



Options

Dummy plug

Features This plug is connected to the teaching pendant to cut off the enable circuit when connecting the SSEL controller to a PC via a USB cable. (This plug is supplied with the PC software IA-101-X-USB.)

Model DP-3



USB cable

Features This cable is used to connect a controller with USB port to a PC. To connect a controller without USB port (XSEL) to a PC, connect the controller's RS232C cable to a USB cable via a USB conversion adapter and connect the USB cable to the USB port on the PC. (Refer to the PC software IA-101-X-USBMW.)

Model CB-SEL-USB010 (cable length: 1 m)



Connector conversion cable

Features This conversion cable is used to connect the D-sub, 25-pin connector for teaching pendant or PC to the teaching connector (half-pitch) on the SSEL controller.

Model CB-SEL-SJ002 (cable length: 0.2 m)



Replacement Parts

If you must order a replacement cable, etc., after the initial purchase of your product, specify the correct model by referring to the information below.

Motor Cable/Robot Motor Cable

Item **CB-RCC-MA**□□□□ / **CB-RCC-MA**□□□□-RB

* □□□□ indicates the cable length (L). A desired length up to 30 m can be specified. Example) 080 = 8 m

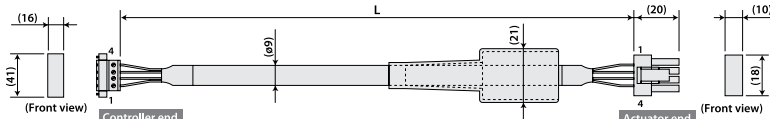

Wire	Color	Signal	No.	Signal	Color	Wire
0.75sq	Green	PE	1	1	U	Red
	Red	U	2	2	V	White
	White	V	3	3	W	Black
	Black	W	4	4	PE	Green

Encoder Cable/Robot Encoder Cable

Item **CB-RCS2-PA**□□□□ / **CB-X3-PA**□□□□

* □□□□ indicates the cable length (L). A desired length up to 30 m can be specified. Example) 080 = 8 m

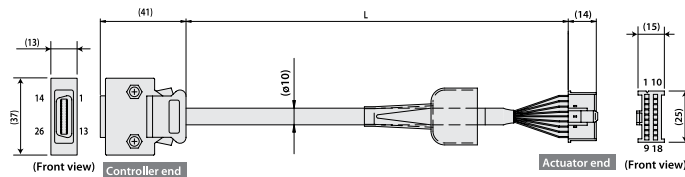

Wire	Color	Signal	No.	No.	Signal	Color	Wire
AWG26 (Soldered)	White	A+	1	1	A	White/Blue	AWG26 (Crimped)
	White	A-	2	2	B	White/Orange	
	White	B+	3	3	B	White/Blue	
	White	B-	4	4	CRSP	Brown/Yellow	
	Green	VCC	16	5	OT	Brown/Red	
	Green	VCC	16	6	RSV	Brown/Black	
	Brown	GND	17	7	LS	Orange/White	
	Gray	SRD+	20	8	LS+	Green/White	
	Red	SRD-	21	9	LS-	Brown/White	
	Black	BAT+	14	10	FG	Ground	
	Yellow	BAT-	15	10	SD	Blue	
	Green	VCC	16	11	SP	Orange	
	Blue	GND	17	12	BAT+	Black	
	Gray	SRD+	20	13	BAT-	Yellow	
	Red	SRD-	21	14	VCC	Green	
	Black	SRD-	22	15	GND	Brown	
				16	LS	Gray/White	
				17	BK-	Gray	
				18	BK+	Red	

Encoder Cable/Robot Encoder Cable for RCS2-RT6/RT6R/RT7R

Item **CB-RCS2-PLA**□□□□ / **CB-X2-PLA**□□□□

* □□□□ indicates the cable length (L). A desired length up to 30 m can be specified. Example) 080 = 8 m

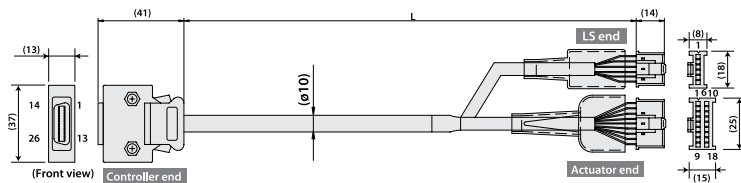

Wire	Color	Signal	No.	No.	Signal	Color	Wire
AWG26 (Soldered)	White/Orange	E4W	11	1	A	White/Blue	AWG26 (Crimped)
	White/Green	dv	13	2	dy	White/Green	
	Brown/Blue	LS	26	3	LS	Brown/Blue	
	Brown/Red	CRSP	25	4	CRSP	Brown/Yellow	
	Brown/Black	OT	24	5	OT	Brown/Red	
	Green/Black	RSV	23	6	RSV	Brown/Black	
				7	LS	Orange/White	
				8	LS+	Green/White	
				9	LS-	Brown/White	
				10	SD	Blue	
				11	SP	Orange	
				12	BAT+	Black	
				13	BAT-	Yellow	
				14	VCC	Green	
				15	GND	Brown	
				16	LS	Gray/White	
				17	BK-	Gray	
				18	BK+	Red	

I/O Flat Cable

Item **CB-DS-PIO**□□□□

* □□□□ indicates the cable length (L). A desired length up to 10 m can be specified. Example) 080 = 8 m

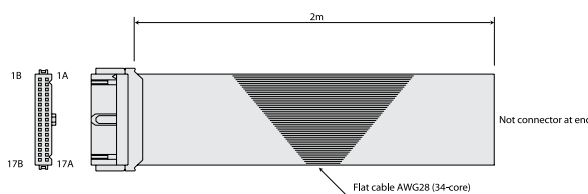

No.	Color	Wire	No.	Color	Wire
1A	Brown 1		9B	Gray 2	
1B	Red 1		10A	White 2	
2A	Orange 1		10B	Black 2	
2B	Yellow 1		11A	Brown-3	
3A	Green 1		11B	Red 3	
3B	Blue 1		12A	Orange 3	
4A	Purple 1		12B	Yellow 3	
4B	Gray 1		13A	Green 3	
5A	White 1		13B	Blue 3	
5B	Black 1		14A	Purple 3	
6A	Brown-2		14B	Gray 3	
6B	Red 2		15A	White 3	
7A	Orange 2		15B	Black 3	
7B	Yellow 2		16A	Brown-4	
8A	Green 2		16B	Red 4	
8B	Blue 2		17A	Orange 4	
9A	Purple 2		17B	Yellow 4	

2-axis Combinations RCP2
 2-axis Combinations RCS2
 3-axis Combinations RCP2
 3-axis Combinations RCS2
 Controllers
 Model List
 PSEL
 SSEL
 ROBOTNET
 XSEL

ROBONET



Dedicated field network controller

The ROBONET is a new type of controller unit capable of operating ROBO Cylinders at will via a field network. Adopting the wire-saving design, compact size and DIN-rail installation feature, the ROBONET lets you save the hassle of wiring and installation considerably compared to existing controllers.

Standard type

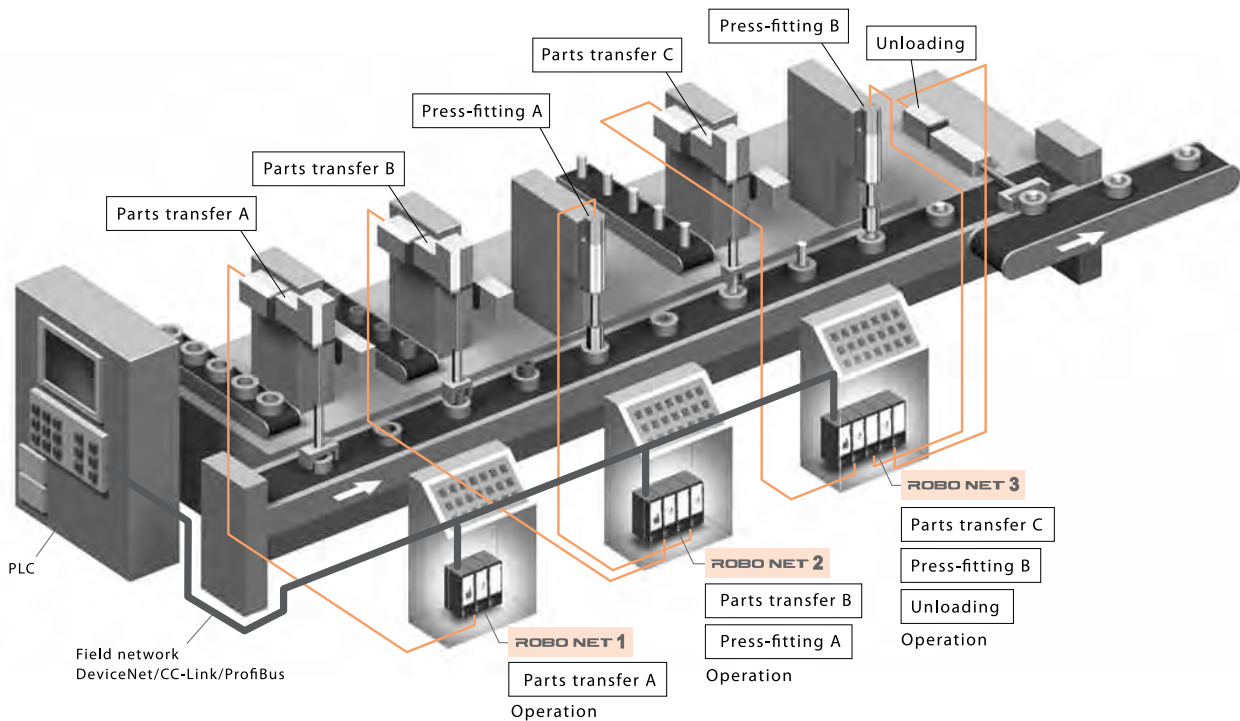

1 Wire-saving

Instead of connecting the I/O cables one by one to the PLC terminal, all I/Os can be connected via a field network. This means all you need to complete the wiring is to connect one dedicated cable. Also, units can be linked simply by interconnecting the unit connection boards, which significantly reduces the hassle of controller wiring.

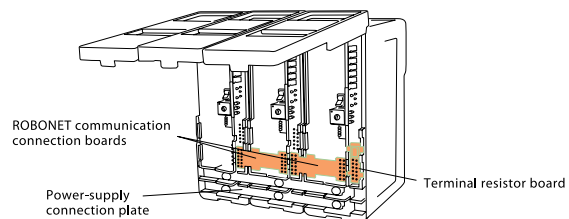
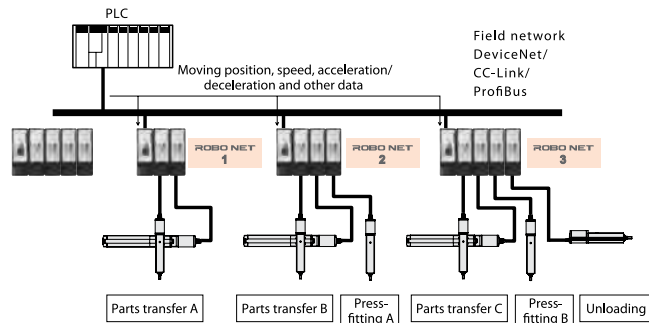

2 Operation by Direct Numerical Specification of Moving Position, Speed, Acceleration/Deceleration, Etc.

In addition to using the traditional method of entering moving positions and speeds under position numbers and then specifying desired position numbers eternally, you can also send moving positions (coordinates), speeds, accelerations/decelerations, etc., as numeric data to operate the actuator. This method is effective in situations where the moving position changes for each load or you want to move the load to a desired position.

	ROBONET controller	Standard controller (ACON/PCON)
Movement by position specification	○	○
Movement by direct numerical specification	○	△
Speed/acceleration specification	○	(Not supported in the PIO mode) (Supported in the serial communication mode.)
Current value output	○	

* The ROBONET operates via a field network, while the standard controller operates using PIOs.

3 Ultra-compact

Each unit adopts an ultra-compact size of just 34 mm (w) x 100 mm (h) x 73 mm (d). Since there is no base unit and the controllers are linked using connectors, the installation space is minimized even when many units must be connected.

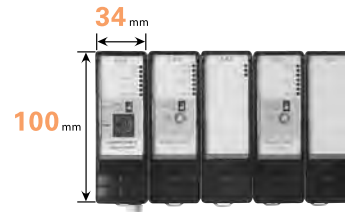

4 Up to 16 Controllers Can Be Operated

Up to 16 controller units can be connected to one communication unit (Gateway R unit). You can connect a desired combination of RACON units (RCA controllers) and RPCON units (RCP2 controllers).

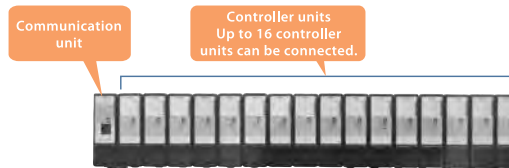

5 Simple Absolute Specification Not Requiring Home Return

The simple absolute R unit lets you operate incremental axes without returning the axes to their home first. If a simple absolute R unit is installed on an RACON unit (RCA controller) or RPCON unit (RCP2 controller), the actuator's encoder data will be backed up even after the power is cut off.



6 Installation to DIN Rail

Since the ROBONET adopts a DIN-rail installation feature, each controller can be affixed or removed with a single touch.

2-axis
Combinations
RCP2

2-axis
Combinations
RCS2

3-axis
Combinations
RCP2

3-axis
Combinations
RCS2

Controllers

Model
List

PSEL

SSEL

ROBONET

XSEL

System Configuration

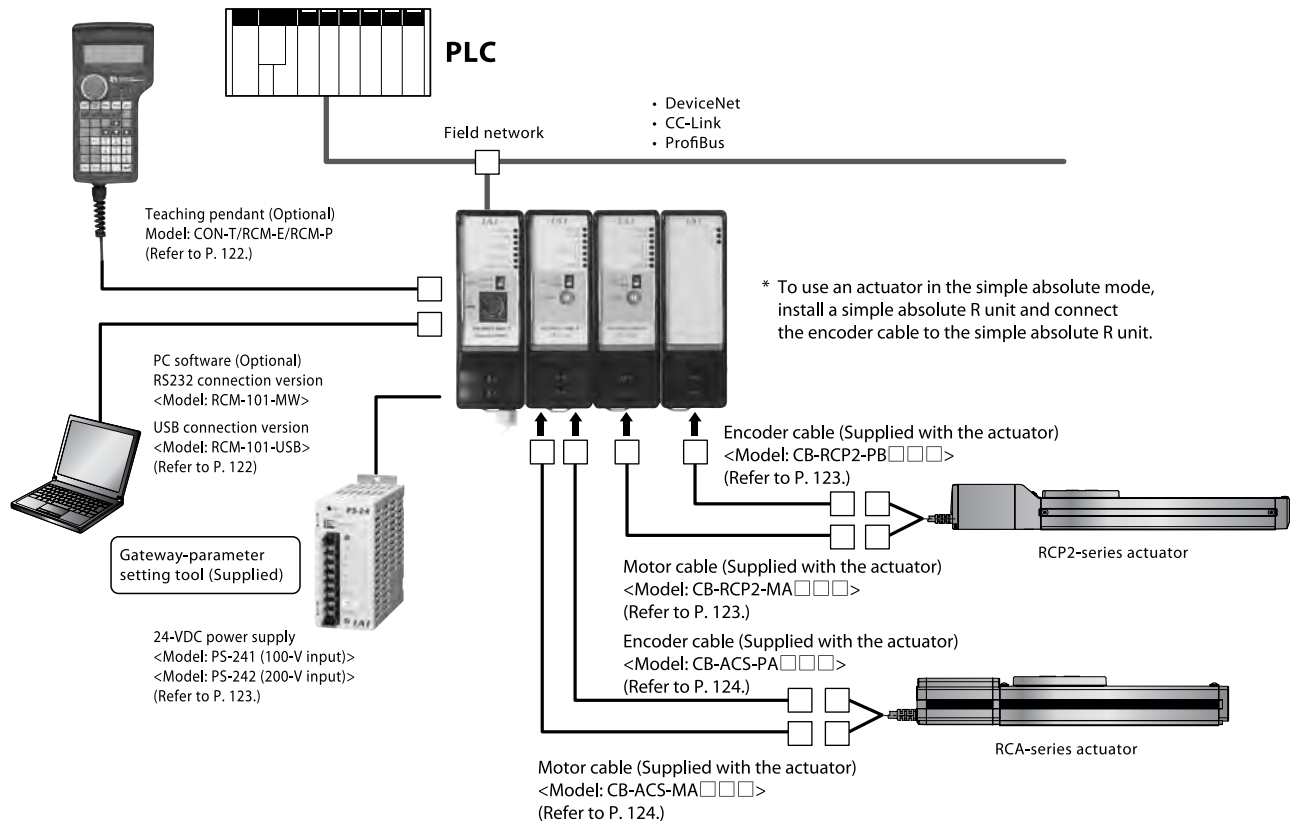

ROBONET Expansion unit

The ROBONET expansion unit (optional) lets you fold the unit link using a cable when many ROBONET units have been connected and the system has become too wide. You can also connect an SCON or other standalone controller to the network via the ROBONET.

[ROBONET expansion set A]

(Unit-folding set)

Model: REXT-SIO

(Items included in the set)

ROBONET expansion unit (model: REXT)	x 2
Unit link cable	x 1
Model: CB-REXT-SIO010	

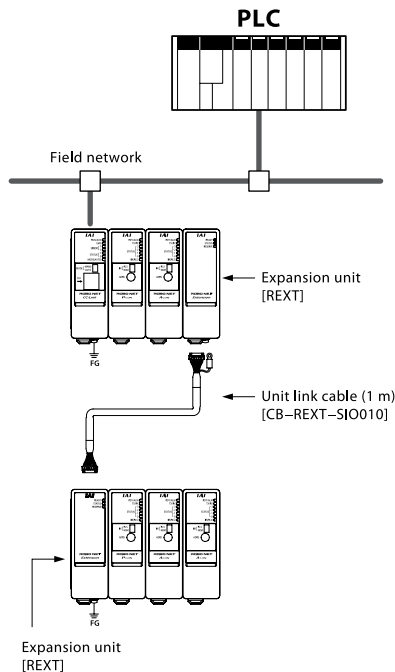

[ROBONET expansion set B]

(Controller connection set)

Model: REXT-CTL

(Items included in the set)

ROBONET expansion unit (model: REXT)	x 1
Controller connection cable	x 1
Model: CB-REXT-CTL010	

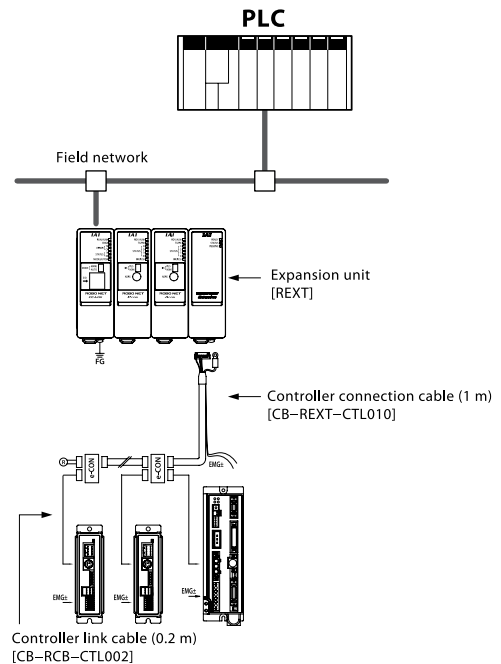

Component Units

You can order the necessary ROBONET components individually and combine them at your will.

If a need arises to add an actuator later, you can extend the system simply by adding an RACON/RPCON unit.



Gateway unit RACON unit RPCON unit Simple absolute R unit Expansion unit

Unit name	Description	Reference page
Gateway unit	A unit for making connection to a field network. One of four types (DeviceNet, CC-Link, Profibus and SIO) can be selected. * This unit is required in every ROBONET configuration.	P118 P119
RACON unit	A controller unit for operating an RCA actuator. (One RACON is required for one actuator axis.) Although the standard specification is incremental, you can also combine a simple absolute R unit to use the RACON unit as a simple absolute controller.	P120
RPCON unit	A controller unit for operating an RCP2 actuator. (One RPCON is required for one actuator axis.) Although the standard specification is incremental, you can also combine a simple absolute R unit to use the RPCON unit as a simple absolute controller.	P120
Simple absolute R unit	A backup battery unit for retaining the encoder data of the actuator after the power is cut off.	P121
Expansion unit	A unit for enabling operation via a network by folding the ROBONET link or connecting a standalone controller (SCON/PCON-CF) to the ROBONET.	P121

How to Order/Notes

You can individually order the necessary units comprising your ROBONET system. The delivered units are assembled by the customer. This feature lets you add units to the system or change existing units at will.

<Example of order> The following two axes are operated via CC-Link. The models specified below assume that the system is intended as an absolute system.

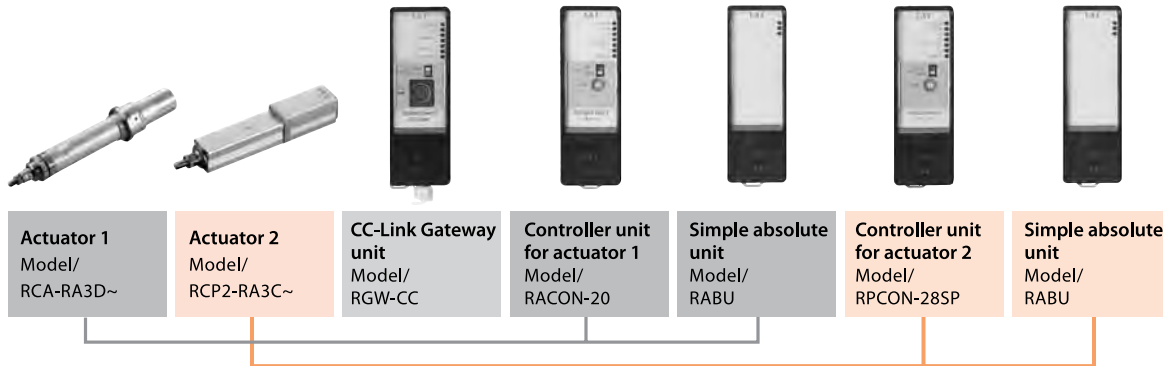

- **Operation Manual** The operation manual that comes with each ROBONET product is provided in a CD-ROM, not on paper (as a paper manual). If you wish to have a paper operation manual, please specify so in your order. (Both the CD-ROM and paper manuals are free.)
You can also download the operation manual from our website.
- **Gateway-parameter Setting Tool** To connect the ROBONET to a field network, you need the gateway-parameter setting tool to set up the network. This tool can be obtained free of charge through the following methods:
(1) Download the tool from IAI's website.
(2) Purchase each PC software, and the tool will come with the PC software (included in the CD).
To use the gateway-parameter setting tool, you need a cable to connect the PC and controller (PC software cable (model: CB-RCA-SIO050+RCB-CV-MW)). If you don't have any PC software, purchase this cable separately.
- **PC Software, Teaching Pendant** To input position data, etc., to a ROBONET controller unit (RACON/RPCON), you need the PC software or teaching pendant.
The ROBONET supports the PC software (model: RCM-101-MW/USB) of Version 6.04 or later. As for teaching pendants, the ROBONET supports the RCM-T of Version 2.06 or later and RCM-E/RCM-P of Version 2.08 or later.
The ROBONET can be used with any version of the CON-T.
If the version of your current PC software or teaching pendant is old, contact your IAI representative.

Explanation of Operation Modes

The ROBONET operates by receiving instructions from a PLC via a field network.

The ROBONET can be operated in any of the three modes specified below. Use a desired mode according to how your system should be operated and controlled.

	Name	Description
1	Positioner mode	In this mode, the actuator is operated by specifying position numbers. The position data, speed, acceleration/ deceleration, etc., are input to the position table beforehand. Up to 768 positions can be registered.
2	Simple direct mode	In this mode, only the position data is specified directly by a value, and the remaining items such as speed, acceleration/deceleration, positioning band and current-limiting value during push-motion operation are specified by a position number. Up to 768 positions can be registered.
3	Direct numerical specification mode	In this mode, the actuator is operated by specifying the position data, speed, acceleration/deceleration, positioning band and current-limiting value during push-motion operation directly by values. Since positions are specified numerically, there is no limit to the number of positioning points that can be registered.

List of Functions by Operation Mode

	Positioner mode	Simple direct mode	Direct numerical specification mode
Number of registerable positions	768	768	—
Movement by position number specification	○	×	×
Direct specification of position data	×	○	○
Direct specification of speed and acceleration/deceleration	×	×	○
Direct specification of positioning band	×	×	○
Push-motion operation	○	○	○
Monitoring of completed position number	○	○	×
Monitoring of zone output	○	○	○
Monitoring of position zone output	○	○	×
Teaching function	○	×	×
Jogging operation	○	○	○
Inching operation	○	○	○
Monitoring of various status signals (*)	○	○	○
Monitoring of current position (*)	○	○	○
Monitoring of alarm codes (*)	○	○	○
Monitoring of speed/current (*)	×	×	○
Maximum specifiable value of position data	9999.99mm	9999.99mm	9999.99mm
Number of connectable axes	16	16	8

* The various status signals, current position, alarm codes and speed/current can be monitored by accessing each address of the Gateway R unit from the PLC.

Explanation of Component Units (Gateway R Unit)

Gateway R Unit of DeviceNet Specification



This communication unit is used to operate the ROBONET via DeviceNet.

Model **RGW-DV**

Specification

Item	Specification	Item	Specification		
Power supply	DC24V ±10%	DeviceNet specifications	Communication cable length (*)		
Current consumption	Max. 600 mA			Baud rate	Maximum network length
DeviceNet specifications	Communication protocol			Maximum branch length	Total branch length
				250kbps	250m
		125kbps	500m	78m	
	Certified DeviceNet 2.0 interface module		156m		
	Group 2 only server		Note) When a thick DeviceNet cable is used.		
	Insulation node of network-power operation type	Number of occupied nodes	1 node		
	Bit strobe	Surrounding air temperature	0~40°C		
	Master-slave connection	Surrounding humidity	95% RH or below (non-condensing)		
	Polling	Operating ambience	Free from corrosive gases, flammable gas, oil mist or powder dust.		
	Cyclic	Environment conditions			
Baud rate	500k/250k/125kbps (switchable using dedicated software)	Protection degree	IP20		
		Weight	140g		
		Accessories	Terminal resistor board (model:TN-1) Network connector/emergency stop connector		

*1 If T-branching communication is to be used, refer to the operation manuals of the master unit and PLC installed in the master unit.

Network Connector

Gateway connector:
MSTBA2.5/5-G-5.08 ABGY AU
(by Phoenix Contact)

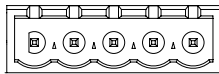

Cable-end connector
MSTB2.5/5-ST-5.08 ABGY AU
(by Phoenix Contact)
= Standard accessory

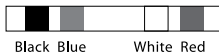

Pin color	Explanation
Black	Power-supply cable -
Blue	Communication data low
-	Shield
White	Communication data high
Red	Power-supply cable +

Applicable Wire for Cable-end Connector

Item	Description
Applicable wire size	Stranded wires: AWG24-12(0.2~2.5mm ²)
Stripped length	7mm

Gateway R Unit of CC-Link Specification



This communication unit is used to operate the ROBONET via CC-Link.

Model **RGW-CC**

Specification

Item	Specification	Item	Specification				
Power supply	DC24V ±10%	CC-Link specifications	Error control method				
Current consumption	Max. 600 mA		Number of occupied stations	CRC (X ¹⁶ +X ¹² +X ⁵ +1)			
CC-Link specifications	Communication protocol		Remote device station	Communication cable length (*)			
			x1: 4 stations		x4: 2 stations	x8: 2 stations	
		10M/5M/2.5M/625k/156kbps (switchable using dedicated software)	Baud rate (bps)	10M	5M	2.5M	625k
	Broadcast polling method	Total cable length (m)	100	160	400	900	1200
	Frame synchronization method	Communication cable	Dedicated CC-Link cable				
	NRZI	Surrounding air temperature	0~40°C				
	Bus format (conforming to EIA RS485)	Surrounding humidity	95% RH or below (non-condensing)				
	Conforming to HDLC	Operating ambience	Free from corrosive gases, flammable gas, oil mist or powder dust.				
		Environment conditions					
		Protection degree	IP20				
		Weight	140g				
		Accessories	Terminal resistor board (model:TN-1) Network connector/emergency stop connector Terminal resistor cable (110Ω/130Ω)				

*1 Certified
*2 If T-branching communication is to be used, refer to the operation manuals of the master unit and PLC installed in the master unit.

Network Connector

Gateway connector:
MSTBA2.5/5-G-5.08AU
(by Phoenix Contact)

Cable-end connector
MSTB2.5/5-ST-5.08 ABGY AU
(by Phoenix Contact)
= Standard accessory

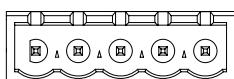

DA DB DG SLD FG

Signal name	Explanation
DA	Communication line A
DB	Communication line B
CG	Ground
SLD	Connect the shield or cable shield. The SLD signal is connected to "FG" and the enclosure.
FG	Frame ground. The FG signal is connected to "SLD" and the enclosure.

Applicable Wire for Cable-end Connector

Item	Description
Applicable wire size	Stranded wires: AWG24-12(0.2~2.5mm ²)
Stripped length	7mm

Gateway R Unit of ProfiBus Specification



This communication unit is used to operate the ROBONET via ProfiBus.

Model **RGW-PR**

Specification

Item	Specification	Item	Specification	
Power supply	DC24V ±10%	Environment conditions	Surrounding air temperature	
Current consumption	Max. 600 mA		Surrounding humidity	
ProfiBus specifications	Communication protocol	DP slave	Operating ambience	
	Baud rate	9.6kbps~12Mbps	Protection degree	
	Communication cable length	9.6kbps	1500m	Weight
		500kbps	400m	Accessories
		1.5Mbps	200m	
3Mbps		200m		
	12Mbps	100m	Terminal resistor board (model:TN-1) Network connector/emergency stop connector	

Network Connector

Gateway connector:
D-sub, 9-pin connector,
socket end

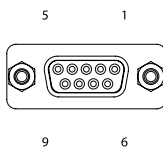

Pin No.	Signal name	Explanation	Pin No.	Signal name	Explanation
3	B-Line	Communication line B (RS485)	6	+5V	+5-V output (insulated)
4	RTS	Request to send	8	A-Line	Communication line A (RS485)
5	GND	Signal ground (insulated)	Housing	Shield	Cable shield. Connected to the enclosure.

* The mating connector (D-sub, 9-pin connector) is not supplied.
* Pins 1, 2, 7 and 9 are not connected.

Gateway R Unit of SIO Specification



This communication unit is used to operate the ROBONET in serial communication from an XSEL controller (*1) or Modbus communication unit.

Model **RGW-SIO**

Specification

Item	Specification	Item	Specification	
SIO specifications	Power supply	DC24V ±10%	Environment conditions	Surrounding air temperature
	Current consumption	Max. 600 mA		Surrounding humidity
	Communication format	Conforming to RS485 (Modbus protocol), 1:1 communication connection	Operating ambience	Free from corrosive gases, flammable gas, oil mist or powder dust.
	Communication method	Asynchronous, half-duplex	Protection degree	IP20
	Baud rate	Max. 230.4 kbps	Weight	140g
	Cable length	100 m or less	Accessories	Terminal resistor board (model:TN-1) Network connector/emergency stop connector
	Recommended cable	Twisted paired cable (shielded) x 2		

Network Connector

Gateway connector:
MC1.5/4-G-3.5
(by Phoenix Contact)

Cable-end connector
MC1.5/4-ST-3.5
(by Phoenix Contact)
= Standard accessory

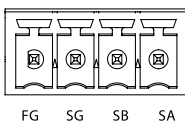

Signal name	Explanation
SA	Communication line A (+) With a built-in terminal resistor (220Ω)
SB	Communication line A (-)
SG	Signal ground
FG	Frame ground. Connected to the enclosure.

Applicable Wire for Cable-end Connector

Item	Description
Applicable wire size	Stranded wires: AWG28-16 (0.14~1.5mm ²)
Stripped length	7mm

RACON Unit: RCA-series Controller



This controller unit is used to operate an RCA actuator in a ROBONET system.

Model **RACON-[1]-[2]**

* Specify the motor wattage in [1] in the model name. (Refer to the table below.)
In [2], specify "ABU" only if you are using the simple absolute unit. (If the simple absolute unit is not used, leave this space blank.)

Model	Applicable actuators
RACON-20-[2]	RCA-SA4□ / SS4□ / SA5□ / SS5□ / RA4□-20 / RG□4□-20 / A4R / A5R RCACR-SA4C / SA5□ RCAW-RA4□-20
RACON-20S-[2]	RCA-RA3□ / RG□3 RCAW-RA3□
RACON-30-[2]	RCA-SA6□ / SS6□ / RA4□-30 / RG□4□-30 / A6R RCACR-SA6□ RCAW-RA4□-30

Specification

Item		Specification	Item		Specification
General specifications	Power supply	DC24V ±10%	Environment conditions	Surrounding air temperature	0~50°C
	Power-supply capacity	Max. 5.1 A (The specific capacity varies depending on the actuator.)		Surrounding humidity	95% RH or below (non-condensing)
	Operated actuator	RCA series		Operating ambience	Free from corrosive gases, flammable gas, oil mist or powder dust.
	Number of positioning points	768		Protection degree	IP20
	Backup memory	EEPROM	Weight	200g	
	Position detection method	Incremental encoder	Accessories	ROBONET communication connection board (model: JB-1), power-supply connection plate (model: PP-1)	
	Forced release of electromagnetic brake	Brake release switch			
	Motor cable	Model CB-ACS-MA□□□			
	Encoder cable	Model CB-ACS-PA□□□			

RPCON Unit: RCP2-series Controller



This controller unit is used to operate an RCP2 actuator in a ROBONET system.

Model **RACON-[1]-[2]**

* Specify the motor type in [1] in the model name. (Refer to the table below.)
In [2], specify "ABU" only if you are using the simple absolute unit. (If the simple absolute unit is not used, leave this space blank.)
* The simple absolute unit cannot be used with the RCP2-RA2C, GRS, RTB and RTC.

Model	Applicable actuators
RPCON-20P	RCP2-RA2C / GRS
RPCON-28P-[2]	RCP2-GRM / GR3LS / GR3SS / RTB / RTC
RPCON-28SP-[2]	RCP2-RA3C / RGD3C
RPCON-42P-[2]	RCP2-SA5□ / SA6□ / SS7□ / BA6□ / BA7□ / RA4C / RG□4C / GR3LM / GR3SM RCP2CR-SA5C / SA6C / SS7C RCP2W-RA4C
RPCON-56P-[2]	RCP2-SA7□ / SS8□ / RA6C / RG□6C / RCP2CR-SA7C / SS8C RCP2W-RA6C

* RCP2 actuators of old types are also supported. (Contact IAI for details.)

Specification

Item		Specification	Item		Specification
General specifications	Power supply	DC24V ±10%	Environment conditions	Surrounding air temperature	0~50°C
	Power-supply capacity	Max. 2 A		Surrounding humidity	95% RH or below (non-condensing)
	Operated actuator	RCP2 series		Operating ambience	Free from corrosive gases, flammable gas, oil mist or powder dust.
	Number of positioning points	768		Protection degree	IP20
	Backup memory	EEPROM	Weight	200g	
	Position detection method	Incremental encoder	Accessories	ROBONET communication connection board (model: JB-1), power-supply connection plate (model: PP-1)	
	Forced release of electromagnetic brake	Brake release switch			
	Motor cable	Model CB-RCP2-MA□□□			
	Encoder cable	Model CB-RCP2-PB□□□			

Explanation of Component Units (Simple Absolute R Unit/Expansion Unit)

Simple absolute R unit



When this data-backup battery unit is connected to an RACON or RPCON (*1), an incremental actuator can be used as an absolute actuator.

*1 One simple absolute R unit is required for one RACON or RPCON unit.

Model **RABU** (RACON/RPCON)

* To order a simple absolute R unit together with a controller unit (RACON/RPCON), specify “-ABU” at the end of the model code of the controller to which the simple absolute R unit will be installed.

Specification

Item		Specification				Item		Specification		
General specifications	Power supply	DC24V ±10%				Environment conditions	Surrounding air temperature	0~40°C		
	Current consumption	Max. 300 mA					Surrounding humidity	95% RH or below (non-condensing)		
	Applicable battery	Ni-MH battery, nickel hydrogen battery					Operating ambience	Free from corrosive gases, flammable gas, oil mist or powder dust.		
	Charge time	Approx. 78 hours					Protection degree	IP20		
	Battery life	3 years				Weight	330g			
	Maximum rotation speed at which absolute data can be backed up (rpm)	800	400	200	100	Accessories	ROBONET communication connection board (model: JB-1), Simple absolute connection board (model: JB-1), power-supply connection plate (model: PP-1)			
	Absolute-data backup time (h)	120	240	360	480					

Example of order



In certain situations, such as when many controllers have been linked to the ROBONET and the system has become too wide to fit the control panel, this unit can be used to fold the controller link by connecting a cable in the middle of the link.

You can also install the expansion unit at the end of the ROBONET link and use an external controller cable to operate an SCON or other standalone controller on the network just like the controller units linked to the ROBONET.

Model **REXT** (RPCON/RACON)

Specification

Item		Specification	
General specifications	Power supply	DC24V ±10%	
	Current consumption	Max. 100 mA	
Environment conditions	Surrounding air temperature	0~40°C	
	Surrounding humidity	95% RH or below (non-condensing)	
	Operating ambience	Free from corrosive gases, flammable gas, oil mist or powder dust.	
	Protection degree	IP20	
Weight	140g		
Accessories	ROBONET communication connection board (model: JB-1), power-supply connection plate (model: PP-1)		

(Note) The cable used when the ROBONET link is folded is different from the one used to connect a standalone controller. For details, refer to the system configuration (ROBONET expansion unit) on P. 117.

External Dimensions

The Gateway R unit, RACON unit, RPCON unit and simple absolute R unit all have the same external dimensions.

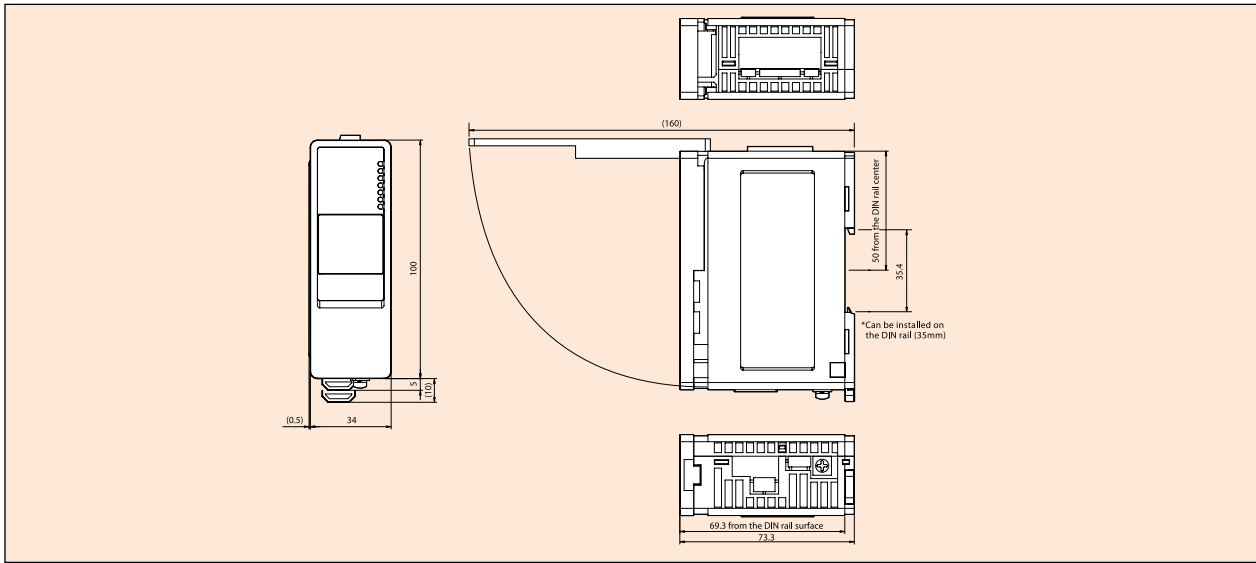

Options



ROBONET communication connection board (simple absolute connection board)
Model JB-1



Terminal resistor board
Model TN-1



Power-supply connection plate
Model PP-1

2-axis
Combinations
R C P 2

2-axis
Combinations
R C S 2

3-axis
Combinations
R C P 2

3-axis
Combinations
R C S 2

Controllers

Model List

PSEL

SSEL

ROBONET

XSEL

Replacement Parts

Motor Cable for RCA

Item **CB-ACS-MA** □ □ □

* □ □ □ indicates the cable length (L). A desired length up to 20 m can be specified.
 Example) 080 = 8 m

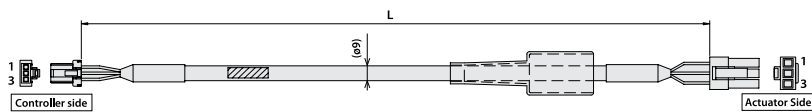

Wire	Color	Signal	No.	No.	Signal	Color	Wire
AWG22 (Press fit)	Red	U	1	1	U	Red	AWG22 (Press fit)
	White	V	2	2	V	White	
	Black	W	3	3	W	Black	

Encoder Cable/Robot Encoder Cable for RCA

Item **CB-ACS-PA** □ □ □ / **CB-ACS-PA** □ □ □ -RB

* The standard encoder cable is a normal cable. A robot cable can be specified as an option.
 * □ □ □ indicates the cable length (L). A desired length up to 20 m can be specified.
 Example) 080 = 8 m

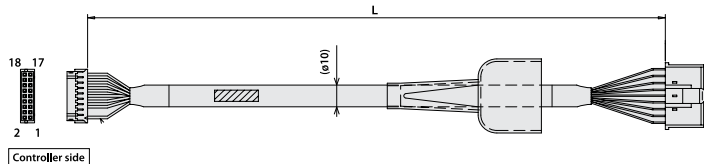

Color	Signal	No.	No.	Signal	Color
Robot Cable	Standard Cable				
White/Purple	Blue	LS+	18	1	ENB
White/Gray	Orange	LS-	17	2	ENR
Yellow	Green	BK+	16	3	ENB
Blue	Brown	BK-	15	4	ENR
White/Blue	Gray	ENA	14	5	-
White/Yellow	Red	ENB	13	6	-
White/Red	Black	ENB	12	7	LS+
White/Black	Yellow	ENB	11	8	-
Orange	Pink	ENZ	10	9	FG
Green	Purple	ENZ	9	10	ENZ
Purple	White	-	8	11	ENZ
Gray	Blue/White	VPS	7	12	-
Red	Orange/White	ZV	6	13	VPS
Black	Green/White	GND	5	14	SV
-	-	-	4	15	GND
-	-	-	3	16	LS-
-	-	-	2	17	BK-
Ground	Ground	E.G.	1	18	BK+

Housing: PHDR-18VR
 Contact: SPHD-001T-P0.5

Flag Housing: XMP-18V
 Socket Contact: BXA-001T-P0.6
 Retainer: XMS-09V

Integrated Motor/Encoder Cable for RCA2

Item **CB-ACS-MPA** □ □ □

* □ □ □ indicates the cable length (L). A desired length up to 20 m can be specified.
 Example) 080 = 8 m

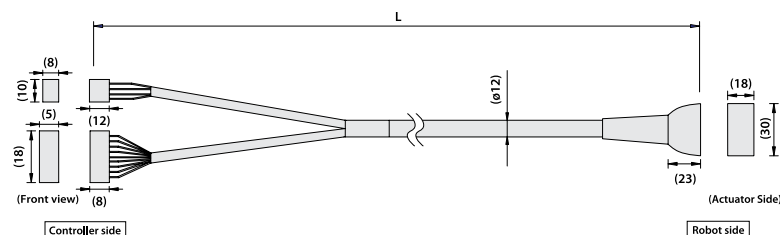

Signal	No.	(Color)	No.	Signal
U	1	Red	A1	U
V	2	Yellow	B1	V
W	3	Black	A2	W
			B2	NC
			A3	NC
			B3	NC
			A4	BK+
			B4	BK-
			A5	LS+
			B5	LS-
			A6	A+
			B6	A-
			A7	B+
			B7	B-
			A8	Z+
			B8	Z-
			A9	-
			B9	/PS
			A10	VCC
			B10	GND
			A11	NC
			B11	FG

Shield

Unit Link Cable for Expansion Unit

Item **CB-REXT-SIO010**

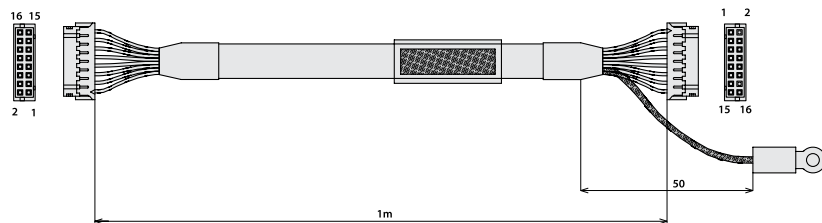

DF11-16DS-2C	No.	Signal name	DF11-16DS-2C	No.	Signal name
/RSV1	16	Black2/White	Black2/White	16	/RSV1
RSV1	15	Red2/White	Red2/White	15	RSV1
/ROUT	14	Black2/Gray	Black2/Gray	14	/ROUT
ROUT	13	Red2/Gray	Red2/Gray	13	ROUT
/RSV0	12	Black2/Orange	Black2/Orange	12	/RSV0
RSV0	11	Red2/Orange	Red2/Orange	11	RSV0
/ENA	10	Black1/Pink	Black1/Pink	10	/ENA
ENA	9	Red1/Pink	Red1/Pink	9	ENA
COM2	8	Black1/Yellow	Black1/Yellow	8	COM2
COM1	7	Red1/Yellow	Red1/Yellow	7	COM1
SD+	6	Black1/White	Black1/White	6	SD-
SD-	5	Red1/White	Red1/White	5	SD+
RD+	4	Black1/Gray	Black1/Gray	4	RD-
RD-	3	Red1/Gray	Red1/Gray	3	RD+
EMG+	2	Black1/Orange	Black1/Orange	2	EMG-
EMG-	1	Red1/Orange	Red1/Orange	1	EMG+

Ground

RAV1.25-3
 - FG

Legend of wire color: Dot color and number of dot(s)/insulator color

Controller Connection Cable for Expansion Unit

Item **CB-REXT-CTL010**

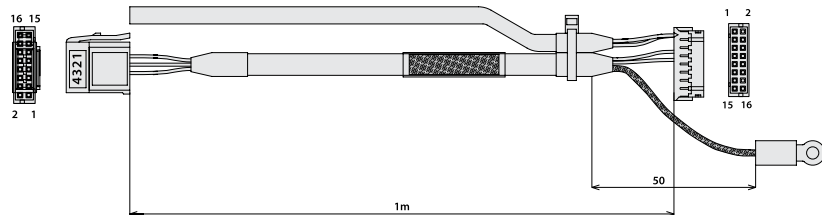

No.	Signal	No.	Signal
4	N.C.	10	/ENA
3	GND	9	ENA
2	SD-	8	COM2
1	SD+	7	COM1
		6	SD-
		5	SD+
		4	RD-
		3	RD+
		2	EMG-
		1	EMG+

Ground

RAV1.25-3
 - FG

Regenerative resistor unit

J (Small Type)/K (General-purpose Type)/KE (CE Type)

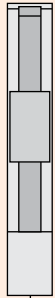

■ Connectable actuators

- High-speed, high-precision type ISPA series
- Standard type ISA series
- Dustproof type ISDA series
- Clean room specification ISDACR series
- Antistatic specification ISDACR ESD
- High-rigidity belt type IF series
- Slim belt type FS series
- Rotational axis RS series
- ROBO Cylinder RCS2 series

■ External devices

- Parts feeder
- Solenoid valve
- PLC

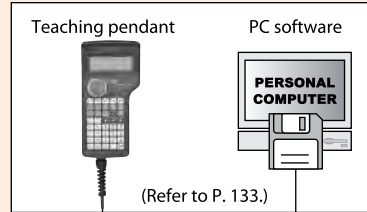

Standard motor cable, 3 m/5 m (Refer to P. 133.)
Standard encoder cable, 3 m/5 m (Refer to P. 134.)
(Supplied with the actuator)

I/O flat cable, 2 m
(Supplied with the controller)
(Refer to P. 134.)

Regeneration unit cable, 1 m
(Supplied with the regeneration unit)

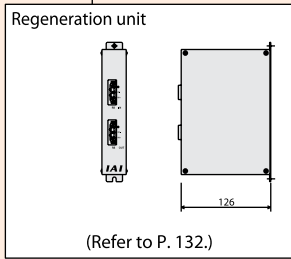

RS232 cable, 5 m (Refer to P. 133.)
(Supplied with the PC software)

■ Main power supply

- Single-phase 100 VAC
- Single-phase 200 VAC

■ I/O power supply

- DC24V

■ System I/Os

- Emergency stop
- Enable
- System ready

■ Various field networks

- Device Net (Refer to P. 132.)
- CC-Link (Refer to P. 132.)
- Profi Bus
- Ethernet

■ Serial communication unit

- Expansion SIO board (Refer to P. 132.)
RS232C/RS422/RS485

P (Large-capacity Type)/Q (Large-capacity Global Type)

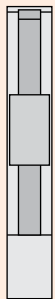

■ Connectable actuators

- High-speed, high-precision type ISPA series
- Standard type ISA series
- Dustproof type ISDA series
- Clean room specification ISDACR series
- Antistatic specification ISDACR ESD
- High-rigidity belt type IF series
- Slim belt type FS series
- Rotational axis RS series
- Linear servo LSA series
- ROBO Cylinder RCS2 series

■ External devices

- PLC, etc.

■ Various field networks

- Device Net
- CC-Link
- Profi Bus
- Ethernet

■ Serial communication port 2 channels of standard and RS232

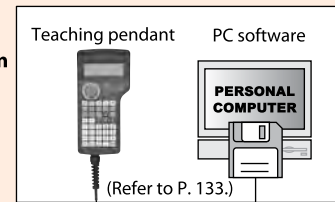

Standard motor cable, 3 m/5 m (Refer to P. 133.)
Standard encoder cable, 3 m/5 m (Refer to P. 134.)
(Supplied with the actuator)

I/O flat cable, 2 m
(Supplied with the controller)
(Refer to P. 134.)

Regeneration unit cable, 1 m
(Supplied with the regeneration unit)

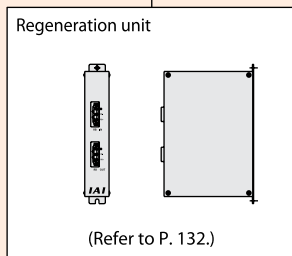

RS232 cable, 5 m (Refer to P. 133.)
(Supplied with the PC software)

■ Control power supply

- Single-phase 200 VAC

■ Motor-drive power supply

- Three-phase 200 VAC (Q type)

■ System I/Os

- Emergency stop
- Enable
- System ready

■ Expansion I/Os

- PIO board
- * If an expansion I/O board is installed on the P or Q type, the controller enclosure will be changed. (Refer to P. 129.)

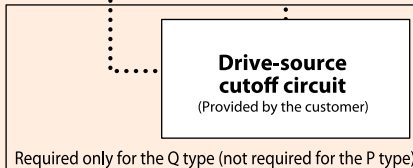

2-axis Combinations R C P 2
 2-axis Combinations R C S 2
 3-axis Combinations R C P 2
 3-axis Combinations R C S 2
 Controllers
 Model List
 PSEL
 SSEL
 ROBOTNET
 XSEL

I/O Wiring

Input External input specifications (NPN specification)

Item	Specification
Input voltage	DC24V ±10%
Input current	7 mA per circuit
ON/OFF voltages	ON voltage --- Min. 16.0VDC / OFF voltage --- Max. 5.0 VDC
Insulation method	Photo-coupler insulation
Externally connected devices	[1] No-voltage contacts (minimum load of approx. 5 VDC/1 mA) [2] Photoelectric/proximity sensors (NPN type) [3] Sequencer transistor outputs (open-collector type) [4] Sequencer contact outputs (minimum load of approx. 5 VDC/1 mA)

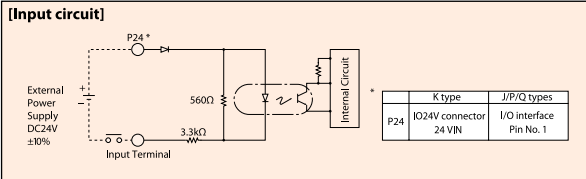

Input External input specifications (PNP specification)

Item	Specification
Input voltage	DC24V ±10%
Input current	7 mA per circuit
ON/OFF voltages	ON voltage --- Min. 8.0 VDC / OFF voltage --- Max. 19.0 VDC
Insulation method	Photo-coupler insulation
Externally connected devices	[1] No-voltage contacts (minimum load of approx. 5 VDC/1 mA) [2] Photoelectric/proximity sensors (PNP type) [3] Sequencer transistor outputs (open-collector type) [4] Sequencer contact outputs (minimum load of approx. 5 VDC/1 mA)

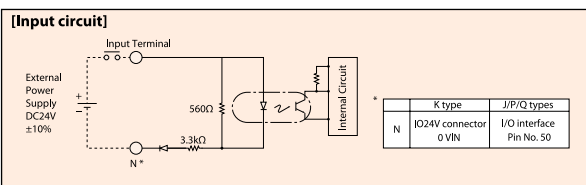

Output External output specifications (NPN specification)

Item	Specification
Load voltage	DC24V
Maximum load current	100 mA per point, 400 mA peak (total current)
Leak current (max.)	Max. 0.1 mA per point
Insulation method	Photo-coupler insulation
Externally connected devices	[1] Miniature relays [2] Sequence input units

TD62084 (or equivalent) is used.

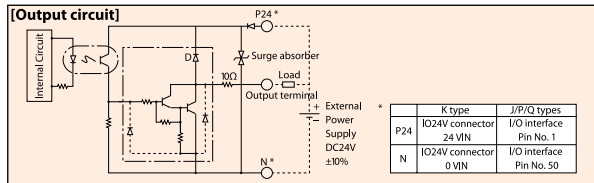

Output External output specifications (PNP specification)

Item	Specification
Load voltage	DC24V
Maximum load current	100 mA per point 400 mA per 8 ports Note)
Leak current (max.)	Max. 0.1 mA per point
Insulation method	Photo-coupler insulation
Externally connected devices	[1] Miniature relays [2] Sequence input units

TD62784 (or equivalent) is used.

Note) The maximum total load current for every eight ports from output port No. 300 is 400 mA. (The maximum total load current of output port Nos. 300+n to 300+n+7 is 400 mA, where n is 0 or a multiple of 8.)

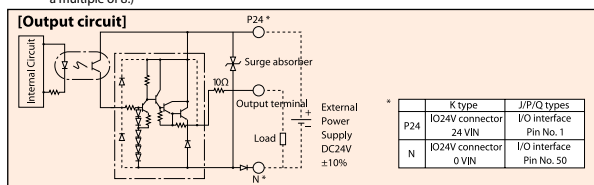

I/O Signal Tables

Standard I/O Signal Table (When N1 or P1 is selected)

Pin No.	Category	Port No.	Standard setting
1		—	I/P/Q types: 24-V connection / K type: NC
2		000	Program start
3		001	General-purpose input
4		002	General-purpose input
5		003	General-purpose input
6		004	General-purpose input
7		005	General-purpose input
8		006	General-purpose input
9		007	Program specification (PRG No. 1)
10		008	Program specification (PRG No. 2)
11		009	Program specification (PRG No. 4)
12		010	Program specification (PRG No. 8)
13		011	Program specification (PRG No. 10)
14		012	Program specification (PRG No. 20)
15		013	Program specification (PRG No. 40)
16	Input	014	General-purpose input
17		015	General-purpose input
18		016	General-purpose input
19		017	General-purpose input
20		018	General-purpose input
21		019	General-purpose input
22		020	General-purpose input
23		021	General-purpose input
24		022	General-purpose input
25		023	General-purpose input
26	024	General-purpose input	
27	025	General-purpose input	
28	026	General-purpose input	
29	027	General-purpose input	
30	028	General-purpose input	
31	029	General-purpose input	
32	030	General-purpose input	
33	031	General-purpose input	
34	Output	300	Alarm output
35		301	Ready output
36		302	Emergency stop output
37		303	General-purpose output
38		304	General-purpose output
39		305	General-purpose output
40		306	General-purpose output
41		307	General-purpose output
42		308	General-purpose output
43		309	General-purpose output
44		310	General-purpose output
45		311	General-purpose output
46		312	General-purpose output
47		313	General-purpose output
48		314	General-purpose output
49		315	General-purpose output
50		—	I/P/Q types: 0-V connection / K type: NC

Expansion I/O Signal Table (When N1 or P1 is selected)

Pin No.	Category	Standard setting
1		I/P/Q types: 24-V connection / K type: NC
2	Input	General-purpose input
3		General-purpose input
4		General-purpose input
5		General-purpose input
6		General-purpose input
7		General-purpose input
8		General-purpose input
9		General-purpose input
10		General-purpose input
11		General-purpose input
12		General-purpose input
13		General-purpose input
14		General-purpose input
15		General-purpose input
16		General-purpose input
17		General-purpose input
18		General-purpose input
19		General-purpose input
20		General-purpose input
21		General-purpose input
22		General-purpose input
23		General-purpose input
24		General-purpose input
25		General-purpose input
26		General-purpose input
27		General-purpose input
28		General-purpose input
29		General-purpose input
30		General-purpose input
31		General-purpose input
32	General-purpose input	
33	General-purpose input	
34	General-purpose output	
35	General-purpose output	
36	General-purpose output	
37	General-purpose output	
38	General-purpose output	
39	General-purpose output	
40	General-purpose output	
41	General-purpose output	
42	General-purpose output	
43	General-purpose output	
44	General-purpose output	
45	General-purpose output	
46	General-purpose output	
47	General-purpose output	
48	General-purpose output	
49	General-purpose output	
50		I/P/Q types: 0-V connection / K type: NC

Expansion I/O Signal Table (When N2 or P2 is selected)

Pin No.	Category	Standard setting
1		I/P/Q types: 24-V connection / K type: NC
2	Input	General-purpose input
3		General-purpose input
4		General-purpose input
5		General-purpose input
6		General-purpose input
7		General-purpose input
8		General-purpose input
9		General-purpose input
10		General-purpose input
11		General-purpose input
12		General-purpose input
13		General-purpose input
14		General-purpose input
15		General-purpose input
16		General-purpose input
17		General-purpose input
18		General-purpose output
19		General-purpose output
20		General-purpose output
21		General-purpose output
22		General-purpose output
23		General-purpose output
24		General-purpose output
25		General-purpose output
26		General-purpose output
27		General-purpose output
28		General-purpose output
29		General-purpose output
30		General-purpose output
31		General-purpose output
32	General-purpose output	
33	General-purpose output	
34	Output	General-purpose output
35		General-purpose output
36		General-purpose output
37		General-purpose output
38		General-purpose output
39		General-purpose output
40		General-purpose output
41		General-purpose output
42		General-purpose output
43		General-purpose output
44		General-purpose output
45		General-purpose output
46		General-purpose output
47		General-purpose output
48		General-purpose output
49		General-purpose output
50		

Specification Table

■ J (Small Type)/K (General-purpose Type)

Item	Description													
Controller series/type	J (small type)						K (general-purpose type)/KE (CE type)							
Connected actuators	RCS2/ISA/ISPA/ISP/ISDA/ISDACR/ISPDACR/IF/FS/RS													
Applicable motor output (W)	20/30/60/100/150/200/300/400/600/750													
Number of connected axes	1	2	3	4	5	6	1	2	3	4	5	6		
Maximum output of connected axes (W)	Max 800 (at power-supply voltage of 200 V) Max 400 (at power-supply voltage of 100 V)						Max 800			Max 1600 (at power-supply voltage of 200 V) Max 800 (at power-supply voltage of 200 V)				
Input power supply	100-V specification: Single-phase 100 to 115 VAC 200-V specification: Single-phase 200 to 230 VAC													
Operating power-supply voltage range	±10%													
Power-supply frequency	50Hz/60Hz													
Power-supply capacity	Max 1670VA		Max 1720VA		Max 1810VA		Max 1670VA		Max 3120VA		Max 3220VA		Max 3310VA	
Position detection method	Incremental encoder (wire-saving type) Multi-rotation data backup absolute encoder (wire-saving type)													
Speed setting	1 mm/sec ~ (The maximum limit varies depending on the actuator.)													
Acceleration setting	0.01 G ~ (The maximum limit varies depending on the actuator.)													
Program language	Super SEL													
Number of programs	64													
Number of program steps	6,000 (total)													
Number of multi-tasking programs	16													
Number of positions	3,000													
Data storage device	Flash ROM + SRAM backup battery													
Data input method	Teaching pendant or PC software													
Standard I/Os	32 points (total of dedicated inputs + general-purpose inputs)/16 points (total of dedicated outputs + general-purpose outputs)													
Expansion I/Os	None			1 unit, 48 points (1 unit can be added)			1 unit, 48 points (Up to 3 units can be added)							
Serial communication function	Standard RS232 port (D-sub, 25-pin)						Standard RS232 port + Expansion SIO board (optional)							
Other I/Os	System I/Os (emergency stop input, enable input, system ready output)													
Protective functions	Motor overcurrent, overload, motor/driver temperature check, overload check, encoder open detection, soft limit overtravel, system error, battery error, etc.													
Surrounding air temperature/humidity	Temperature 0 to 40°C, humidity 30 to 85%													
Surrounding ambience	Free from corrosive gases or significant dust.													
Weight	2.6kg		3.3kg		5.0kg		6.0kg		7.0kg					
Accessory	I/O flat cable													

■ P (Large-capacity Type)/Q (Large-capacity Type Conforming to Safety Category)

Item	Description															
Controller series/type	P (standard) type						Q (global) type									
Connected actuators	RCS2/ISA/ISPA/ISP/ISDA/ISDACR/ISPDACR/IF/FS/RS/LSA															
Applicable motor output	20/30/60/100/150/200/300/400/600/750															
Number of controlled axes	1	2	3	4	5	6	1	2	3	4	5	6				
Maximum output of connected axes (W)	Max2400W (1600 W for single-phase 200-VAC specification)															
Control power input	AC 200/230, single-phase -15%, +10%						AC 200/230, single-phase -15%, +10%									
Motor power input	AC 200/230, single-phase/three-phase -10%, +10%						AC 200/230, single-phase/three-phase -10%, +10%									
Power-supply frequency	50/60Hz															
Insulation resistance	10MΩ or more (at 500 VDC, between the power-supply terminal and each I/O terminal and between all external terminals and the case)															
Withstand voltage	1500 VAC (1 minute)						1500 VAC (1 minute)									
Power-supply capacity (*1)	Max 1744VA	Max 3266VA	Max 4787VA	Max 4878VA	Max 4931VA	Max 4998VA	Max 1744VA	Max 3266VA	Max 4787VA	Max 4878VA	Max 4931VA	Max 4998VA				
Position detection method	Incremental encoder (wire-saving type) Multi-rotation data backup absolute encoder (wire-saving type)															
Safety circuit configuration	Redundancy not supported						Redundancy supported									
Drive-source cutoff method	Internal cutoff relay						External safety circuit									
Enable input	Contact B input (power supplied internally)						Contact B input (power supplied externally, redundant)									
Speed setting	1 mm/sec ~ (The maximum limit varies depending on the actuator.)															
Acceleration setting	0.01 G ~ (The maximum limit varies depending on the actuator.)															
Program language	Super SEL															
Number of programs	64															
Number of program steps	6,000 (total)															
Number of multi-tasking programs	16															
Number of positions	4,000 (total)															
Data storage device	Flash ROM + SRAM backup battery															
Data input method	Teaching pendant or PC															
Standard I/Os	1 of PIO board with 48 I/O points (NPN/PNP) or PIO board with 96 I/O points (NPN/PNP) can be installed.															
Expansion I/Os	Up to 3 of PIO board with 48 I/O points (NPN/PNP) and/or PIO board with 96 I/O points (NPN/PNP) can be installed.															
Serial communication function	Standard teaching port (D-sub, 25-pin) + 2-channel RS232C port (D-sub, 9-pin x 2)															
Protective functions	Motor overcurrent, overload, motor/driver temperature check, overload check, encoder open detection, soft limit overtravel, system error, battery error															
Surrounding air temperature/humidity, ambience	0 to 40°C, 10 to 95% (non-condensing); free from corrosive gases or significant dust.															
Weight (*2)	5.2kg				5.7kg				4.5kg				5kg			
Accessory	I/O flat cable															

*1 When axes corresponding to the maximum wattage are connected.

*2 Including the absolute battery, brake mechanism and expansion I/O box.

External Dimensions

■ J (Small Type)/K (General-purpose Type)

	1-axis specification	2-axis specification	3/4-axis specification	Side view
J type (Small type)				
K type (General-purpose type)	1/2-axis specification 	3/4-axis specification 		

■ P (Large-capacity Standard Type)/Q (Large-capacity Global Type)

The shapes and dimensions of SEL-P/Q types vary depending on the controller specifications (encoder type, with/without brake, and with/without I/O expansion).

The following four shapes are available. Check the applicable dimensions based on the desired type and number of axes to be connected.

		Base shape (incremental specification)	With brake/absolute unit	With I/O expansion base	With brake/absolute unit + I/O expansion base	Side view
Controller specification	Encoder	Incremental	Absolute	Incremental	Absolute	
	Brake	Not equipped	Equipped	Not equipped	Equipped	
	I/O	Standard only	Standard only	Standard + Expansion	Standard + Expansion	
P type (Large-capacity)	1 to 4-axis specification					
	5 to 6-axis specification					
Q type (Large capacity conforming to safety standard) <small>* The dimensions of single phase 200VAC controllers conform to those of the P type.</small>	1 to 4-axis specification					
	5 to 6-axis specification					

Name of Each Part

J Type (Small)

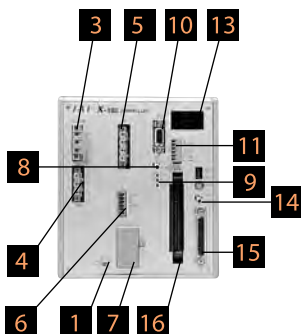

K Type (General-purpose)

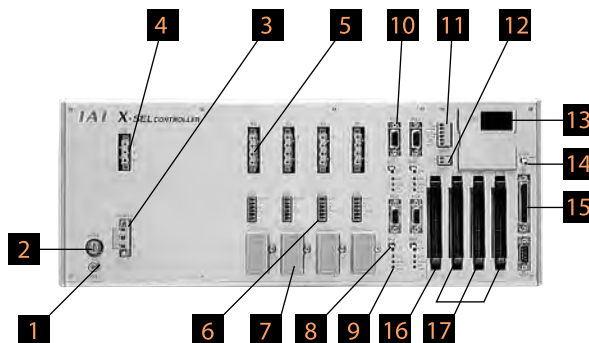

1 FG connection terminal

A connection edge to connect the FG terminal of the enclosure. This terminal is connected to the PE terminal of the AC input part internally through the controller.

2 Fuse holder (K type only)

A half-cut fuse holder for protecting the AC input part from overcurrent.

3 Main-power input connector

A connector for 100/200-VAC single-phase input. (This connector comes with a cable-end plug. Refer to the right page.)

4 Regenerative-resistor unit connector

This connector is used to connect the regenerative resistor unit (optional: REU-1) that may be required if the built-in regenerative connector is not enough due to high acceleration, high load, etc.

5 Motor cable connector

A connector for the motor power cable of the actuator motor.

6 Actuator-sensor input connector

A connector for the LS, CREEP, OT and other axis sensors.

7 Absolute-data backup battery

A battery unit for backing up the absolute encoder if used. This battery is not connected to non-absolute axes.

8 Brake release switch (brake specification only)

An alternate switch with lock for releasing the axis brake. To operate this switch, pull the switch toward you and then tilt it to a desired position. Tilt the switch to the top (RLS) position to forcibly release the brake, or tilt it to the bottom (NOM) position to let the controller control the brake automatically.

9 Axis-driver status LEDs

These LEDs are used to monitor the operating status of the driver CPU that controls the motor drive. The following three LEDs are provided.

Name	Color	Meaning when the LED is lit
ALM	Orange	The driver has detected an error.
SVON	Green	The servo is ON and the motor is being driven.
BATT ALM	Orange	The absolute battery voltage is low.

10 Encoder cable connector

This 15-pin, D-sub connector is used to connect the encoder cable of the actuator.

11 System IO connector

This connector has a total of three I/Os including two inputs for controlling the controller operation and one output regarding the system status. (This connector comes with a cable-end plug. Refer to the right page.)

Name		
EMG	Emergency stop input	Operation is enabled when this signal is ON. An emergency stop is actuated when the signal turns OFF.
ENB	Safety gate input	Operation is enabled when this signal is ON. The servo turns OFF when the signal turns OFF.
RDY	System ready relay output	The controller status is output. Cascade connection is supported. The controller is ready when the output contacts are shorted and not ready when the contacts are open.

12 IO24V power connector (K type only)

If DI/DOs are installed in the IO slots 16, 17, this connector is used to supply the I/O power to the insulated part externally.

13 Panel window

The 4-digit 7-segment LED display and five LED lamps indicating the system status can be visually checked.

14 Mode switch

An alternate switch with lock for specifying the operation mode of the controller. To operate this switch, pull the switch toward you and then tilt it to a desired position. The top position indicates the MANU (manual operation) mode, while the bottom position indicates the AUTO (auto operation) mode. Teaching operation can only be performed in the MANU mode, and auto operation using external IOs cannot be performed in the MANU mode.

15 Teaching connector

This D-sub, 25-pin connector is used to connect a teaching pendant or PC to input program positions.

16 Standard I/O slot (slot 1)

The standard PIO board with 32 input points and 16 output points is installed in this slot.

17 Expansion I/O slots (slot 2, slot 3, slot 4)

An expansion IO board (optional) can be installed in each of these slots.

2-axis
Combinations
R C P 2

2-axis
Combinations
R C S 2

3-axis
Combinations
R C P 2

3-axis
Combinations
R C S 2

Controllers

Model
List

PSEL

SSEL

ROBONET

XSEL

P type (standard, 4-axis)

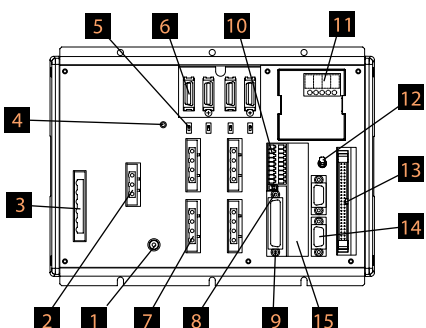

Q type (with absolute brake unit + expansion base, 6-axis)

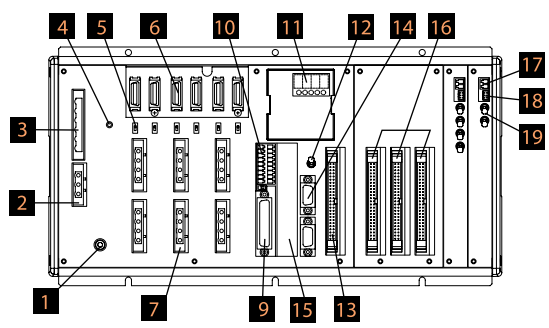

1 FG connection terminal

A connection edge to connect the FG terminal of the enclosure. This terminal is connected to the PE terminal of the AC input part internally through the controller.

2 External regeneration unit connector

This connector is used to connect an additional regenerative resistor when the built-in regenerative resistor is not enough due to high acceleration, high load, etc. Whether or not an external regenerative resistor is needed depends on the specifics of the application, such as the axis configuration.

3 AC-power input connector

A connector for 200-VAC three-phase input. This connector consists of six terminals including the motor power-supply, control power-supply and PE terminals.

The standard specification only comes with a terminal block.
Caution To prevent electric shock, do not touch this connector while the power is supplied.

4 Control power-supply monitor LED

A green light is lit while the control power supply is generating the internal controller power properly.

5 Absolute-battery enable/disable switch

This switch is used to enable or disable the encoder backup operation using the absolute battery. The factory setting is to disable the backup. Connect the encoder and axes-sensor cables, turn on the power, and then set this switch to the top position.

6 Encoder/axis-sensor connector

A connector for the actuator encoder and axis sensors such as LS, CREEP and OT. *: LS, CREEP and OT sensors are optional.

7 Motor connector

A connector for driving the motor in the actuator.

8 Teaching-pendant type selector switch

This switch is used to change the type of the teaching pendant connected to the teaching connector **9**. You can switch between IAI's standard teaching pendant and ANSI teaching pendant. Set the switch provided on the front side of the board according to the teaching pendant to be used.

9 Teaching connector

This teaching interface is used to connect IAI's teaching pendant or PC (PC software) to operate, set or otherwise manipulate the system.

10 System I/O connector

This I/O connector controls the safety operations of the controller. With the global specification, this connector can be used, together with an external safety circuit, to configure a safety circuit meeting up to category 4.

11 Panel window

The panel window consists of the 4-digit, 7-segment LED display and five LED lamps indicating the status of the system.

Meanings of 5 LEDs

Name	Condition when the LED is lit
RDY	The CPU is ready (to perform program operation).
ALM	A CPU alarm (system-shutdown level error) or CPU hardware error is present.
EMG	An emergency stop is actuated or CPU hardware error or power-supply hardware error is present.
PSE	A power-supply hardware error is present.
CLK	The system clock is abnormal.

12 Mode switch

An alternate switch with lock for specifying the operation mode of the controller. To operate this switch, pull the switch toward you and then tilt it to a desired position. The top position indicates the MANU (manual operation) mode, while the bottom position indicates the AUTO (auto operation) mode. Teaching operation can only be performed in the MANU mode, and auto operation using external I/Os cannot be performed in the MANU mode.

13 Standard I/O connector

Overview of standard IO interface specifications

Item	Photo-coupler
Connector name	I/O
Applicable connector	Flat connector, 50-pins
Power supply	Power is supplied from connector pin Nos. 1 and 50.
Inputs	32 points (including general-purpose and dedicated inputs)
Outputs	16 points (including general-purpose and dedicated outputs)
Connected to	External PLC, sensor, etc.

14 General-purpose RS232C port connector

This port is used to connect general-purpose RS232C devices. (Two channels are provided.)

15 Field-network board slot

A fieldbus interface module is installed in this slot.

16 Expansion I/O boards (optional)

Optional expansion boards are installed in these slots.

17 Brake-power input connector

A power input connector for driving the brake of the actuator. 24 VDC must be supplied externally. If the specified power is not supplied, the actuator brake cannot be released. Be sure to supply this power to axes with brake. For the brake power cable, use a shielded cable and connect the shield on the 24-V power supply side.

18 Brake-release switch connector

This connector is used to connect a switch that releases the actuator brake from outside the controller. The brake is released when the COM and BKMRL* terminals of this connector are shorted. Use this connector if you want to manually operate the actuator when the controller power is cut off or other abnormality is present.

19 Brake switch

An alternate switch with lock for releasing the axis brake. To operate this switch, pull the switch toward you and then tilt it to a desired position. Tilt the switch to the top (RLS) position to forcibly release the brake, or tilt it to the bottom (NOM) position to let the controller control the brake automatically.

Options

Regenerative Resistor Unit

Model **REU-1**

Description

This unit converts to heat the regenerative current produced when the motor decelerates. Although the controller has a built-in regenerative resistor, a regeneration unit or units may be required if its capacity is not enough for the vertical axis load. (Refer to the table on the right.)

Specification

Item	Specification
Dimensions	W34mm×H195mm×D126mm
Weight	0.9kg
Built-in regenerative resistor	220Ω 80W
Accessory	Controller connection cable (model: CB-ST-REU101), 1 m

Installation Standards Determine the required number of unit(s) according to the total motor capacity of the connected vertical axes.

Horizontal application

Motor wattage	P/Q type	J type	K type
~200W	Not required	Not required	Not required
~800W	1 unit	Not required	Not required
~1000W	1 unit	-	Not required
~1500W	2 units	-	Not required
~2000W	3 units	-	-
~2400W	4 units	-	-

Vertical application

Motor wattage	P/Q type	J type	K type
~100W	Not required	Not required	Not required
~200W	1 unit	Not required	Not required
~400W	1 unit	1 unit	Not required
~600W	1 unit	1 unit	1 unit
~800W	1 unit	2 units	1 unit
~1200W	2 units	-	2 units
~1600W	3 units	-	Consult IAI.
~2000W	4 units	-	-
~2400W	5 units	-	-

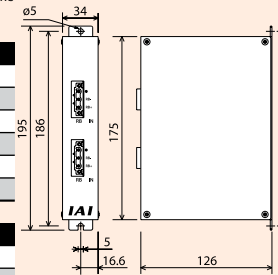

Absolute-data Backup Battery (for XSEL-J/K/KE/KT/KET)

Model **IA-XAB-BT**

Features A data backup battery for absolute axes. Replace the battery as soon as the controller generates a battery alarm.

Packing specification

Individually packed. (One battery is required for one axis. Specify an appropriate quantity according to the number of axes to be used.)



Expansion SIO Board (for General-purpose Type Only)

Model Specification

IA-105-X-MW-A (for RS232C connection) (board + joint cable [1] x 2)
 IA-105-X-MW-B (for RS422 connection) (board + joint cable [2] x 1)
 IA-105-X-MW-C (for RS485 connection) (board + joint cable [2] x 1)

Description

This board is used to perform serial communication with external devices. The 2-channel port supports three communication patterns according to the supplied joint cable.

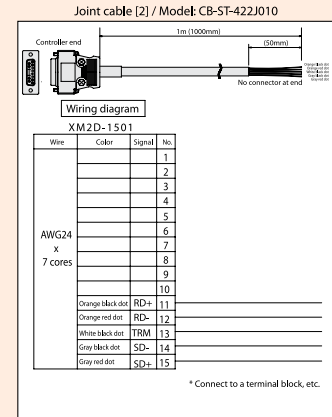
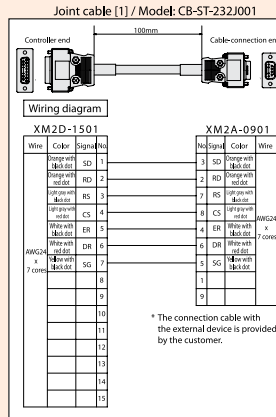

Absolute-data Backup Battery

Model **AB-5**

Features This absolute-data backup battery is used when absolute actuators are operated.



Expansion PIO Board

Description

This optional board is used to add I/Os (inputs/outputs). On the general-purpose and large-capacity types, up to three expansion PIO boards can be installed in the expansion slots. (On the small type, only one expansion PIO board can be installed in the expansion slot, provided that the controller is of 3 or 4-axis type.)

DeviceNet Connection Board

This board is used to connect the XSEL controller to DeviceNet.

Item	Specification			
Number of I/O points	256 input points/256 output points per board * Only one board can be installed.			
Communication protocol	Certified DeviceNet 2.0 interface module (Certification pending)			
	Group 2 only server			
Communication specification	Insulation node of network-power operation type			
	Master-slave connection	Bit strobe		
		Polling		
Cyclic				
Baud rate	500k/250k/125kbps (Switchable via DIP switches)			
Communication cable length	Baud rate	Maximum network length	Maximum branch length	Total branch length
	500kbps	100m	6m	39m
	250kbps	250m		78m
	125kbps	500m		156m
Note) When a thick DeviceNet cable is used.				
Communication power supply	24 VDC (supplied from DeviceNet)			
Current consumption of communication power supply	60 mA or more			
Number of occupied stations	1 node			
Connector	MSTBA2.5/5-G.08AUM by Phoenix Contact (*1)			

(*1) The cable-end connector (SMSTB2.5/5-ST-5.08AU by Phoenix Contact) is a standard accessory.

CC-Link Connection Board

This board is used to connect the XSEL controller to CC-Link.

Item	Specification					
Number of I/O points	256 input points/256 output points per board * Only one board can be installed.					
Communication protocol	CC-Link Ver.1.10 (Certified)					
Baud rate	10M/5M/2.5M/625k/156kbps (switchable via a rotary switch)					
Communication method	Broadcast polling method					
Synchronization method	Frame synchronization method					
Encoding method	NRZI					
Transmission path format	Bus format (conforming to EIA RS485)					
Transmission format	Conforming to HDLC					
Error control method	CRC(X ¹⁶ +X ¹² +X ⁵ +1)					
Number of occupied stations	1 to 3 stations (remote device stations)					
Communication cable length	Baud rate (bps)	10M	5M	2.5M	625k	156k
	Cable length (m)	100	160	400	900	1200
Connector (controller end)	MSTBA2.5/5-G.08AUM by Phoenix Contact (*1)					

(*1) The cable-end connector (SMSTB2.5/5-ST-5.08AU by Phoenix Contact) is a standard accessory.

2-axis Combinations RCP2

2-axis Combinations RCS2

3-axis Combinations RCP2

3-axis Combinations RCS2

Controllers

Model List

PSEL

SSEL

ROBONET

XSEL

Options

Teaching Pendant

Features A teaching device offering functions for program/position input, test operation, monitoring, and more.

Model/Price

Model	Description
SEL-T	Standard type with connector conversion cable
SEL-TD	Deadman switch type with connector conversion cable

Configuration

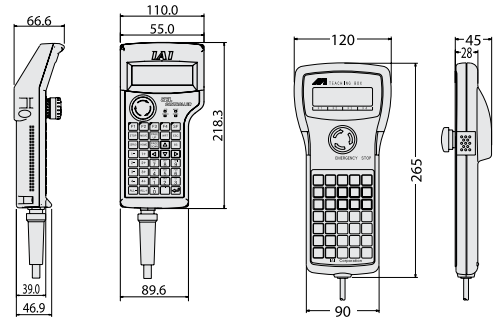
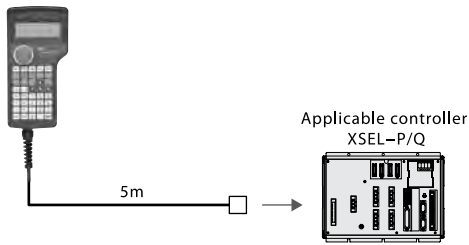

Specification

Item	SEL-T-J	SEL-TD-J
3-position enable switch	Not equipped	Equipped
ANSI/UL standard	Not compliant	Compliant
CE mark	Compliant	
Display	20 characters x 4 lines	
Surrounding air temperature/humidity	0-40°C 10-90%RH (non-condensing)	
Protection structure	IP54	
Weight	Approx. 0.4 kg (excluding cables)	

PC Software (Windows only)

Features A software program that assists the initial startup of your system, offering functions for program/position input, test operation, monitoring, and more. The enhanced debugging functions help reduce the startup time.

Model IA-101-X-MW (with RS232C cable)

Configuration

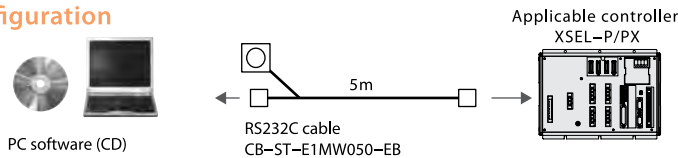

Model IA-101-XA-MW (with safety category 4 cable)

Configuration

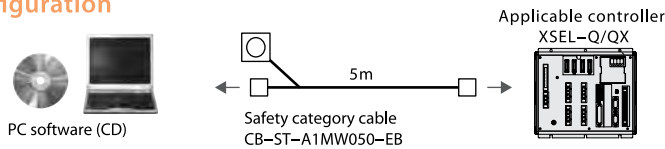

Model IA-101-X-USBMW (with USB conversion adapter + cable)

Configuration

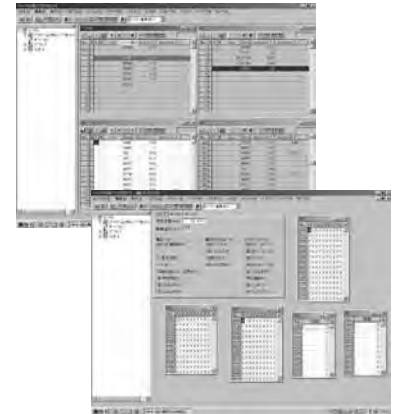
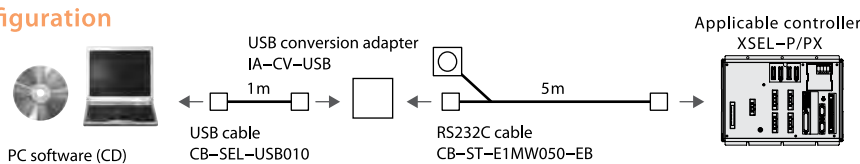

Replacement Parts

If you must order a replacement cable, etc., after the initial purchase of your product, specify the correct model by referring to the information below.

Motor Cable/Robot Motor Cable

Item **CB-RCC-MA** / **CB-RCC-MA** -RB

* [] indicates the cable length (L). A desired length up to 20 m can be specified. Example) 080 = 8 m

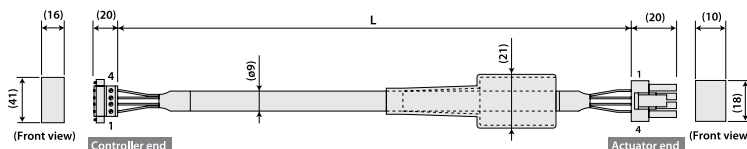

Signal	No.	No.	Signal	Wire
PE	1	1	U	0.75sq (crimped)
U	2	2	V	
V	3	3	W	
W	4	4	PE	

Replacement Parts

Encoder Cable/Robot Encoder Cable (for XSEL-J/K types)

Item **CB-RCBC-PA** [] [] [] / **CB-RCBC-PA** [] [] [] -**RB**

* [] [] [] indicates the cable length (L). A desired length up to 15 m can be specified. Example) 080 = 8 m

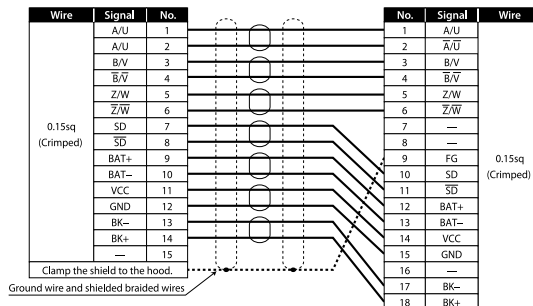
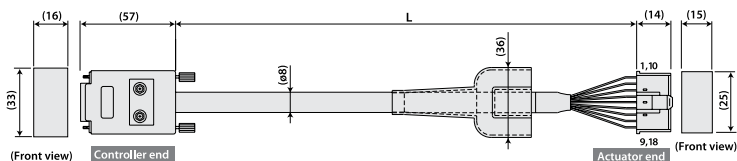

Encoder Cable/Robot Encoder Cable (for XSEL-P/Q types)

Item **CB-RCS2-PA** [] [] [] / **CB-X3-PA** [] [] []

* [] [] [] indicates the cable length (L). A desired length up to 20 m can be specified. Example) 080 = 8 m

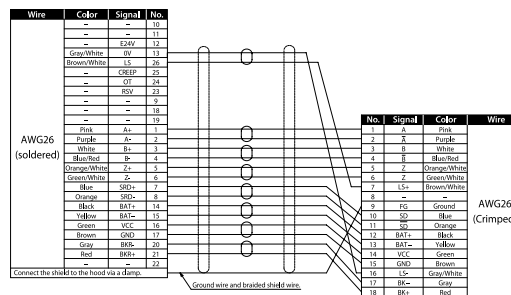
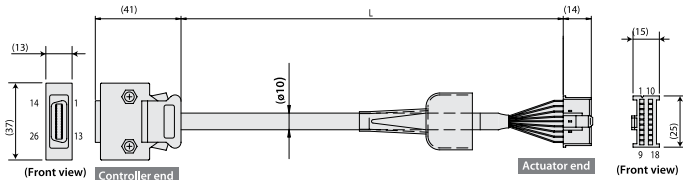

Dedicated Encoder Cable/Robot Encoder Cable for Rotary Robots

Item **CB-RCS2-PLA** [] [] [] / **CB-X2-PLA** [] [] []

* [] [] [] indicates the cable length (L). A desired length up to 30 m can be specified. Example) 080 = 8 m

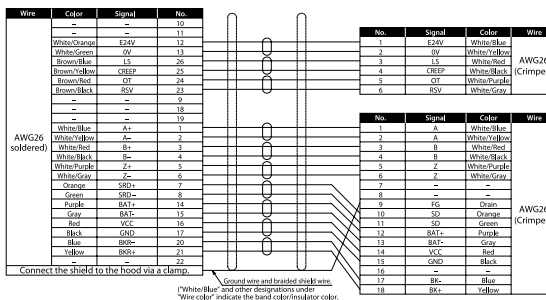
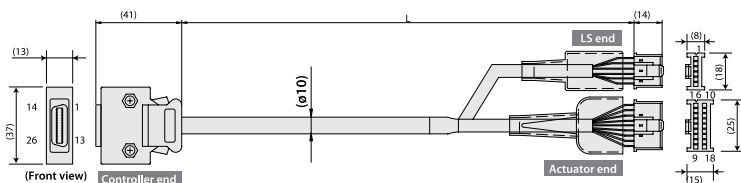

Limit Switch Cable (for X-SEL-J/K types)

Item **CB-X-LC** [] [] []

* [] [] [] indicates the cable length (L). A desired length up to 20 m can be specified. Example) 080 = 8 m

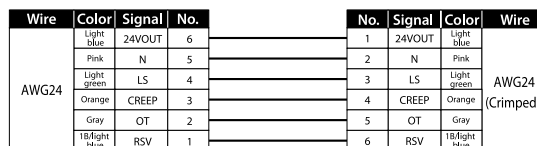
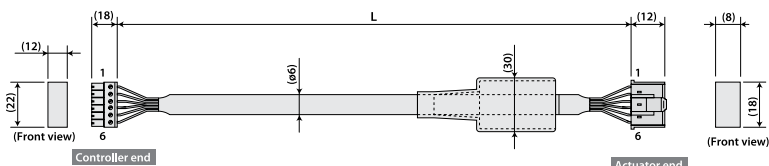

I/O Flat Cable (XSEL-J/K/P/Q types)

Item **CB-X-PIO** [] [] []

* [] [] [] indicates the cable length (L). A desired length up to 10 m can be specified. Example) 080 = 8 m

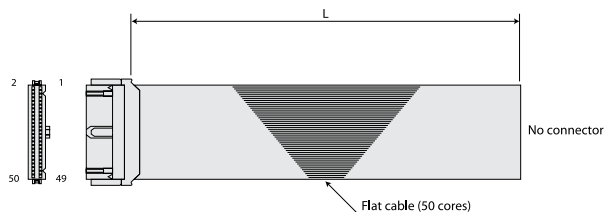

No.	Color	Wire	No.	Color	Wire	No.	Color	Wire
1	Brown 1	Flat cable pressure-welded	18	Gray 2	Flat cable pressure-welded	35	Green 4	Flat cable pressure-welded
2	Red 1		19	White 2		36	Blue 4	
3	Orange 1		20	Black 2		37	Purple 4	
4	Yellow 1		21	Brown-3		38	Gray 4	
5	Green 1		22	Red 3		39	White 4	
6	Blue 1		23	Orange 3		40	Black 4	
7	Purple 1		24	Yellow 3		41	Brown-5	
8	Gray 1		25	Green 3		42	Red 5	
9	White 1		26	Blue 3		43	Orange 5	
10	Black 1		27	Purple 3		44	Yellow 5	
11	Brown-2		28	Gray 3		45	Green 5	
12	Red 2		29	White 3		46	Blue 5	
13	Orange 2		30	Black 3		47	Purple 5	
14	Yellow 2		31	Brown-4		48	Gray 5	
15	Green 2		32	Red 4		49	White 5	
16	Blue 2		33	Orange 4		50	Black 5	
17	Purple 2		34	Yellow 4				



America

USA



IAI America, Inc.

● USA Headquarters & Western Region

2690 W. 237th Street, Torrance, CA 90505

TEL 310-891-6015 FAX 310-891-0815

E-mail info@iaius.com

URL www.intelligentactuator.com

● Midwest Branch Office

1261 Hamilton Parkway, Itasca, IL 60143

TEL 630-467-9900 FAX 630-467-9912

E-mail sales@iaius.com

● GA Branch Office

1220 Kenneston Circle, Suite 108, Marietta, GA30066

TEL 678-354-9470 FAX 678-354-9471



Brazil

CBD Mecanica Industrial Ltda.

Brazil



CBD Mecañica Industrial Ltda.

Rua José Tanoeiro, 261-Vila Monte Sion-08613-123-Suzano-São Paulo-Brazil

TEL 55-11-4748-4501 FAX 55-11-4748-4692



Europe

IAI Industrieroboter GmbH

Germany/Europe



IAI Industrieroboter GmbH

Ober der Röth 4, D-65824 Schwalbach am Taunus, Germany

TEL +49 (0) 6196-88950 FAX +49 (0) 6196-889524

E-mail info@iai-gmbh.de

URL www.iai-gmbh.de



Japanese support



Technical support



Goods stock



Simple repair



Broader-based support

Korea



IA KOREA CORP

4F, SeYoung Bldg 228-1, Poi-Dong, Kangnam-Ku, Seoul, Korea 135-260

TEL 2-578-3523

FAX 2-578-3526

URL www.iakorea.co.kr

China



IAI (SHANGHAI) CO., LTD

SHANGHAI JIAHUA BUSINESS CENTER A8404, 808, Hongqiao Rd. Shanghai 200030, China

TEL 021-6448-4753

FAX 021-6448-3992

E-mail shanghai@iai-robot.com

China



Dalian

FENG TAI COMMERCIAL TRADE CO., LTD.
Room 403, No. 43, Fushun Street, Dalian Development Zone, Dalian 116600 China.

TEL 0411-8762-2104,
8761-6642, 8761-0403
FAX 0411-8762-4677

Beijing

FENG TAI COMMERCIAL TRADE CO., LTD
Room 4-A-706, Hou Xian Dai Building, Bai Zi Wan Road, Chao Yang District, Bei Jing, China.

TEL 010-8776-6989
FAX 010-8776-6975

Tianjin

FENG TAI COMMERCIAL TRADE CO., LTD
Room 3-8-503, Hong Ji Apartment, Jin Wei Road, HeBei District, Tian Jin, China.

TEL 022-2626-5057
FAX 022-2626-1309

Jinan

FENG TAI COMMERCIAL TRADE CO., LTD
Room 15-3-102, No.399 Hua Long Road, Ji Nan City, Shan Dong, China.

TEL 0531-8633-0345
FAX 0531-8633-0348

Shanghai

FEDERAL WORLD WIDE (SHANGHAI) CO., LTD
B/19F Building Huijia No. 37, Cao Xi N Rd, Shanghai 200030, China.

TEL 021-5490-0290
FAX 021-5490-0314

Suzhou

FEDER WORLD-WIDE (S.H) CO., LTD
Room.204, Building2, No.3 Xiang Xue Hai Rd, Su Zhou City, Jiang Su, China.

TEL 0512-6552-9859
FAX 0512-6532-5672

Kunshan

FEDER WORLD WIDE (S+H) CO., LTD.
Room.101, Building 1, No.2, Jin Yang Garden, Xin Zha Rd, Kunsha City, Jiang Su, China

TEL 0512-5739-3766
FAX 0512-5739-5320

Guangzhou

FEDERAL WORLD WIDE (GUANGZHOU) TRADING CO., LTD.
Room 1701, Yian Plaza No. 33, Jian She Lu Ma Road, Yuexiu Distgrect Guang Zhou 510060, China.

TEL 020-8363-3200
FAX 020-8363-3705

Shenzhen

FEDERAL WORLD-WIDE TRADING CO., LTD.
Room B 19/F Block West Shun Tian Plaza, 62 Gui Miao Road, Nan Shan District, Shenzhen, China.

TEL 0755-26475242
FAX 0755-26475177

Dongguan

FEDERAL WORLD-WIDE (GUANGZHOU) TRADING CO., LTD.
Room L2 / F Hao Jing Ting, Jing Jiang Gargen, Jin Xing Rd, Jin Xia Village, Changan Town, Dong Guan, China.

TEL 0769-8539-0221
FAX 0769-8539-0170

Dongguan

AimX Automation Equipment Co., Ltd
Unit 01, 2F, Nanbo Commerce Plaza, Z hangmutou Town, Dongguan City, Guangdong Province, China.

TEL 0769-87790095
FAX 0769-87788795

Jianghai

FEDERAL WORLD WIDE (H+K) CO., LTD.
Zhu Hai Shi, Xiang Zhou Qu, Cui Hua Lu 22#, Cai Yuan Hua Yuan 1 Dong 1303#

TEL 0756-221-8650
FAX 0756-221-8670

Hong Kong

FEDERAL WORLD WIDE CO., LTD.
Unit 2-3, 7/F, International Plaza 20 Sheung Yuet Rd., Kowloon Bay, Kowloon, HK.

TEL 0852-2305-3088
FAX 0852-2305-3113

Asia

IAI
Peking
Dalian
Tianjin
Jinan
Suzhou
Shanghai

ALTEKS CO.,LTD

Guang Zhou
Dongguan
Shenzhen
FEDERAL WORLD WIDE CO.,LTD

SUS BANGKOK CO.

ITC SYSTEMS SDN BHD
INTELLIGENT ACTUATORS SYSTEMS SINGAPORE PTE LTD.

Thailand



System Upgrade Solution Bkk Co., Ltd.

50 GMM Grammy Place 14th Fl., Room #B7, Sukhumvit 21 (Asoke) Rd., Klongtoeynu, Wattana Bangkok 10110 Thailand

TEL 02-259-0547

FAX 02-261-2813

Taiwan



ALTEKS CO.,LTD

5F, 580, Sec. 1, Min-Sheng N Rd., Kuei-Shan Hsiang, Taoyuan Hsien, Taiwan R.O.C.

TEL 3-2121020

FAX 3-2121250

URL www.alteks.com.tw

Malaysia



ITC SYSTEMS SDN BHD

B-901, 9th Fl., Block B, Phileo Damansara II, 15, Jalan 16/11, Off Jln Damansara, 46350 Petaling Jaya, Malaysia

TEL 603-7547386

FAX 603-7547336

Singapore/Philippines/Indonesia/India



INTELLIGENT ACTUATORS SYSTEMS SINGAPORE PTE LTD.

19 Tannery Road Singapore 347730

TEL 6842-4348

FAX 6842-3646

[A]

AB-5	(System-memory backup battery)	101 • 111
AB-5	(Absolute-data backup battery)	111 • 132
AB-5-CS	(System-memory backup battery)	101 • 111

[C]

CB-ACS-MA□□□□	(•able)	124
CB-ACS-MPA□□□□	(Cable)	124
CB-ACS-PA□□□□	(Cable)	124
CB-ACS-PA□□□□-RB	(Cable)	124
CB-DS-PIO□□□□	(Cable)	102 • 112
CB-PCS-MPA□□□□	(Cable)	102 • 123
CB-RCBC-PA□□□□	(Cable)	134
CB-RCBC-PA□□□□-RB	(Cable)	134
CB-RCC-MA□□□□	(Cable)	112 • 133
CB-RCC-MA□□□□-RB	(Cable)	112 • 133
CB-RCP2-MA□□□□	(Cable)	102 • 123
CB-RCP2-PB□□□□	(Cable)	123
CB-RCP2-PB□□□□-RB	(Cable)	123
CB-RCP2-PB□□□□	(Cable)	102
CB-RCP2-PB□□□□-RB	(Cable)	102
CB-RCS2-PA□□□□	(Cable)	112
CB-RCS2-PA□□□□	(Cable)	134
CB-RCS2-PLA□□□□	(Cable)	112 • 134
CB-REXT-CTL010	(Cable)	124
CB-REXT-SIO010	(Cable)	124
CB-SEL-SJ002	(Cable)	102 • 112
CB-SEL-USB010	(Cable)	102 • 112
CB-X2-PLA□□□□	(Cable)	112 • 134
CB-X3-PA□□□□	(Cable)	112 • 134
CB-X-LC□□□□	(Cable)	134
CB-X-PIO□□□□	(Cable)	134
CON-T	(Teaching pendant)	122

[D]

DP-3	(Dummy plug)	101 • 112
------	--------------	-----------

[I]

IA-101-XA-MW	(PC software)	133
IA-101-X-MW	(PC software)	111 • 133
IA-101-X-MW-J	(PC software)	101 • 111
IA-101-X-USB	(PC software)	101 • 111
IA-101-X-USBMW	(PC software)	133
IA-105-X-MW-A	(Expansion SIO board)	132
IA-105-X-MW-B	(Expansion SIO board)	132
IA-105-X-MW-C	(Expansion SIO board)	132
IA-XAB-BT	(Absolute-data backup battery)	132
IK2-PXBB1□□D	(IA kit)	31
IK2-PXBB1□□S	(IA kit)	29
IK2-PXBB2□□D	(IA kit)	35
IK2-PXBB2□□S	(IA kit)	33
IK2-PXBC1□□D	(IA kit)	23
IK2-PXBC1□□S	(IA kit)	21
IK2-PXBC2□□D	(IA kit)	27
IK2-PXBC2□□S	(IA kit)	25
IK2-PXBD1□□D	(IA kit)	15
IK2-PXBD1□□S	(IA kit)	13
IK2-PXBD2□□D	(IA kit)	19
IK2-PXBD2□□S	(IA kit)	17
IK2-PXZB1□□D	(IA kit)	39
IK2-PXZB1□□S	(IA kit)	37
IK2-PYBB1□□S	(IA kit)	41
IK2-SXBA1□□D	(IA kit)	69

IK2-SXBA1□□S	(IA kit)	67
IK2-SXBA2□□D	(IA kit)	73
IK2-SXBA2□□S	(IA kit)	71
IK2-SXBB1□□D	(IA kit)	61
IK2-SXBB1□□S	(IA kit)	59
IK2-SXBB2□□D	(IA kit)	65
IK2-SXBB2□□S	(IA kit)	63
IK2-SXBC1□□D	(IA kit)	53
IK2-SXBC1□□S	(IA kit)	51
IK2-SXBC2□□D	(IA kit)	57
IK2-SXBC2□□S	(IA kit)	55
IK2-SXBD1□□D	(IA kit)	45
IK2-SXBD1□□S	(IA kit)	43
IK2-SXBD2□□D	(IA kit)	49
IK2-SXBD2□□S	(IA kit)	47
IK2-SXZB1□□D	(IA kit)	77
IK2-SXZB1□□S	(IA kit)	75
IK2-SYBB1□□S	(IA kit)	79
IK3-PBBG1□□D	(IA kit)	83
IK3-PBBG1□□S	(IA kit)	81
IK3-SBBG1□□D	(IA kit)	88
IK3-SBBG1□□S	(IA kit)	85

[J]

JB-1	(ROBONET communication connection board)	123
------	--	-----

[P]

PP-1	(Power-supply connection plate)	123
PS-241	(24-V power supply)	123
PS-242	(24-V power supply)	123
PSEL-C	(Controller)	93
PU-1	(Panel unit)	101 • 111

[R]

RABU	(Simple absolute R unit)	121
RACON	(RACON unit)	120
RCM-101-MW	(PC software)	122
RCM-101-USB	(PC software)	122
RCM-E	(Teaching pendant)	122
RCM-P	(Teaching pendant)	122
REU-1	(Regenerative resistor unit)	132
REU-2	(Regenerative resistor unit)	111
REXT	(Expansion unit)	121
RGW-CC	(Gateway R unit)	118
RGW-DV	(Gateway R unit)	118
RGW-PR	(Gateway R unit)	119
RGW-SIO	(Gateway R unit)	119
ROBONET	(Controller)	113
RPCON	(RPCON unit)	120

[S]

SEL-T	(Teaching pendant)	133
SEL-TD	(Teaching pendant)	133
SEL-TD-J	(Teaching pendant)	10 • 11
SEL-T-J	(Teaching pendant)	10 • 11
SSEL-C	(Controller)	103

[T]

TN-1	(Terminal resistor board)	123
------	---------------------------	-----

[X]

XSEL-J	(Controller)	125
XSEL-K	(Controller)	125
XSEL-P	(Controller)	125
XSEL-Q	(Controller)	125

IAI America, Inc.

Headquarters: 2690 W. 237th Street Torrance, CA 90505 (800) 736-1712

Chicago Office: 1261 Hamilton Parkway Itasca, IL 60143 (800) 944-0333

Atlanta Office: 1220 Kennestone Circle, Suite 108, Marietta, GA 30066 (888) 354-9470

The information contained in this product brochure may change without prior notice due to product improvements.

IAI Industrieroboter GmbH

Ober der Roth 4, D-65824 Schwalbach am Taunus, Germany

www.intelligentactuator.com

