

ROBO Cylinder® Rod Type **RCS3**

All Models Equipped  
with a Battery-less Absolute Encoder as Standard  
High-payload Rod Type Also Now Available

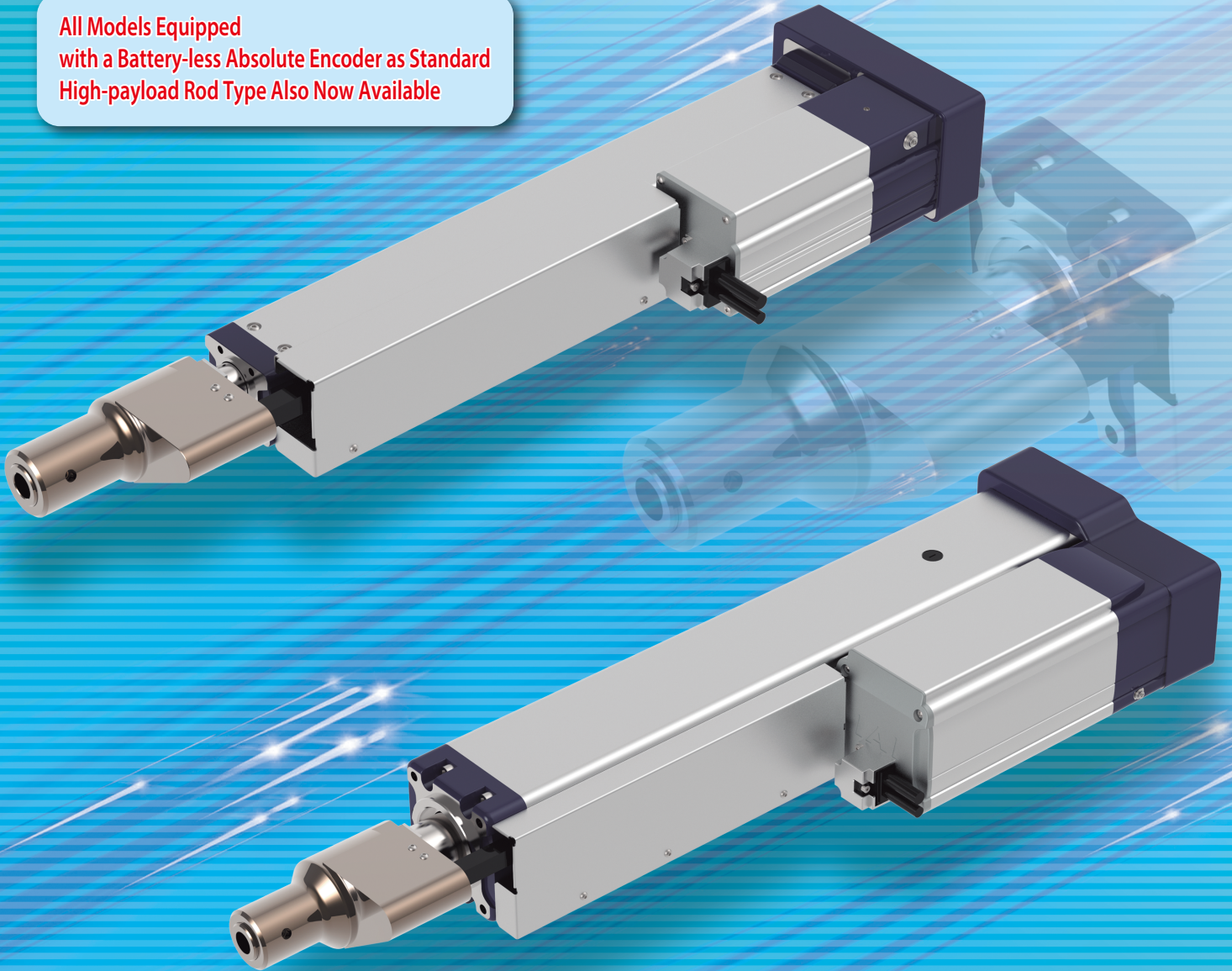

Rod type actuator that can be used in simple pressing. As it is capable of high precision position control, it can easily set the hard push force adjustment and position control that have been difficult with the hydraulic pressure.

## 1 Servo Press Specifications Also Available

The servo press specification actuator is equipped with a load cell to allow for the force control.

### What Is Push-motion Operation?

Similar to an air cylinder, push-motion operation is the function of keeping the rod and slider pushed to the work, etc. Servo press provides superior stop stability during pressing, which makes them optimal for push-motion operation. Also, servo press can be used in a wide variety of applications because it can be used in work operations that require strong push force, such as press fitting and caulking operation.

### What Is Force Control?

A function that can perform high precision push control output using the feedback data from the dedicated load cell installed in the actuator.

### What Is the Servo Press Specification?

The specification which can perform various push-motion operations by using the press program. For details, please refer to P. 3.

### <Application Examples>

#### Press-fitting a pin

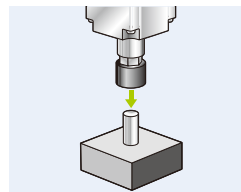

#### Riveting work

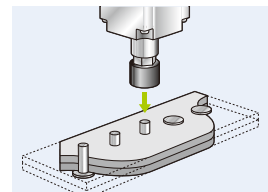

- Accurate push force can be managed
- Detailed push force setting can be set for each product

## 2 High Precision Load Control

Equipped with a dedicated load cell at the rod tip to detect the load applied to the pressed object. This provides the high precision load control with the loading repeatability of  $\pm 0.5\%$  F.S. (full-scale).





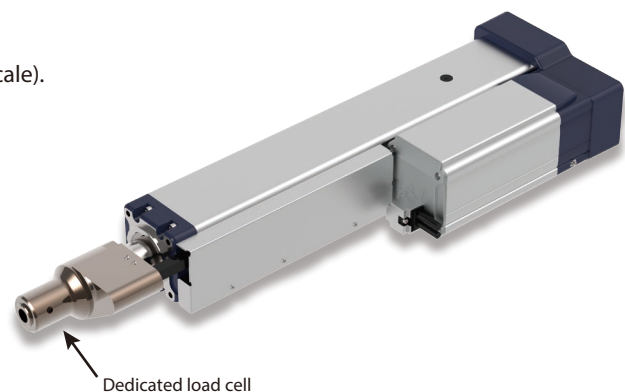

F.S.: Full Scale  
Maximum measurable value







# 3 Extensive Lineup

The servo press specification can be selected from 8 types with the max. push force of 200N~50,000N.

[Servo press specification]

	RCS3-RA4R	RCS3-RA6R	RCS3-RA7R	RCS3-RA8R
				
Stroke (mm)	110~410	115~415	120~520	100~500
Motor (W)	30	60	100	200
Lead (mm)	2.5	1.5	2	2.5
Max. push force (N)*	200	600	1200	2000
Max. payload (kg)	Horizontal	10	10	10
	Vertical	3	10	10
Max speed (mm/s)	125	75	100	125

	RCS3-RA10R	RCS2-RA13R		RCS3-RA15R	RCS3-RA20R
		1t Type	2t Type		
					
Stroke (mm)	100~500	50~200		100~500	100~500
Motor (W)	400	750		3300	3000
Lead (mm)	2.5	2.5	1.25	3.6	4
Max. push force (N)*	6000	9800	19600	30000	50000
Max. payload (kg)	Horizontal	15	15	15	15
	Vertical	15	15	220	220
Max speed (mm/s)	125	125	62	240	220

\* Max. push force can be achieved only during push mode with 1~10mm/s speed range.

# 4 Capable of Pushing at Maximum Push Force for Long Periods

RCS3-RA15R/RA20R types of servo press specification achieve the push time of 9s/10s at the maximum push force (30,000N/50,000N). They can be used for applications where the time until a predetermined push force is reached is indefinite such as compression molding of powders, applications where the push force is maintained from the pressurized state until cooling such as hot plate welding, and applications where the push force is maintained for a predetermined period such as the strain relief of workpiece.

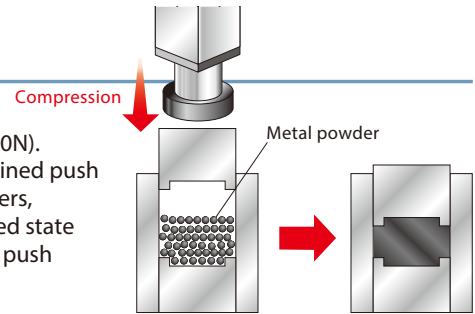

# 5 Equipped with a Battery-less Absolute Encoder as Standard

Equipped with a Battery-less Absolute Encoder as standard. There is no need to replace batteries, reducing the maintenance processes.

### Advantages of Battery-less Absolute

- The machine will no longer stop due to battery error (voltage drop, etc.).
- There is no need to purchase replacement batteries.
- There is no need to replace batteries, saving time and trouble such as absolute reset.





### Battery-less Absolute Encoder

No Battery,  
No Maintenance, No Homing,  
No Going Back to Incremental.

# 6 High-payload Rod Type is Also Available

Newly added High-payload Rod type (Position Type without load cell). It can be selected for transport application.

[Rod type]

	RCS2-RA13R		NEW RCS3-RA15R	NEW RCS3-RA20R
	1t Type	2t Type		
				
Stroke (mm)	50~200		100~500	100~500
Motor (W)	750		3300	3000
Lead (mm)	2.5	1.25	7.2	10
Max. push force (N)*	9800	19600	15000	20000
Max. payload (kg)	Horizontal	400	500	700
	Vertical	200	300	400
Max speed (mm/s)	125	62	400	400

\* Max. push force can be achieved only within 5~10mm/s speed range.

# Dedicated Software: Press Program

With this Press Program, one of two control methods, "Speed Control" or "Force Control", can be selected. In addition, one of four stop conditions, "Position", "Distance", "Load", or "Incremental Load", can be selected as the method for stopping. By utilizing a total of eight types of press methods, it is possible to handle a variety of press motion.

## Explanation of Operation

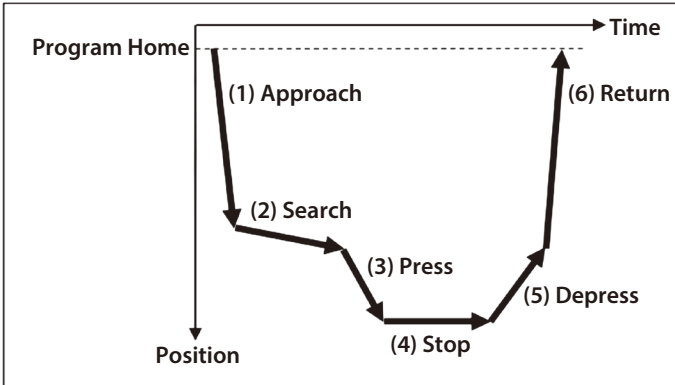

- (1) Approach (can be omitted)**  
Performs high-speed transfer until directly before contacting work
- (2) Search (can be omitted)**  
Detects work contact
- (3) Press (necessary)**  
Accelerates, then performs pressing work
- (4) Stop (can be omitted when set to 0)**  
Stops at a fixed position or continues to push
- (5) Depress (can be omitted)**  
Slowly separates from the work
- (6) Return (can be omitted)**  
Returns to the program home position at high speed

## Program Screen

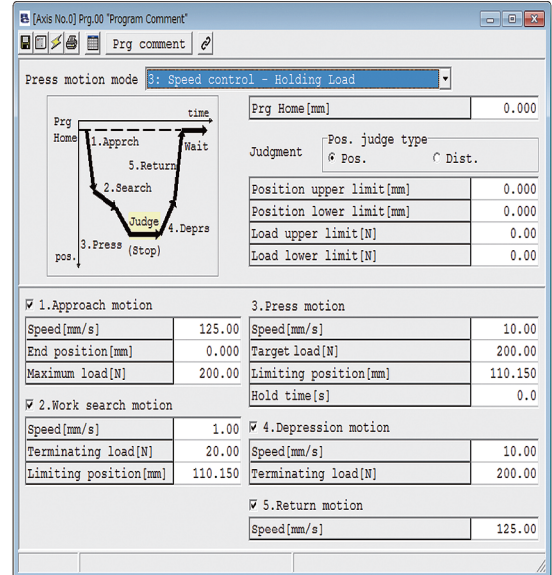

## Example of press fitting a machine part into a washer

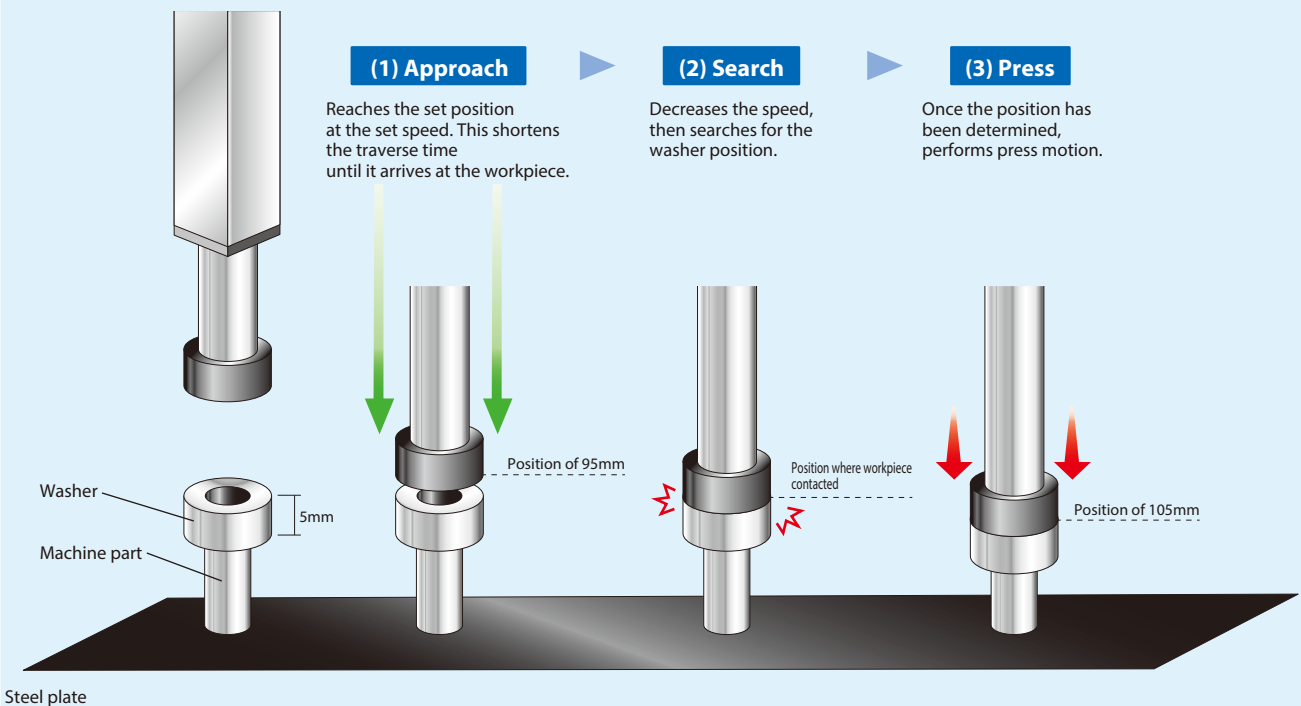

Mode		Internal control	Stop state	Applications
<b>Speed control</b> After arriving at the target position, stops while maintaining the <b>position</b> at the time of arrival.	Position stop	Positioning	Positioning stop	Press fitting, riveting, squeezing, etc. (primarily metalworking)
	Distance stop			
	Load stop			
	Incremental load stop			
<b>Force control</b> After arriving at the target position, it stops while maintaining the <b>force</b> at the time of arrival.	Position stop	Push	Continuing push-motion operation	Compressive molding, etc. of powders
	Distance stop			
	Load stop			
	Incremental load stop			

<b>Position stop</b> Performs pressing work to the specified position.	<b>Load stop</b> Performs pressing work that stops at the position at which the specified load was detected.
<b>Distance stop</b> Performs pressing work by moving a specified distance and then stopping. This is optimal in situations in which the press start position changes.	<b>Incremental load stop</b> Performs pressing work that stops at the position at which the load (sum of the press start load and the specified incremental load) has been detected. * It is possible to perform the operation by linking two programs together. For details, please refer to the instruction manual.

### Explanation of Operation

From the end of press to the end of the stop state, it is possible to perform position judgment and load judgment.

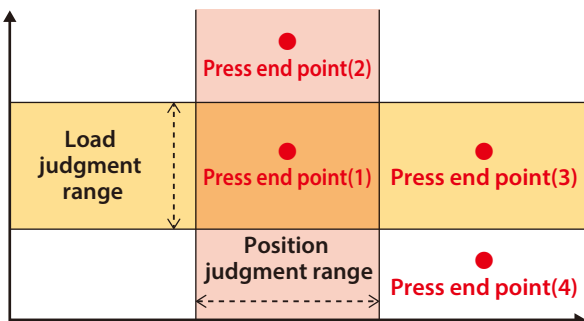

<Judgment Results>

No.	Position	Load
①	OK	OK
②	OK	NG
③	NG	OK
④	NG	NG

- When a result of NG has been detected for either the position or load, the program ends abnormally
- It is also possible to set position only, load only, or neither

# RCS3-RA4R (Servo press specification)

Battery-less Absolute
Motor Unit Type
Side-mounted Motor
Body Width 40\* mm
200v AC Servo Motor

Model Specification Items	<b>RCS3</b>	<b>RA4R</b>	<b>WA</b>	<b>30</b>	<b>2.5</b>	<input type="checkbox"/>	<b>T2</b>	<input type="checkbox"/>	<input type="checkbox"/>
	Series	Type	Encoder Type	Motor Type	Lead	Stroke	Applicable Controllers	Cable Length	Options
			WA: Battery-less Absolute	30: Servo motor 30W	2.5: Lead 2.5mm	110: 110mm ? 410: 410mm (Every 50mm)	T2: SCON-CB/CGB (For servo press only)	N : None P : 1m S : 3m M : 5m X□□ : Specified length R□□ : Robot cable	Refer to Options table below. * For side-mounted motor type, specify the mount direction (ML/MR).

\* Does not include a controller.  
 \* Please contact IAI for more information about the model specification items.  
 \* Body width does not include the width of the side-mounted motor.



\* CE is an available option.



\* Depending on the model, there may be some limitations to using the vertical mount position. Please contact IAI for more information.

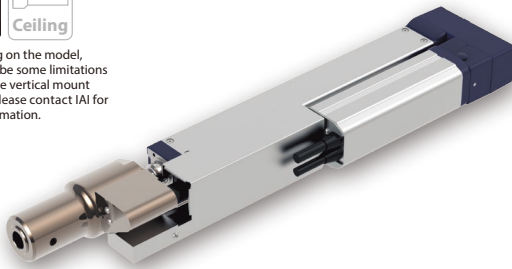

## Correlation Diagram of Push Force and Current Limit Value

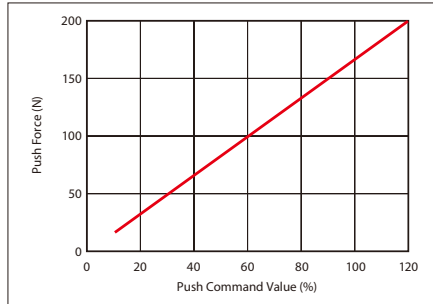

### Caution:

- The correlation between push force and push command value are strictly for reference purposes. Actual numbers may vary slightly.
- The push command value should be 12% or more because the push force will be unstable when the push command value is low.

**POINT Selection Notes**

- (1) There are no limitations on the continuous push time. The duty ratio is also 100% and continuous operation is possible.
- (2) Customer's tooling is to be mounted on the load cell itself. In case any radial or moment load is applied to the load cell, please consider adding the external guides, etc. to offset those side loads.
- (3) Please install a support block when front mounting or back mounting a horizontally mounted actuator that is 150st or more. (Refer to page 34 "Notes When Installing")
- (4) Servo Press with load cell should not be used for pulling motion. It will damage the load cell.

## Actuator Specifications

### Lead and Payload

Model Number	Motor wattage (W)	Lead (mm)	Max. speed (mm/s)	Max. acceleration (G)	Max. payload Horizontal (kg)	Max. payload Vertical (kg)	Rated thrust (N)	Max. push force (N)
RCS3-RA4R-WA-30-2.5-①-T2-②-③	30	2.5	125	0.5	3	3	126	200

Legend: ① Stroke ② Cable Length ③ Option \* Max. horizontal payload means max. weight on the customer's external guide. \*\* Max. push force can be achieved only within 1~10mm/s speed range.

### Stroke and Max Speed

Lead (mm)	Stroke (mm)	110~410
2.5		125

(Unit: mm/s)

### ① Stroke

① Stroke (mm)	RCS3-RA4R
110	<input type="radio"/>
160	<input type="radio"/>
210	<input type="radio"/>
260	<input type="radio"/>
310	<input type="radio"/>
360	<input type="radio"/>
410	<input type="radio"/>

### ② Cable Length

Type	Cable Code
Standard	P(1m)
	S(3m)
	M(5m)
Specified length (Standard cable)	X06(6m) ~X10(10m)
	X11(11m)~X15(15m)
	X16(16m)~X20(20m)
Robot cable	R01(1m) ~R03(3m)
	R04(4m) ~R05(5m)
	R06(6m) ~R10(10m)
	R11(11m)~R15(15m)
	R16(16m)~R20(20m)

\* Please contact IAI for maintenance cables.

### ③ Options

Name	Option Code	Reference Page
Brake	B	See P.35
CE compliant	CE	See P.35
Cable exit direction (Outside)	CJO	See P.35
Flange (Front)	FL	See P.35
Foot bracket (*1)	FT	See P.36
Equipped with load cell (Standard equipment) (*2)	LCT	See P.37
Motor side-mounted (left)	ML	See P.37
Motor side-mounted (right)	MR	See P.37

(\*1) Refer to P. 37 for the number of brackets included.

(\*2) Please make sure to enter "LCT" in the box of Model Specification Items to select the actuator with load cell option.

## Actuator Specifications

Item	Description
Drive system	Ball screw φ8mm rolled C10
Positioning repeatability	±0.01mm
Lost motion	0.1mm or less
Load cell rated capacity	200N
Loading repeatability (*3)	±0.5% F.S (*4)
Ambient operating temp. & humidity	0°C~40°C, 85% RH or less (non-condensing)

(\*3) Ratio (in percentage) of the load variations caused by the repeated operations to the load cell rated capacity

(\*4) F.S.: Full Scale, the maximum measurable value.

Dimensions

CAD drawings can be downloaded from our website.  
www.intelligentactuator.com



\*1 Connect the motor-encoder cables. Please contact IAI for more details on the cable.  
\*2 While the rod is returning to its home position, please be careful of interference from surrounding objects, as it will travel until it reaches the mechanical end.  
M.E: Mechanical end  
S.E: Stroke end

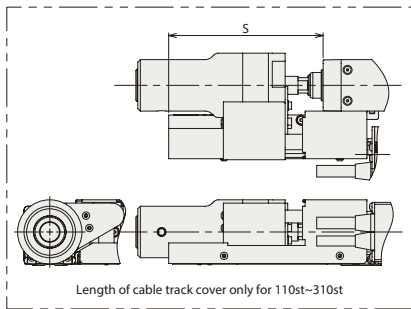
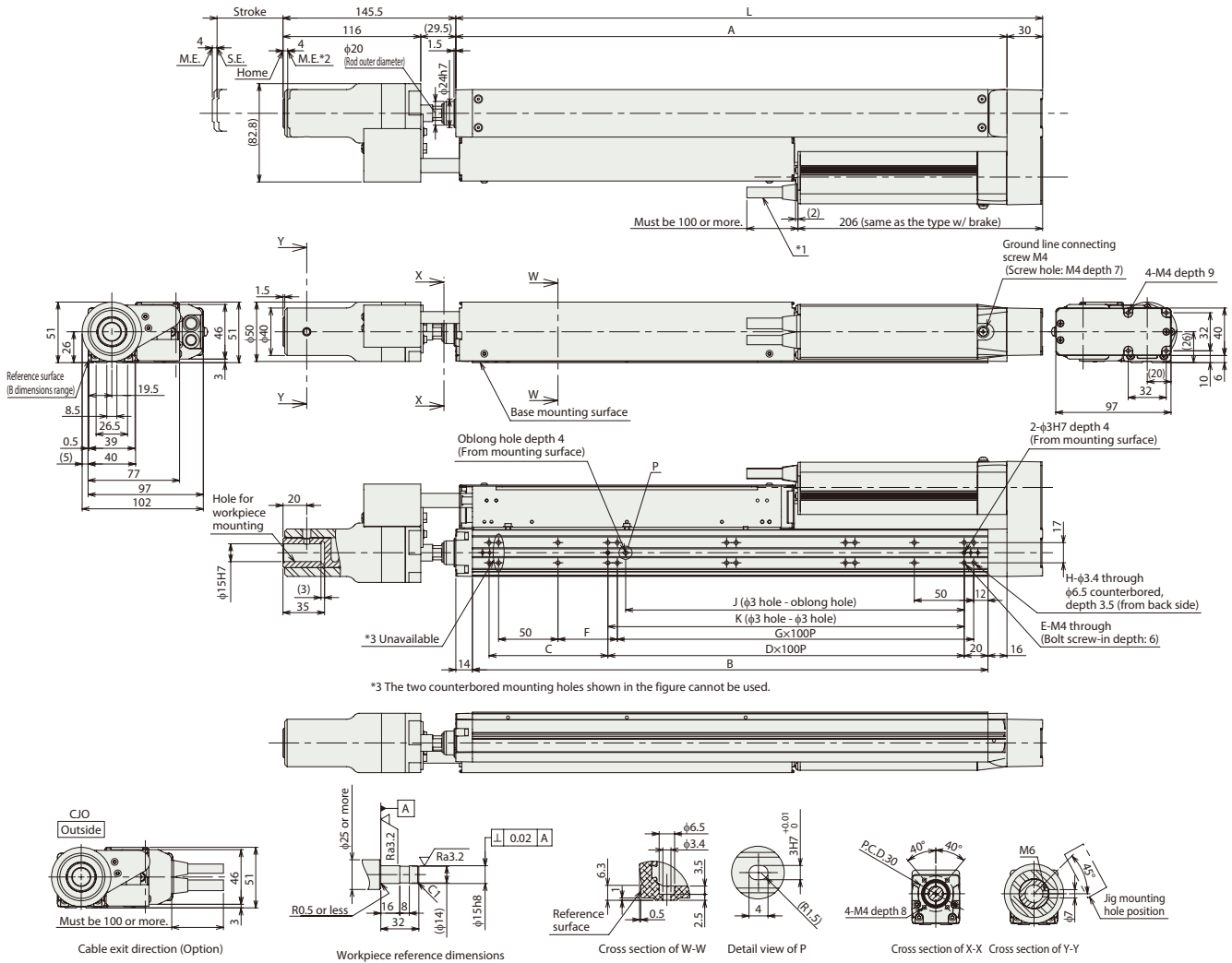

Dimensions and Mass by Stroke

Stroke	110	160	210	260	310	360	410
L	244	294	344	394	444	494	544
A	214	264	314	364	414	464	514
B	184	234	284	334	384	434	484
C	50	100	50	100	50	100	50
D	1	1	2	2	3	3	4
E	6	6	8	8	10	10	12
F	100	50	100	50	100	50	100
G	0	1	1	2	2	3	3
H	8	10	10	12	12	14	14
J	85	85	185	185	285	285	385
K	100	100	200	200	300	300	400
S	120	100	75	50	25	-	-
Mass (kg)	Without brake	3.1	3.2	3.4	3.6	3.8	4.1
	With brake	3.4	3.5	3.7	3.9	4.1	4.4

Applicable Controllers

The RCS3 series actuators can be operated by the controllers indicated below. Please select the type depending on your intended use.

Name	External view	Max. number of connectable axes	Power supply voltage	Control method				Network * Option	Maximum number of positioning points	Reference page
				Positioner	Pulse train	Program	Press program			
SCON-CB/CGB (For servo press only)		1	Single-phase 100VAC /200VAC	-	-	-	●	DeviceNet CC-Link EtherCAT EtherNet/IP CompoNet MIECHATROLINK EtherCAT EtherNet/IP CompoNet	-	Please contact IAI for more information.

# RCS3-RA6R (Servo press specification)

Battery-less Absolute
Motor Unit Type
Side-mounted Motor
Body Width 60\* mm
200v AC Servo Motor

Model Specification Items	<b>RCS3</b>	<b>RA6R</b>	<b>WA</b>	<b>60</b>	<b>1.5</b>	<input type="checkbox"/>	<b>T2</b>	<input type="checkbox"/>	<input type="checkbox"/>
	Series	Type	Encoder Type	Motor Type	Lead	Stroke	Applicable Controllers	Cable Length	Options
			WA: Battery-less Absolute	60: Servo motor 60W	1.5: Lead 1.5mm	115: 115mm ? 415: 415mm (Every 50mm)	T2: SCON-CB/ CGB (For servo press only)	N : None P : 1m S : 3m M : 5m X□□ : Specified length R□□ : Robot cable	Refer to Options table below. * Specify cable exit direction (CJT/CJB/CJO). For side-mounted motor type, specify the mount direction (ML/MR).

\* Does not include a controller.  
 \* Please contact IAI for more information about the model specification items.  
 \* Body width does not include the width of the side-mounted motor.

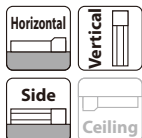

\* Depending on the model, there may be some limitations to using the vertical mount position. Please contact IAI for more information.

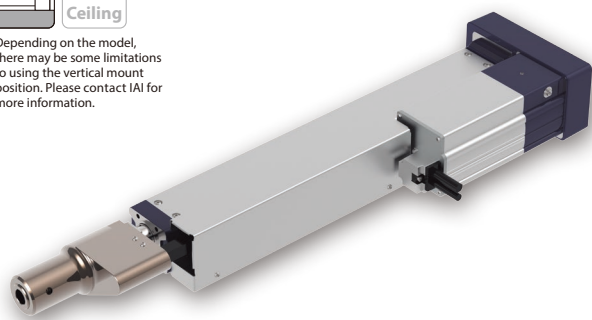

## Correlation Diagram of Push Force and Current Limit Value

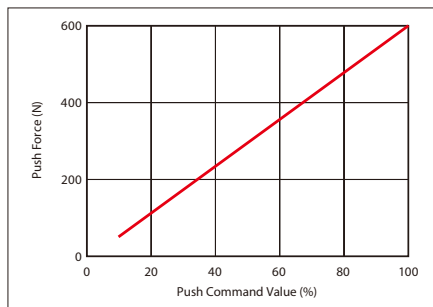

**Caution:**  
 ● The correlation between push force and push command value are strictly for reference purposes. Actual numbers may vary slightly.  
 ● The push command value should be 10% or more because the push force will be unstable when the push command value is low.

**POINT Selection Notes**

- For push-motion operation, check the allowable time period of continuous push-motion set with a different thrust force. Also, please check that the allowable continuous operational thrust force for the actual push cycle is less than the allowable continuous operational thrust force. (Even if there is no push motion) Please refer to P.27 for more information.
- Customer's tooling is to be mounted on the load cell itself. In case any radial or moment load is applied to the load cell, please consider adding the external guides, etc. to offset those side loads.
- Please install a support block when front mounting or back mounting a horizontally mounted actuator that is 150st or more. (Refer to page 34 "Notes When Installing")
- Servo Press with load cell should not be used for pulling motion. It will damage the load cell.

## Actuator Specifications

### Lead and Payload

Model Number	Motor wattage (W)	Lead (mm)	Max. speed (mm/s)	Max. acceleration (G)	Max. payload		Rated thrust (N)	Max. push force (N)
					Horizontal (kg)	Vertical (kg)		
RCS3-RA6R-WA-60-1.5-①-T2-②-③	60	1.5	75	0.3	10	10	566	600

Legend: ① Stroke ② Cable Length ③ Option \* Max. horizontal payload means max. weight on the customer's external guide.  
 \*\* Max. push force can be achieved only within 1~10mm/s speed range.

### Stroke and Max Speed

Lead (mm)	Stroke (mm)	115~415
1.5		75

(Unit: mm/s)

### ① Stroke

① Stroke (mm)	RCS3-RA6R
115	<input type="radio"/>
165	<input type="radio"/>
215	<input type="radio"/>
265	<input type="radio"/>
315	<input type="radio"/>
365	<input type="radio"/>
415	<input type="radio"/>

### ② Cable Length

Type	Cable Code
Standard	P(1m)
	S(3m)
	M(5m)
Specified length (Standard cable)	X06(6m) ~X10(10m)
	X11(11m)~X15(15m)
	X16(16m)~X20(20m)
Robot cable	R01(1m) ~R03(3m)
	R04(4m) ~R05(5m)
	R06(6m) ~R10(10m)
	R11(11m)~R15(15m)
	R16(16m)~R20(20m)

\* Please contact IAI for maintenance cables.

### ③ Options

Name	Option Code	Reference Page
Brake	B	See P.35
Cable exit direction (Top)	CJT	See P.35
Cable exit direction (Bottom) (*2)	CJB	See P.35
Cable exit direction (Outside)	CJO	See P.35
Flange (Front)	FL	See P.35
Foot bracket (*1)	FT	See P.36
Equipped with load cell (Standard equipment) (*3)	LCT	See P.37
Motor side-mounted (left)	ML	See P.37
Motor side-mounted (right)	MR	See P.37

(\*1) Refer to P. 37 for the number of brackets included.  
 (\*2) The foot bracket cannot be chosen when you select the actuator whose stroke is 365mm or less.  
 (\*3) Please make sure to enter "LCT" in the box of Model Specification Items to select the actuator with load cell option.

## Actuator Specifications

Item	Description
Drive system	Ball screw φ10mm rolled C10
Positioning repeatability	±0.01mm
Lost motion	0.1mm or less
Load cell rated capacity	600N
Loading repeatability (*4)	±0.5% F.S (*5)
Ambient operating temp. & humidity	0°C~40°C, 85% RH or less (non-condensing)

(\*4) Ratio (in percentage) of the load variations caused by the repeated operations to the load cell rated capacity

(\*5) F.S.: Full Scale, the maximum measurable value.



Dimensions

CAD drawings can be downloaded from our website.  
www.intelligentactuator.com



\*1 Connect the motor-encoder cables. Please contact IAI for more details on the cable.  
\*2 While the rod is returning to its home position, please be careful of interference from surrounding objects, as it will travel until it reaches the mechanical end.  
M.E: Mechanical end  
S.E: Stroke end

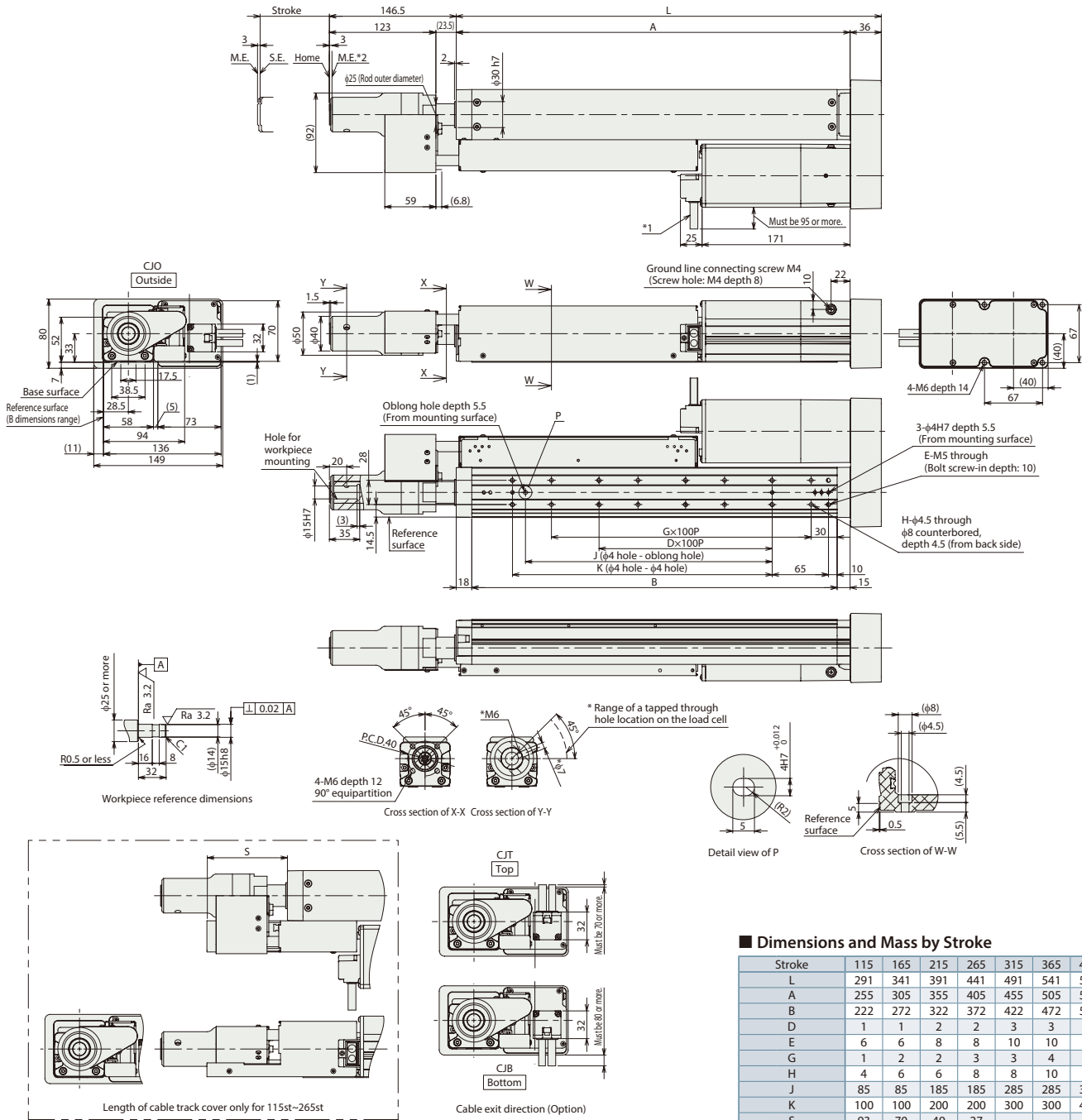

■ Dimensions and Mass by Stroke

Stroke	115	165	215	265	315	365	415	
L	291	341	391	441	491	541	591	
A	255	305	355	405	455	505	555	
B	222	272	322	372	422	472	522	
D	1	1	2	2	3	3	4	
E	6	6	8	8	10	10	12	
G	1	2	2	3	3	4	4	
H	4	6	6	8	8	10	10	
J	85	85	185	185	285	285	385	
K	100	100	200	200	300	300	400	
S	93	70	49	27	-	-	-	
Mass (kg)	Without brake	4.7	4.9	5.2	5.5	5.8	6.1	6.4
	With brake	4.9	5.1	5.4	5.7	6.0	6.3	6.6

Applicable Controllers

The RCS3 series actuators can be operated by the controllers indicated below. Please select the type depending on your intended use.

Name	External view	Max. number of connectable axes	Power supply voltage	Control method				Network * Option	Maximum number of positioning points	Reference page
				Positioner	Pulse train	Program	Press program			
SCON-CB/CGB (For servo press only)		1	Single-phase 100VAC /200VAC	-	-	-	●		-	Please contact IAI for more information.

# RCS3-RA7R (Servo press specification)

Battery-less Absolute

Motor Unit Type

Side-mounted Motor

Body Width 70\* mm

200v AC Servo Motor

<b>Model Specification Items</b>	<b>RCS3</b>	<b>RA7R</b>	<b>WA</b>	<b>100</b>	<b>2</b>		<b>T2</b>		
	Series	Type	Encoder Type	Motor Type	Lead	Stroke	Applicable Controllers	Cable Length	Options
			WA: Battery-less Absolute	100: Servo motor 100W	2: Lead 2mm	120: 120mm 520: 520mm (Every 50mm)	T2: SCON-CB/ CGB (For servo press only)	N : None P : 1m S : 3m M : 5m X□□ : Specified length R□□ : Robot cable	Refer to Options table below. * Specify cable exit direction (CJT/CJB/CJO). For side-mounted motor type, specify the mount direction (ML/MR).

\* Does not include a controller.  
\* Please contact IAI for more information about the model specification items.  
\* Body width does not include the width of the side-mounted motor.

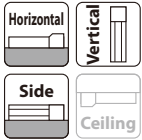

\* Depending on the model, there may be some limitations to using the vertical mount position. Please contact IAI for more information.

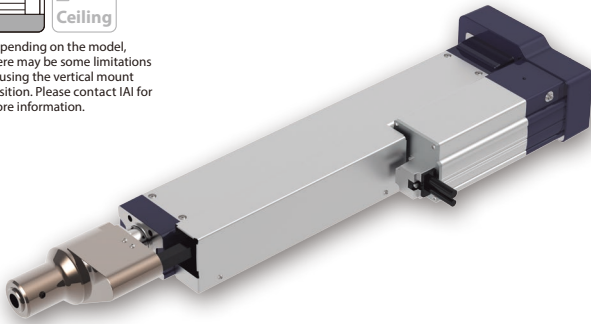

## Correlation Diagram of Push Force and Current Limit Value

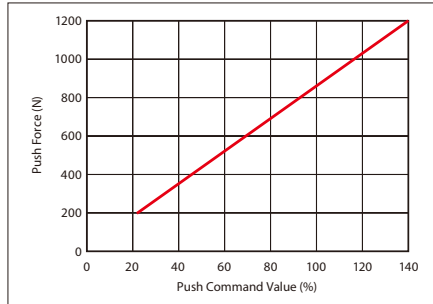

### Caution:

- The correlation between push force and push command value are strictly for reference purposes. Actual numbers may vary slightly.
- The push command value should be 24% or more because the push force will be unstable when the push command value is low.

POINT  
Selection  
Notes

(1) For push-motion operation, check the allowable time period of continuous push-motion set with a different thrust force. Also, please check that the allowable continuous operational thrust force for the actual push cycle is less than the allowable continuous operational thrust force. (Even if there is no push motion) Please refer to P.27 for more information.

(2) Customer's tooling is to be mounted on the load cell itself. In case any radial or moment load is applied to the load cell, please consider adding the external guides, etc. to offset those side loads.

(3) Please install a support block when front mounting or back mounting a horizontally mounted actuator that is 150st or more. (Refer to page 34 "Notes When Installing")

(4) Servo Press with load cell should not be used for pulling motion. It will damage the load cell.

## Actuator Specifications

### Lead and Payload

Model Number	Motor wattage (W)	Lead (mm)	Max. speed (mm/s)	Max. acceleration (G)	Max. payload Horizontal (kg)	Max. payload Vertical (kg)	Rated thrust (N)	Max. push force (N)
RCS3-RA7R-WA-100-2-①-T2-②-③	100	2	100	0.3	10	10	849	1200

Legend: ① Stroke ② Cable Length ③ Option \* Max. horizontal payload means max. weight on the customer's external guide. \*\* Max. push force can be achieved only within 1~10mm/s speed range.

### Stroke and Max Speed

Lead (mm)	Stroke (mm)	120~520
2		100

(Unit: mm/s)

### ① Stroke

① Stroke (mm)	RCS3-RA7R
120	○
170	○
220	○
270	○
320	○
370	○
420	○
470	○
520	○

### ② Cable Length

Type	Cable Code
Standard	<b>P</b> (1m)
	<b>S</b> (3m)
	<b>M</b> (5m)
Specified length (Standard cable)	<b>X06</b> (6m) ~ <b>X10</b> (10m)
	<b>X11</b> (11m)~ <b>X15</b> (15m)
	<b>X16</b> (16m)~ <b>X20</b> (20m)
Robot cable	<b>R01</b> (1m) ~ <b>R03</b> (3m)
	<b>R04</b> (4m) ~ <b>R05</b> (5m)
	<b>R06</b> (6m) ~ <b>R10</b> (10m)
	<b>R11</b> (11m)~ <b>R15</b> (15m)
	<b>R16</b> (16m)~ <b>R20</b> (20m)

\* Please contact IAI for maintenance cables.

### ③ Options

Name	Option Code	Reference Page
Brake	<b>B</b>	See P.35
Cable exit direction (Top)	<b>CJT</b>	See P.35
Cable exit direction (Bottom)	<b>CJB</b>	See P.35
Cable exit direction (Outside)	<b>CJO</b>	See P.35
Flange (Front)	<b>FL</b>	See P.35
Foot bracket (*1)	<b>FT</b>	See P.36
Equipped with load cell (Standard equipment) (*2)	<b>LCT</b>	See P.37
Motor side-mounted (left)	<b>ML</b>	See P.37
Motor side-mounted (right)	<b>MR</b>	See P.37

(\*1) Refer to P. 37 for the number of brackets included.

(\*2) Please make sure to enter "LCT" in the box of Model Specification Items to select the actuator with load cell option.

## Actuator Specifications

Item	Description
Drive system	Ball screw φ12mm rolled C10
Positioning repeatability	±0.01mm
Lost motion	0.1mm or less
Load cell rated capacity	2000N
Loading repeatability (*3)	±0.5% F.S (*4)
Ambient operating temp. & humidity	0°C~40°C, 85% RH or less (non-condensing)

(\*3) Ratio (in percentage) of the load variations caused by the repeated operations to the load cell rated capacity

(\*4) F.S.: Full Scale, the maximum measurable value.

Dimensions

CAD drawings can be downloaded from our website.  
www.intelligentactuator.com



\*1 Connect the motor-encoder cables. Please contact IAI for more details on the cable.  
\*2 While the rod is returning to its home position, please be careful of interference from surrounding objects, as it will travel until it reaches the mechanical end.  
M.E: Mechanical end  
S.E: Stroke end

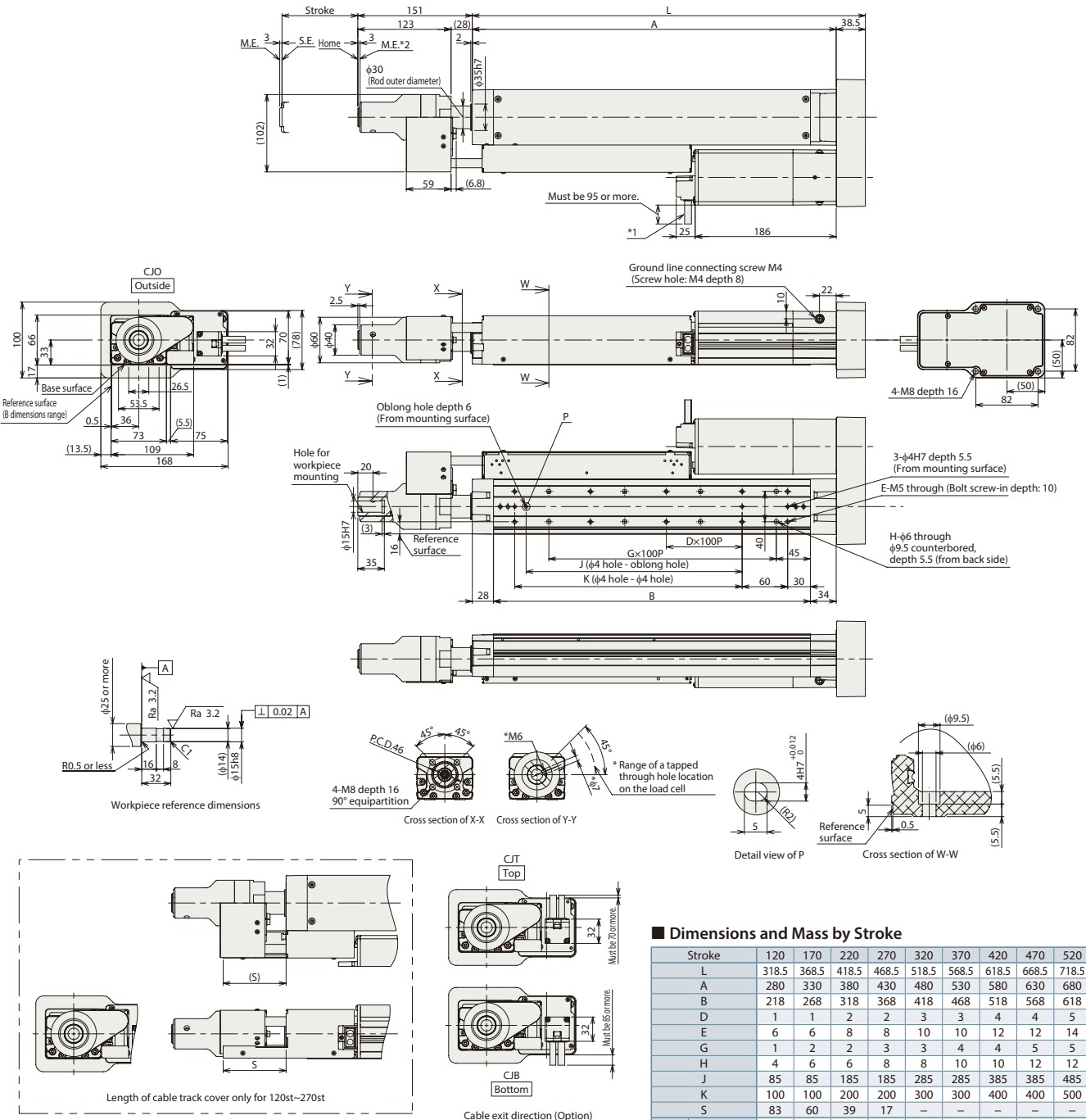

Applicable Controllers

The RCS3 series actuators can be operated by the controllers indicated below. Please select the type depending on your intended use.

Name	External view	Max. number of connectable axes	Power supply voltage	Control method				Network * Option	Maximum number of positioning points	Reference page
				Positioner	Pulse train	Program	Press program			
SCON-CB/CGB (For servo press only)		1	Single-phase 100VAC /200VAC	-	-	-	●	DeviceNet CC-Link EtherCAT EtherNet/IP CompoNet MECHATROLINK EtherCAT EtherNet/IP CANOPEN	-	Please contact IAI for more information.

# RCS3-RA8R (Servo press specification)

Battery-less Absolute
Motor Unit Type
Side-mounted Motor
Body Width 90\* mm
200v AC Servo Motor

Model Specification Items	<b>RCS3</b>	<b>RA8R</b>	<b>WA</b>	<b>200</b>	<b>2.5</b>	<input type="checkbox"/>	<b>T2</b>	<input type="checkbox"/>	<input type="checkbox"/>
	Series	Type	Encoder Type	Motor Type	Lead	Stroke	Applicable Controllers	Cable Length	Options
			WA: Battery-less Absolute	200: Servo motor 200W	2.5: Lead 2.5mm	100: 100mm ? 500: 500mm (Every 50mm)	T2: SCON-CB/ CGB (For servo press only)	N : None P : 1m S : 3m M : 5m X□□ : Specified length R□□ : Robot cable	Refer to Options table below. * Specify cable exit direction (CJT/CJB/CJO). For side-mounted motor type, specify the mount direction (ML/MR).

\* Does not include a controller.  
 \* Please contact IAI for more information about the model specification items.  
 \* Body width does not include the width of the side-mounted motor.

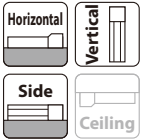

\* Depending on the model, there may be some limitations to using the vertical mount position. Please contact IAI for more information.

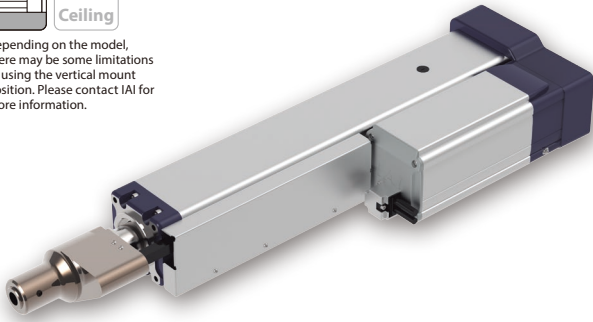

## Correlation Diagram of Push Force and Current Limit Value

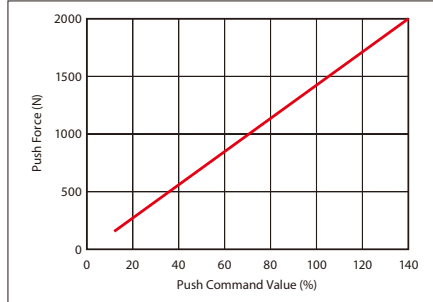

- Caution:**
- The correlation between push force and push command value are strictly for reference purposes. Actual numbers may vary slightly.
  - The push command value should be 14% or more because the push force will be unstable when the push command value is low.

**POINT Selection Notes**

- (1) For push-motion operation, check the allowable time period of continuous push-motion set with a different thrust force. Also, please check that the allowable continuous operational thrust force for the actual push cycle is less than the allowable continuous operational thrust force. (Even if there is no push motion) Please refer to P.27 for more information.
- (2) Customer's tooling is to be mounted on the load cell itself. In case any radial or moment load is applied to the load cell, please consider adding the external guides, etc. to offset those side loads.
- (3) Please install a support block when front mounting or back mounting a horizontally mounted actuator that is 150st or more. (Refer to page 34 "Notes When Installing")
- (4) Servo Press with load cell should not be used for pulling motion. It will damage the load cell.

## Actuator Specifications

### Lead and Payload

Model Number	Motor wattage (W)	Lead (mm)	Max. speed (mm/s)	Max. acceleration (G)	Max. payload		Rated thrust (N)	Max. push force (N)
					Horizontal (kg)	Vertical (kg)		
RCS3-RA8R-WA-200-2.5-①-T2-②-③	200	2.5	125	0.2	10	10	1367	2000

Legend: ① Stroke ② Cable Length ③ Option \* Max. horizontal payload means max. weight on the customer's external guide. \*\* Max. push force can be achieved only within 1~10mm/s speed range.

### Stroke and Max Speed

Lead (mm)	Stroke (mm)	100~500

(Unit: mm/s)

### ① Stroke

① Stroke (mm)	RCS3-RA8R
100	○
150	○
200	○
250	○
300	○
350	○
400	○
450	○
500	○

### ② Cable Length

Type	Cable Code
Standard	P(1m)
	S(3m)
	M(5m)
Specified length (Standard cable)	X06(6m) ~X10(10m)
	X11(11m)~X15(15m)
	X16(16m)~X20(20m)
Robot cable	R01(1m) ~R03(3m)
	R04(4m) ~R05(5m)
	R06(6m) ~R10(10m)
	R11(11m)~R15(15m)
	R16(16m)~R20(20m)

\* Please contact IAI for maintenance cables.

### ③ Options

Name	Option Code	Reference Page
Brake	B	See P.35
Cable exit direction (Top)	CJT	See P.35
Cable exit direction (Bottom) (*2)	CJB	See P.35
Cable exit direction (Outside)	CJO	See P.35
Flange (Front)	FL	See P.35
Foot bracket (*1)	FT	See P.36
Equipped with load cell (Standard equipment) (*3)	LCT	See P.37
Motor side-mounted (left)	ML	See P.37
Motor side-mounted (right)	MR	See P.37

(\*1) Refer to P. 37 for the number of brackets included.  
 (\*2) The foot bracket cannot be chosen when you select the actuator whose stroke is 100mm.  
 (\*3) Please make sure to enter "LCT" in the box of Model Specification Items to select the actuator with load cell option.

## Actuator Specifications

Item	Description
Drive system	Ball screw φ16mm rolled C10
Positioning repeatability	±0.01mm
Lost motion	0.1mm or less
Load cell rated capacity	2000N
Loading repeatability (*4)	±0.5% F.S (*5)
Ambient operating temp. & humidity	0°C~40°C, 85% RH or less (non-condensing)

(\*4) Ratio (in percentage) of the load variations caused by the repeated operations to the load cell rated capacity

(\*5) F.S.: Full Scale, the maximum measurable value.

Dimensions

CAD drawings can be downloaded from our website.  
www.intelligentactuator.com



\*1 Connect the motor-encoder cables. Please contact IAI for more details on the cable.  
\*2 While the rod is returning to its home position, please be careful of interference from surrounding objects, as it will travel until it reaches the mechanical end.  
M.E: Mechanical end  
S.E: Stroke end

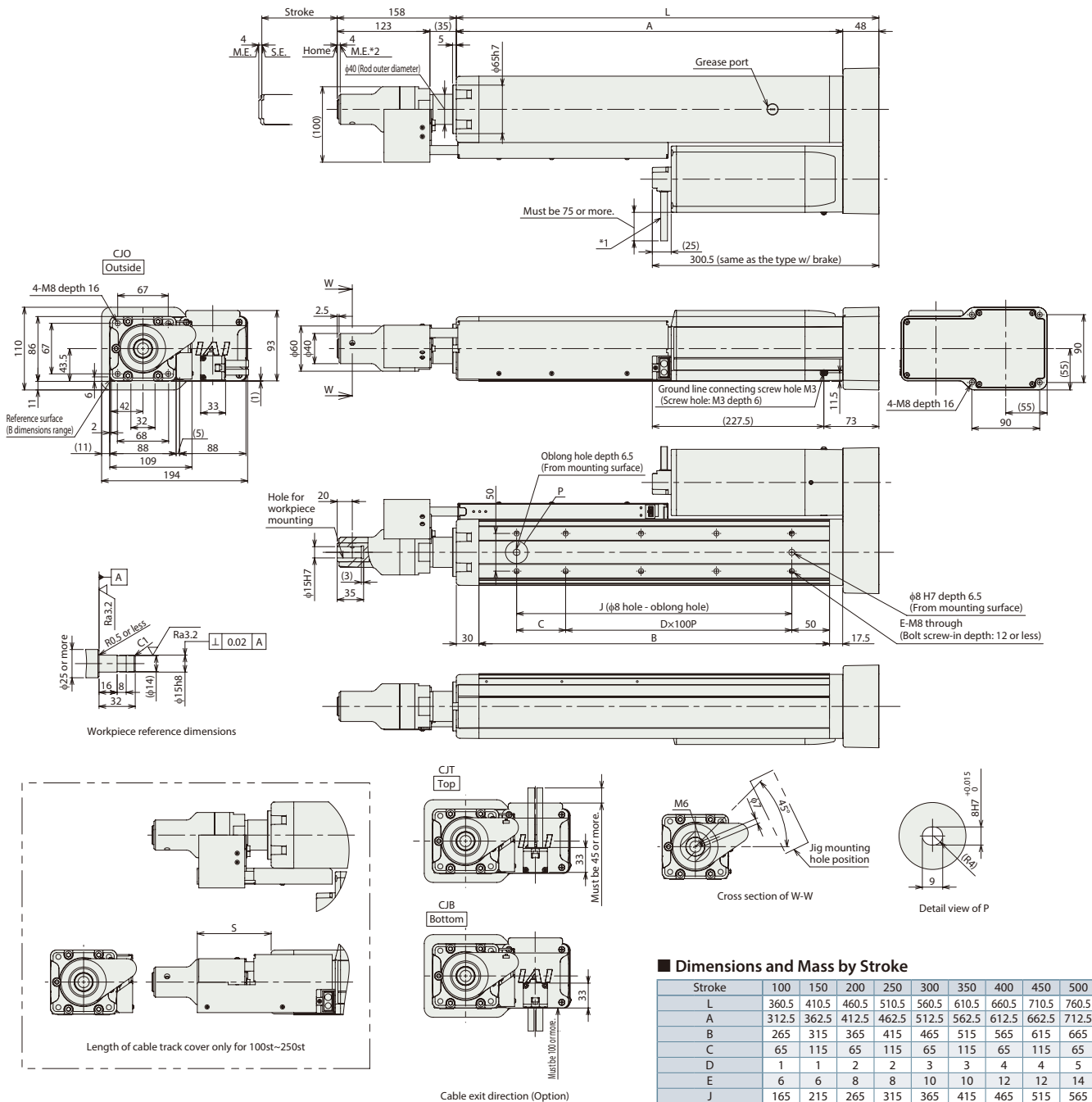

■ Dimensions and Mass by Stroke

Stroke	100	150	200	250	300	350	400	450	500
L	360.5	410.5	460.5	510.5	560.5	610.5	660.5	710.5	760.5
A	312.5	362.5	412.5	462.5	512.5	562.5	612.5	662.5	712.5
B	265	315	365	415	465	515	565	615	665
C	65	115	65	115	65	115	65	115	65
D	1	1	2	2	3	3	4	4	5
E	6	6	8	8	10	10	12	12	14
J	165	215	265	315	365	415	465	515	565
S	98	63	42	21	-	-	-	-	-
Mass (kg)									
Without brake	10.2	10.8	11.3	11.9	12.5	13	13.6	14.1	14.7
With brake	10.7	11.3	11.8	12.4	13.0	13.5	14.1	14.6	15.2

Applicable Controllers

The RCS3 series actuators can be operated by the controllers indicated below. Please select the type depending on your intended use.

Name	External view	Max. number of connectable axes	Power supply voltage	Control method				Network * Option	Maximum number of positioning points	Reference page
				Positioner	Pulse train	Program	Press program			
SCON-CB/CGB (For servo press only)		1	Single-phase 100VAC /200VAC	-	-	-	●		-	Please contact IAI for more information.

# RCS3-RA10R (Servo press specification)

Battery-less Absolute
Motor Unit Type
Side-mounted Motor
Body Width 110\* mm
200v AC Servo Motor

Model Specification Items	<b>RCS3</b>	<b>RA10R</b>	<b>WA</b>	<b>400</b>	<b>2.5</b>	<input type="checkbox"/>	<b>T2</b>	<input type="checkbox"/>	<input type="checkbox"/>
	Series	Type	Encoder Type	Motor Type	Lead	Stroke	Applicable Controllers	Cable Length	Options
			WA: Battery-less Absolute	400: Servo motor 400W	2.5: Lead 2.5mm	100: 100mm ? 500: 500mm (Every 50mm)	T2: SCON-CB/ CGB (For servo press only)	N : None P : 1m S : 3m M : 5m X□□ : Specified length R□□ : Robot cable	Refer to Options table below. * Specify cable exit direction (CJT/CJB/CJO). For side-mounted motor type, specify the mount direction (ML/MR).

\* Does not include a controller.  
 \* Please contact IAI for more information about the model specification items.  
 \* Body width does not include the width of the side-mounted motor.

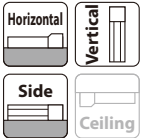

\* Depending on the model, there may be some limitations to using the vertical mount position. Please contact IAI for more information.

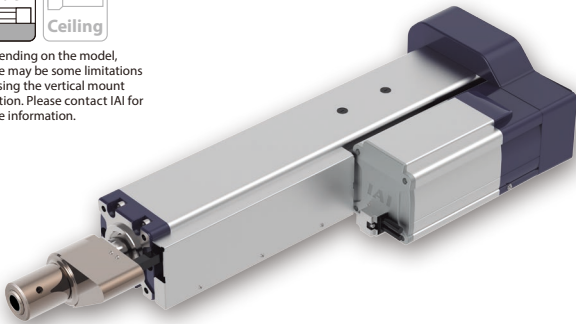

## Correlation Diagram of Push Force and Current Limit Value

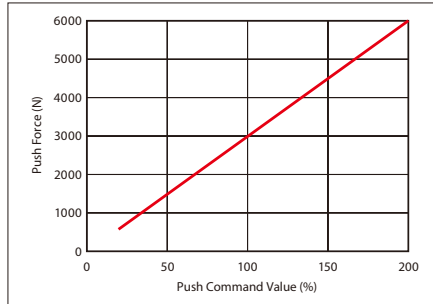

### Caution:

- The correlation between push force and push command value are strictly for reference purposes. Actual numbers may vary slightly.
- The push command value should be 20% or more because the push force will be unstable when the push command value is low.

**POINT Selection Notes**

- (1) For push-motion operation, check the allowable time period of continuous push-motion set with a different thrust force. Also, please check that the allowable continuous operational thrust force for the actual push cycle is less than the allowable continuous operational thrust force. (Even if there is no push motion) Please refer to P.28 for more information.
- (2) Customer's tooling is to be mounted on the load cell itself. In case any radial or moment load is applied to the load cell, please consider adding the external guides, etc. to offset those side loads.
- (3) Please install a support block when front mounting or back mounting a horizontally mounted actuator that is 150st or more. (Refer to page 34 "Notes When Installing")
- (4) Servo Press with load cell should not be used for pulling motion. It will damage the load cell.

## Actuator Specifications

### Lead and Payload

Model Number	Motor wattage (W)	Lead (mm)	Max. speed (mm/s)	Max. acceleration (G)	Max. payload		Rated thrust (N)	Max. push force (N)
					Horizontal (kg)	Vertical (kg)		
RCS3-RA10R-WA-400-2.5-①-T2-②-③	400	2.5	125	0.2	15	15	2713	6000

Legend: ① Stroke ② Cable Length ③ Option \* Max. horizontal payload means max. weight on the customer's external guide. \*\* Max. push force can be achieved only within 1~10mm/s speed range.

### Stroke and Max Speed

Lead (mm)	Stroke (mm)	100~500

(Unit: mm/s)

### ① Stroke

① Stroke (mm)	RCS3-RA10R
100	<input type="radio"/>
150	<input type="radio"/>
200	<input type="radio"/>
250	<input type="radio"/>
300	<input type="radio"/>
350	<input type="radio"/>
400	<input type="radio"/>
450	<input type="radio"/>
500	<input type="radio"/>

### ② Cable Length

Type	Cable Code
Standard	P(1m)
	S(3m)
	M(5m)
Specified length (Standard cable)	X06(6m) ~X10(10m)
	X11(11m)~X15(15m)
	X16(16m)~X20(20m)
	X16(16m)~X20(20m)
Robot cable	R01(1m) ~R03(3m)
	R04(4m) ~R05(5m)
	R06(6m) ~R10(10m)
	R11(11m)~R15(15m)
	R16(16m)~R20(20m)
	R16(16m)~R20(20m)

\* Please contact IAI for maintenance cables.

### ③ Options

Name	Option Code	Reference Page
Brake	B	See P.35
Cable exit direction (Top)	CJT	See P.35
Cable exit direction (Bottom) (*2)	CJB	See P.35
Cable exit direction (Outside)	CJO	See P.35
Flange (Front)	FL	See P.36
Foot bracket (*1)	FT	See P.37
Equipped with load cell (Standard equipment) (*3)	LCT	See P.37
Motor side-mounted (left)	ML	See P.37
Motor side-mounted (right)	MR	See P.37

(\*1) Refer to P. 37 for the number of brackets included.

(\*2) The foot bracket cannot be chosen when you select the actuator whose stroke is 100mm.

(\*3) Please make sure to enter "LCT" in the box of Model Specification Items to select the actuator with load cell option.

## Actuator Specifications

Item	Description
Drive system	Ball screw φ20mm rolled C10
Positioning repeatability	±0.01mm
Lost motion	0.1mm or less
Load cell rated capacity	6000N
Loading repeatability (*4)	±0.5% F.S (*5)
Ambient operating temp. & humidity	0°C~40°C, 85% RH or less (non-condensing)

(\*4) Ratio (in percentage) of the load variations caused by the repeated operations to the load cell rated capacity

(\*5) F.S.: Full Scale, the maximum measurable value.

Dimensions

CAD drawings can be downloaded from our website.  
www.intelligentactuator.com



\*1 Connect the motor-encoder cables. Please contact IAI for more details on the cable.  
\*2 While the rod is returning to its home position, please be careful of interference from surrounding objects, as it will travel until it reaches the mechanical end.  
M.E: Mechanical end  
S.E: Stroke end

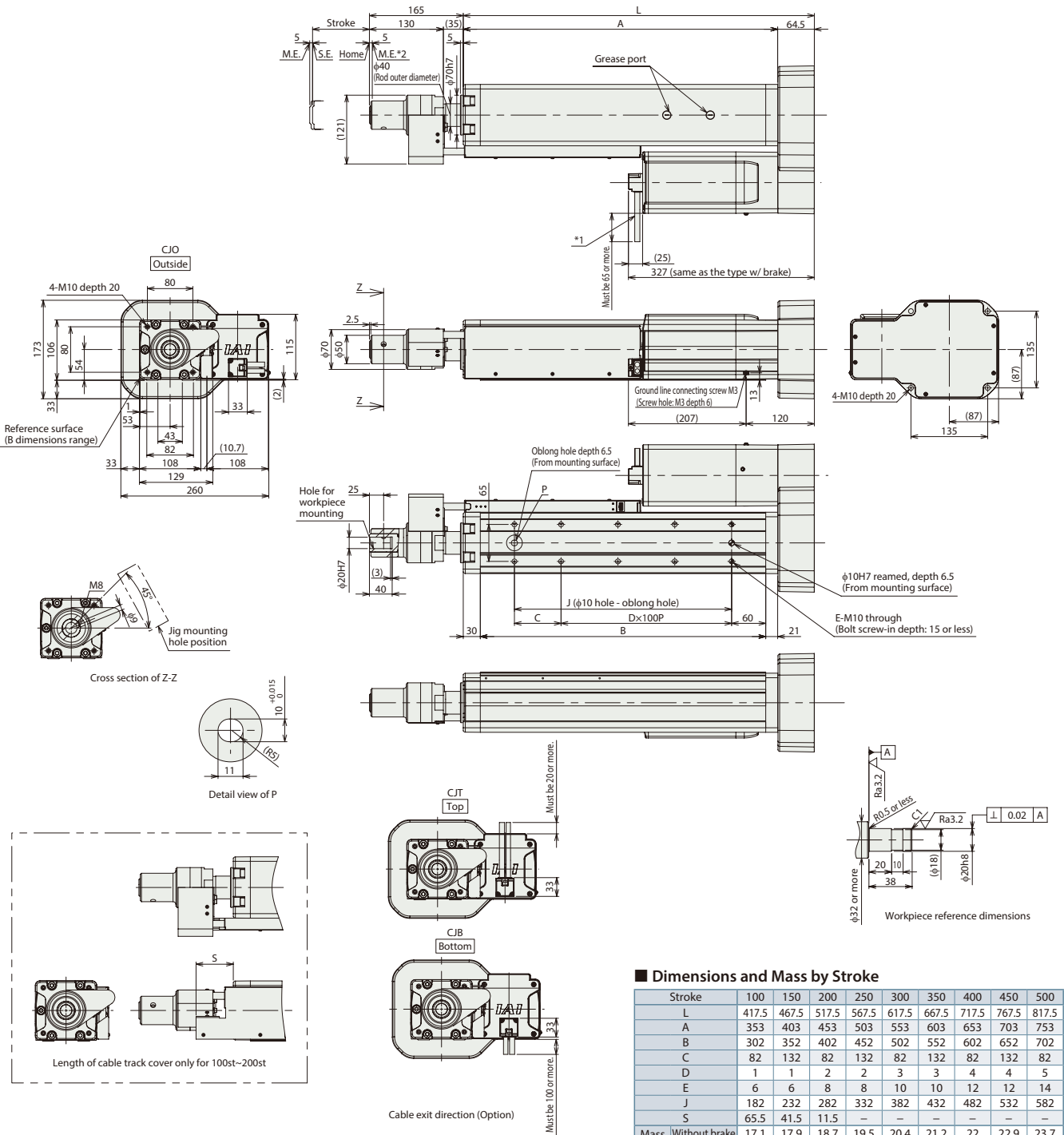

**■ Dimensions and Mass by Stroke**

Stroke	100	150	200	250	300	350	400	450	500
L	417.5	467.5	517.5	567.5	617.5	667.5	717.5	767.5	817.5
A	353	403	453	503	553	603	653	703	753
B	302	352	402	452	502	552	602	652	702
C	82	132	82	132	82	132	82	132	82
D	1	1	2	2	3	3	4	4	5
E	6	6	8	8	10	10	12	12	14
J	182	232	282	332	382	432	482	532	582
S	65.5	41.5	11.5	—	—	—	—	—	—
Mass (kg)									
Without brake	17.1	17.9	18.7	19.5	20.4	21.2	22	22.9	23.7
With brake	17.6	18.4	19.2	20	20.9	21.7	22.5	23.4	24.2

Applicable Controllers

The RCS3 series actuators can be operated by the controllers indicated below. Please select the type depending on your intended use.

Name	External view	Max. number of connectable axes	Power supply voltage	Control method				Network * Option	Maximum number of positioning points	Reference page
				Positioner	Pulse train	Program	Press program			
SCON-CB/CGB (For servo press only)		1	Single-phase 200VAC	-	-	-	●	DeviceNet CC-Link EtherCAT EtherNet/IP CompoNet MIECHATROLINK EtherCAT	-	Please contact IAI for more information.

# RCS2-RA13R (Servo press specification)

Battery-less Absolute
Motor Unit Type
Side-mounted Motor
Body Width 130\* mm
200v AC Servo Motor

Model Specification Items	<b>RCS2</b>	<b>RA13R</b>	<b>WA</b>	<b>750</b>	<input type="checkbox"/>	<input type="checkbox"/>	<b>T2</b>	<input type="checkbox"/>	<input type="checkbox"/>
	Series	Type	Encoder Type	Motor Type	Lead	Stroke	Applicable Controllers	Cable Length	Options
			WA: Battery-less Absolute	750: Servo motor 750W	2.5:2.5mm 1.25:1.25mm	50: 50mm 200: 200mm (Every 50mm)	T2: SCON-CB/ CGB (For servo press only)	N : None P : 1m S : 3m M : 5m X□□ : Specified length R□□ : Robot cable	Refer to Options table below. * One of motor mount direction type needs to be selected from MT1/MT2/MT3/MR1/MR2/ML1/ML3.

\* Does not include a controller.  
 \* Please contact IAI for more information about the model specification items.  
 \* Body width does not include the width of the side-mounted motor.

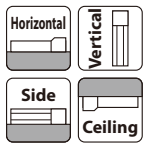

Depending on the model, there may be some limitations to using the vertical mount position. Please contact IAI for more information.

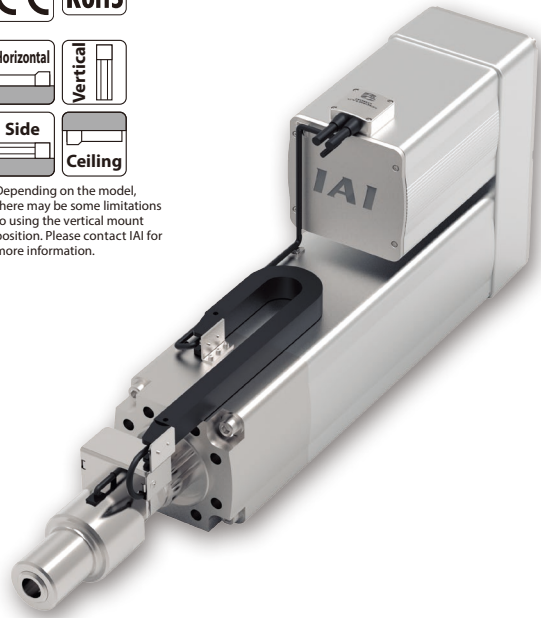

### Correlation Diagram of Push Force and Current Limit Value

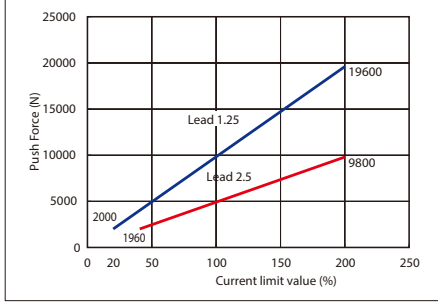

**Caution:**  
 ● The correlation between push force and current limit value is strictly for reference purposes. Actual numbers may vary slightly.  
 ● The push force will be unstable when the current limit value is low. Use at 20% or more for lead 1.25 and 40% or more for lead 2.5.

**POINT Selection Notes**

- For push-motion operation, check the allowable time period of continuous push-motion set with a different thrust force. Also, please check that the allowable continuous operational thrust force for the actual push cycle is less than the allowable continuous operational thrust force and that the duty cycle is 50% or less. Please refer to the Selection Guidelines (P.28) for more information.
- The value of payload is when operating at an acceleration of 0.02G for lead 2.5 and 0.01G for lead 1.25. The value listed above is the upper limit of acceleration.
- Customer's tooling is to be mounted on the load cell itself. In case any radial or moment load is applied to the load cell, please consider adding the external guides, etc. to offset those side loads. The value of the horizontal payload assumes that there is an external guide and that the rod is not subjected to external force other than in the moving direction.
- For the brake option, a brake box (see P.16) is required in addition to the main unit and controller.
- Servo Press with load cell should not be used for pulling motion. It will damage the load cell.

### Actuator Specifications

#### Lead and Payload

Model Number	Motor wattage (W)	Lead (mm)	Max. acceleration (G)	Max. payload		Rated thrust (N)	Max. push force (N)	Stroke (mm)
				Horizontal (kg)	Vertical (kg)			
RCS2-RA13R-WA-750-2.5-①-T2-②-③	750	2.5	0.02	15	15	5106	9800	50~200 (Every 50mm)
RCS2-RA13R-WA-750-1.25-①-T2-②-③		1.25	0.01	15	15	10211	19600	

Legend: ① Stroke ② Cable Length ③ Option \* Max. horizontal payload means max. weight on the customer's external guide. \*\* Max. push force can be achieved only within 1~10mm/s speed range.

#### Stroke and Max Speed

Lead (mm)	Stroke (mm)			
	50	100	150	200
2.5	85	120	125	
1.25	62			

(Unit: mm/s)

#### ① Stroke

① Stroke (mm)	RCS2-RA13R	
	1t Type (Lead 2.5)	2t Type (Lead 1.25)
50	○	○
100	○	○
150	○	○
200	○	○

#### ③ Options

Name	Option Code	Reference Page
Brake (With brake box)	<b>B</b>	See P.35
Brake (Without brake box)	<b>BN</b> *	See P.35
Flange (Front)	<b>FL</b>	See P.36
Foot bracket (*1)	<b>FT</b>	See P.37
With load cell (with cable track for wiring) (*2)	<b>LCT</b>	See P.37
With load cell (without cable track for wiring) (*2)	<b>LCN</b>	See P.37
Motor top side-mounted	<b>MT1/MT2/MT3</b>	See P.38
Motor right side-mounted	<b>MR1/MR2</b>	See P.38
Motor left side-mounted	<b>ML1/ML3</b>	See P.38

(\*1) Refer to P. 37 for the number of brackets included.  
 (\*2) Please make sure to select one of these for the load cell option (LCT/LCN) in the box of Model Specification Items.  
 (Note 1) Load cell option (with cable track for wiring) "LCT" and flange option "FL" cannot be selected together.  
 (Note 2) Option: When selecting the brake (without brake box) "BN" and using it as the second axis of the brake box, a cable must be separately purchased. Please refer to P.42 for more information.  
 (Note 3) Option: MR1/MR2/ML1/ML3 and FT cannot be selected together.

#### ② Cable Length

Type	Cable Code
Standard	<b>P</b> (1m)
	<b>S</b> (3m)
	<b>M</b> (5m)
Specified length (Standard cable)	<b>X06</b> (6m) ~ <b>X10</b> (10m)
	<b>X11</b> (11m) ~ <b>X15</b> (15m)
	<b>X16</b> (16m) ~ <b>X20</b> (20m)
Robot cable	<b>R01</b> (1m) ~ <b>R03</b> (3m)
	<b>R04</b> (4m) ~ <b>R05</b> (5m)
	<b>R06</b> (6m) ~ <b>R10</b> (10m)
	<b>R11</b> (11m) ~ <b>R15</b> (15m)
	<b>R16</b> (16m) ~ <b>R20</b> (20m)

\* Please contact IAI for maintenance cables.

### Actuator Specifications

Item	Description
Drive system	Ball screw φ32mm rolled C10
Positioning repeatability	±0.01mm
Lost motion	0.2mm or less
Load cell rated capacity	20000N
Loading repeatability (*3)	±0.5% F.S (*4)
Ambient operating temp. & humidity	0~40°C, 85% RH or less (non-condensing)

(\*3) Ratio (in percentage) of the load variations caused by the repeated operations to the load cell rated capacity  
 (\*4) F.S.: Full Scale, the maximum measurable value.



Dimensions

CAD drawings can be downloaded from our website.  
www.intelligentactuator.com



- \*1. Connect the motor-encoder cables. Please contact IAI for more details on the cable.
- \*2. While the rod is returning to its home position, please be careful of interference from surrounding objects, as it will travel until it reaches the mechanical end.  
M.E: Mechanical end S.E: Stroke end
- \*3. The direction of width across flats varies depending on the product. Flats cannot be used for vertical or horizontal reference planes.

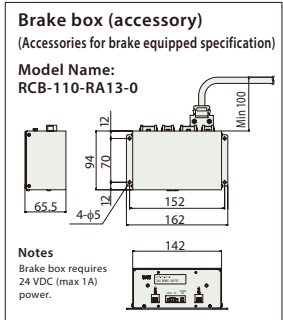
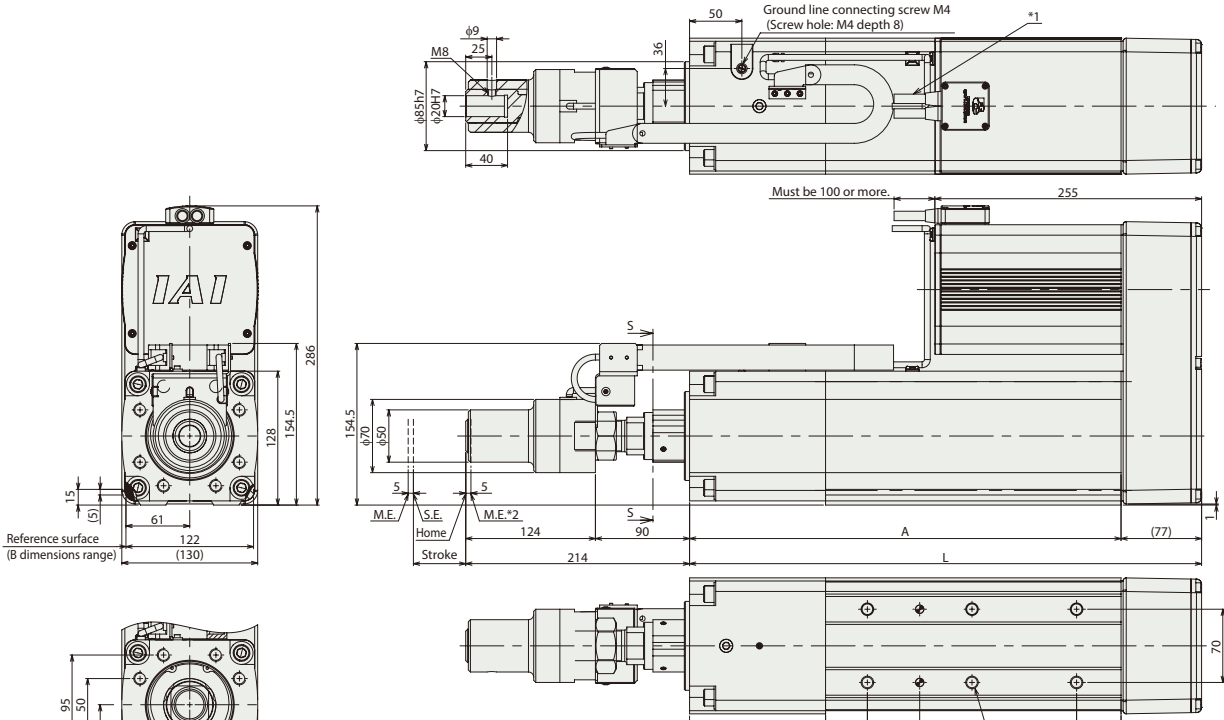

Notes  
Brake box requires 24 VDC (max 1A) power.

**Notes**  
The specification with brake (option model name "-B") always comes with a brake box. To purchase only the actuator body with brake, select the option model name "-BN".

Dimensions and Mass by Stroke

RCS2-RA13R  
\* The brake option has a 57mm longer total length and 2kg heavier weight.

Stroke	50	100	150	200
L	489.5	539.5	589.5	639.5
A	412.5	462.5	512.5	562.5
B	282.5	332.5	382.5	432.5
C	40	65	40	65
D	2	2	3	3
E	6	6	8	8
T	90	115	90	115
U	42.5	67.5	42.5	67.5
Mass (kg)	35.5	36.5	37.5	38.5

Side-mounted motor direction / Cable exit position (Option)

**Notes**  
Be sure to select a symbol in the model number for the side-mounted motor direction and cable exit position.

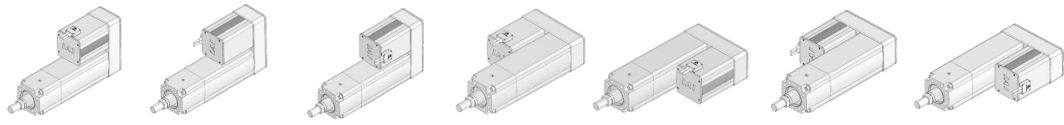

Option Code	MT1	MT2	MT3	MR1	ML1	MR2	ML3
Side-mounted motor direction	Top (standard)	Top	Top	Right side	Left side	Right side	Left side
Cable exit position	Top (standard)	Right side	Left side	Top	Top	Right side	Left side

Applicable Controllers

The RCS2 series actuators can be operated by the controllers indicated below. Please select the type depending on your intended use.

Name	External view	Max. number of connectable axes	Power supply voltage	Control method					Maximum number of positioning points	Reference page
				Positioner	Pulse train	Program	Press program	Network * Option		
SCON-CB/CGB (For servo press only)		1	Single-phase 200VAC	-	-	-	●	DeviceNet CC-Link CompoNet MIECHATROLINK EtherCAT EtherNet/IP	-	Please contact IAI for more information.

# RCS3-RA15R (Servo press specification)

Battery-less Absolute
Motor Unit Type
Side-mounted Motor
Body Width 150\* mm
200v AC Servo Motor

■ Model Specification Items	<b>RCS3</b>	—	<b>RA15R</b>	—	<b>WA</b>	—	<b>3300</b>	—	<b>3.6</b>	—		—	<b>T3</b>	—		—	
	Series	Type	Encoder Type	Motor Type	Lead	Stroke	Applicable Controllers	Cable Length	Options								
		WA: Battery-less Absolute		3300: Servo motor 3300W	3.6: Lead 3.6mm	100: 100mm 500: 500mm (Every 100mm)	T3: SCON-CGB (For servo press only)	N : None P : 1m S : 3m M : 5m X□□ : Specified length	Refer to Options table below. * Make sure to specify MT (Side-mounted motor on top).								

\* Does not include a controller.  
 \* Please contact IAI for more information about the model specification items.  
 \* Body width does not include the width of the side-mounted motor.

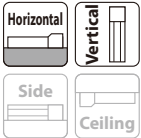

\* Depending on the model, there may be some limitations to using the vertical mount position. Please contact IAI for more information.

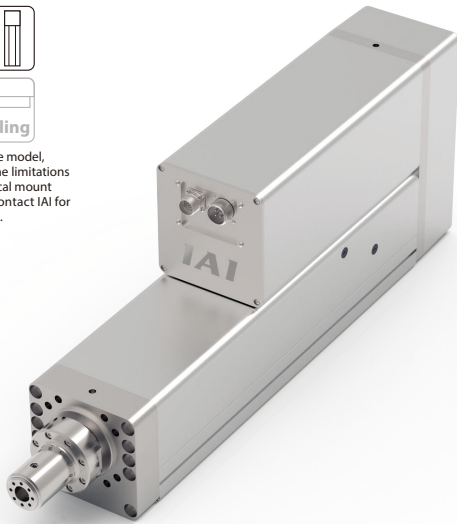

## ■ Correlation Diagram of Push Force and Current Limit Value

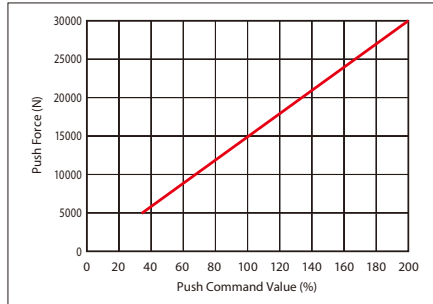

### Caution:

- The correlation between push force and push command value are strictly for reference purposes. Actual numbers may vary slightly.
- The push command value should be 34% or more because the push force will be unstable when the push command value is low.

- POINT Selection Notes**
- (1) For push-motion operation, check the allowable time period of continuous push-motion set with a different thrust force. Also, please check that the allowable continuous operational thrust force for the actual push cycle is less than the allowable continuous operational thrust force. (Even if there is no push motion) Please refer to P.28 for more information.
  - (2) Customer's tooling is to be mounted on the load cell itself. In case any radial or moment load is applied to the load cell, please consider adding the external guides, etc. to offset those side loads.
  - (3) Please install a support block when front mounting a horizontally mounted actuator. (Refer to page 34 "Notes When Installing")
  - (4) Servo Press with load cell should not be used for pulling motion. It will damage the load cell.
  - (5) The maximum payload for vertical mounting is 220kg when using the M5 tapped mounting hole at the tip of the load cell. When using the M8 tapped mounting hole on the side of the load cell tip and fixing with a setscrew, the payload should be 15 kg or less. Use either the M8 or M5 tapped mounting hole but not both.

## ■ Actuator Specifications

■ Lead and Payload								■ Stroke and Max Speed			
Model Number	Motor wattage (W)	Lead (mm)	Max. speed (mm/s)	Max. acceleration (G)	Max. payload		Rated thrust (N)	Max. push force (N)	Stroke (mm)	100~500	
					Horizontal (kg)	Vertical (kg)					
RCS3-RA15R-WA-3300-3.6-①-T3-②-③	3300	3.6	240	0.1	15	220	15577	30000	3.6	240	

Legend: ① Stroke ② Cable Length ③ Option \* Max. horizontal payload means max. weight on the customer's external guide. \*\* Max. push force can be achieved only within 1~10mm/s speed range. (Unit: mm/s)

### ① Stroke

① Stroke (mm)	RCS3-RA15R
100	○
200	○
300	○
400	○
500	○

### ② Cable Length

Type	Cable Code
Standard (Robot cable)	P(1m)
	S(3m)
	M(5m)
Specified length (Robot cable)	X06(6m)~X10(10m)
	X11(11m)~X15(15m)
	X16(16m)~X20(20m)

\* Please refer to P.49 for maintenance cables.  
\* Robot cable specification is standard.

### ③ Options

Name	Option Code	Reference Page
Brake	B	See P.35
Cable exit direction (Top)	CJT	See P.35
Cable exit direction (Right)	CJR	See P.35
Cable exit direction (Left)	CJL	See P.35
Equipped with load cell (Standard equipment) (*1)	LCT	See P.37
Side-mounted motor direction (Top)	MT	See P.37

(\*1) Please make sure to enter "LCT" in the box of Model Specification Items to select the actuator with load cell option.

### ■ Actuator Specifications

Item	Description
Drive system	Ball screw φ36mm ground
Positioning repeatability	±0.01mm
Lost motion	0.1mm or less
Load cell rated capacity	50000N
Loading repeatability (*2)	±0.5% F.S (*3)
Ambient operating temp. & humidity	0°C~40°C, 85% RH or less (non-condensing)

(\*2) Ratio (in percentage) of the load variations caused by the repeated operations to the load cell rated capacity  
(\*3) F.S.: Full Scale, the maximum measurable value.

Dimensions

CAD drawings can be downloaded from our website.  
www.intelligentactuator.com



- \*1 Connect the motor-encoder cables. Please contact IAI for more details on the cable.
- \*2 While the rod is returning to its home position, please be careful of interference from surrounding objects, as it will travel until it reaches the mechanical end.
- M.E: Mechanical end
- S.E: Stroke end

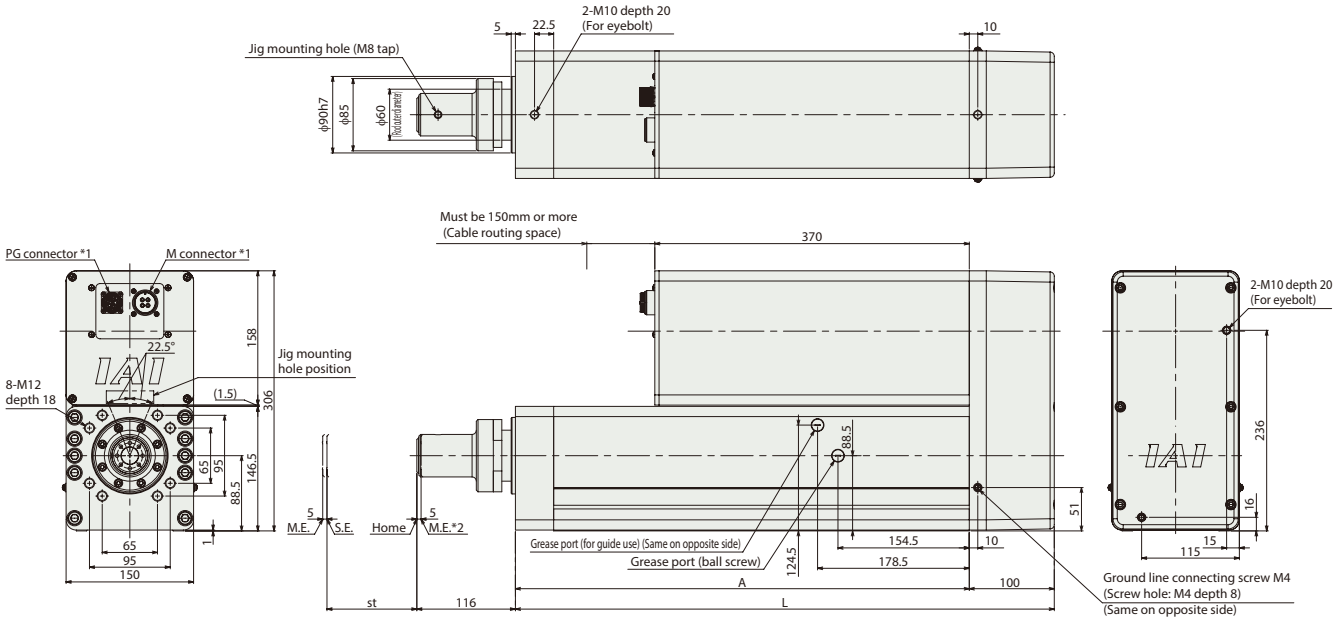

■ Dimensions with Brake

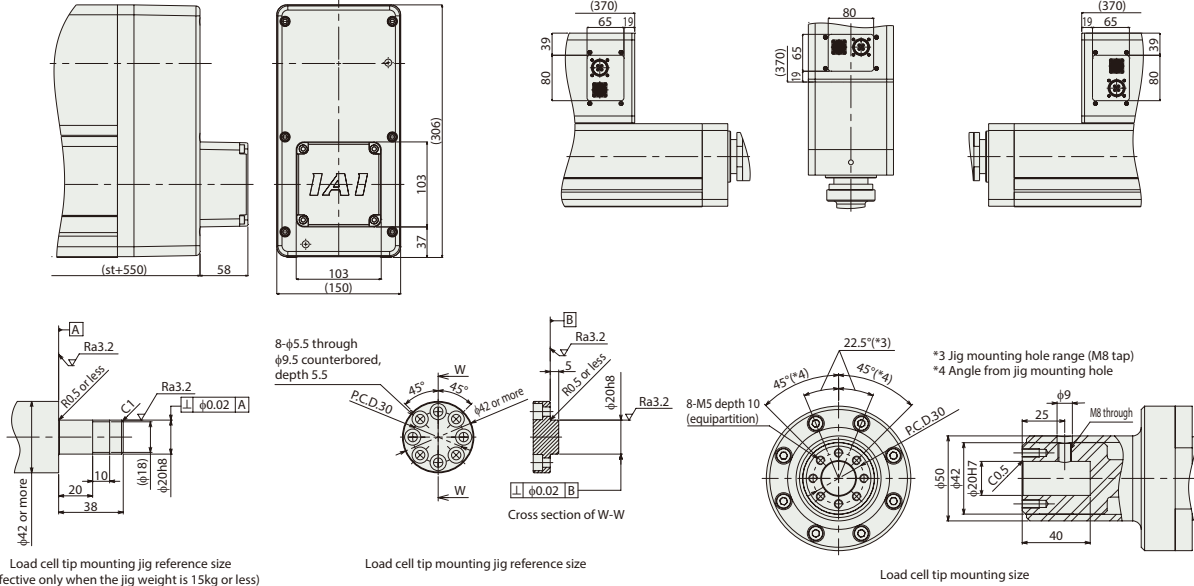

■ Dimensions and Mass by Stroke

Stroke	100	200	300	400	500	
L	534	634	734	834	934	
A	434	534	634	734	834	
Mass (kg)	Without brake	61	64.9	68.7	72.6	76.5
	With brake	63	66.9	70.7	74.6	78.5

Applicable Controllers

The RCS3 series actuators can be operated by the controllers indicated below. Please select the type depending on your intended use.

Name	External view	Max. number of connectable axes	Power supply voltage	Control method				Network * Option	Maximum number of positioning points	Reference page
				Positioner	Pulse train	Program	Press program			
SCON-CGB (For servo press only)		1	Three-phase 200VAC	-	-	-	●	DeviceNet CC-Link EtherCAT EtherNet/IP CompoNet MECHATROLINK EtherCAT EtherNet/IP	-	Please contact IAI for more information.

# RCS3-RA20R (Servo press specification)

Battery-less Absolute

Motor Unit Type

Side-mounted Motor

Body Width 200\* mm

200v AC Servo Motor

<b>Model Specification Items</b>	<b>RCS3</b>	<b>RA20R</b>	<b>WA</b>	<b>3000</b>	<b>4</b>		<b>T3</b>		
	Series	Type	Encoder Type	Motor Type	Lead	Stroke	Applicable Controllers	Cable Length	Options
			WA: Battery-less Absolute	3000: Servo motor 3000W	4: Lead 4mm	100: 100mm 500: 500mm (Every 100mm)	T3: SCON-CGB (For servo press only)	N : None P : 1m S : 3m M : 5m X□□ : Specified length	Refer to Options table below. * Make sure to specify MT (Side-mounted motor on top).

\* Does not include a controller.  
 \* Please contact IAI for more information about the model specification items.  
 \* Body width does not include the width of the side-mounted motor.



\* Depending on the model, there may be some limitations to using the vertical mount position. Please contact IAI for more information.

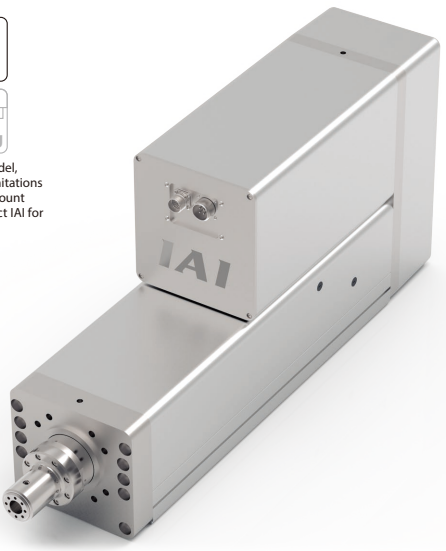

### Correlation Diagram of Push Force and Current Limit Value

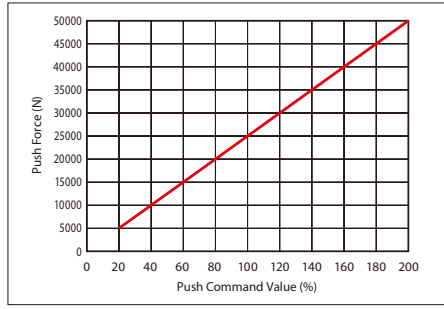

**Caution:**

- The correlation between push force and push command value are strictly for reference purposes. Actual numbers may vary slightly.
- The push command value should be 20% or more because the push force will be unstable when the push command value is low.

- POINT Selection Notes

  - (1) For push-motion operation, check the allowable time period of continuous push-motion set with a different thrust force. Also, please check that the allowable continuous operational thrust force for the actual push cycle is less than the allowable continuous operational thrust force. (Even if there is no push motion) Please refer to P.28 for more information.
  - (2) Customer's tooling is to be mounted on the load cell itself. In case any radial or moment load is applied to the load cell, please consider adding the external guides, etc. to offset those side loads.
  - (3) Please install a support block when front mounting a horizontally mounted actuator. (Refer to page 34 "Notes When Installing")
  - (4) Servo Press with load cell should not be used for pulling motion. It will damage the load cell.
  - (5) The maximum payload for vertical mounting is 220kg when using the M5 tapped mounting hole at the tip of the load cell. When using the M8 tapped mounting hole on the side of the load cell tip and fixing with a setscrew, the payload should be 15 kg or less. Use either the M8 or M5 tapped mounting hole but not both.

### Actuator Specifications

#### Lead and Payload

Model Number	Motor wattage (W)	Lead (mm)	Max. speed (mm/s)	Max. acceleration (G)	Max. payload		Rated thrust (N)	Max. push force (N)
					Horizontal (kg)	Vertical (kg)		
RCS3-RA20R-WA-3000-4-①-T3-②-③	3000	4	220	0.1	15	220	25902	50000

Legend: ① Stroke ② Cable Length ③ Option \* Max. horizontal payload means max. weight on the customer's external guide. \*\* Max. push force can be achieved only within 1~10mm/s speed range.

#### Stroke and Max Speed

Lead (mm)	Stroke (mm)	100~500
	4	

(Unit: mm/s)

#### ① Stroke

① Stroke (mm)	RCS3-RA20R
100	○
200	○
300	○
400	○
500	○

#### ② Cable Length

Type	Cable Code
Standard (Robot cable)	P(1m)
	S(3m)
	M(5m)
Specified length (Robot cable)	X06(6m)~X10(10m)
	X11(11m)~X15(15m)
	X16(16m)~X20(20m)

\* Please refer to P.49 for maintenance cables.  
\* Robot cable specification is standard.

#### ③ Options

Name	Option Code	Reference Page
Brake	<b>B</b>	See P.35
Cable exit direction (Top)	<b>CJT</b>	See P.35
Cable exit direction (Right)	<b>CJR</b>	See P.35
Cable exit direction (Left)	<b>CJL</b>	See P.35
Equipped with load cell (Standard equipment) (*1)	<b>LCT</b>	See P.37
Side-mounted motor direction (Top)	<b>MT</b>	See P.37

(\*1) Please make sure to enter "LCT" in the box of Model Specification Items to select the actuator with load cell option.

#### Actuator Specifications

Item	Description
Drive system	Ball screw φ40mm ground
Positioning repeatability	±0.01mm
Lost motion	0.1mm or less
Load cell rated capacity	50000N
Loading repeatability (*2)	±0.5% F.S (*3)
Ambient operating temp. & humidity	0°C~40°C, 85% RH or less (non-condensing)

(\*2) Ratio (in percentage) of the load variations caused by the repeated operations to the load cell rated capacity  
(\*3) F.S.: Full Scale, the maximum measurable value.

Dimensions

CAD drawings can be downloaded from our website.  
www.intelligentactuator.com



\*1 Connect the motor-encoder cables. Please contact IAI for more details on the cable.  
\*2 While the rod is returning to its home position, please be careful of interference from surrounding objects, as it will travel until it reaches the mechanical end.  
M.E: Mechanical end  
S.E: Stroke end

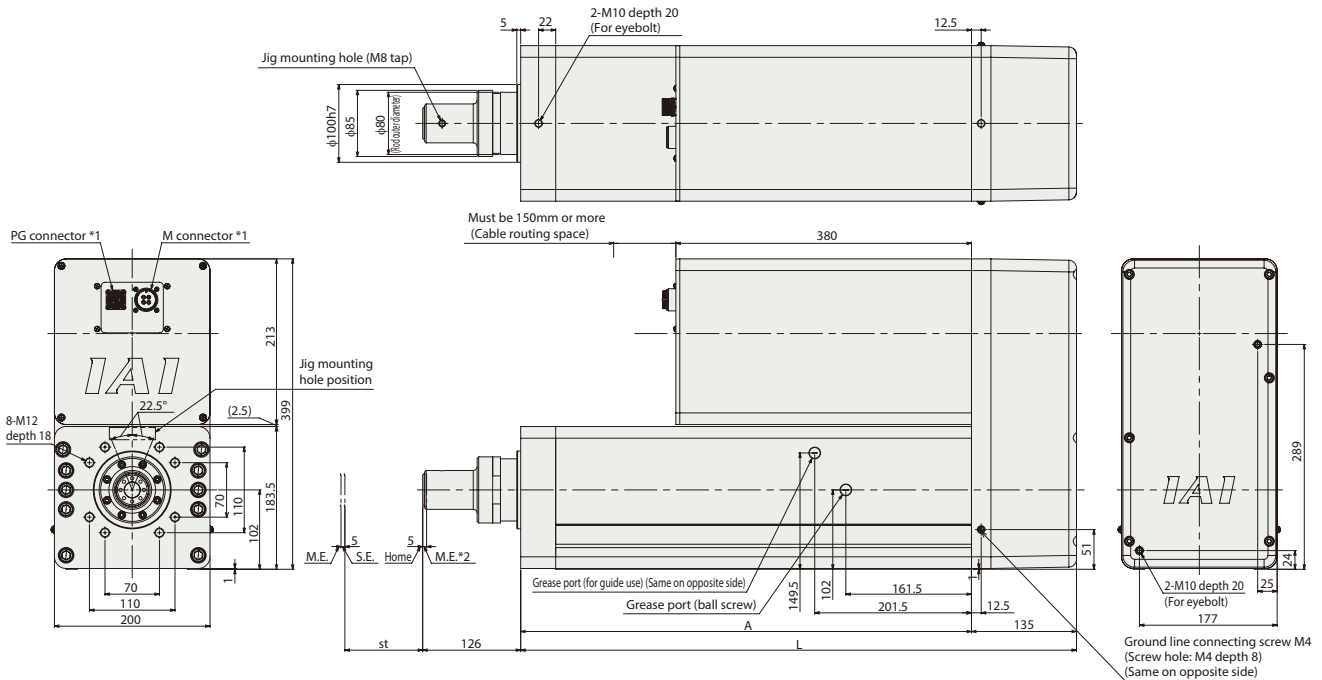

■ Dimensions with Brake

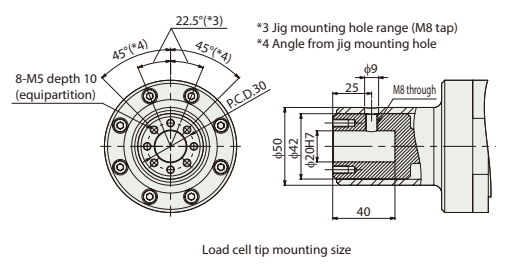
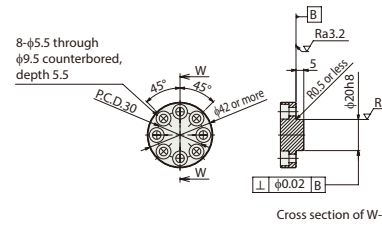
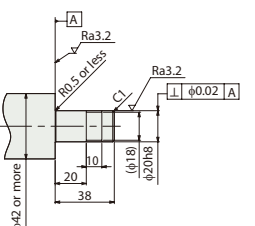
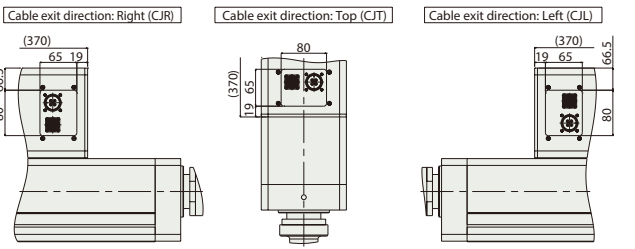
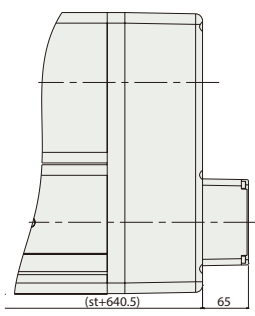

Load cell tip mounting jig reference size (Effective only when the jig weight is 15kg or less)

Load cell tip mounting jig reference size

■ Dimensions and Mass by Stroke

Stroke	100	200	300	400	500	
L	614.5	714.5	814.5	914.5	1014.5	
A	479.5	579.5	679.5	779.5	879.5	
Mass (kg)	Without brake	93.3	99.6	105.8	112.1	118.4
	With brake	96.3	102.6	108.8	115.1	121.4

Applicable Controllers

The RCS3 series actuators can be operated by the controllers indicated below. Please select the type depending on your intended use.

Name	External view	Max. number of connectable axes	Power supply voltage	Control method				Network * Option	Maximum number of positioning points	Reference page
				Positioner	Pulse train	Program	Press program			
SCON-CGB (For servo press only)		1	Three-phase 200VAC	-	-	-	●	DeviceNet CC-Link EtherCAT EtherNet/IP CompoNet MECHATROLINK EtherCAT EtherNet/IP	-	Please contact IAI for more information.

# RCS2-RA13R High-Payload Rod Type (Position Type without Load Cell)

Battery-less Absolute
Motor Unit Type
Side-mounted Motor
Body Width 130\* mm
200v AC Servo Motor

Model Specification Items	<b>RCS2</b>	<b>RA13R</b>	<b>WA</b>	<b>750</b>			<b>T2</b>		
	Series	Type	Encoder Type	Motor Type	Lead	Stroke	Applicable Controllers	Cable Length	Options
			WA: Battery-less Absolute	750: Servo motor 750W	2.5:2.5mm 1.25:1.25mm	50: 50mm 200: 200mm (Every 50mm)	T2: SCON SSEL XSEL-P/Q XSEL-RA/SA	N : None P : 1m S : 3m M : 5m X□□ : Specified length R□□ : Robot cable	Refer to Options table below. * One of motor mount direction type needs to be selected from MT1/MT2/MT3/MR1/MR2/ML1/ML3.

\* Does not include a controller.  
 \* Please contact IAI for more information about the model specification items.  
 \* Body width does not include the width of the side-mounted motor.

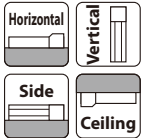

\* Depending on the model, there may be some limitations to using the vertical mount position. Please contact IAI for more information.

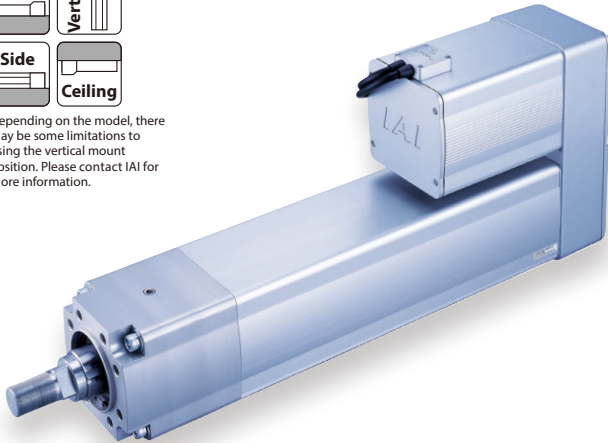

## Correlation Diagram of Push Force and Current Limit Value

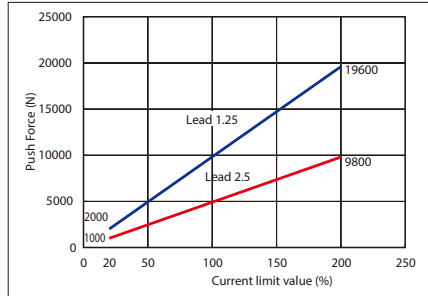

**Caution:**

- The correlation between push force and current limit value is strictly for reference purposes. Actual numbers may vary slightly.
- The current limit value should be 20% or more because the push force will be unstable when the current limit value is low.
- The travel speed during push-motion operation is fixed at 10mm/s. Please note that the graph shows push-motion at 10mm/s, and the push force will decrease as the speed changes.
- Depending on the operating conditions, the push force may decrease due to the temperature rise of the motor



- For push-motion operation, check the allowable time period of continuous push-motion set with a different thrust force. Also, please check that the allowable continuous operational thrust force for the actual push cycle is less than the allowable continuous operational thrust force and that the duty cycle is 50% or less. Please refer to the Selection Guidelines (P.28) for more information.
- The value of payload is when operating at an acceleration of 0.02G for lead 2.5 and 0.01G for lead 1.25. The value listed above is the upper limit of acceleration.
- Estimated allowable duty varies depending on operating conditions (payload, acceleration/deceleration, etc.). Please refer to P.31 for more information.
- The value of the horizontal payload assumes that there is an external guide and that the rod is not subjected to external force other than in the moving direction.
- Loads can be applied to the rod tip. Please refer to P.33 for more information.
- For the brake option, a brake box (see P.22) is required in addition to the main unit and controller.

## Actuator Specifications

### Lead and Payload

Model Number	Motor wattage (W)	Lead (mm)	Max. acceleration (G)	Max. payload		Rated thrust (N)	Max. push force (N)	Stroke (mm)
				Horizontal (kg)	Vertical (kg)			
RCS2-RA13R-WA-750-2.5-①-T2-②-③	750	2.5	0.02	400	200	5106	9800	50~200 (Every 50mm)
RCS2-RA13R-WA-750-1.25-①-T2-②-③		1.25	0.01	500	300	10211		

Legend: ① Stroke ② Cable Length ③ Option \* Max. horizontal payload means max. weight on the customer's external guide.  
 \*\* Max. push force can be achieved only within 5~10mm/s speed range.

### Stroke and Max Speed

Lead (mm)	Stroke (mm)			
	50	100	150	200
2.5	85	120	125	
1.25	62			

(Unit: mm/s)

### ① Stroke

① Stroke (mm)	RCS2-RA13R	
	1t Type (Lead 2.5)	2t Type (Lead 1.25)
50	○	○
100	○	○
150	○	○
200	○	○

### ② Cable Length

Type	Cable Code
Standard	P(1m)
	S(3m)
	M(5m)
Specified length (Standard cable)	X06(6m) ~X10(10m)
	X11(11m)~X15(15m)
	X16(16m)~X20(20m)
Robot cable	R01(1m) ~R03(3m)
	R04(4m) ~R05(5m)
	R06(6m) ~R10(10m)
	R11(11m)~R15(15m)
	R16(16m)~R20(20m)

\* Please contact IAI for maintenance cables.

### ③ Options

Name	Option Code	Reference Page
Brake (With brake box)	B	See P.35
Brake (Without brake box)	BN (*1)	See P.35
Flange	FL	See P.36
Foot Bracket	FT (*2)	See P.37
Motor top side-mounted	MT1/MT2/MT3	See P.38
Motor right side-mounted	MR1/MR2 (*2)	See P.38
Motor left side-mounted	ML1/ML3 (*2)	See P.38

(\*1) Option: When selecting the brake (without brake box) "BN" and using it as the second axis of the brake box, a cable must be separately purchased. Please refer to P.42 for more information.

(\*2) Option: MR1/MR2/ML1/ML3 and FT cannot be selected together.

## Actuator Specifications

Item	Description
Drive system	Ball screw φ32mm rolled C10
Positioning repeatability	±0.01mm
Backlash	0.2mm or less
Rod diameter	φ50mm (ball spline)
Allowable moment load to rod	120N·m Please see P.33
Ambient operating temp. & humidity	0~40°C, 85% RH or less (non-condensing)

## Dimensions

CAD drawings can be downloaded from our website.  
www.intelligentactuator.com



- \*1. Connect the motor-encoder cables. Please contact IAI for more details on the cable.
- \*2. While the rod is returning to its home position, please be careful of interference from surrounding objects, as it will travel until it reaches the mechanical end.
- M.E: Mechanical end S.E: Stroke end
- \*3. The direction of width across flats varies depending on the product. Those flats cannot be used for vertical or horizontal reference plane.

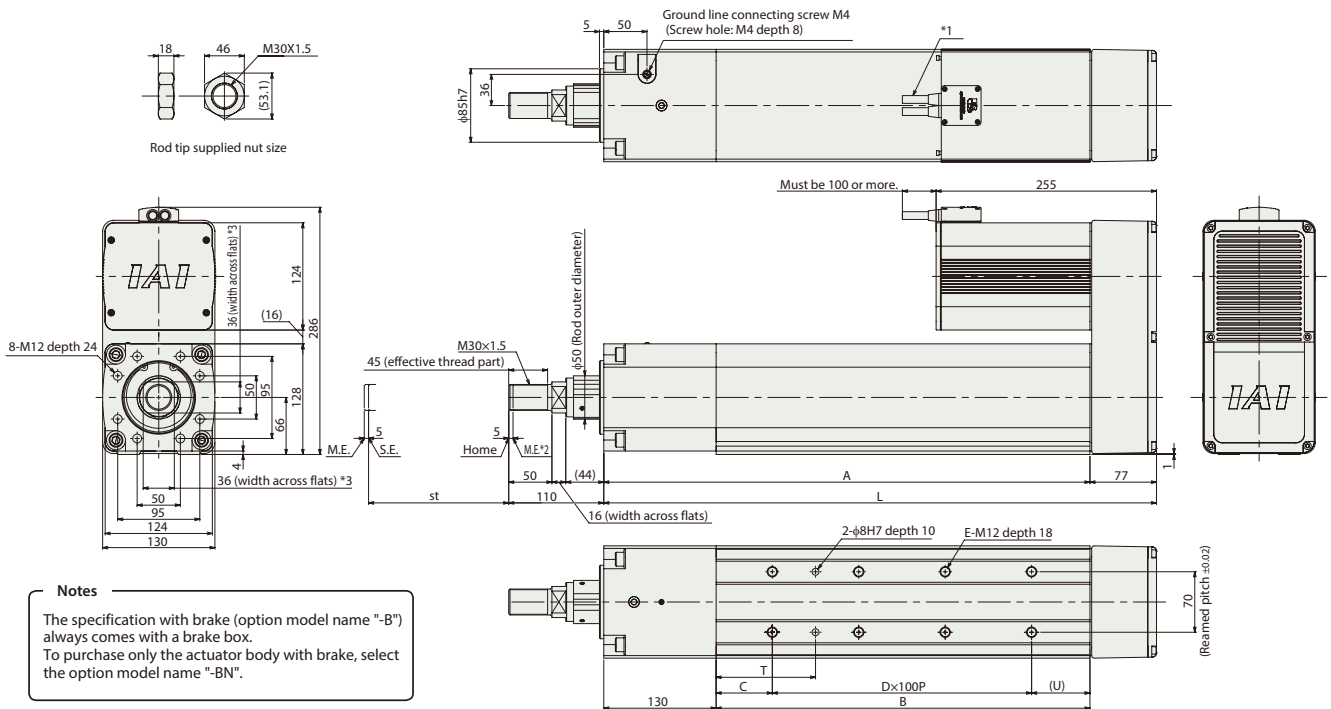

### Notes

The specification with brake (option model name "-B") always comes with a brake box. To purchase only the actuator body with brake, select the option model name "-BN".

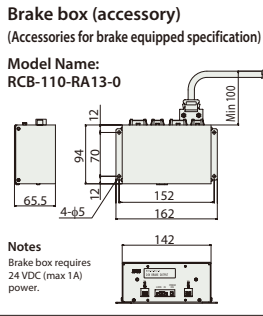
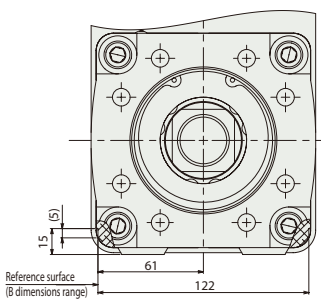

### Dimensions with Brake

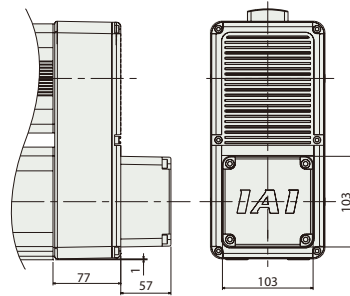

### Dimensions and Mass by Stroke

RCS2-RA13R  
\*The brake option has a 57mm longer total length and 2kg heavier weight.

Stroke	50	100	150	200
L	489.5	539.5	589.5	639.5
A	412.5	462.5	512.5	562.5
B	282.5	332.5	382.5	432.5
C	40	65	40	65
D	2	2	3	3
E	6	6	8	8
T	90	115	90	115
U	42.5	67.5	42.5	67.5
Mass (kg)	33	34	35	36

## Side-mounted motor direction / Cable exit position (Option)

### Notes

Be sure to select a symbol in the model number for the side-mounted motor direction and cable exit position.

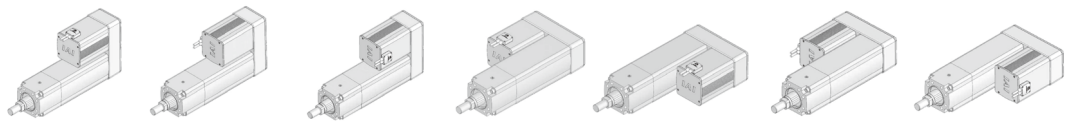

Option Code	MT1	MT2	MT3	MR1	ML1	MR2	ML3
Side-mounted motor direction	Top (standard)	Top	Top	Right side	Left side	Right side	Left side
Cable exit position	Top (standard)	Right side	Left side	Top	Top	Right side	Left side

## Applicable Controllers

The RCS2 series actuators can be operated by the controllers indicated below. Please select the type depending on your intended use.

Name	External view	Max. number of connectable axes	Power supply voltage	Control method			Network * Option	Maximum number of positioning points	Reference page
				Positioner	Pulse train	Program			
SCON-CB/CGB		1	Single-phase 200VAC	●	●	-	DeviceNet CC-Link PROFINET EtherCAT EtherNet/IP	512 (768 for network spec.)	Please contact IAI for more information.
SCON-LC/LCG		1		-	-	●		512 (768 for network spec.)	
SSEL-CS		2		●	-	●		20000	
XSEL-P/Q/RA/SA		8	Three-phase 200VAC	-	-	●	55,000 (Depending on the type)		

Note:  
The type of compatible networks will vary depending on the controller. Please refer to the reference page for more information.

# RCS3-RA15R High-Payload Rod Type (Position Type without Load Cell)

Battery-less Absolute
Motor Unit Type
Side-mounted Motor
Body Width 150\* mm
200v AC Servo Motor

Model Specification Items	<b>RCS3</b>	<b>RA15R</b>	<b>WA</b>	<b>3300</b>	<b>7.2</b>	<input type="checkbox"/>	<b>T3</b>	<input type="checkbox"/>	<input type="checkbox"/>
	Series	Type	Encoder Type	Motor Type	Lead	Stroke	Applicable Controllers	Cable Length	Options
			WA: Battery-less Absolute	3300: Servo motor 3300W	7.2: Lead 7.2mm	100: 100mm 500: 500mm (Every 100mm)	T3:SCON-CGB	N : None P : 1m S : 3m M : 5m X□□ : Specified length	Refer to Options table below. * Make sure to add MT (Side-mounted motor direction on top)

\* Does not include a controller.  
 \* Please contact IAI for more information about the model specification items.  
 \* Body width does not include the width of the side-mounted motor.

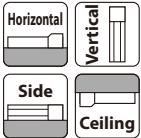

Depending on the model, there may be some limitations to using the vertical mount position. Please contact IAI for more information.

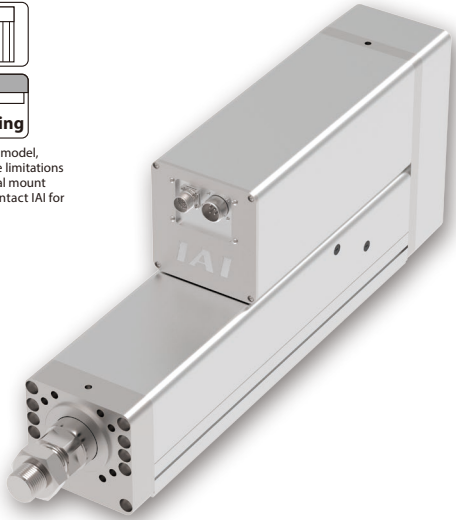

## Correlation Diagram of Push Force and Current Limit Value

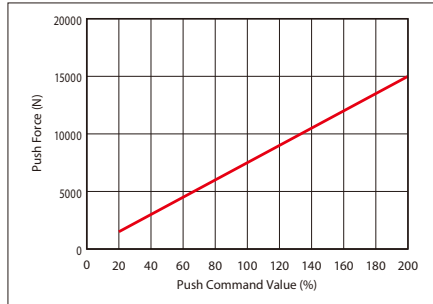

**Caution:**

- The correlation between push force and push command value are strictly for reference purposes. Actual numbers may vary slightly.
- The push command value should be 20% or more because the push force will be unstable when the push command value is low.



- For push-motion operation, check the allowable time period of continuous push-motion set with a different thrust force. Also, the estimated allowable duty varies depending on operating conditions (payload and speed). Please refer to P.31 for more information.
- Please install a support block when front mounting a horizontally mounted actuator. (Refer to page 34 "Notes When Installing")
- Loads can be applied to the rod tip. Please refer to P.33 for more information.

## Actuator Specifications

### Lead and Payload

Model Number	Motor wattage (W)	Lead (mm)	Max. speed (mm/s)	Max. acceleration (G)	Max. payload		Rated thrust (N)	Max. push force (N)
					Horizontal (kg)	Vertical (kg)		
RCS3-RA15R-WA-3300-7.2-①-T3-②-③	3300	7.2	400	0.2	700	400	7789	15000

Legend: ① Stroke ② Cable Length ③ Option \* Max. horizontal payload means max. weight on the customer's external guide. \*\* Max. push force can be achieved only within 5~10mm/s speed range.

### Stroke and Max Speed

Lead (mm)	Stroke (mm)	100~500

(Unit: mm/s)

### ① Stroke

① Stroke (mm)	RCS3-RA15R
100	<input type="radio"/>
200	<input type="radio"/>
300	<input type="radio"/>
400	<input type="radio"/>
500	<input type="radio"/>

### ② Cable Length

Type	Cable Code
Standard type (Robot cable)	P(1m)
	S(3m)
	M(5m)
Specified length (Robot cable)	X06(6m) ~X10(10m)
	X11(11m)~X15(15m)
	X16(16m)~X20(20m)

\* Please refer to P.49 for maintenance cables.  
\* Robot cable specification is standard.

### ③ Options

Name	Option Code	Reference Page
Brake	<b>B</b>	See P.35
Cable exit direction (Top)	<b>CJT</b>	See P.35
Cable exit direction (Right)	<b>CJR</b>	See P.35
Cable exit direction (Left)	<b>CJL</b>	See P.35
Side-mounted motor direction (Top)	<b>MT</b>	See P.37

### Actuator Specifications

Item	Description
Drive system	Ball screw φ36mm ground
Positioning repeatability	±0.01mm
Lost motion	0.1mm or less
Allowable moment load to rod	Please see P. 33
Ambient operating temp. & humidity	0°C~40°C, 85% RH or less (non-condensing)



Dimensions

CAD drawings can be downloaded from our website.  
www.intelligentactuator.com



- \*1 Connect the motor-encoder cables. Please contact IAI for more details on the cable.
- \*2 While the rod is returning to its home position, please be careful of interference from surrounding objects, as it will travel until it reaches the mechanical end.  
M.E: Mechanical end S.E.: Stroke end
- \*3 The direction of width across flats varies depending on the product. Those flats cannot be used for vertical or horizontal reference plane.

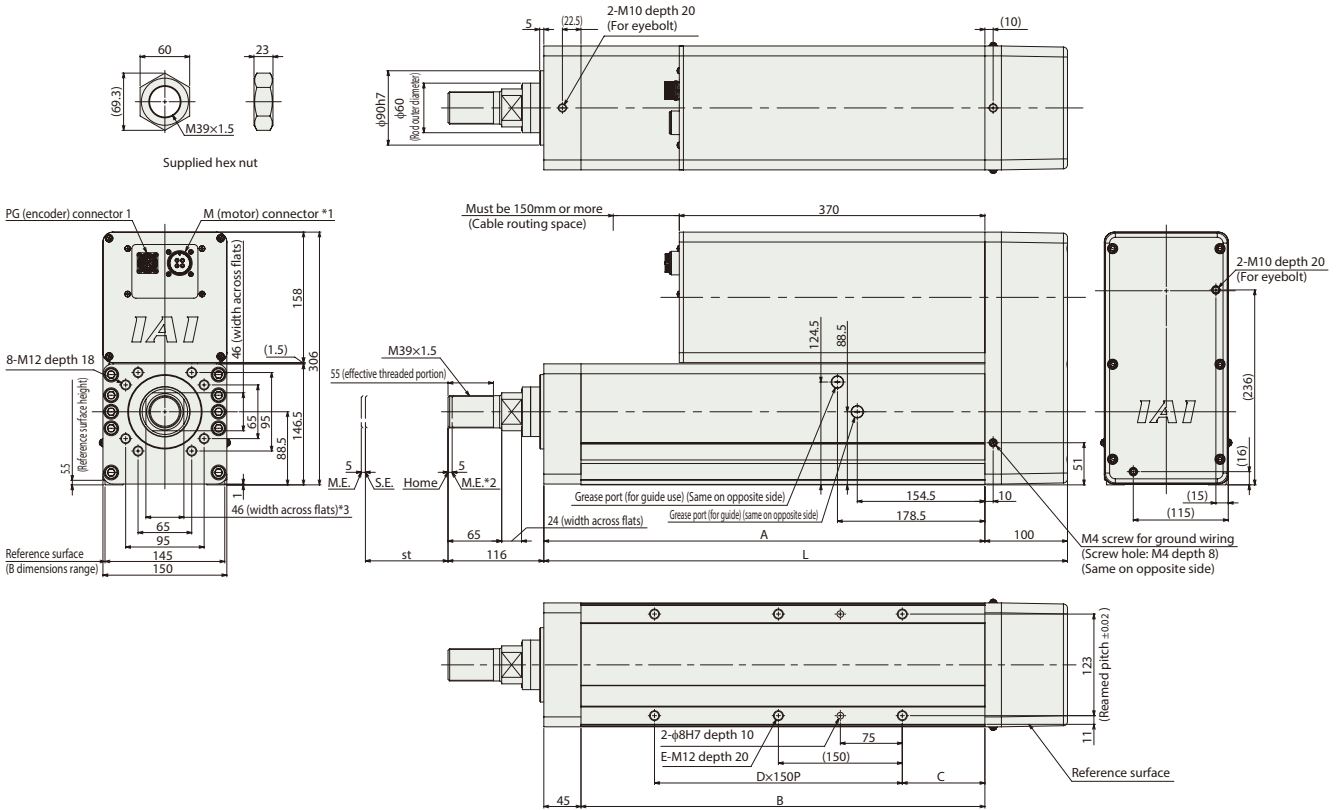

■ Dimensions with Brake

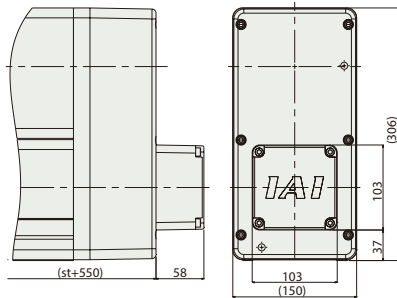

Cable exit direction: Right (CJR)

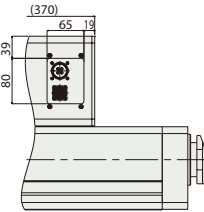

Cable exit direction: Top (CJT)

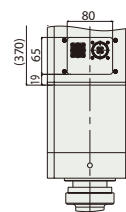

Cable exit direction: Left (CJL)

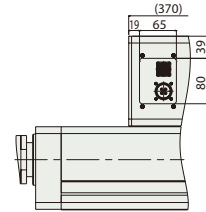

■ Dimensions and Mass by Stroke

Stroke	100	200	300	400	500	
L	534	634	734	834	934	
A	434	534	634	734	834	
B	389	489	589	689	789	
C	50	100	70	50	100	
D	2	2	3	4	4	
E	6	6	8	10	10	
Mass (kg)	Without brake	60	63.9	67.7	71.6	75.5
	With brake	62	65.9	69.7	73.6	77.5

Applicable Controllers

The RCS3 series actuators can be operated by the controllers indicated below. Please select the type depending on your intended use.

Name	External view	Max. number of connectable axes	Power supply voltage	Control method				Maximum number of positioning points	Reference page
				Positioner	Pulse train	Program	Network * Option		
SCON-CGB (for Position Controller)		1	Three-phase 200VAC	●	-	-	DeviceNet CC-Link EtherCAT EtherNet/IP CompoNet MECHATROLINK EtherCAT EtherNet/IP 	512 (768 for network spec.)	See P.40

# RCS3-RA20R High-Payload Rod Type (Position Type without Load Cell)

Battery-less Absolute
Motor Unit Type
Side-mounted Motor
Body Width 200\* mm
200v AC Servo Motor

■ Model Specification Items	<b>RCS3</b>	<b>RA20R</b>	<b>WA</b>	<b>3000</b>	<b>10</b>	<input type="checkbox"/>	<b>T3</b>	<input type="checkbox"/>	<input type="checkbox"/>
	Series	Type	Encoder Type	Motor Type	Lead	Stroke	Applicable Controllers	Cable Length	Options
			WA: Battery-less Absolute	3000: Servo motor 3000W	10: Lead 10mm	100: 100mm ? 500: 500mm (Every 100mm)	T3:SCON-CGB	N : None P : 1m S : 3m M : 5m X□□ : Specified length	Refer to Options table below. * Make sure to specify MT (Side-mounted motor on top).

\* Does not include a controller.  
 \* Please contact IAI for more information about the model specification items.  
 \* Body width does not include the width of the side-mounted motor.

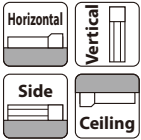

\* Depending on the model, there may be some limitations to using the vertical mount position. Please contact IAI for more information.

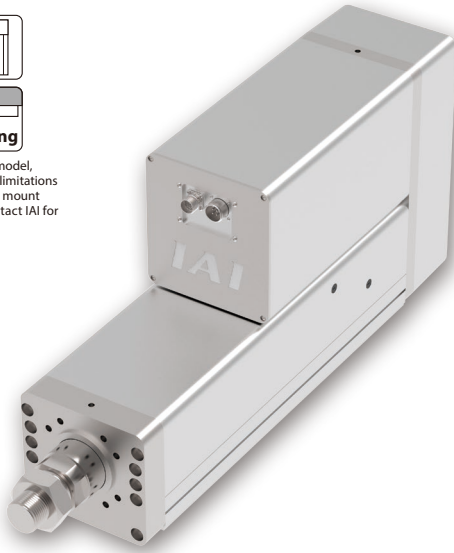

## ■ Correlation Diagram of Push Force and Current Limit Value

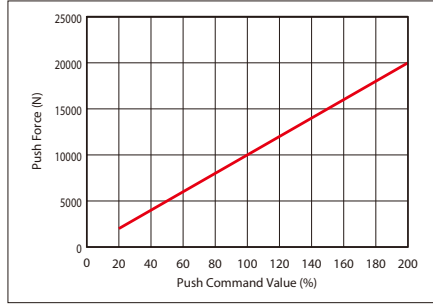

**Caution:**

- The correlation between push force and push command value are strictly for reference purposes. Actual numbers may vary slightly.
- The push command value should be 20% or more because the push force will be unstable when the push command value is low.

**POINT Selection Notes**

- (1) For push-motion operation, check the allowable time period of continuous push-motion set with a different thrust force. Also, the estimated allowable duty varies depending on operating conditions (payload and speed). Please refer to P.31 for more information.
- (2) Please install a support block when front mounting a horizontally mounted actuator. (Refer to page 34 "Notes When Installing")
- (3) Loads can be applied to the rod tip. Please refer to P.33 for more information.

## ■ Actuator Specifications

### ■ Lead and Payload

Model Number	Motor wattage (W)	Lead (mm)	Max. speed (mm/s)	Max. acceleration (G)	Max. payload		Rated thrust (N)	Max. push force (N)
					Horizontal (kg)	Vertical (kg)		
RCS3-RA20R-WA-3000-10-①-T3-②-③	3000	10	400	0.2	1000	600	10361	20000

Legend: ① Stroke ② Cable Length ③ Option \* Max. horizontal payload means max. weight on the customer's external guide. \*\* Max. push force can be achieved only within 5~10mm/s speed range.

### ■ Stroke and Max Speed

Lead (mm)	Stroke (mm)	100~500

(Unit: mm/s)

### ① Stroke

① Stroke (mm)	RCS3-RA20R
100	<input type="checkbox"/>
200	<input type="checkbox"/>
300	<input type="checkbox"/>
400	<input type="checkbox"/>
500	<input type="checkbox"/>

### ② Cable Length

Type	Cable Code
Standard type (Robot cable)	P(1m)
	S(3m)
	M(5m)
Specified length (Robot cable)	X06(6m) ~X10(10m)
	X11(11m)~X15(15m)
	X16(16m)~X20(20m)

\* Please refer to P.49 for maintenance cables.  
\* Robot cable specification is standard.

### ③ Options

Name	Option Code	Reference Page
Brake	<b>B</b>	See P.35
Cable exit direction (Top)	<b>CJT</b>	See P.35
Cable exit direction (Right)	<b>CJR</b>	See P.35
Cable exit direction (Left)	<b>CJL</b>	See P.35
Side-mounted motor direction (Top)	<b>MT</b>	See P.37

### ■ Actuator Specifications

Item	Description
Drive system	Ball screw φ40mm ground
Positioning repeatability	±0.01mm
Lost motion	0.1mm or less
Allowable moment to rod	Please see P. 33
Ambient operating temp. & humidity	0°C~40°C, 85% RH or less (non-condensing)

Dimensions

CAD drawings can be downloaded from our website.  
www.intelligentactuator.com



- \*1 Connect the motor-encoder cables. Please contact IAI for more details on the cable.
- \*2 While the rod is returning to its home position, please be careful of interference from surrounding objects, as it will travel until it reaches the mechanical end.  
M.E: Mechanical end S.E.: Stroke end
- \*3 The direction of width across flats varies depending on the product. Those flats cannot be used for vertical or horizontal reference plane.

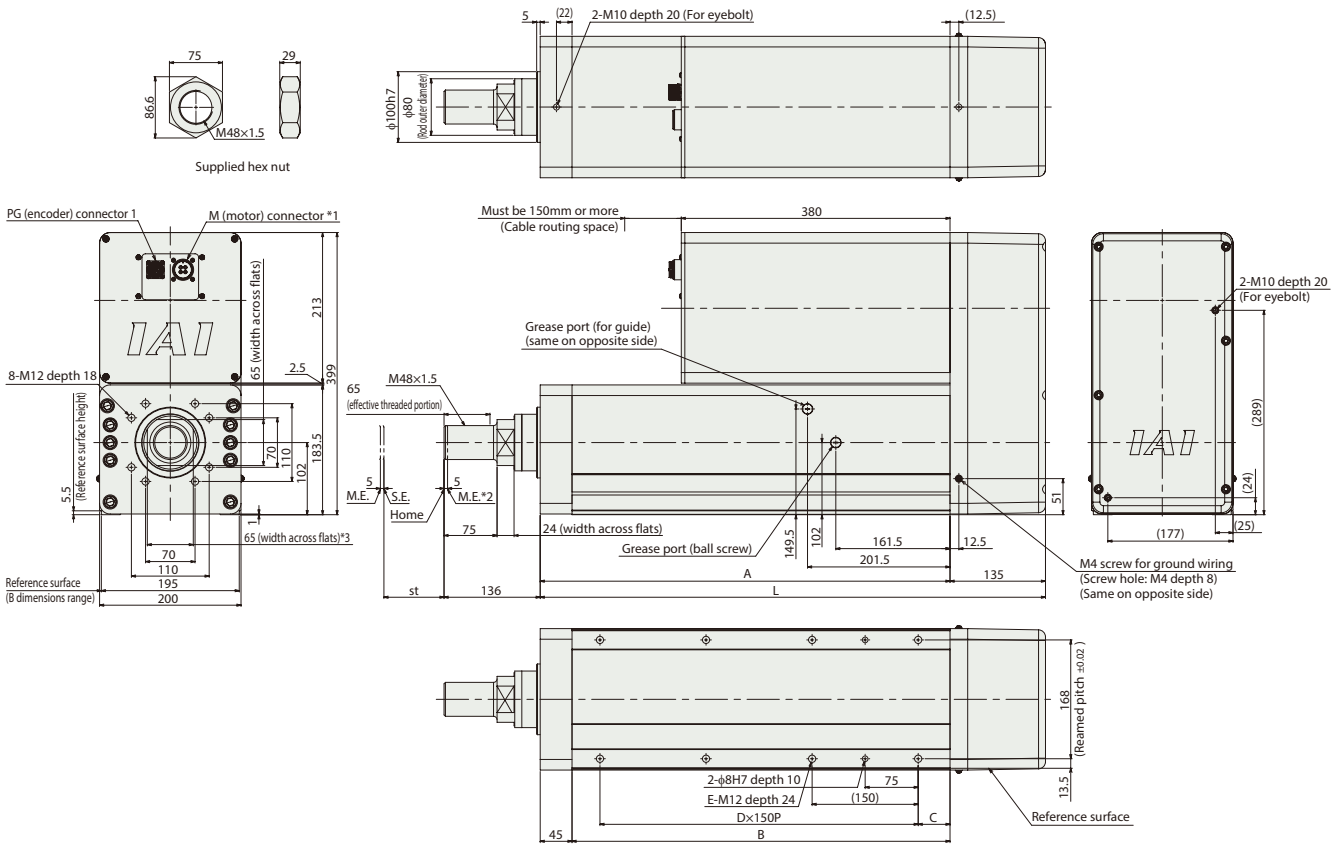

■ Dimensions with Brake

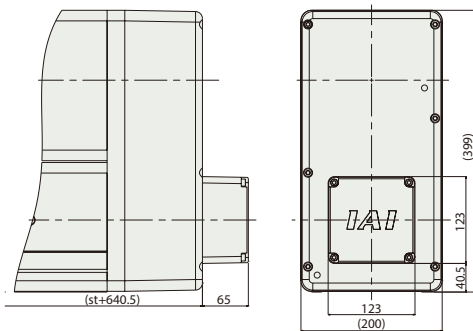

Cable exit direction: Right (CJR)

Cable exit direction: Top (CJT)

Cable exit direction: Left (CJL)

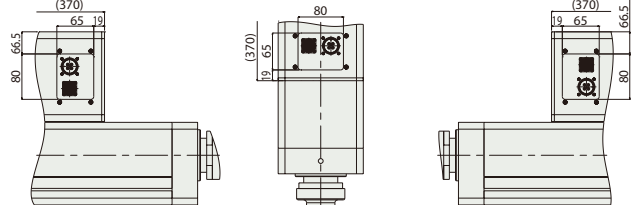

■ Dimensions and Mass by Stroke

Stroke	100	200	300	400	500	
L	614.5	714.5	814.5	914.5	1014.5	
A	479.5	579.5	679.5	779.5	879.5	
B	434.5	534.5	634.5	734.5	834.5	
C	70	45	100	70	120	
D	2	3	3	4	4	
E	6	8	8	10	10	
Mass (kg)	Without brake	93.3	99.6	105.8	112.1	118.4
	With brake	96.3	102.6	108.8	115.1	121.4

Applicable Controllers

The RCS3 series actuators can be operated by the controllers indicated below. Please select the type depending on your intended use.

Name	External view	Max. number of connectable axes	Power supply voltage	Control method				Maximum number of positioning points	Reference page
				Positioner	Pulse train	Program	Network * Option		
SCON-CGB (for Position Controller)		1	Three-phase 200VAC	●	-	-	DeviceNet CC-Link EtherCAT EtherNet/IP CompoNet MECHATROLINK EtherCAT EtherNet/IP CompoNet	512 (768 for network spec.)	See P.40

# Operating Conditions

RCS3/RCS2 Series Servo press specification (with load cell)

When using the actuator, the following three conditions must be satisfied.

- Condition 1.** The push time must be **the determined time or less**
- Condition 2.** The continuous operational thrust force of a single cycle must be **the allowable continuous operational thrust force or less**
- Condition 3.** In a single cycle, **push-motion operation must occur only once**

**Selection method**

**Condition 1. Push time**

The maximum push time of each push command value is determined in the tables below. When using the actuator, please make sure that the push time is the time indicated in the tables below or less. Please be aware that using the actuator beyond the time indicated in the tables below may cause the actuator to malfunction. Note that there are no limitations on the continuous push time for RA4R.

**RCS3**

**RA6R**

Push Command Value (%)	Maximum Push Time (s)
70 or less	Continuous pushing available
71~85	300
90	38
95	27
100	21

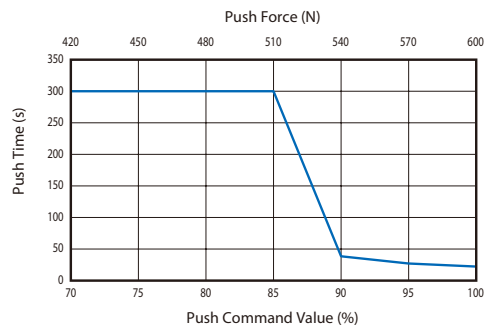

**RA7R**

Push Command Value (%)	Maximum Push Time (s)
70 or less	Continuous pushing available
71~80	300
85	94
90	33
95	24
100	18
105	15
110	12
115	11
120	9
125	8
130	7
135	6
140	5

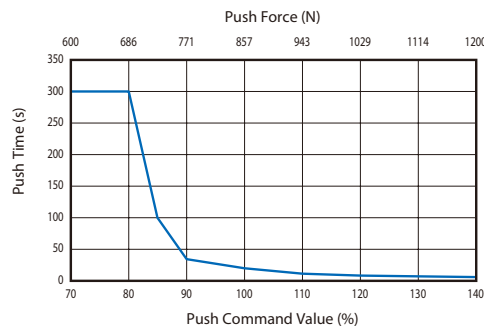

**RA8R**

Push Command Value (%)	Maximum Push Time (s)
70 or less	Continuous pushing available
71~100	300
105	92
110	67
115	54
120	44
125	38
130	33
135	29
140	25

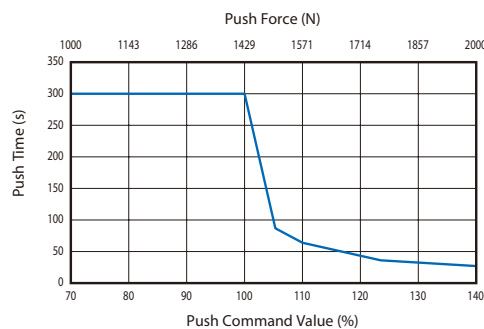

**RA10R**

Push Command Value (%)	Maximum Push Time (s)
70 or less	Continuous pushing available
71~90	300
95	210
100	95
105	70
110	56
115	46
120	39
125	34
130	30
135	26
140	24
145	21
150	19
155	17
160	16
165	14
170	13
175	12
180	11
185	10
190	9
195	9
200	8

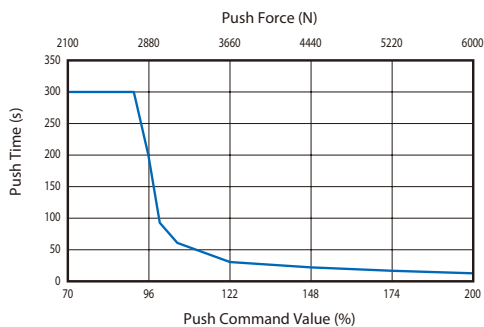

**RCS2**

**RA13R**

Push Command Value (%)	Maximum Push Time (s)
70 or less	(Continuous pushing is possible)
71~100	300
110	230
120	95
130	58
140	43
150	33
160	27
170	21
180	18
190	15
200	13

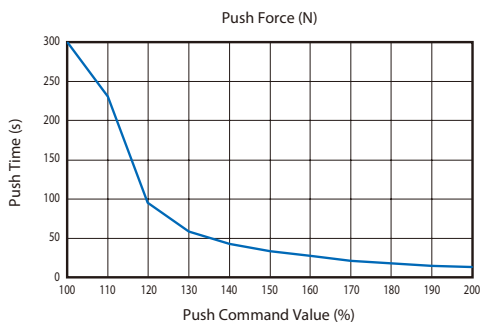

**RCS3**

**RA15R**

Push Command Value (%)	Maximum Push Time (s)
90 or less	Continuous pushing available
91~100	300
110	118
120	58
130	40
140	30
150	25
160	20
170	16
180	13
190	10
200	9

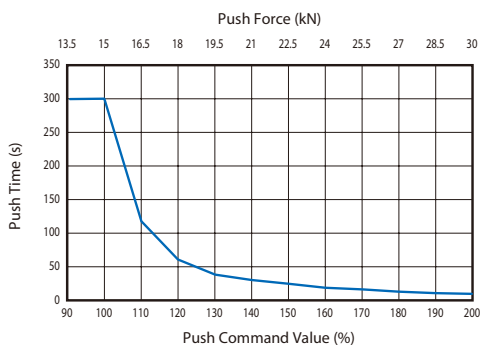

**RA20R**

Push Command Value (%)	Maximum Push Time (s)
90 or less	Continuous pushing available
91~100	300
110	80
120	50
130	36
140	28
150	22
160	18
170	15
180	13
190	11
200	10

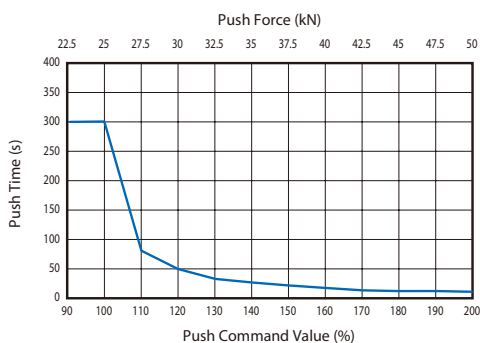

# Operating Conditions

RCS3/RCS2 Series Servo press specification (with load cell)

**Condition 2.** Continuous operational thrust force

Please consider that the load and duty cycle of a single continuous operational thrust force  $F_t$  must be smaller than the allowable continuous operational thrust force of the actuator. Also, **push-motion operation is performed only once** during a single cycle.

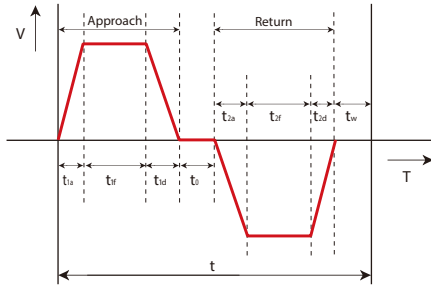

If the operation patterns on the left are rewritten so that thrust becomes the vertical axis

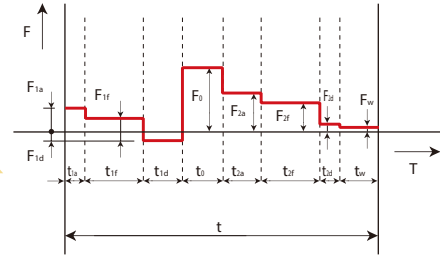

- $t$  : Operation time per cycle (s)
- $t_{1a}$  : Acceleration time 1
- $t_{1r}$  : Constant rate of traverse time 1
- $t_{1d}$  : Deceleration time 1
- $t_0$  : Push-motion operation time
- $t_{2a}$  : Acceleration time 2
- $t_{2r}$  : Constant rate of traverse time 2
- $t_{2d}$  : Deceleration time 2
- $t_w$  : Wait time

- $F_{1a}$  : Thrust necessary for acceleration 1
- $F_{1r}$  : Thrust necessary for constant traverse 1
- $F_{1d}$  : Thrust necessary for deceleration 1
- $F_0$  : Thrust necessary for push-motion operation
- $F_{2a}$  : Thrust necessary for acceleration 2
- $F_{2r}$  : Thrust necessary for constant traverse 2
- $F_{2d}$  : Thrust necessary for deceleration 2
- $F_w$  : Thrust necessary for waiting

The continuous operational thrust force  $F_t$  of a single cycle is calculated with the following formula.

$$F_t = \sqrt{\frac{F_{1a}^2 \times t_{1a} + F_{1r}^2 \times t_{1r} + F_{1d}^2 \times t_{1d} + F_0^2 \times t_0 + F_{2a}^2 \times t_{2a} + F_{2r}^2 \times t_{2r} + F_{2d}^2 \times t_{2d} + F_w^2 \times t_w}{t}}$$

•  $F_{1a}/F_{2a}/F_{1d}/F_{2d}$  vary according to the direction of operation, so please calculate them with the formulas shown below.

- In the case of horizontal use (acceleration/deceleration)
- Horizontal use For constant traverse
- Horizontal use In the wait state
- Vertical use In the case of acceleration during descent
- Vertical use In the case of constant traverse during descent
- Vertical use In the case of deceleration during descent
- Vertical use In the case of acceleration during ascent
- Vertical use In the case of constant traverse during ascent
- Vertical use In the case of deceleration during ascent
- Vertical use In the wait state

- $F_{1a} = F_{1d} = F_{2a} = F_{2d} = (M+m) \times d + F_s$
- $F_{1r} = F_{2r} = f + F_s$
- $F_w = 0$
- $F_{1a} = (M+m) \times 9.8 - (M+m) \times d + F_s$
- $F_{1r} = (M+m) \times 9.8 + \alpha (*1) + F_s$
- $F_{1d} = (M+m) \times 9.8 + (M+m) \times d + F_s$
- $F_{2a} = (M+m) \times 9.8 + (M+m) \times d + F_s$
- $F_{2r} = (M+m) \times 9.8 + \alpha (*1) + F_s$
- $F_{2d} = (M+m) \times 9.8 - (M+m) \times d + F_s$
- $F_w = (M+m) \times 9.8$

- $M$ : Weight of moving part (kg)
- $m$ : Weight of load (kg)
- $d$ : Directive acceleration/deceleration setting (m/s<sup>2</sup>)
- $\alpha$ : Thrust taking into account the driving resistance of the external guide
- $f$ : Driving resistance with an external guide or similar component installed (N)
- $F_s$ : Calculate the thrust for each speed from the table below for RA15R and 20R only

Actuator
Mass of moving part:
RA6R: 2.5kg
RA7R: 3.5kg
RA8R: 4kg
RA10R: 5kg
RA13R: 9kg
RA15R: 10kg
RA20R: 18kg

\*1 When an external guide or similar component is installed, it is necessary to take into account the driving resistance  $f$ .

RCS3-RA15R		RCS3-RA20R	
Speed [mm/s]	$F_s$ [N]	Speed [mm/s]	$F_s$ [N]
0~180	0	0~40	0
181~190	625	41~50	1875
191~200	1250	51~60	3750
201~210	1875	61~70	5625
211~220	2500	71~80	7500
221~230	3125	81~90	9375
231~240	3750	91~100	11250
		101~110	13125
		111~120	15000
		121~130	16875
		131~140	18750
		141~150	20625
		151~160	22500
		161~170	24375
		171~180	26250
		181~220	27500

- $t_{\square a}$  is the acceleration time, but the calculation methods of a ① trapezoid pattern and a ② triangle pattern are different.

The difference between a trapezoid pattern and a triangle pattern can be determined by whether the arrival speed of operation of the traverse distance at the set speed is larger or smaller than the set speed.

Arrival speed ( $V_{max}$ ) =  $\sqrt{\text{traverse distance (m)} \times \text{set acceleration (m/s}^2\text{)}}$

Set speed < arrival speed → ① trapezoid pattern

Set speed > arrival speed → ② triangle pattern

- ① In the case of a trapezoid pattern

$t_{\square a} = V_s/a$   $V_s$ : Set speed (m/s)  $a$ : Directive acceleration (m/s<sup>2</sup>)

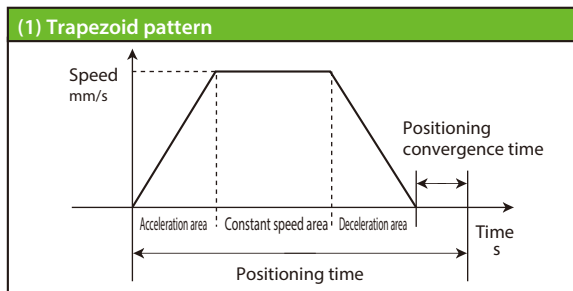

- ② In the case of a triangle pattern

$t_{\square a} = V_t/a$   $V_t$ : Arrival speed (m/s)  $a$ : Directive acceleration (m/s<sup>2</sup>)

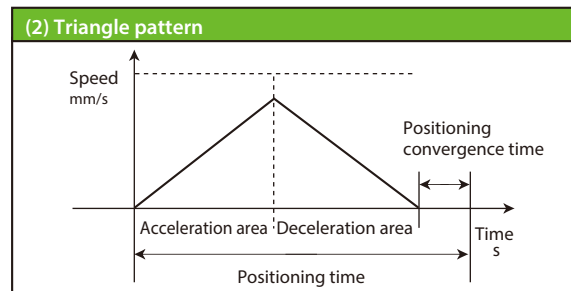

- $t_{\square f}$  is the constant traverse speed. Please calculate this to calculate the constant traverse distance.

$t_{\square f} = L_c/V$   $L_c$ : Constant traverse distance (m)  $V$ : Directive speed (m/s)

\* Constant traverse distance = traverse distance - acceleration distance - deceleration distance  
Acceleration distance (deceleration distance) =  $V^2/2a$

- $t_{\square d}$  is the deceleration time, but if acceleration and deceleration are the same, then it is the same as the acceleration time.

$t_{\square d} = V/a$   $V$ : The set speed (trapezoid pattern) or arrival speed (triangle pattern) (m/s)  $a$ : Directive deceleration (m/s<sup>2</sup>)

[RCS3-RA15R/RA20R only]

- Calculate the average speed. The average speed can be found with the following equation.

$$v_t = \frac{0.5 \cdot v_1 \cdot t_{1a} + v_1 \cdot t_{1f} + 0.5 \cdot v_1 \cdot t_{1d} + 0.5 \cdot v_2 \cdot t_{2a} + v_2 \cdot t_{2f} + 0.5 \cdot v_2 \cdot t_{2d}}{t}$$

$v_1$ : Constant speed when approaching

$v_2$ : Constant speed when returning (trapezoid pattern)

Arrival speed (triangle pattern)

Next, calculate the final continuous operational thrust from the calculated continuous operational thrust  $F_t$  and average speed  $v_t$ .

$$F = F_t + v_t \cdot K$$

Select coefficient  $K$  from the table below.

Model	Coefficient $K$
RA15R	150
RA20R	412.5

Confirm that the calculated continuous operational thrust  $F_t$  ( $F$  calculated by the above formula for RA15R and 20R) is smaller than the allowable continuous operational thrust. The allowable continuous operational thrust force of this product is as follows.

Model	Allowable continuous operational thrust force [N]
RA6R-LCT	420
RA7R-LCT	600
RA8R-LCT	1000
RA10R-LCT	2100
RA13R-LCT/LCN(*2)	Lead 2.5 5100
	Lead 1.25 10200
RA15R-LCT	13500
RA20R-LCT	22500

\*2 For RA13R, please limit the duty cycle to 50% or less.

If the conditions cannot be satisfied, please adopt measures such as shortening the push time or extending the wait time.

# Operating Conditions

RCS3/RCS2 Series Rod type (without load cell)

RCS2

RA13R Servo press compatible The same conditions as the rod type with load cell. Please refer to P.27~30.

RCS3

When using the actuator, the following two conditions must be satisfied.

- Condition 1. The push time must be **the determined time or less**
- Condition 2. The operating duty must not exceed the allowable duty according to the operating conditions (payload and speed)
- Condition 3. In a single cycle, push-motion operation must occur only once

Selection method

Condition 1. Push time

The maximum push time of each push command value is determined in the tables below. When using the actuator, please make sure that the push time is the time indicated in the tables below or less. Please be aware that using the actuator beyond the time indicated in the tables below may cause the actuator to malfunction.

RA15R

Push Command Value (%)	Maximum Push Time (s)
90 or less	Continuous pushing available
91~100	300
110	118
120	58
130	40
140	30
150	25
160	20
170	16
180	13
190	10
200	9

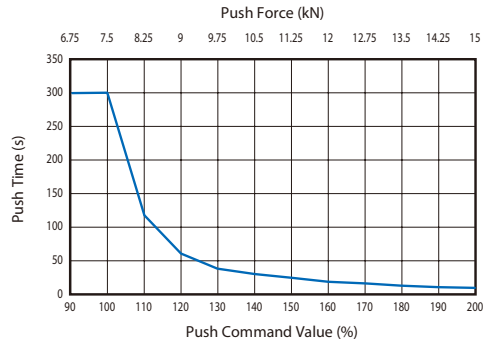

RA20R

Push Command Value (%)	Maximum Push Time (s)
90 or less	Continuous pushing available
91~100	300
110	80
120	50
130	36
140	28
150	22
160	18
170	15
180	13
190	11
200	10

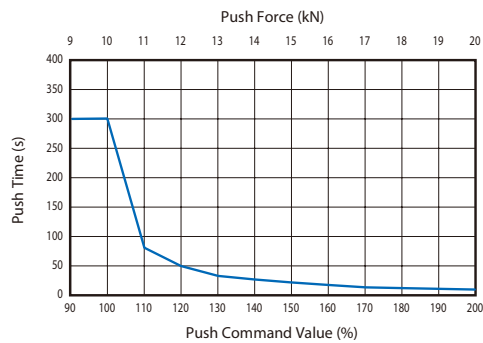



**Condition 2. Duty**

Duty cycle is the percentage of the actuator's active operation time in each cycle. The duty cycle varies depending on the operation conditions (payload and speed). According to the combination of the maximum speed and payload within one cycle, check the guidelines for the allowable duty cycle with the graph below and operate at or below the allowable value.

**<Example>**

If the speed and payload change during reciprocating motion, check using the larger value.

	Forward	Return
Speed	Low	High
Payload	High	Low

Using this combination of values, check with the following graph.

**[Duty Cycle]**

Duty cycle is the percentage of the actuator's active operation time in each cycle.

$$D = \frac{T_M}{T_M + T_R} \times 100(\%)$$

D: Duty  
 T<sub>M</sub>: Operating time (including push-motion operation)  
 T<sub>R</sub>: Stopping time

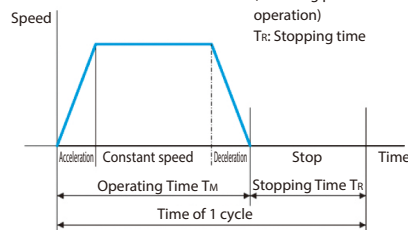

**RCS3**

**RA15R**

**[Vertical mount]**

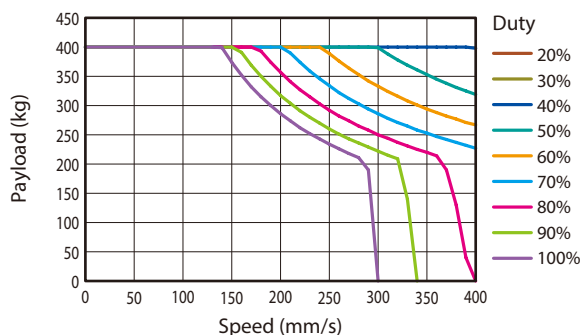

**[Horizontal mount]**

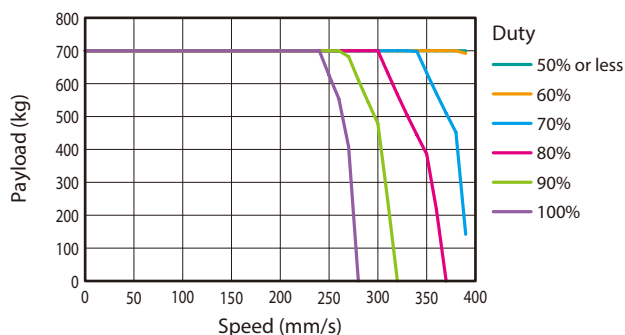

\* The above graph is the case with two external regenerative resistors installed. The number of regenerative resistance units (RESU-35T) can be reduced according to the payload, speed and duty. Contact our sales personnel for details.

**RA20R**

**[Vertical mount]**

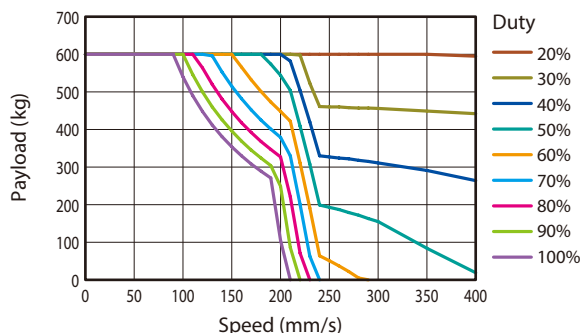

**[Horizontal mount]**

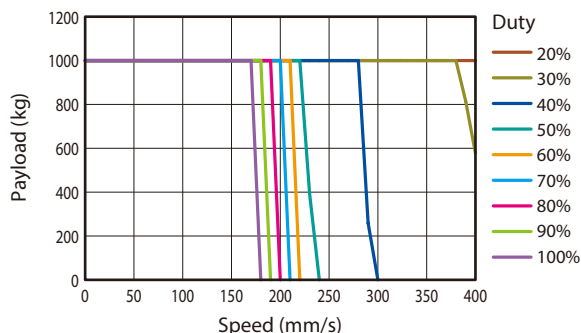

\* The above graph is the case with two external regenerative resistors installed. The number of regenerative resistance units (RESU-35T) can be reduced according to the payload, speed and duty. Contact our sales personnel for details.

# Moment Selection Guide

RCS3/RCS2 Series Rod type (without load cell)

**RCS2**

**RA13R**

Loads can be applied to the rod within the range of the conditions determined by the following formula.

Loads can be applied to the rod of RCS2-RA13R (without load cell) within the range of the conditions determined by the following formula.

$$M+T \leq 120(N\cdot m)$$

$$\text{Load moment } M = Wg \times L_2$$

$$\text{Load torque } T = Wg \times L_1$$

- \* g = Gravitational acceleration 9.8
- \* L1 = Distance from the rod center to the center of gravity of the workpiece
- \* L2 = Distance from the actuator mounting surface to the center of gravity of the workpiece + 0.07

If the above conditions are not satisfied, use an external guide, etc., to make sure that no load is applied to the rod.

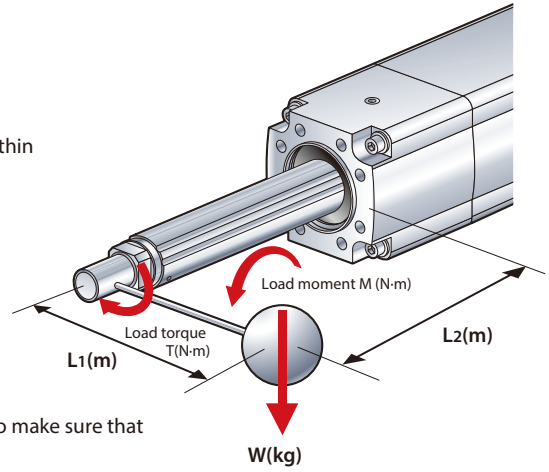

**RCS3**

RCS3-RA15R/RA20R: Loads can be applied to the rod within the range of the following two conditions.

**Condition 1.** The radial load acting must not exceed the maximum allowable radial load

**Condition 2.** The applied moment must satisfy the following formula

$$M \geq Ma + Mb + K \cdot Mc$$

- M: Allowable moment (see table below)
- Ma, Mb, Mc: Load moment (see figure at right)
- K: Uniform coefficient
- RCS3-RA15R: 0.36
- RCS3-RA20R: 0.37

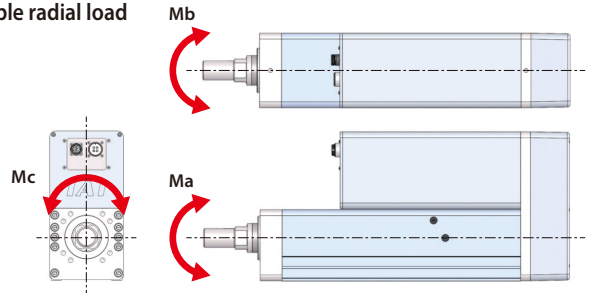

■ **RCS3-RA15R**

Stroke (mm)	100	200	300	400	500
Maximum allowable radial load (N)	392				
Allowable moment (Nm)	140	135	130	125	120

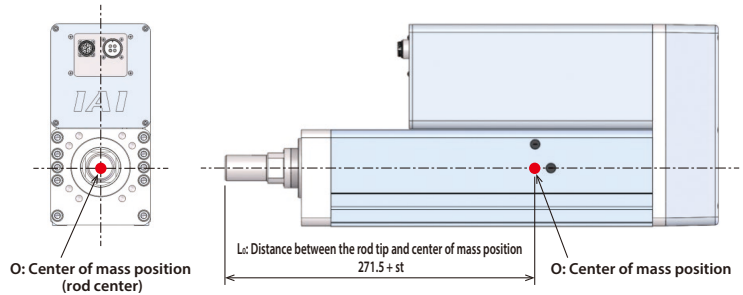

■ **RCS3-RA20R**

Stroke (mm)	100	200	300	400	500
Maximum allowable radial load (N)	540				
Allowable moment (Nm)	230	220	210	200	190

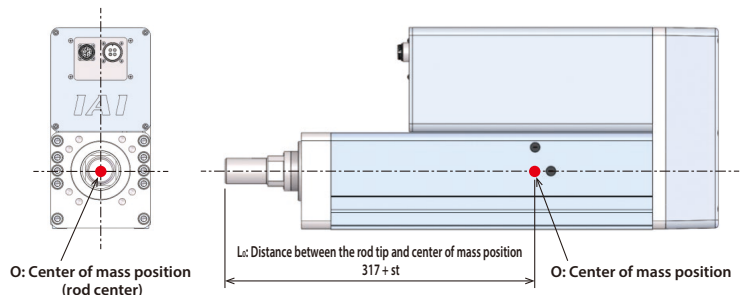

# Mounting Orientation of the Actuator

Some mounting orientations cannot be used or require caution depending on the actuator model. Check the mounting orientation for each model in the table below.

○: Can be mounted x: Cannot be mounted

Classification	Series	Type	Horizontal mounting on flat surface	Vertical mounting	Side mounting	Ceiling mounting
Servo press specification	RCS3	RA4	○	○	○	x
		RA6				
		RA7				
		RA8				
		RA10				
	RCS2	RA15	○	○	x	x
		RA20	○	○	○	○
Rod type (without load cell)	RCS3	RA15	○	○	○	○
		RA20				
	RCS2	RA13				

## Notes When Installing

When installing the front bracket or flange (optional), please be careful that no external force acts on the actuator. (External force may cause malfunctions or damage to parts.)

Please install a support block when front mounting or back mounting a horizontally mounted actuator that is 150st or more. However, adding a support block even for less than 150st is recommended, since vibration might occur depending on the operational and installation conditions and damage the actuator.

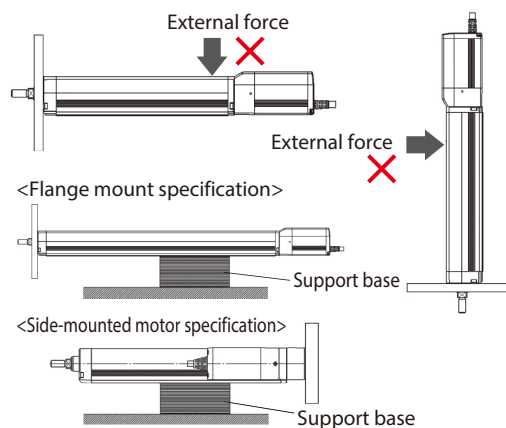

## Options

### Brake

**Model** **B/BN** (without brake box)

**Description** When the actuator is mounted vertically, this works as a holding mechanism that prevents the slider from falling and damaging any attachments when the power or servo is turned off.

### CE Compliant

**Model** **CE**

**Description** If CE is required and the selected model is not CE compliant, please specify this option. For detail, please contact IAI.

### Cable Exit Direction

**Model** **CJT / CJR / CJL / CJB / CJO**

**Description** This option allows you to change the exit direction of the motor-encoder cable to top, bottom, left, or right.

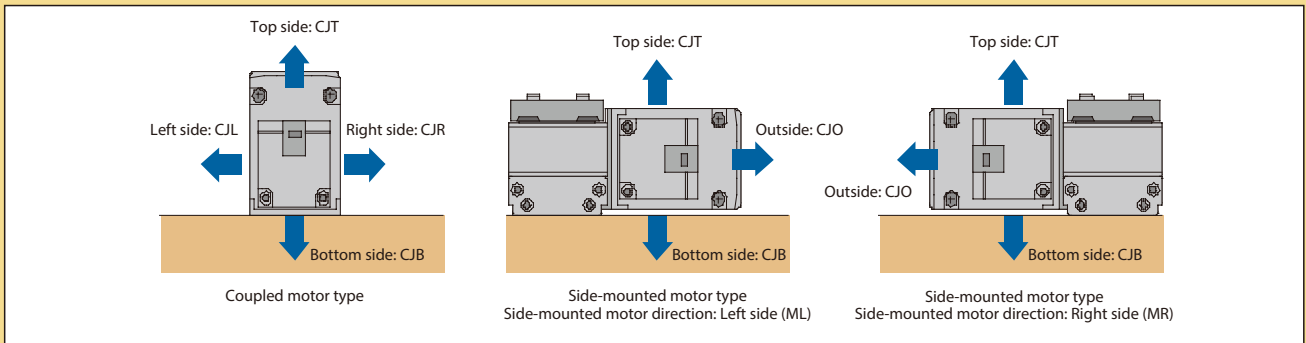

### Flange (Front)

**Model** **FL**

**Description** A bracket that attaches to the actuator body with bolts.

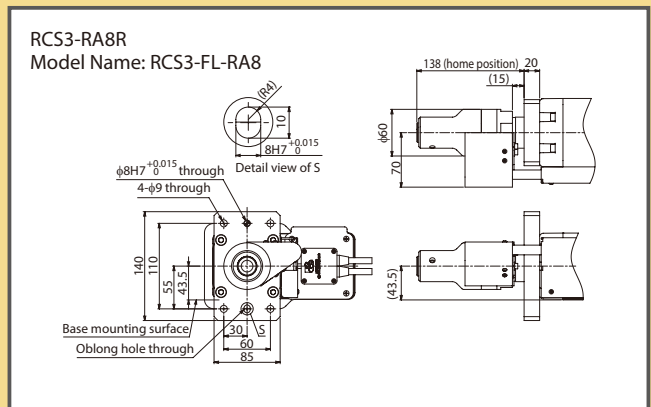
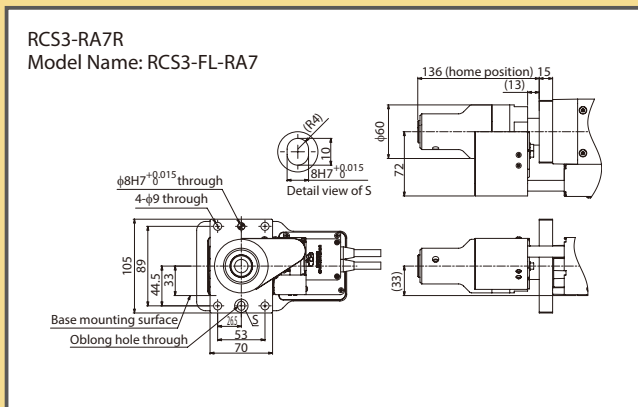
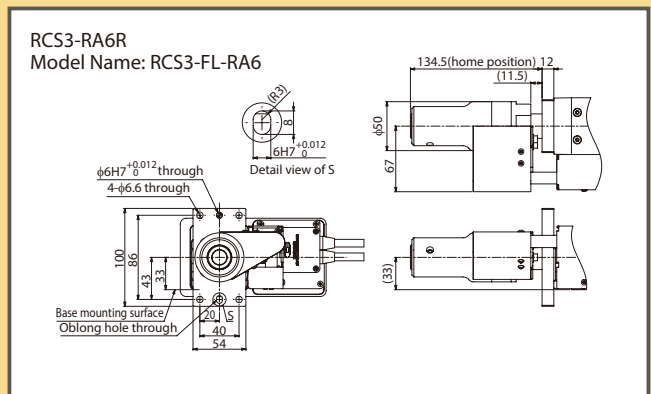
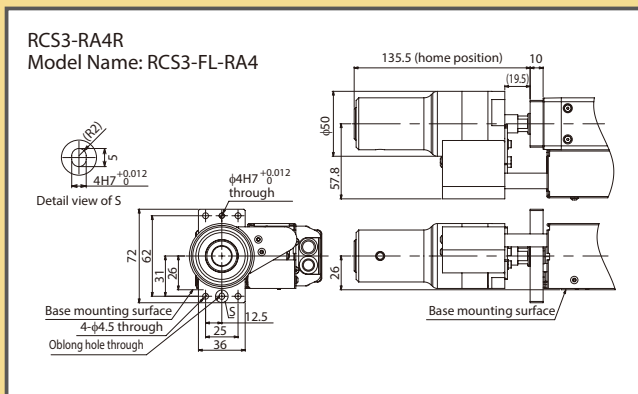

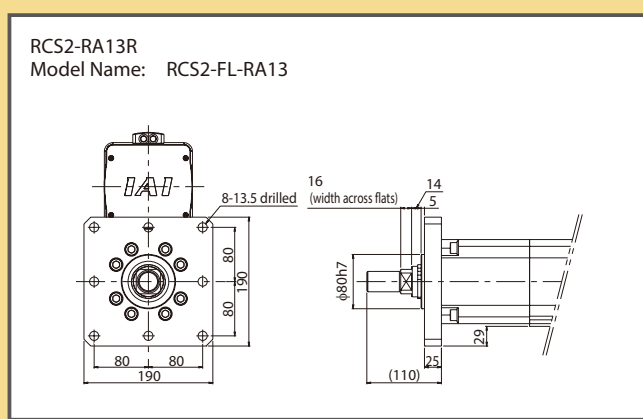
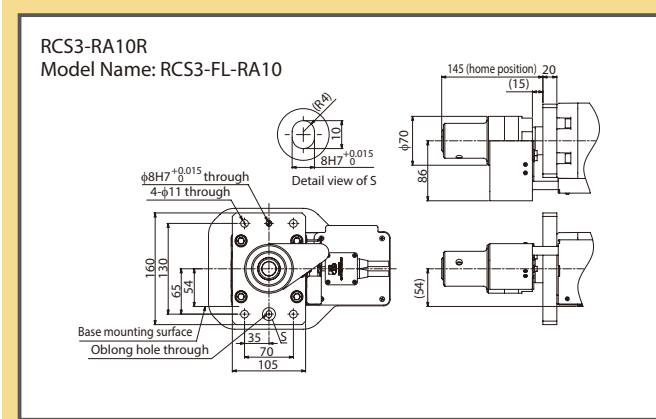

Foot Bracket

Model FT

Description This is a bracket used to fix the actuator with bolts from the top side. (Bolts are tightened from the top, not from the bottom)  
 The actuator body may be twisted or deformed if insufficient number of mounting foot brackets are used. Actuator life could also be shortened.

\* Refer to the installation dimensions in the actuator drawing for the installation pitch between the foot brackets.

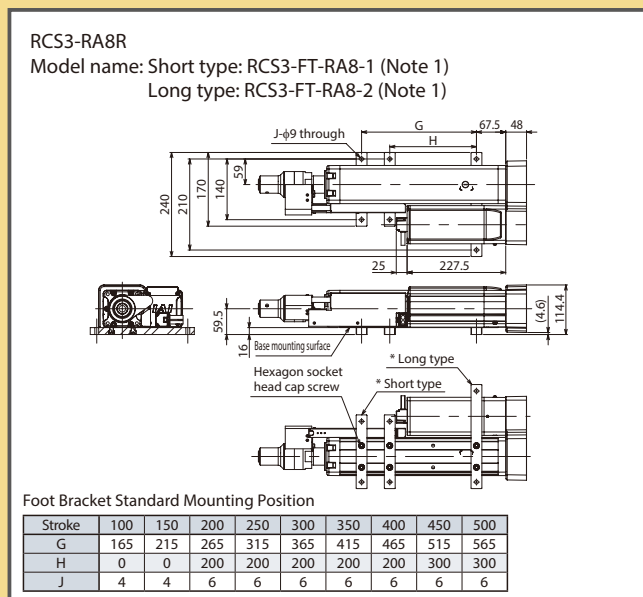
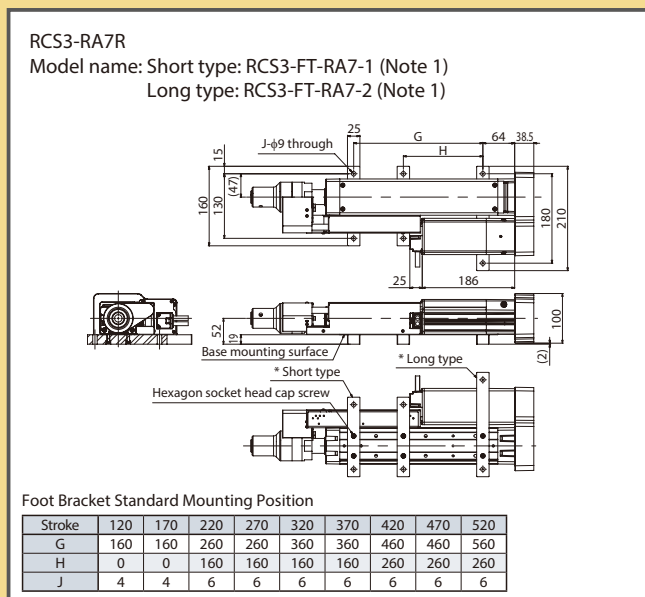
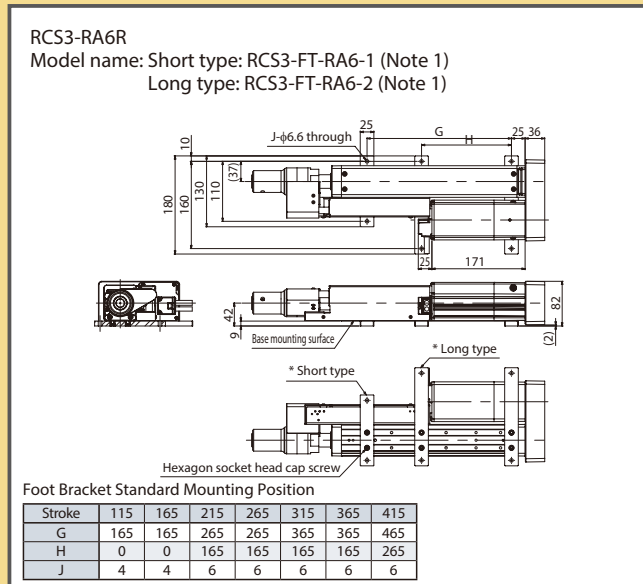
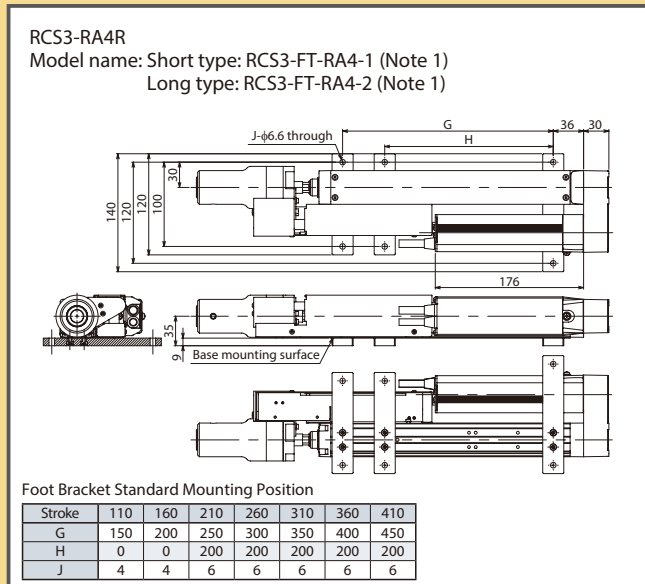

(Note 1) 2 hexagonal socket head bolts enclosed

## RCS3-RA10R

Model name: Short type: RCS3-FT-RA10-1 (Note 1)  
Long type: RCS3-FT-RA10-2 (Note 1)

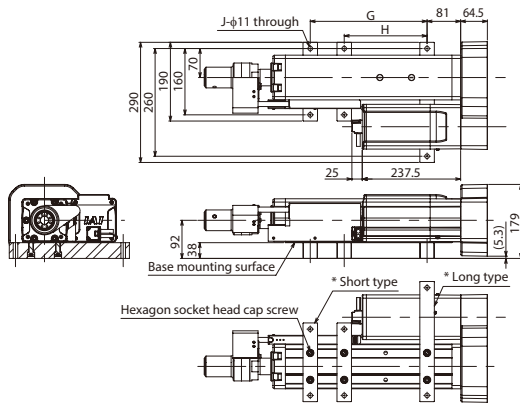

Foot Bracket Standard Mounting Position

Stroke	100	150	200	250	300	350	400	450	500
G	182	232	282	332	382	432	482	532	582
H	0	0	200	200	200	200	200	300	300
J	4	4	6	6	6	6	6	6	6

(Note 1) 2 hexagonal socket head bolts enclosed

## RCS2-RA13R

Model Name: RCS2-FT-RA13

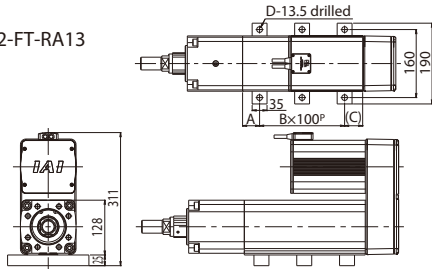

Stroke	50	100	150	200
A	40	65	40	65
B	2	2	3	3
C	42.5	67.5	42.5	67.5
D	6	6	8	8

### Quantities Enclosed

The following number of foot brackets and bolts is enclosed when the foot bracket option (Model: FT) is selected at the time of the actuator purchase.

Model	Stroke (mm)	Foot Bracket	Quantities Enclosed	Number of Bolts Enclosed
RCS3-RA4R	110	Long type	2	4
		Short type	1	4
	160	Long type	1	4
		Short type	2	6
RCS3-RA6R	115~165	Long type	2	4
		Short type	1	6
	215~415	Long type	2	6
		Short type	1	4
RCS3-RA7R	120~170	Long type	1	4
		Short type	2	6
	220~520	Long type	1	6
		Short type	2	6
RCS3-RA8R	100	Long type	2	4
		Short type	1	4
	150	Long type	1	4
		Short type	2	6
RCS3-RA10R	100	Long type	2	4
		Short type	1	4
	150	Long type	1	4
		Short type	2	6
RCS2-RA13R	50~100	-	3	6
		-	4	8
	150~200	-	3	6
		-	4	8

### With Load Cell

#### Model LCT / LCN

**Description** This is an option for installing a load cell on the rod tip of RCS3 Series and RCS2-RA13R (ultra-high thrust actuator) for servo press, and operating with force control. When using as a servo press, be sure to specify. LCT is equipped with a cable track for load cell wiring, while the LCN specification has no cable track and is to be wired by the customer. (LCN is dedicated for RCS2-RA13R.)



#### Caution

When operating RCS2-RA13R with force control, only the SCON-CB controller can be used.

### Side-mounted Motor Direction

#### Model ML / MR / MT

**Description** This allows you to specify the direction of the side-mounted motor type. As viewed from the motor side of the actuator, side-mounting to left is ML, right is MR, and top is MT.

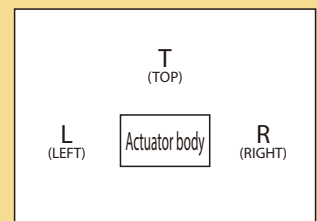

**Side-mounted Motor Direction / Cable Exit Position**

**Model** MT□ / MR□ / ML□

**Description** The combination of side-mounted motor direction and cable exit direction can be specified.

**Notes**  
Be sure to select a symbol in the model number for the side-mounted motor direction and cable exit position.

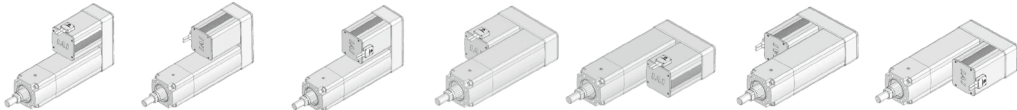

Option Code	MT1	MT2	MT3	MR1	ML1	MR2	ML3
Side-mounted motor direction	Top (standard)	Top	Top	Right side	Left side	Right side	Left side
Cable Exit Position	Top (standard)	Right side	Left side	Top	Top	Right side	Left side

# Note

\*If a Load Cell Calibration Certificate is required by the load cell vendor, there is an extra charge and it must be ordered on the same PO as the actuator. Ordering the certificate after purchasing the actuator will require sending the load cell back to Japan.

# Controller Reference Page List

Please see the catalogs below for more details on the applicable controllers.

	Model name		Controller	Reference catalog
Servo press specification (with load cell)	RCS3	RA4R	SCON-CB/CGB <Servo press specification>	Please contact IAI America for details.
		RA6R		
		RA7R		
		RA8R		
		RA10R		
		RA15R		
		RA20R		
	RCS2	RA13R		

Rod (Position) type (without load cell)	RCS3	RA15R	SCON-CGB	This catalog	P. 40
		RA20R			
	RCS2	RA13R	SCON-CB/CGB	Please contact IAI America for details.	
			SCON-LC/LCG		
			SSEL-CS		
			XSEL-P/Q/RA/SA		



# SCON-CGB

Position Controller for RCS3-RA15R/RA20R without Load Cell



## Features

### 1 Supports battery-less absolute encoder

The RCS3 can operate equipped with a battery-less absolute encoder. Since no battery is needed for retaining position data, it is possible to save space around the control panel, which helps to keep down the initial cost and maintenance cost.



### 2 Compatible with major field networks <Optional function>

Can be directly connected to DeviceNet, CC-Link, and PROFIBUS-DP, as well as MECHATROLINK, CompoNet, EtherCAT, EtherNet/IP and PROFINET IO. It can also be operated by specifying the coordinate values directly via the field network.

DeviceNet

PROFI  
BUS

CompoNet

CC-Link

EtherNet/IP

EtherCAT

MECHATROLINK

PROFI  
NET

### 3 Vibration suppression control function <Standard function>

Equipped with a damping control function that reduces the shaking (vibration) of the workpiece attached to the slider of the actuator. The standby time for vibration to settle is shortened, making it possible to shorten the cycle time.

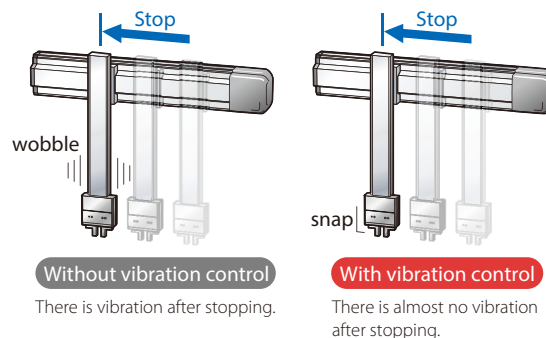

### 4 Predictive maintenance function <Standard function>

- A function that issues a warning when a motor overload is detected has been included. Monitoring changes in the temperature of the motor makes it possible to detect abnormalities before the occurrence of a breakdown or a malfunction.
- Monitoring functions have been improved. Similar to an oscilloscope, it is now possible to acquire the waveforms of the position, speed, etc. from the instant the state of the selected signal changes. It is also possible to acquire the signal states of positioning complete, alarms, etc.
- A function that integrates the number of cycles with the traveled distance accumulation makes it possible to check maintenance timing.
- The calendar function makes it possible to keep a timetable of the alarms that have been generated.



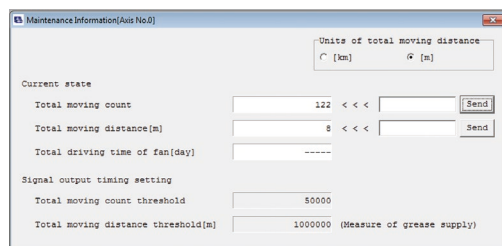







<Maintenance information>



<Calendar function>

		Time (Y/M/D h:m:s)
0E5	Encoder data receive error	000C 17/02/02 04:50:27
04F	Total moving distance is exceeded threshold.	---- 17/02/02 04:49:32
04E	Total moving count is exceeded threshold.	---- 17/02/02 04:49:32
0E5	Encoder data receive error	000C 17/02/02 04:49:32
0E5	Encoder data receive error	000C 17/02/02 04:33:04
FFF	PowerUP No Error	---- 17/02/02 04:33:04

## List of Models

Model Number		SCON-CGB									
External view											
I/O Type	Standard specification	Field network type (*1)									
	PIO connection specification (*1)	 DeviceNet connection specification	 CC-Link connection specification	 PROFIBUS-DP connection specification	 CompoNet connection specification	 MECHATROLINK I, II connection specification	 MECHATROLINK III connection specification	 EtherCAT connection specification	 EtherNet/IP connection specification	 PROFINET IO connection specification	
I/O type model number	NP/PN	DV	CC	PR	CN	ML	ML3	EC	EP	PRT	
Supported encoder		Battery-less Absolute									
SCON-CGB	3000W	○									
	3300W	○	○	○	○	○	○	○	○	○	

(\*1) Please note that the field networks cannot be communicated with using the PIO.

## Model

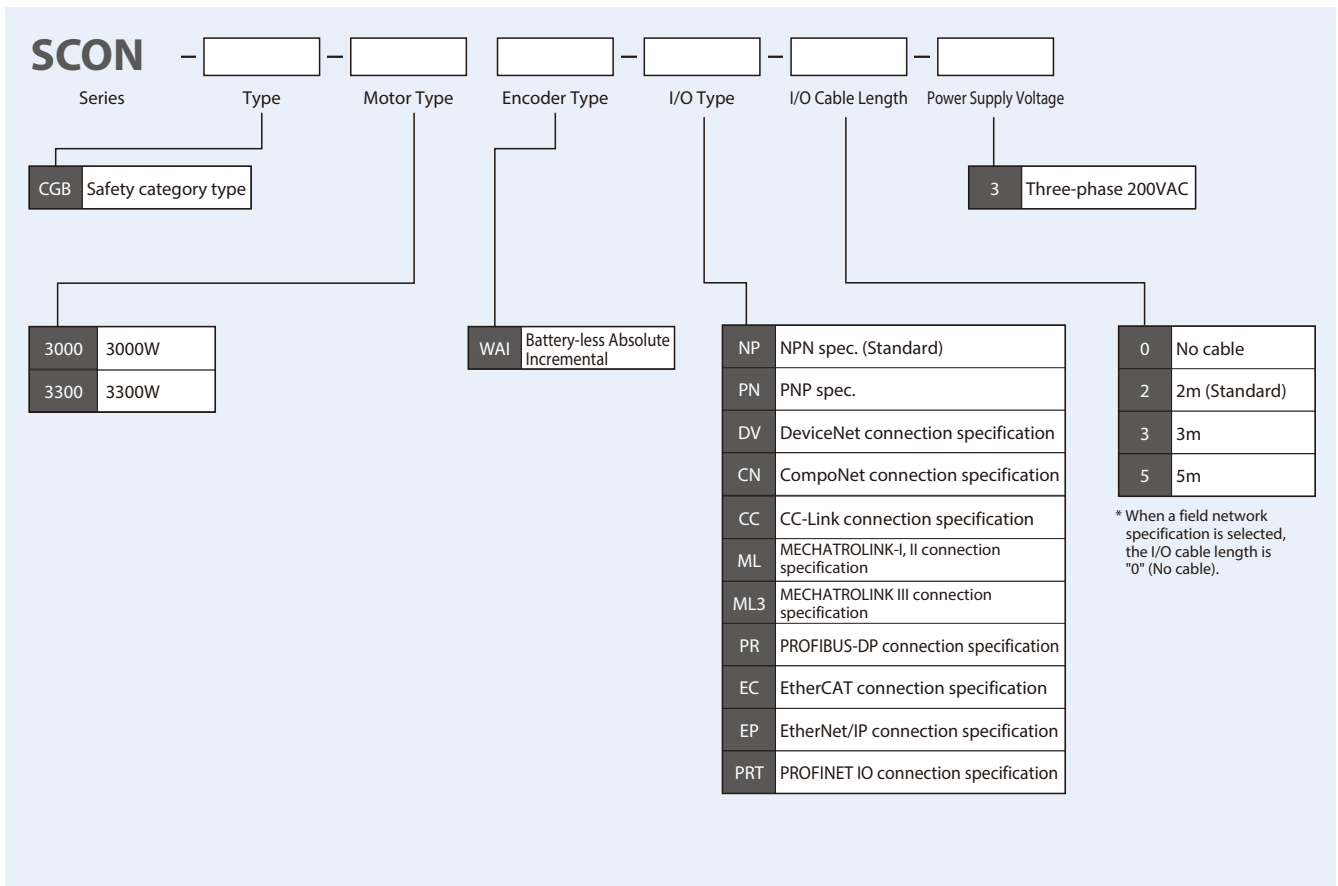

System Configuration

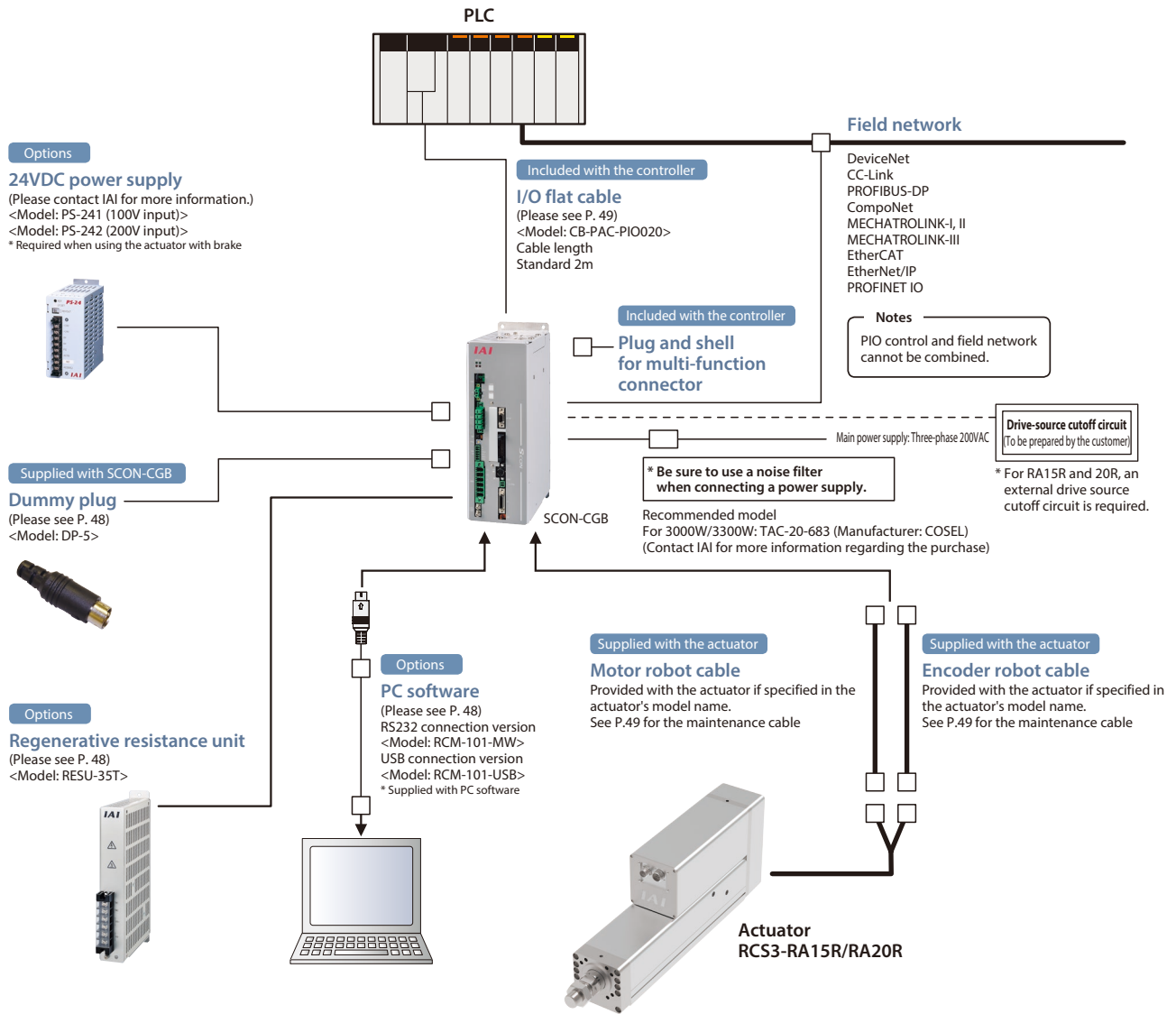

RCS3-RA15R/20R (with brake) wiring

The brake circuit of RCS3-RA15R/20R is built into the actuator. Input a 24VDC  $\pm 10\%$  voltage to the actuator. (If the input voltage is low, the brake cannot be released. Be sure to use a power supply with the voltage drop in wiring taken into account.) 24VDC must be supplied to both the actuator and controller.

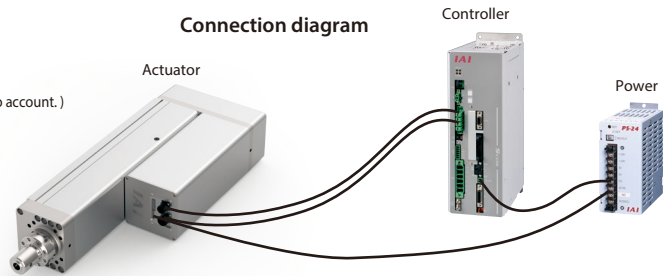

The cable is to be prepared by the user. The connector is included.  
 \* For details, please refer to the instruction manual.

Pulse Converter: Model JM-08

Converts differential pulses to the open-collector specification (NPN only). Please use this converter if the host controller uses open-collector specification for pulse input.

Specifications

Item	Specification
Input power	24VDC $\pm 10\%$ (Max. 50mA)
Input pulse	Differential input (Max. 10mA) (RS422 compliant)
Input frequency	500kHz or less
Output pulse	24VDC open collector (collector current Max. 25mA)
Mass	10g or less (not including the cable connectors)
Accessories	37104-3122-000FL manufactured by 3M (e-CON connector) x 2 Applicable wire AWG No.24~26

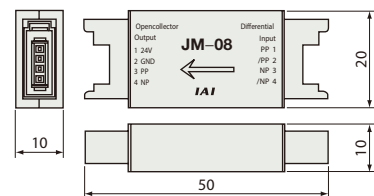

## Operation Mode

In the positioner mode, the unit can be operated with the position data (travel position, speed, acceleration, etc.) input to the controller from an external source using I/O (input/output signal). In this mode, six operation modes can be selected according to the parameters.

Mode	Type	Number of positioning points	Features	
Positioner mode	Positioning mode	PIO Pattern 0	64 points	This is the factory default standard mode. The number of the target position is externally specified.
	Teaching mode	PIO Pattern 1	64 points	In this mode, the slider (rod) is moved with an external signal and its stop position can be registered as position data.
	256-point mode	PIO Pattern 2	256 points	This is a mode which increases the number of points in the positioning mode to 256.
	512-point mode	PIO Pattern 3	512 points	This is a mode which increases the number of points in the positioning mode to 512.
	Solenoid valve mode 1	PIO Pattern 4	7 points	In this mode, travel is possible by using just the ON/OFF signal, similar to the solenoid valve of the air cylinder.
	Solenoid valve mode 2	PIO Pattern 5	3 points	In this solenoid valve mode, the output signal is the same as the auto switch for air cylinders.

## I/O Signal Table \* The I/O signal assignment can be selected from 6 types.

Pin No.	Category	Number of positioning points	Parameter (PIO pattern) selection					
			0	1	2	3	4	5
			Positioning mode	Teaching mode	256-point mode	512-point mode	Solenoid valve mode 1	Solenoid valve mode 2
			64 points	64 points	256 points	512 points	7 points	3 points
1A	24V							P24
2A	24V							P24
3A	—							NC
4A	—							NC
5A	Input	IN0	PC1	PC1	PC1	PC1	ST0	ST0
6A		IN1	PC2	PC2	PC2	PC2	ST1	ST1(JOG+)
7A		IN2	PC4	PC4	PC4	PC4	ST2	ST2(-)
8A		IN3	PC8	PC8	PC8	PC8	ST3	—
9A		IN4	PC16	PC16	PC16	PC16	ST4	—
10A		IN5	PC32	PC32	PC32	PC32	ST5	—
11A		IN6	—	MODE	PC64	PC64	ST6	—
12A		IN7	—	JISL	PC128	PC128	—	—
13A		IN8	—	JOG+	—	PC256	—	—
14A		IN9	BKRL	JOG-	BKRL	BKRL	BKRL	BKRL
15A		IN10	RMOD	RMOD	RMOD	RMOD	RMOD	RMOD
16A		IN11	HOME	HOME	HOME	HOME	HOME	—
17A		IN12	*STP	*STP	*STP	*STP	*STP	—
18A		IN13	CSTR	CSTR/PWRT	CSTR	CSTR	—	—
19A		IN14	RES	RES	RES	RES	RES	RES
20A		IN15	SON	SON	SON	SON	SON	SON
1B	Output	OUT0	PM1	PM1	PM1	PM1	PE0	LSO
2B		OUT1	PM2	PM2	PM2	PM2	PE1	LS1(TRQS)
3B		OUT2	PM4	PM4	PM4	PM4	PE2	LS2(-)
4B		OUT3	PM8	PM8	PM8	PM8	PE3	—
5B		OUT4	PM16	PM16	PM16	PM16	PE4	—
6B		OUT5	PM32	PM32	PM32	PM32	PE5	—
7B		OUT6	MOVE	MOVE	PM64	PM64	PE6	—
8B		OUT7	ZONE1	MODES	PM128	PM128	ZONE1	ZONE1
9B		OUT8	PZONE/ZONE2	PZONE/ZONE1	PZONE/ZONE1	PM256	PZONE/ZONE2	PZONE/ZONE2
10B		OUT9	RMDS	RMDS	RMDS	RMDS	RMDS	RMDS
11B		OUT10	HEND	HEND	HEND	HEND	HEND	HEND
12B		OUT11	PEND	PEND/WEND	PEND	PEND	PEND	—
13B		OUT12	SV	SV	SV	SV	SV	SV
14B		OUT13	*EMGS	*EMGS	*EMGS	*EMGS	*EMGS	*EMGS
15B		OUT14	*ALM	*ALM	*ALM	*ALM	*ALM	*ALM
16B	OUT15	*BALM	*BALM	*BALM	*BALM	*BALM	*BALM	
17B	—						—	
18B	—						—	
19B	0V						N	
20B	0V						N	

Signal codes accompanied by an asterisk \* indicate a reverse logic signal.

Field Network Specification: Explanation of Operation Modes

If controlling via a field network, you can select one of the following nine modes to operate the actuator. Please note that the data areas required on the PLC side will vary depending on the mode.

Mode Description

Mode	Description
0 Remote I/O mode	Similar to the PIO specification, this mode operates by directing bytes the ON/OFF signal via a network. The number of positioning points and functions will vary depending on the operation patterns (PIO patterns) set by the controller's parameters.
1 Position/simple direct value mode	The target position value is directly input, while all other operational conditions (speed, acceleration, etc.) are set by indicating the position number corresponding to the desired operating conditions from the position data table.
2 Half direct value mode	The actuator is operated by directly inputting values for speed, acceleration/deceleration rate and push current, as well as the target position.
3 Full direct value mode	The actuator is operated by directly inputting values for the target position, speed, acceleration/deceleration rate and push current limit value, etc. In addition, you are able to read the current position, current speed, and the command current value, etc.
4 Remote I/O mode 2	This mode is the same as the remote I/O mode above, with the added functionality of reading current position and the command current value.
5 Position/simple direct value mode 2	This mode is equipped with force control function instead of the teaching and zone functions of the position/simple direct value mode described above.
6 Half direct value mode 2	This mode is able to read the load cell data instead of reading the command current, a function of the half direct value mode above, and also supports the force control function.
7 Remote I/O mode 3	This mode is the same as the remote I/O mode above, with the added functionality of reading current position and load cell data.
8 Half direct value mode 3	This mode supports the vibration control function instead of the jog function of the half direct value mode described above.

Required Data Size for Each Network

Mode	DeviceNet	CompoNet	CC-Link	MECHATROLINK I, II	PROFIBUS-DP	EtherCAT	EtherNet/IP	PROFINET IO
0 Remote I/O mode	2 bytes	2 bytes	1 station	2 bytes	2 bytes	2 bytes	2 bytes	2 bytes
1 Position/simple direct value mode	8 bytes	8 bytes	1 station	8 bytes	8 bytes	8 bytes	8 bytes	8 bytes
2 Half direct value mode	16 bytes	16 bytes	2 stations	16 bytes	16 bytes	16 bytes	16 bytes	16 bytes
3 Full direct value mode	32 bytes	32 bytes	4 stations	x (Note 1)	32 bytes	32 bytes	32 bytes	32 bytes
4 Remote I/O mode 2	12 bytes	12 bytes	1 station	12 bytes	12 bytes	12 bytes	12 bytes	12 bytes
5 Position/simple direct value mode 2	8 bytes	8 bytes	1 station	8 bytes	8 bytes	8 bytes	8 bytes	8 bytes
6 Half direct value mode 2	16 bytes	16 bytes	2 stations	16 bytes	16 bytes	16 bytes	16 bytes	16 bytes
7 Remote I/O mode 3	12 bytes	12 bytes	1 station	12 bytes	12 bytes	12 bytes	12 bytes	12 bytes
8 Half direct value mode 3	16 bytes	16 bytes	2 stations	16 bytes	16 bytes	16 bytes	16 bytes	16 bytes

(Note 1) Please note that the MECHATROLINK specification does not support the full direct value mode.

List of Functions by Operation Mode

	Remote I/O mode	Position/simple direct value mode	Half direct value mode	Full direct value mode (Note 1)	Remote I/O mode 2	Position/simple direct value mode 2	Half direct value mode 2	Remote I/O mode 3	Half direct value mode 3
Number of positioning points	512 points	768 points	Unlimited	Unlimited	512 points	768 points	Unlimited	512 points	Unlimited
Operates by direct assignment of position data	x	o	o	o	x	o	o	x	o
Direct assignment of speed/acceleration	x	x	o	o	x	x	o	x	o
Push-motion operation	o	o	o	o	o	o	o	o	o
Current position read	x	o	o	o	o	o	o	o	o
Current speed read	x	x	o	o	x	x	o	x	o
Position No. specified operation	o	o	x	x	o	o	x	o	x
Completed position No. reading	o	o	x	x	o	o	x	o	x
Vibration control	o	o	x	o	o	o	x	o	o
Servo gain switch	o	o	o	o	o	o	x	o	o

\* o indicates that the operation is supported, and X indicates that it is not supported.

(Note 1) Please note that the MECHATROLINK specification does not support the full direct value mode.

## I/O Wiring Diagram

### Positioning Mode / Teaching Mode / Solenoid Valve Mode

PIO connector (NPN specification)

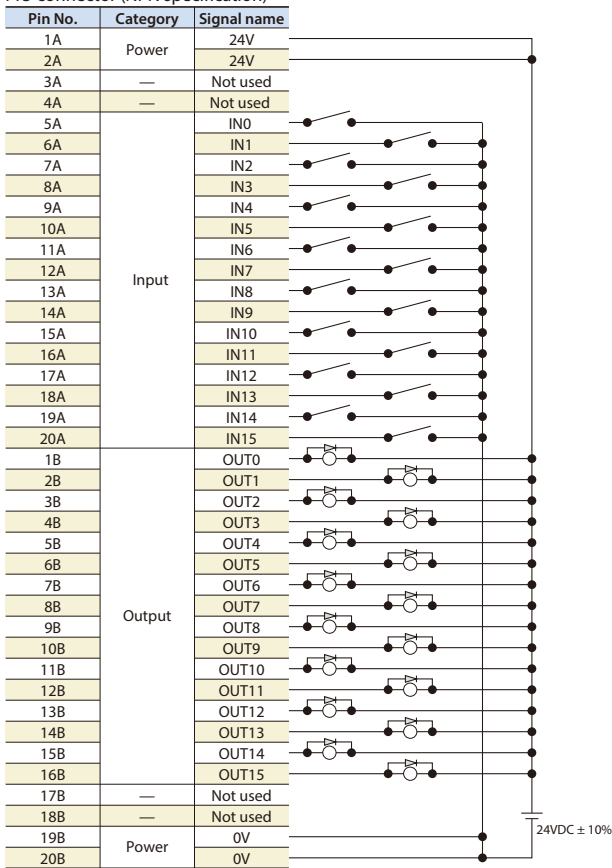

\* Connect pin numbers 1A and 2A to 24V, and connect pin numbers 19B and 20B to 0V.

## PIO Input/Output Interface

### Input External input specification

Item	Specification
Input voltage	24VDC ±10%
Input current	4mA/circuit
ON/OFF voltage	ON voltage: Min. 18.0VDC OFF voltage Max. 6.0VDC
Isolation method	Photocoupler

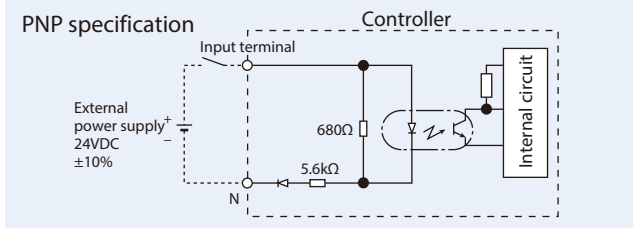
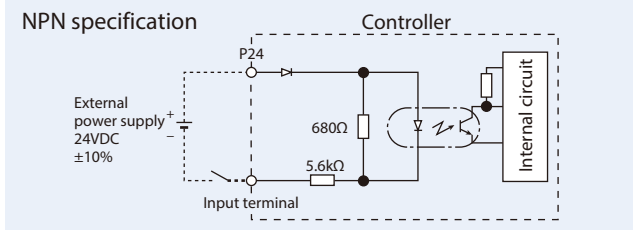

### Output External output specification

Item	Specification
Load voltage	24VDC +/- 10%
Maximum load current	50mA/point
Leakage current	Max. 0.1mA/point
Isolation method	Photocoupler

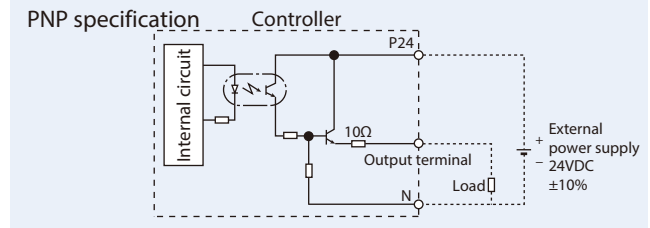
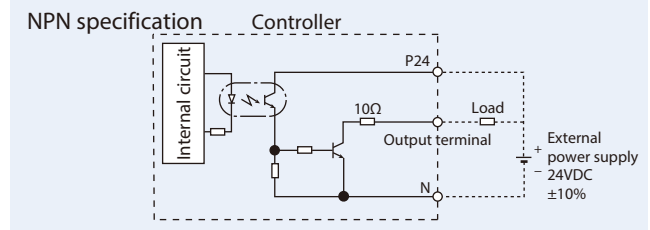

Multi-function Connector (Interface)

(1) When the host controller inputs feedback pulses with a line differential receiver.

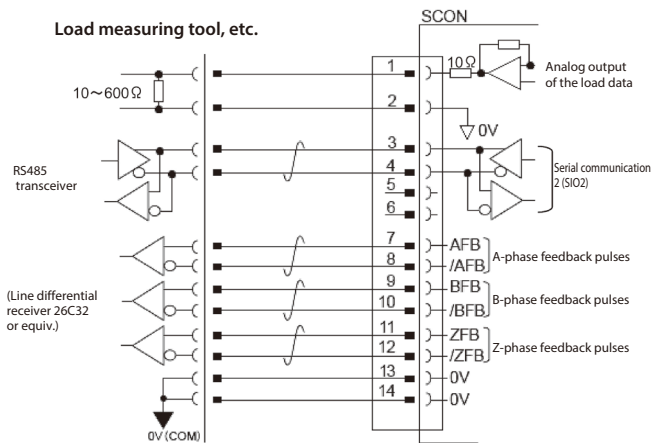

(2) When the host controller inputs feedback pulses with an open collector

Requires a pulse converter (JM-08: optional \*).

\* Please see P.42 for more information

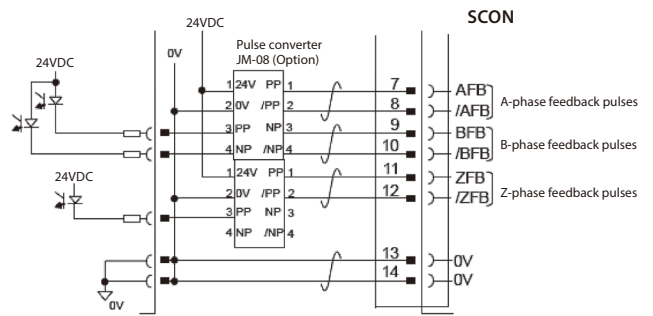

Specifications Table

Item	Specification	
Compatible motor capacity	3000W-3300W	
Connecting actuators	RCS3 Series actuator	
Number of controlled axes	1-axis	
Method of operation	Positioner type	
Backup memory	Non-volatile memory (FRAM)	
I/O connector	40-pin connector	
Number of I/O points	Input 16 points / output 16 points	
I/O power	External supply 24VDC ±10%	
Brake power	External supply 24VDC ±10% (Max. 0.1A) * Max. 1.5 A must be separately supplied for RCS3-RA15R/RA20R as well	
Serial communication	RS485 2ch	
Position detection method	Battery-less absolute encoder	
Drive-source cutoff function	No built-in relay	
Electromagnetic brake force release	External brake release switch ON/OFF	
Input power	Three-phase 200~230VAC ±10%	
Power capacity	3000W/5705VA 3300W/6062VA	
SCON-CB/CGB	External interface	PI/O specification Dedicated 24VDC signal inputs/outputs (NPN/PPN selectable) --- Max. of 16 input/16 output points
		Fieldbus specification DeviceNet, CC-Link, PROFIBUS-DP, CompoNet, MECHATROLINK-I/II, MECHATROLINK-III, EtherCAT, EtherNet/IP, PROFINET IO
		Data retention memory Position data and parameters are saved in non-volatile memory. (Unlimited rewrites)
Vibration resistant	X, Y and Z directions 10~57Hz Single-side width 0.035mm (continuous), 0.075mm (intermittent) 58~150Hz 4.9m/s <sup>2</sup> (continuous), 9.8m/s <sup>2</sup> (intermittent)	
Calendar/clock functionality	Retention time	Approx. 10 days
	Charging time	Approx. 100 hours
Protection functionality	Overcurrent, abnormal temperature, fan speed degradation monitoring, encoder disconnection, etc.	
Internal regenerative resistance value	34Ω 160W	
Ambient operating temperature	0 to 40°C	
Ambient operating humidity	85% or less (Non-condensing)	
Operating ambience	Free from corrosive gases	
Ingress protection	IP20	
Mass	About 2.8kg	
External dimensions	92.7mm(W)×300mm(H)×172mm(D)	

## External Dimensions

### For 3000W/3300W

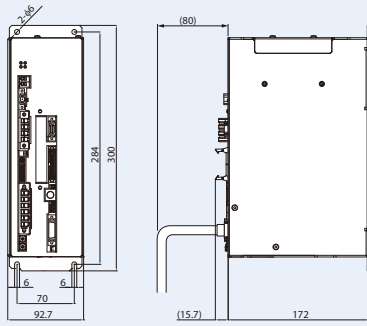

## Name of Each Component

### [For 3000W/3300W]

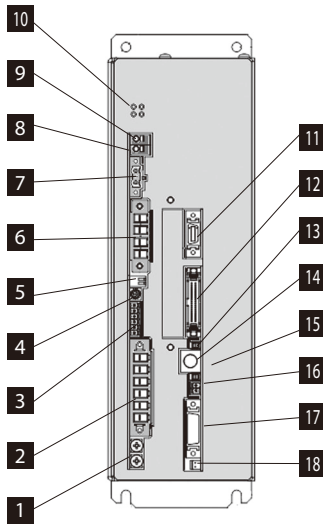

#### 1 FG connection terminal

A terminal for connecting the ground line to prevent electric shock and noise. It is connected to the PE power supply connector inside the controller.

#### 2 Power supply connector (PWR)

A connector used to connect to the AC power supply. Provides power both to the controller and the actuator.

#### 3 System I/O connector (SYS I/O)

A connector used to connect switches such as emergency stop switch.

#### 4 Axis number setting switch (ADRS)

A switch for setting the axis number when operating multiple axes by serial communication. When using the SIO converter, it is possible to control multiple axes without attaching/detaching the connector of the communication cable from teaching tools such as PCs, etc.

#### 5 Piano switch

Not used.

#### 6 Motor connector (MOT)

A connector for the actuator motor cable.

#### 7 Regenerative resistance unit cable connector (RB)

A connector for the external regenerative resistance unit.

#### 8 Charge status display LED

This displays the charge status inside the controller.  
Caution: While this LED is lit, do not touch the controller or regenerative resistance unit in order to prevent electric shock.

#### 9 Internal regenerative resistance effective connector

A short-circuit cable is connected at shipping.  
Caution: Be sure to use with the short circuit cable attached.  
Use without the cable will damage the equipment.

#### 10 LED display (PWR, SV, ALM, EMG)

This represents the operation status of the controller.  
○: ON ×: OFF △: Undefined (ON or OFF)

LED				Operating status
PWR (green)	SV (green)	ALM (orange)	EMG (red)	
×	×	×	×	Control power OFF
○	×	×	×	Controller starts up normally
○	×	×	×	Servo OFF
○	○ (Note 1)	×	×	Servo ON
○	×	○	△	Alarm
○	×	△	○	Emergency stop
○	△	△	△	Warning

Note 1. Blinks when automatic servo is OFF

#### 11 Multi-function connector (MF I/F)

A connector to output the feedback pulses and analog load data of the load cell, and to use the SIO communication function (SIO2).

#### 12 PIO connector (PIO)

A connector for control input/output signal connection. (Note) It is not installed for the fieldbus specification.

#### 13 Operation mode setting switch (MANU/AUTO)

An interlocking switch for preventing duplication of movement commands from PIO (PLC) and commands from teaching tools such as PCs, etc.

#### 14 SIO connector (SIO)

A connector used to connect teaching pendants or communication cables to the PC.

#### 15 Brake release switch (BK RLS / NOM)

A switch to be used to release the brake of the actuator with brake forcibly.  
Warning: Be sure to set this switch to the NOM side in normal operation. If it is left on the RLS side, the brake will not be applied even if the servo is turned OFF. If it is vertically mounted, the workpiece may fall, risking injury or damage to the workpiece.

#### 16 Brake power supply connector (BK PWR)

A connector for supplying power (24VDC) to release the brake when using an actuator with brake.

#### 17 Encoder connector (PG)

A connector for the actuator encoder cable.

#### 18 Connector for the absolute data backup battery

A battery cable connector used for the absolute specification.



Options

### Touch panel teaching pendant

**Features** A teaching device equipped with functions such as position teaching, trial operation, and monitoring.

**Model** **TB-02-□**

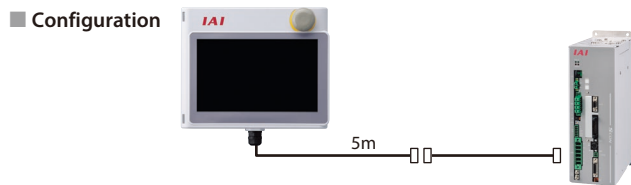

**Specifications**

Rated voltage	24V DC
Power consumption	3.6W or less (150mA or less)
Ambient operating temperature	0 to 40°C
Ambient operating humidity	20~85% RH (Non-condensing)
Environmental resistance	IP20
Mass	470g (TB-02 unit only)

### PC software (Windows only)

**Features** The start-up support software which comes equipped with functions such as position teaching, trial operation, and monitoring. A complete range of functions needed for making adjustments contributes to shortened start-up time.

**Model** **RCM-101-MW** (with an external device communication cable + RS232 conversion unit)

Compatible with Ver. 10.02.01.00 or later

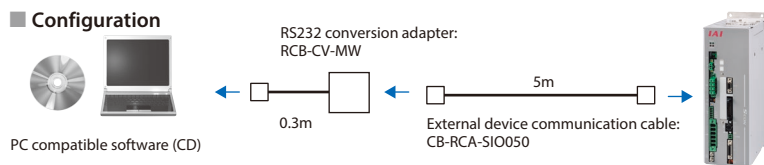

XP SP2 or later / Vista / 7 / 8



**Model** **RCM-101-USB** (with an external device communication cable + USB conversion adapter + USB cable)

Compatible with Ver. 10.02.01.00 or later

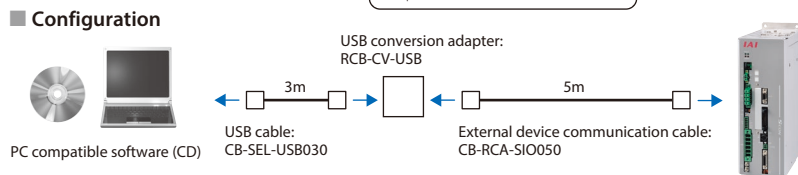

### Regenerative resistance unit

**Features** Unit that converts the regenerative current generated during motor deceleration into heat.

<For 3000W/3300W>

**Model** **RESU-35T**

**Specifications**

Unit weight	About 1.8kg
Built-in regenerative resistance value	30Ω 450W
Unit mounting method	Screw mount

Note: The cable is to be prepared by the user.

**Necessary Amount Guideline**

● 3000W, 3300W

Number of connected units	2
---------------------------	---

\* Please check the allowable conditions in "Operating Conditions" on P.48~48.  
 \* The number of regenerative resistances can be reduced according to the payload, speed and duty. Contact our sales personnel for details.

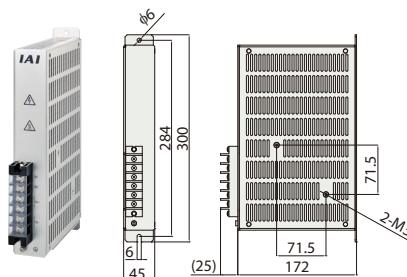

### Dummy plug

**Features** This is required when the safety category specification (SCON-CGB) is used.

**Model** **DP-5**



## Maintenance Parts

When placing an order for a replacement cable, please use the model name shown below.

### ■ Cable Compatibility Chart

Model name		Motor cable	Motor robot cable	Encoder cable	Encoder robot cable
RCS3	RA15R	-	CB-RCS3-MA□□□□-RB	-	CB-RCS3-PLA□□□□-RB
	RA20R				

Model name	PIO flat cable
SCON-CGB	CB-PAC-PIO□□□□

### Model CB-RCS3-MA□□□□-RB

\* Please indicate the cable length (L) in □□□, (e.g. 080=8m) maximum 30m.

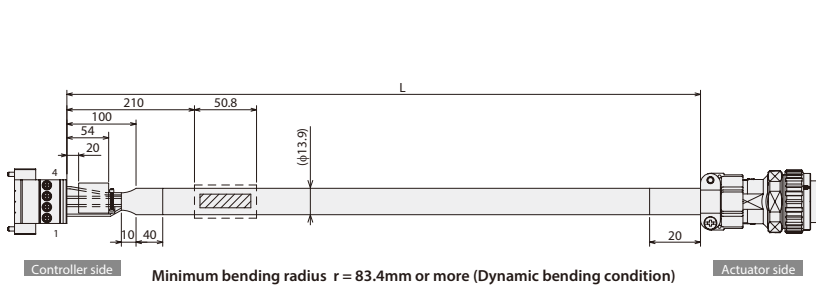

IPC5/4-STF-7.62				JL10-6A18-105E-EB			
Wiring	Color	Signal	No.	No.	Signal	Color	Wiring
Green/Yellow	PE	U	1	A	U	Black 1	AWG12 (Solder)
Black 1	U	V	2	B	V	Black 2	
Black 2	V	W	3	C	W	Black 3	
Black 3	W		4	D	PE	Green/Yellow	

### Model CB-RCS3-PLA□□□□-RB

\* Please indicate the cable length (L) in □□□, (e.g. 080=8m) maximum 30m.

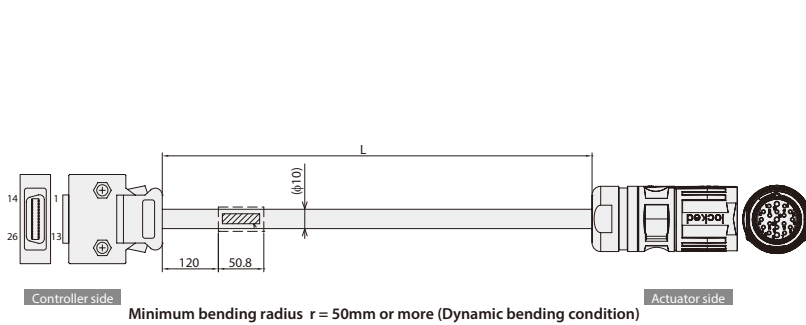

10126-3000PE				CA-1951N1280DNS			
Wiring	Color	Signal	No.	No.	Signal	Color	Wiring
-	-	-	11	1	LS	Brown/Black	AWG26 (Soldered)
White/Orange	E24V	12	12	2	CLEEP	Brown/Black	
White/Green	E24G	13	13	3	OT	Brown/Red	
Brown/Blue	LS	26	26	4	RSV	Brown/Black	
Brown/Yellow	CLEEP	25	25	5	BAT+	Purple	
Brown/Red	OT	24	24	6	VCC	Red	
Brown/Black	RSV	23	23	7	LC SRD+	White/Blue	
White/Blue	LC SRD+	9	9	8	LC SRD-	White/Red	
White/Yellow	LC SRD-	10	10	9	LC VCC	White/Red	
White/Red	LC VCC	18	18	10	BKR+	Yellow	
White/Black	LC GND	19	19	11	BKR-	Blue	
-	-	-	1	12	FG	Drain	
-	-	-	2	13	E24V	White/Orange	
-	-	-	3	14	BAT-	Gray	
-	-	-	4	15	SRD+	Orange	
-	-	-	5	16	SRD-	Green	
-	-	-	6	17	LC GND	White/Black	
Orange	SRD+	7	7	18	E24G	White/Green	
Green	SRD-	8	8	19	GND	Black	
Purple	BAT+	14	14				
Gray	BAT-	15	15				
Red	VCC	16	16				
Black	GND	17	17				
Blue	BKR-	20	20				
Yellow	BKR+	21	21				
-	-	-	22				

Shield is clamp connected to the hood

### Model Name CB-PAC-PIO□□□□

\* Please indicate the cable length (L) in □□□, (e.g. 080=8m) maximum 10m.

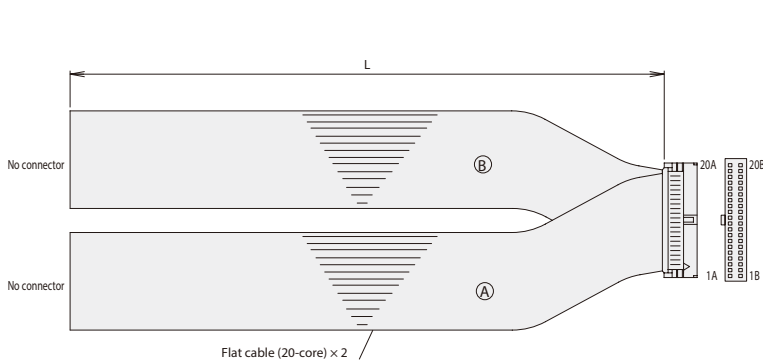

HIF6-40D-1.27R							
No.	Signal name	Cable color	Wiring	No.	Signal name	Cable color	Wiring
1A	24V	Brown-1	Flat cable (20-core) x 2 (pressure-welded)	1B	OUT0	Brown-3	Flat cable (20-core) x 2 (pressure-welded) AWG28
2A	24V	Red-1		2B	OUT1	Red-3	
3A	-	Orange-1		3B	OUT2	Orange-3	
4A	-	Yellow-1		4B	OUT3	Yellow-3	
5A	IN0	Green-1		5B	OUT4	Green-3	
6A	IN1	Blue-1		6B	OUT5	Blue-3	
7A	IN2	Purple-1		7B	OUT6	Purple-3	
8A	IN3	Gray-1		8B	OUT7	Gray-3	
9A	IN4	White-1		9B	OUT8	White-3	
10A	IN5	Black-1		10B	OUT9	Black-3	
11A	IN6	Brown-2		11B	OUT10	Brown-4	
12A	IN7	Red-2		12B	OUT11	Red-4	
13A	IN8	Orange-2		13B	OUT12	Orange-4	
14A	IN9	Yellow-2		14B	OUT13	Yellow-4	
15A	IN10	Green-2		15B	OUT14	Green-4	
16A	IN11	Blue-2		16B	OUT15	Blue-4	
17A	IN12	Purple-2		17B	-	Purple-4	
18A	IN13	Gray-2		18B	-	Gray-4	
19A	IN14	White-2		19B	0V	White-4	
20A	IN15	Black-2		20B	0V	Black-4	

# MEMO

A series of horizontal dotted lines for writing.

---

**IAI America, Inc.**

**US Headquarters:** 2690 W. 237th Street, Torrance, CA 90505 (800) 736-1712

**Chicago Office:** 110 E. State Pkwy, Schaumburg, IL 60173 (800) 944-0333

**Atlanta Office:** 1220 Kennestone Circle, Suite 108, Marietta, GA 30066 (888) 354-9470

**[www.intelligentactuator.com](http://www.intelligentactuator.com)**

The information contained in this product brochure may change without prior notice due to product improvements.

**IAI Industrieroboter GmbH**

Ober der Röth 4, D-65824 Schwalbach am Taunus, Germany

**IAI (Shanghai) Co., Ltd.**

Shanghai Jiahua Business Center A8-303, 808, Hongqiao Rd., Shanghai 200030, China

**IAI Robot (Thailand) Co., Ltd.**

825 Phairojkijja Tower 7th Floor, Bangna-Trad RD., Bangna, Bangna, Bangkok 10260, Thailand