

Datasheet

Subject to technical alteration
Issue date: 16.02.2018 • A003



Application

Battery-free wireless (EasySens® technology) valve actuator for individual room control. The new electronic heating valve utilizes the heat dissipation between the radiator and the space to gain electrical energy by means of a thermoelectric generator.

Types Available

Battery-free valve actuator EnOcean with thermal energy harvesting

SAB+

Security Advice – Caution



The installation and assembly of electrical equipment should only be performed by authorized personnel.

The product should only be used for the intended application. Unauthorised modifications are prohibited! The product must not be used in relation with any equipment that in case of a failure may threaten, directly or indirectly, human health or life or result in danger to human beings, animals or assets. Ensure all power is disconnected before installing. Do not connect to live/operating equipment.

Please comply with

- Local laws, health & safety regulations, technical standards and regulations
- Condition of the device at the time of installation, to ensure safe installation
- This data sheet and installation manual

Notes on Disposal



As a component of a large-scale fixed installation, Thermokon products are intended to be used permanently as part of a building or a structure at a pre-defined and dedicated location, hence the Waste Electrical and Electronic Act (WEEE) is not applicable. However, most of the products may contain valuable materials that should be recycled and not disposed of as domestic waste. Please note the relevant regulations for local disposal.

Technical Data

Radio Technology	EnOcean (IEC 14543-3-10)
Frequency	868 MHz
Antenna	internal transmitting/receiving antenna
Data transmission	bidirectional, airConfig ready
Power supply	maintenance-free thermal energy harvesting, micro-USB port (type B)
Measuring range temp.	0..+40 °C
Measuring interval	every 2..20 min., configured via airConfig, (in 1 min. steps)
Transmission interval	= Measuring interval
Functions	radio interface, actuator operation, self-control mode, automatic closing point control, frost protection function
Display	status-LED, red
Enclosure	PC, pure white, aluminium
Protection	IP40 according to EN 60529
Ambient condition	0..+50 °C, max. 85% rH non-condensing
Mounting	screw mounted, M30 x 1,5
Notes	configuration software "airConfig" can be downloaded from Thermokon website. EnOcean USB stick, (i.e. contained in the test tool airScan (item No. 566704) will be required to communicate. Integrated temperature sensor, Operational noise <35 dB(A), nominal stroke 3.8 mm, max. speed 0,24 mm/s, Min. force 100 N

Overview Radio Telegrams



EEP

The structure of the data contained in the telegram can be found in the EEP (EnOcean equipment profile) list provided by the EnOcean Alliance: <http://www.enocean-alliance.org/eep/>.

SAB+

A5-20-01

Mounting Advices and Commissioning

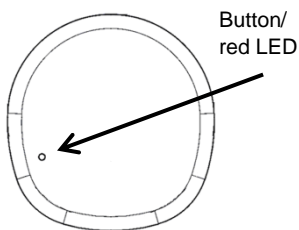

The SAB+ can be mounted directly on a standard valve with M30x1.5 thread. For mounting on valves with different mountings metal adapters are available on request.

In the delivery state, the pin of the device should be fully retracted. If not, press the button for approx.. 3..6 sec. by means of a thin pin (see button opening). If the valve pin is not fully retracted, the valve actuator cannot be installed correctly to the thermostat valve.

Teach-in process

The teach-in process of the SAB + to the gateway (MSG server) corresponds to the battery powered model SAB05.

1. Remove the valve drive from the radiator and install the SAB+.
→ *This is important so that the valve drive can correctly perform the reference operation.*
2. Set the gateway (MSG server) to the teach-in mode.
→ *(See instructions for radio receivers)*
3. Press the SAB+ learn button once. The sensor will be learned into the MSG Server and vice-versa.
→ *Possibly a manual triggering of a learn-in telegram of the gateway is necessary in order to teach it into the valve drive. Please note the instructions of the gateway.*
→ *The successful teach-in is confirmed by a single flashing of the LED.*
→ *If the LED flashes 3 times, the learning process must be repeated.*
4. The SAB+ performs automatically a reference run to identify the mechanical limits (valve fully closed, fully open) and starts normal operation.

Function Description

By default the SAB+ communicates with the room controller every 10 minutes to receive a new position or – if in self-controlled mode - setpoint and room temperature. The communication interval can be set using the airConfig software tool from 2 min up to 20 min by increments of 1 min.

In case of loss of communication SAB+ does switch to self-controlled mode using the parameters set by airConfig.

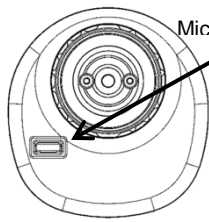

In the unlikely event of insufficient power status SAB+ will move to the “valve safe position” to harvest energy.

A micro-USB port (type B) is located on the inside of the valve actuator. Via this connection, the internal battery of the device can be charged directly to the socket via a USB power supply. The duration for completely charge is about 3.5 hours.

Configuration via airConfig

airConfig version 5.03.03 or newer is necessary to configure the SAB + valve actuator.

After pressing the LRN-Button SAB+ will show up at the sensor tab first and after few seconds, when all parameters have been read in the devices list.

Valve safe position

Fixed, pre-set position in which the valve actuator operates when the internal power supply is lost.

Set point on communication loss

Set point that the valve actuator uses as long as the communication is lost for the self-controlled mode.

Ki

Increase Ki until the steady-state error with respect to the setpoint is corrected fast enough, without affecting the initial dynamics too much. Typical value = 100

Kp

Raise Kp until the system's response is sufficiently fast to track step changes in your setpoint. This proportional component of a PID defines the 'stiffness' of your control system's response. Typical value = 10

Kd

Raise Kd until the system's response is adequately damped. You don't need this if you don't have an overshoot. This component defines an artificial damping for your system. Typical value = 0

Temperature offset

The valve actuator is mounted directly on the radiator, therefore the measured temperature most likely will be too high. The set value is subtracted from the internal sensed value.

RF interval

The transmission/reception interval can be set in 1 min increments from 2 min up to 20 min. Please note that more frequent transmission results in higher energy consumption which may exceed the amount of harvested energy. In this case the valve will move to the safe position and may stop working until the internal energy buffer is sufficiently charged.

Factory Reset:

Resets the device to factory settings.

Status Tab

Settings	Status
Storage/Supply voltage:	<input type="text" value="0.0"/> V
Harvester voltage:	<input type="text" value="0"/> mV
Motor distance count:	<input type="text" value="0"/>
Motor move counts:	<input type="text" value="0"/>
Error state:	<input type="text" value="no error"/>
Valve safe position:	<input type="checkbox"/>
Summer mode:	<input type="checkbox"/>

The Status tab provides information on the characteristics performed so far.

Voltage of the internal storage will be displayed as well as the harvester voltage.

Motor distance counts (incremental steps) and move counts (incremented by 1 when leaving the current position and travel to a new position)

Valve safe position (Info Box)

Fixed, pre-set position in which the valve actuator operates when the internal power supply is lost.

Summer Mode (Info Box)

Reduces the energy consumption by extending the wake-up interval to 8h.

Unmounting / RESET

To unmount the SAB+ from the valve, press the button for approx. 3..6 seconds. The SAB+ will move in the mounting position with the stem fully retracted and stops communicating until the LRN button is pressed again.

Self-control mode in case of Communication Loss

In case the MSG-Server does not respond to the request issued by SAB+ the current valve position will be maintained until the MSG-Server failed to respond for the 9th time. After 9 telegrams w/o answer SAB+ will switch to self-controlled mode and calculated the valve position internally, using the internal temperature sensor and the "Set point on communication loss", which can be modified by airconfig. Once per hour SAB+ will try to re-establish the communication with the MSG-Server. Once the MSG-Server answers again the self-controlled mode will be stopped and the normal operation will be restarted,

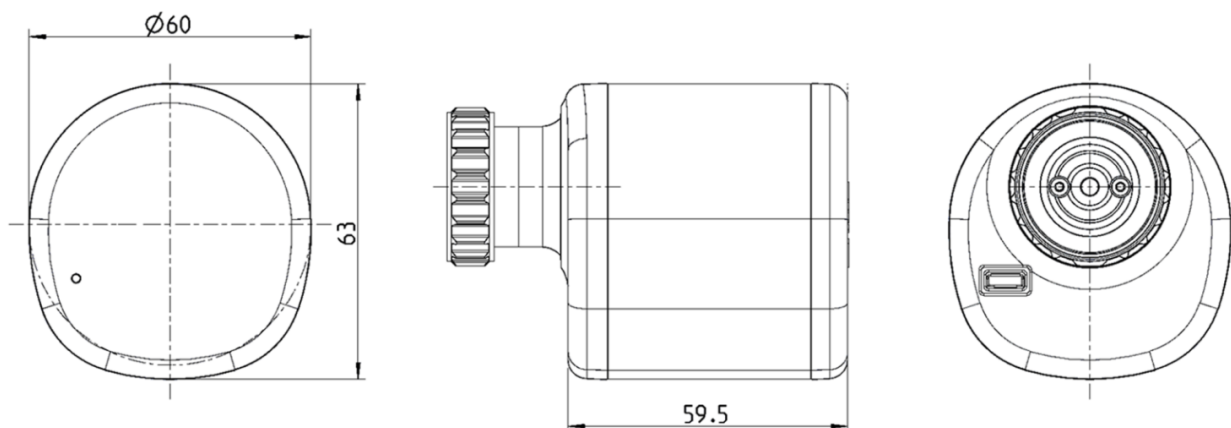
Dimensions (mm)**Accessories (optional)**

SAB-Lock (thread locking)

Item No. 688611