

## » VFG54+

Contact temperature sensor

**thermokon**<sup>®</sup>  
HOME OF SENSOR TECHNOLOGY

### Datasheet

Subject to technical alteration  
Issue date: 13.05.2019 • A100

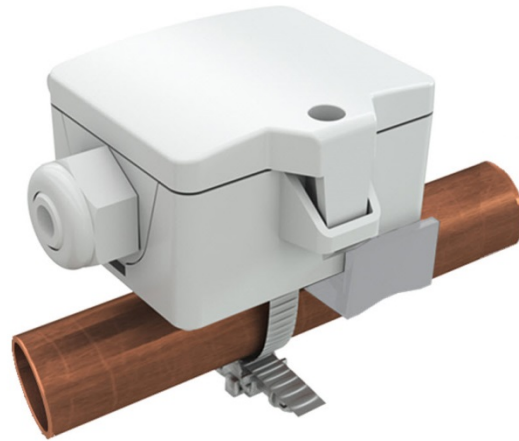

### » APPLICATION

Sensor with hinged lid enclosure USE for temperature measurement of pipes and round surfaces. Spring loaded brass contact sensor.

### » TYPES AVAILABLE

#### Contact sensor temperature – passive

VFG54+ <sensor>

#### Contact sensors temperature – active TRV 0..10 V | TRA 4..20 mA

VFG54+ TRV MultiRange

VFG54+ TRA MultiRange

<sensor>: PT100/PT1000/NI1000/NI1000TK5000/LM235Z/NTC.../PTC... other sensors on request

MultiRange: Measuring ranges adjustable at the transducer

### » SECURITY ADVICE – CAUTION



The installation and assembly of electrical equipment should only be performed by authorized personnel.

The product should only be used for the intended application. Unauthorised modifications are prohibited! The product must not be used in relation with any equipment that in case of failure may threaten, directly or indirectly, human health or life or result in danger to human beings, animals or assets. Ensure all power is disconnected before installing. Do not connect to live/operating equipment.

Please comply with

- Local laws, health & safety regulations, technical standards and regulations
- Condition of the device at the time of installation, to ensure safe installation
- This data sheet and installation manual

## » NOTES ON DISPOSAL



As a component of a large-scale fixed installation, Thermokon products are intended to be used permanently as part of a building or a structure at a pre-defined and dedicated location, hence the Waste Electrical and Electronic Act (WEEE) is not applicable. However, most the product may contain valuable materials that should be recycled and not disposed of as domestic waste. Please note the relevant regulations for local disposal.

## » GENERAL REMARKS CONCERNING SENSORS

Especially with regard to passive sensors in 2-wire conductor versions, the wire resistance of the supply wire has to be considered. If necessary the wire resistance has to be compensated by the follow-up electronics. Due to self-heating, the wire current affects the measurement accuracy, so it should not exceed 1 mA.

When using lengthy connection wires (depending on the cross section used) the measuring result might be falsified due to a voltage drop at the common GND-wire (caused by the voltage current and the line resistance). In this case, 2 GND-wires must be wired to the sensor - one for supply voltage and one for the measuring current.

Sensing devices with a transducer should always be operated in the middle of the measuring range to avoid deviations at the measuring end points. The ambient temperature of the transducer electronics should be kept constant. The transducers must be operated at a constant supply voltage ( $\pm 0,2$  V). When switching the supply voltage on/off, onsite power surges must be avoided.

## » BUILD-UP OF SELF-HEATING BY ELECTRICAL DISSIPATIVE POWER

Temperature sensors with electronic components always have a dissipative power, which affects the temperature measurement of the ambient air. The dissipation in active temperature sensors shows a linear increase with rising operating voltage. This dissipative power has to be considered when measuring temperature. In case of a fixed operating voltage ( $\pm 0,2$  V) this is normally done by adding or reducing a constant offset value. As Thermokon transducers work with a variable operating voltage, only one operating voltage can be taken into consideration, for reasons of production engineering. Transducers 0..10 V / 4..20 mA have a standard setting at an operating voltage of 24 V =. That means, that at this voltage, the expected measuring error of the output signal will be the least. For other operating voltages, the offset error will be increased by a changing power loss of the sensor electronics. If a re-calibration should become necessary later directly on the sensor, this can be done by means of a trimming potentiometer on the sensor board.

**Remark: Occurring draft leads to a better carrying-off of dissipative power at the sensor. Thus temporally limited fluctuations might occur upon temperature measurement.**

## » MOUNTING ADVICES

The device is fixed using the tightening strap. Use contact fluid for better heat transfer between sensor and measuring medium. To avoid permeation of condensate, mount the sensor on top of the tube, if possible. The installation is possible in or across the direction of the pipe.

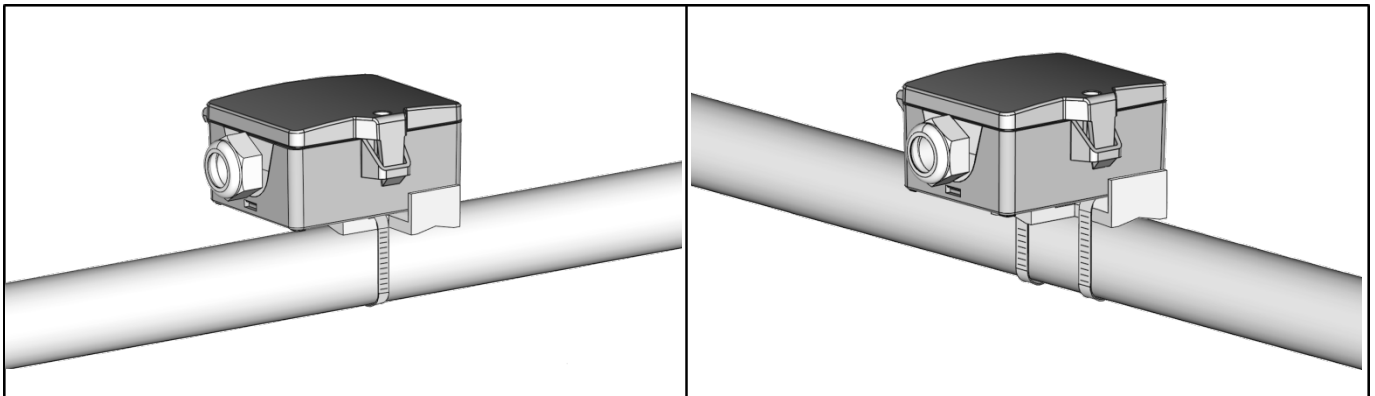

## » USE ENCLOSURE WITH UV AND WEATHER RESISTANCE

After some time, outdoor mounted plastics can lose their color and quality. Therefore, all USE housings are made of special white polycarbonate (PC). The light-stable colorants and additives are used to achieve optimum protection of the polymer while maintaining color stability. The titanium dioxide used is specially developed for polycarbonate and offers excellent UV protection through the reflection of the entire light spectrum including the UV component by 340 nm. This effectively counteracts the otherwise occurring photochemical polymer degradation. The colors stay full for a long time without fading. The material is also resistant to cold and frost.

## » TECHNICAL DATA

Measuring values	temperature		
Output voltage	<b>TRV</b> 1x 0..10 V or 0..5 V, configurable via jumper, min. load 5 k $\Omega$		
Output ampere	<b>TRA</b> 1x 4..20 mA, max. load 500 $\Omega$		
Output passive	<b>passive</b> PT100   PT100 1/3 DIN   PT1000   PT1000 1/3 DIN   Ni1000   Ni1000TK5000, NTC10k   NTC 10k Precon   NTC5k   NTC20k   NTC1,8k, LM235Z   DS18B20 1-wire, KTY81-110   KTY81-121   KTY81-122   KTY81-210		
Power supply	<b>TRV</b> 15..24 V = ( $\pm 10\%$ ) or 24 V ~ ( $\pm 10\%$ ) SELV	<b>TRA</b> 15..24 V = ( $\pm 10\%$ ) SELV	
Power consumption	<b>TRV</b> typ. 0,4 W (24 V =)   0,8 VA (24 V ~)	<b>TRA</b> typ. 0,5 W (24 V =)	
Measuring range temp.	<b>passive</b> -35..+90 °C		
Output signal range temp. *Scaling analogue output	<b>TRV   TRA</b> default setting: 0..+100 °C, selectable from 8 temperature ranges -50..+50   -20..+80   -15..+35   -10..+120   0..+50   0..+100   0..+160   0..+250 °C, adjustable at the transducer		
Operating temperature range * Max. permissible operating temperature	<b>sensor pocket   holder</b> -35..+120 °C	<b>enclosure   electronic – TRV TRA</b> -35..+70 °C	<b>enclosure   electronic – passive</b> -35..+90 °C
Accuracy temperature	<b>TRV   TRA</b> $\pm 0,5$ K (typ. at 21 °C within default measuring range)		<b>passive</b> typ. $\pm 0,3$ K (typ. at 21 °C), depending on used sensor
Sensor	<b>passive</b> optional, 2-wire (default), 3-wire or 4-wire		
Enclosure	enclosure USE-S, PC, pure white		
Protection	IP65 according to EN 60529		
Cable entry	Flextherm M16, for wire $\varnothing=3.7$ mm, removable		
Connection electrical	removable plug-in terminal, max. 2,5 mm <sup>2</sup>		
Pocket	brass, spring loaded sensor		
Ambient condition	max. 85% rH short term condensation		
Mounting	can be mounted in line or transversely to the pipe		

## » PRODUCT TESTING AND CERTIFICATION



### Declaration of conformity

The declaration of conformity of the products can be found on our website <https://www.thermokon.de/>.

## » CONNECTION PLAN AND CONFIGURATION

The adjustment of the measuring ranges is made by changing the jumpers in a de-energized state. The output value of the new measuring range is available after 2 seconds.

Passiv

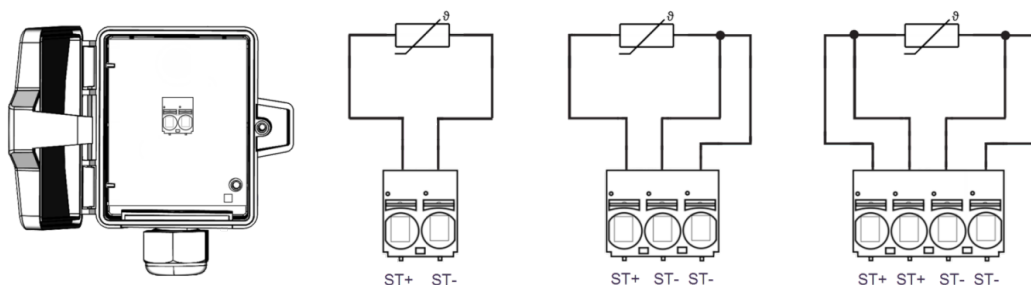

TRA:  
4..20 mA

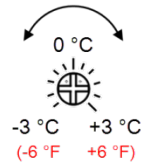
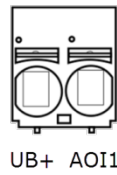
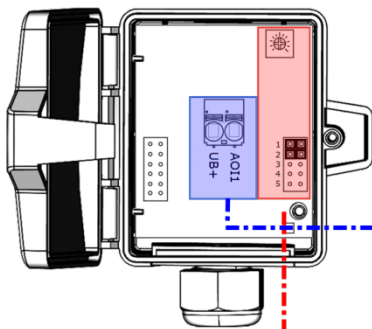

TRV:  
0..10 V | 0..5 V

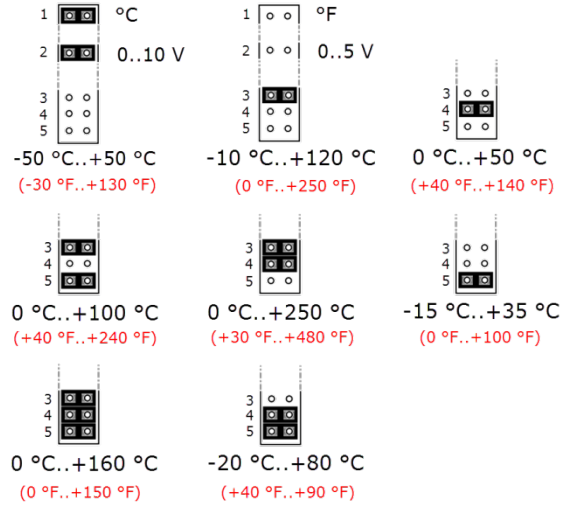
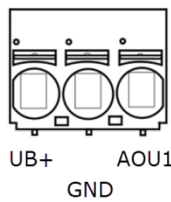
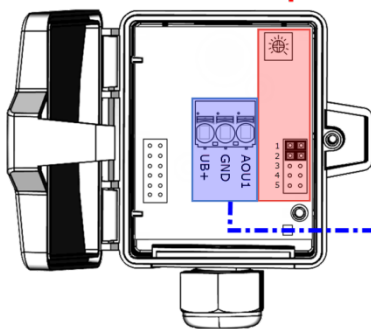
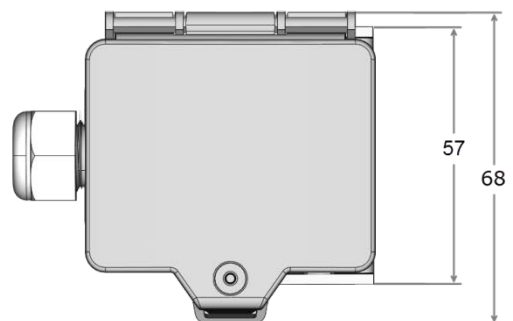
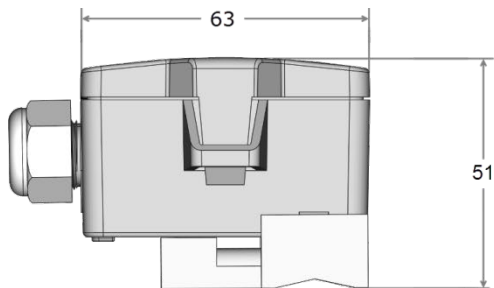

fig. (Measuring range and offset adjustment, default settings: 0 °C..+100 °C | 0 K)

» DIMENSIONS (MM)



» ACCESSORIES (OPTIONAL)

- Tension clamp for pipes Ø up to 110 mm with contact fluid
- Tension clamp for pipes Ø up to 250 mm with contact fluid
- Tightening strap PA for pipes Ø up to 100 mm with contact fluid
- M16 Sealing inserts cable entry (packaging unit 10 pcs.) for wire with Ø 8 mm

- Item No. 658911
- Item No. 648103
- Item No. 668071
- Item No. 641340