



Foot switch with metal enclosure

GFSM 2 1ÖS/1ÖS

Material number: 1048877 (Material number old: 82206001)

Features/Options

- 2-pedal type
- With protective shield
- Metal enclosure
- Low pedal height
- Wiring compartment

Dimensions

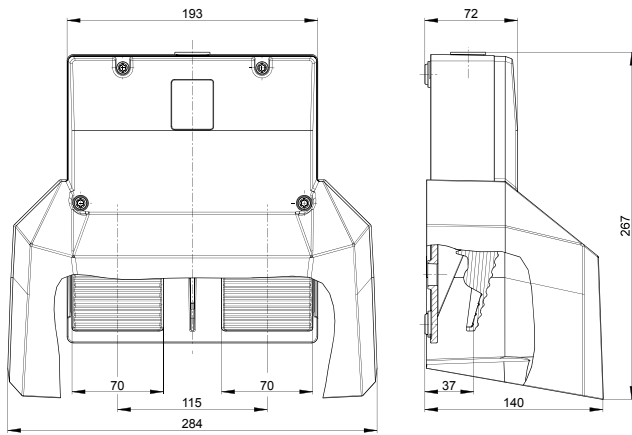

Technical data

Standards	EN ISO 13849-1; EN 60947-5-1
Enclosure	aluminium die-cast, enamel finish, RAL 5011
Pedal	glass-fibre reinforced thermoplastic
Protective shield	aluminium die-cast, enamel finish, RAL 5011
Connection	screw connection terminals
Cable cross-section	max. 2.5 mm ² (incl. conductor ferrules)
Cable entry	1 x M25 x 1.5
Contact material	silver
Degree of protection	IP 65 to IEC/EN 60529
Switching system	snap action with double break, positive break NC contacts ⊖
Switch insert	1 x ZS 232 per pedal
B_{10d} (10 % Load)	2 million
T_M	max. 20 years
Utilisation category	AC-15
I_e/U_e	4 A/230 VAC; 2.5 A/400 VAC; 1 A/500 VAC
Max. fuse rating	4 A gG/gN fuse
Ambient temperature	-25 °C ... +80 °C
Mechanical life	> 1 million operations
Approvals	
Weight	1000 g

Errors and omissions excepted.

Contact diagram

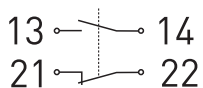

Switching diagram

