



Foot switch with metal enclosure

GFS 10/1S RE

Material number: 1048587 (Material number old: 81201601)

Features/Options

- With latching: ON/OFF principle
- Metal enclosure
- With protective shield

- High level of stability
- Low pedal height
- Wiring compartment

Dimensions

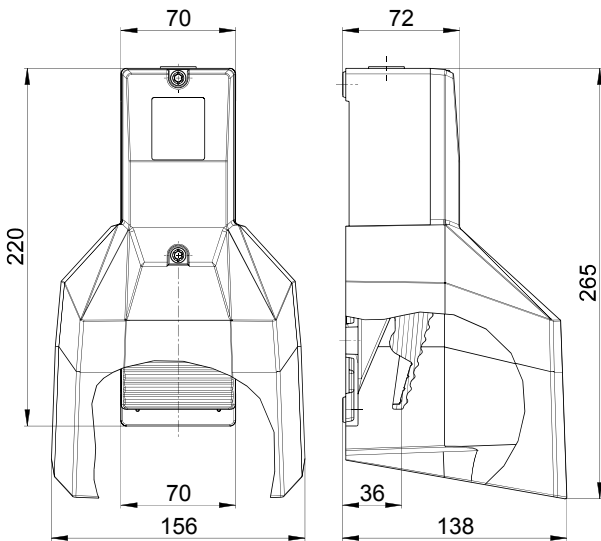

Technical data

Standards	EN 60947-5-1
Enclosure	aluminium die-cast, enamel finish, RAL 5011
Pedal	glass-fibre reinforced thermoplastic
Protective shield	aluminium die-cast, enamel finish, RAL 5011
Connection	screw connection terminals
Cable cross-section	max. 2.5 mm ² (incl. conductor ferrules)
Cable entry	1 x M20 x 1.5
Contact material	silver
Degree of protection	IP 65 to IEC/EN 60529
Switching system	slow action with double break, positive break NC contacts ⊖
Switch insert	ES 60 GF RE
Switching elements	1 NC/1 NO contact with latching
Utilisation category	AC-15
I_e/U_e	16 A/400 VAC
Max. fuse rating	16 A gG/gN fuse
Ambient temperature	-25 °C ... +80 °C
Mechanical life	> 1 million operations
Approvals	
Weight	1000 g

Errors and omissions excepted.

Contact diagram

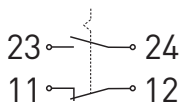

Switching diagram

