

TIB Progressive Code	Product	Date
TIB_13	MOSAIC 3.0 - new firmware and MSD functions	23/02/2016
Description	New firmware version 3.0 New functions for MSD (Mosaic Safety Designer) software - Ver. 1.4.	
Object	Preview of the new modules and features of the software program	

New Firmware version (3.0)

- Mosaic Modules M1 ver. 3.0 and MI802 Ver. 0.9, can handle 2 Guard Locks on the status output in addition to those available on the OSSD, bringing the total to three. Modules with versions previous to 3.0 had the limitation of a single guard lock.
- Two new modules for automation have been added: MOS8/MOS16.
 - MOS8 - 8 non-safety status output. PNP 100 mA.
 - MOS16 - 16 non-safety status output. PNP 100 mA.
- Maximum number of timer outputs: 32. Increasing from 16 to 32.



1. MOS8 and MOS16 Modules

New functions for MSD "Mosaic Safety Designer"

The new release 1.4 of MSD software integrates some new functions:

- "New operator - Logical Macro" see page 2
- "New operator - Macro Restart" see page 2
- "New Timer Operators" see page 2
- "New Flip-Flop T operator" see page 4
- "New Reset M1 operator" see page 4
- "Guard Lock operator update" see page 4
- "New Flip-Flop T operator" see page 4
- "MUTING Con operator modifications" see page 5
- "OUTPUT OSSD update" see page 5
- "Network_In input has been added" see page 6
- "Operators Speed Monitoring" see page 6
- "Mosaic error log update" see page 7
- "Configuration" see page 7



Note: To download the Mosaic Safety Designer software, use the following link:
http://www.reer.it/reer/pdf/Software/msd_setup.zip

The software downloaded from this address is always up-to-date and refers to the latest version released.

If you want to know in advance which is the latest version available for download, click the link here below:

http://www.reer.it/reer/pdf/Software/MOSAIC_LAST_VER.txt

New operator - Logical Macro

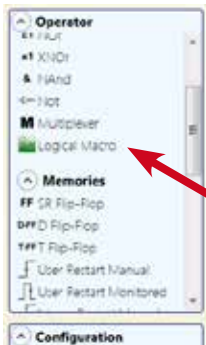

Groupings can be created with a maximum of three operators of different types for a total of max. 8 inputs.

This allows to increase the maximum number of operators used (now 64).

With the introduction of the macro you have an average increase of about 30% of the number of operators.

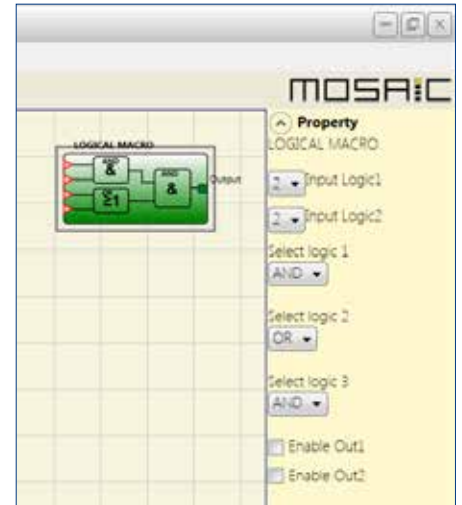

New operator - Restart Macro

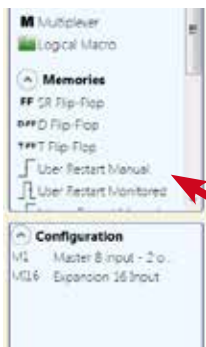

It includes a logical operator with a maximum of 7 inputs and the restart operator.

It can also be set as manual restart.

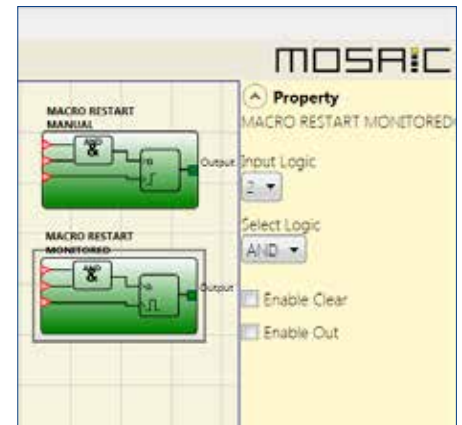

New Timer Operators

Warning: The number of Timer operators configurable on the system increases from 16 to 32.

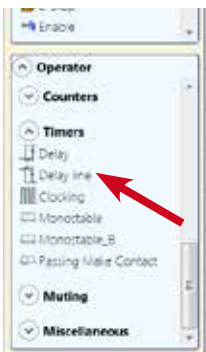

Delay Line

When the signal IN is moved to 0 logic level, this operator inserts a delay to a signal carrying the output OUT to 0 after the time set.

If before the end of the set time the input IN returns to 1, the output OUT still generates a pulse signal with this duration: about 3 times the response time plus the delayed time set.

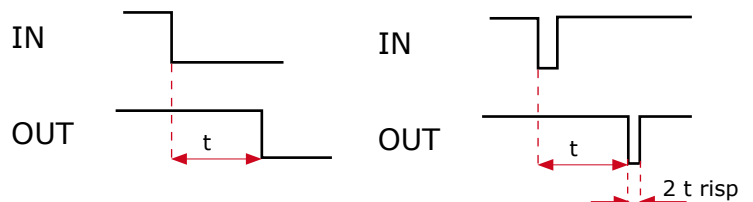
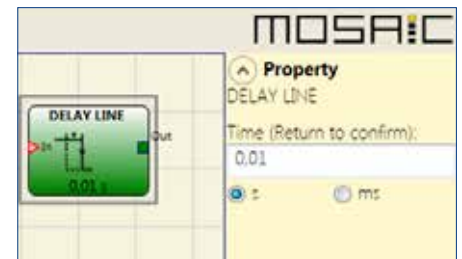

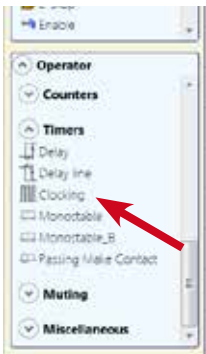

New Clocking Operator

This operator has up to 7 inputs to control the output Duty Cycle.

Related to the selected input, this operator will generate a clock with different duty cycle.

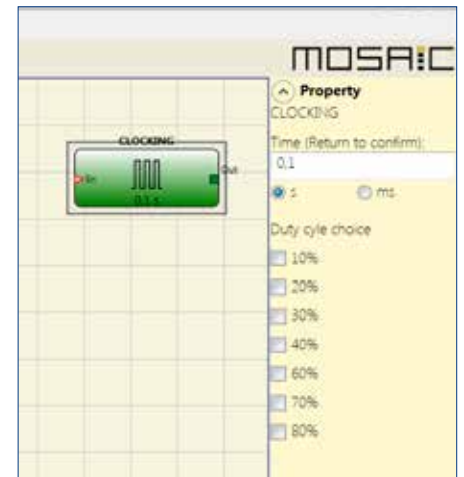
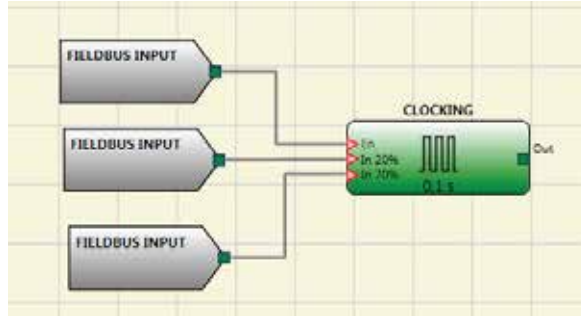

Note: It can be used, for example, to pass or receive the status information to or from a PLC.

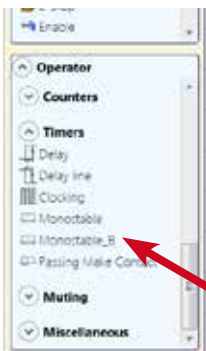
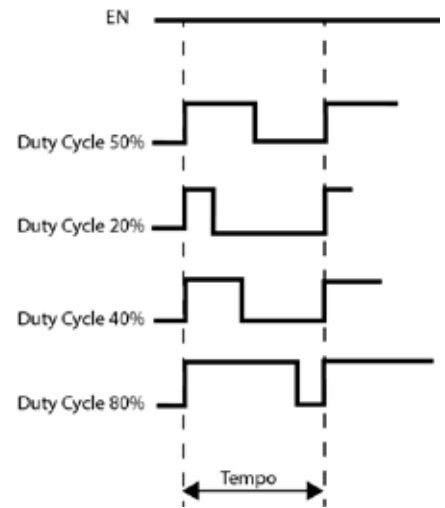

New Monostable B operator

The operator MONOSTABLE supplies the "out" output with a logic level 1 (TRUE) which is triggered by the rising edge of the signal on input "In". The logic level 1 remains for the duration of the set time.

Retriggerable: If selected, enables the option to repeat the command also before the end of the set time t.

Rising edge: If selected provides a high level output (1) OUT if detected a rising edge on the input IN. If unchecked provides a high level output (1) OUT when detected a falling edge at the input IN.

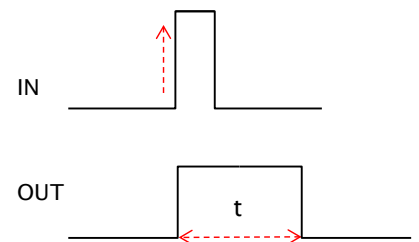

New Flip-Flop T operator

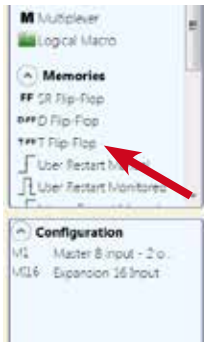

The operator T FLIP FLOP stores the status of the Q output (Toggle).

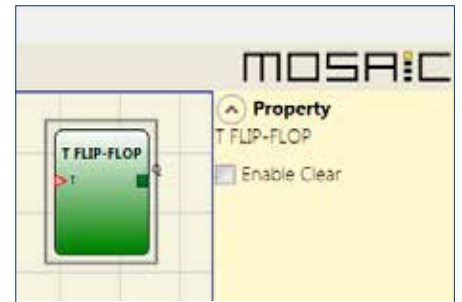

New Reset M1 operator

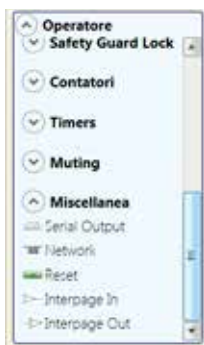

This operator resets the MOSAIC system in presence of errors on the inputs or outputs.

This operator generates a reset of the system when the corresponding input is a double transition OFF-ON-OFF of less than 5s.

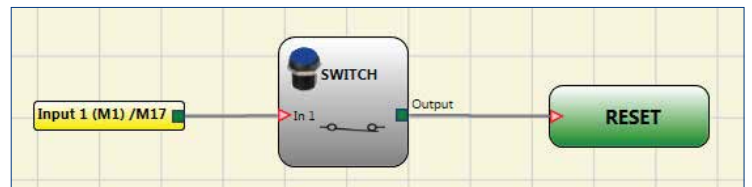
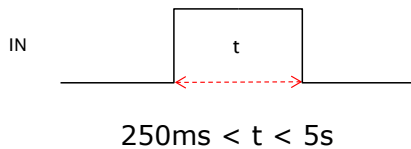

Guard Lock operator update

This new version of MSD, removes the limitation of a single Guard lock on M1 and MI802 models. It is now possible to insert one Guard lock on an OSSD and the other two on the outputs status.



NOTE: On MO2 and MO4 modules it is possible to connect maximum 2 Guard locks (one on an OSSD and the other one on the output status).

GuardLock new options:

- *Mandatory gate opening.* A new option has been introduced. In this case, the correct unlock sequence becomes:

- Unlock the lock
- Opening gate mandatory
- Closing gate
- Lock.

The unlock sequence without this option is instead:

- Unlock the lock
- Opening gate (optional)
- Closing gate (optional)
- Lock.

- *Gate not present.* The Guard Lock can be configured without Gate, but only with the Feedback.

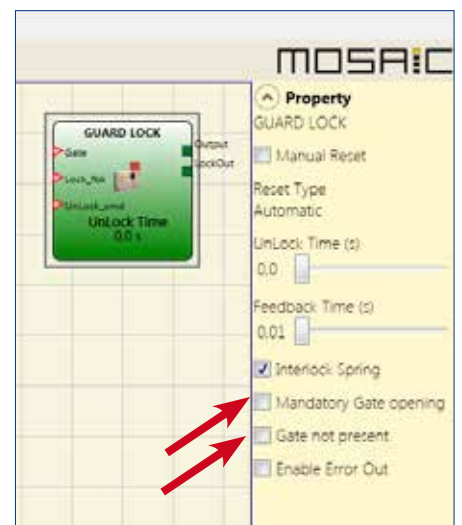

MUTING "Con" operator modifications

Thanks to this operator you can set the "contemporary logic" muting. The activation of the Muting function occurs following interruption of the sensors S1 and S2 beams and then of the sensor S3 and S4 within a time range from 2s and 5s for each couple of sensors. The sequence is:

S1 --X sec. --> S2 ---t---S3 --X sec. --> S4

Where t is a value that depends on the "timeout", X is the "sensor time".

In this version we added the Minimum sensors time option that allows you to stop the muting function if the passage in front of the sensors 1-2 and 3-4 takes place with a time less than 150 ms. In this way it is possible to detect the transit of a person who normally moves with a speed of 1.6 m/s (speed certainly superior to that of the pallet).

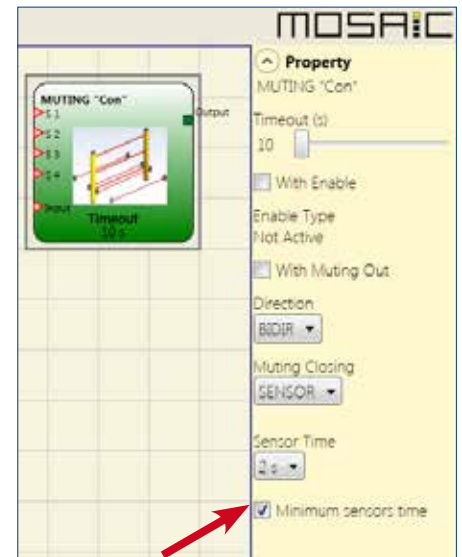

OUTPUT OSSD update

Output1 e Output2 supply:

- 24VDC if IN = 1, viceversa
- 0VDC if IN = 0.

Each OSSD has a related RESTART_FBK

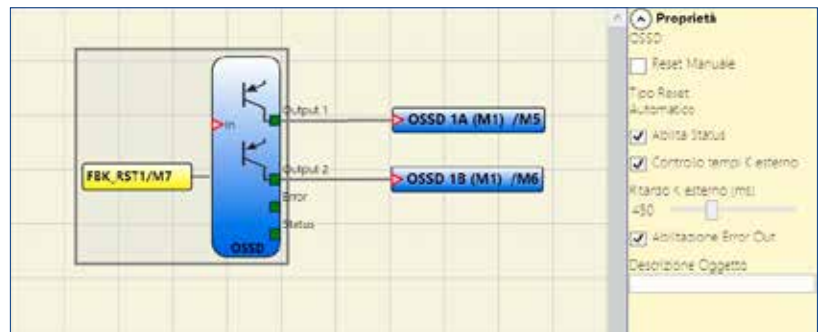

In the new version of MSD:

External K time monitoring. Monitor of the feedback delay it's now possible. For example in solenoid valves control.

If selected, the external feedback signal (relative to output status) will be monitored and it's possible selecting the time length of the monitor.

With a high level OUTPUT (1), the FBK signal must be at low level (0) and vice versa.

Otherwise the OUTPUT output goes low (0) and the fault is signalled to the master M1 with the flashing CLEAR LED of the fault OSSD.

Enable Error Out. If selected the Error out output will be enabled. This output goes logic level high (1) when the external FBK signal error is detected.

The Error Out signal is reset upon the occurrence of one of these events:

- Turn off and turn on of the system.
- M1 reset with the RESET operator.

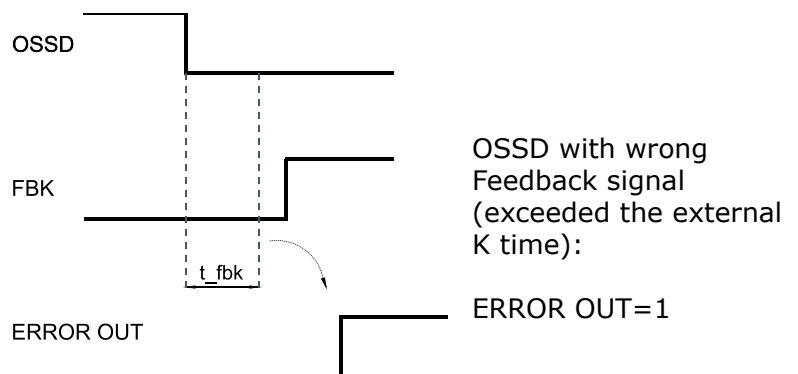
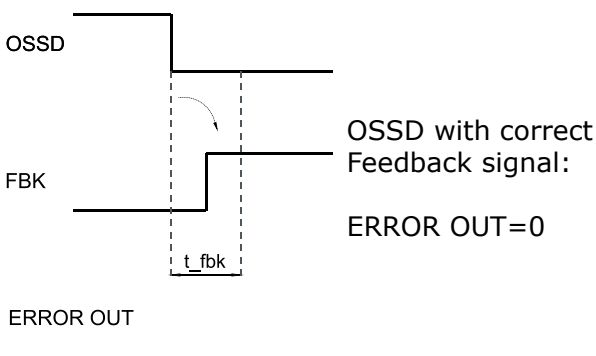

Network_In input has been added

In order to improve the management of the network connection, new NetworkIn input has been added. This

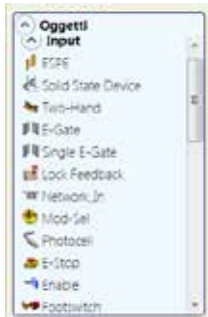

input must be used in case of connection between Mosaic OSSD output and the input of another Mosaic.

This function block realizes a network input interface connection, generating on the OUT output a logical level high (1) when the line is high, 0 otherwise.

This input can only be allocated to M1.

The following diagram illustrates the use of this input object.



They must be physically connected terminals related to an output OSSD or the first Mosaic system status to Network_in inputs of the second Mosaic system.

Operators Speed Monitoring

The number of threshold in case of "Linear" axis and "linear" type of encoder becomes 4.

The speed limit changes from 250 mm/s to 2000 mm/s.

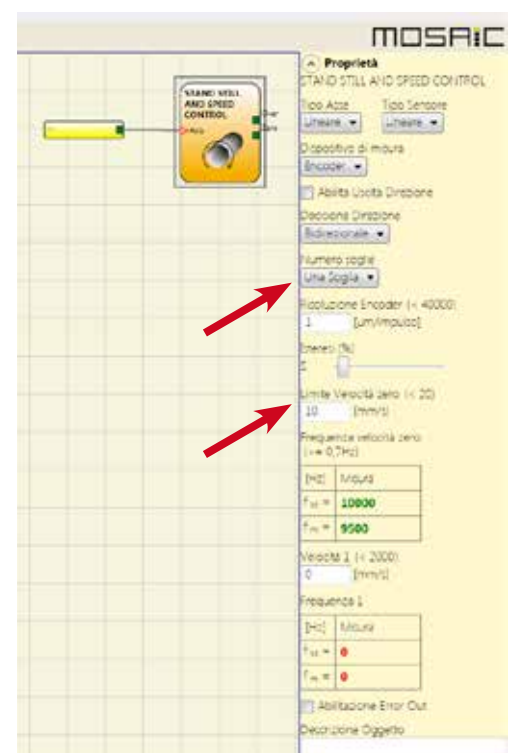

Mosaic error log update

Visualisation and management of the Mosaic Error Log has been added. The log file keeps recorded up to 5 errors.

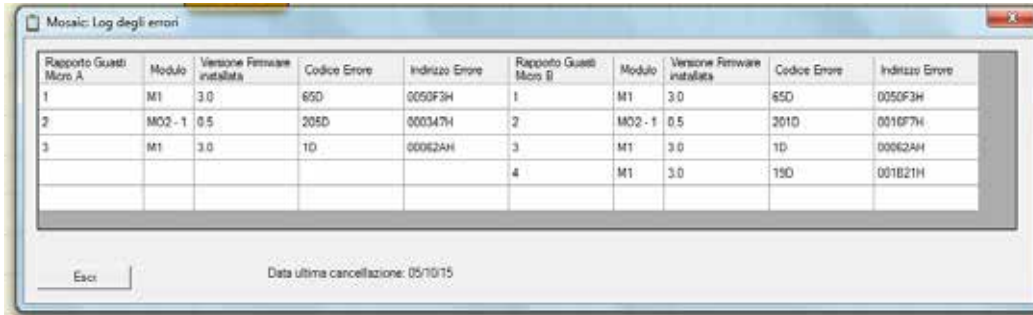

Rapporto Guasti Micro A					Rapporto Guasti Micro B				
	Modulo	Versione Firmware installata	Codice Errore	Indirizzo Errore		Modulo	Versione Firmware installata	Codice Errore	Indirizzo Errore
1	M1	3.0	65D	0050F3H	1	M1	3.0	65D	0050F3H
2	MO2-1	0.5	205D	000347H	2	MO2-1	0.5	201D	0016F7H
3	M1	3.0	1D	00062AH	3	M1	3.0	1D	00062AH
					4	M1	3.0	15D	001B21H

Esci Data ultima cancellazione: 05/10/15

Configuration

The automatic sort of entered modules in the Mosaic system configuration has been disabled. The module inserted remains in the position indicated by the user.

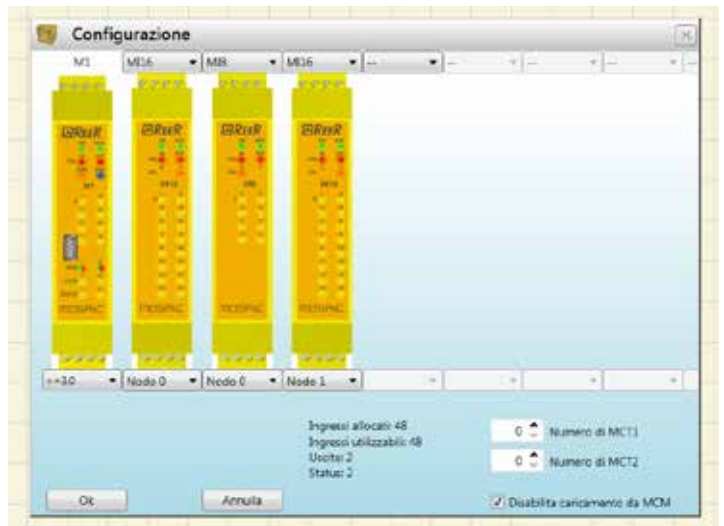

Other improvements

- The "system" Command creates a table with the required modules installed, ordered by name for better understanding.
- The pin assignment is checked run time. It verifies that the numbers assigned to the inputs and outputs are consecutive. Otherwise, a message is issued.
- Test outputs of the input objects that provide this test (switch, sensor, and stop) can be used to connect up to 4 different inputs. In the previous versions these were only two.
- In this software version it is possible to define the simultaneity control for the input object MOD SEL. From 10 ms to 7000 ms.

