Product bulletin for:

The BL10000

Tight sealing 2-way lug butterfly valve



BL10000 in conjunction with the S70M electric actuator

Developed for HVAC applications

Energy, the right amount to the right place at the right time



Product bulletin issue date: 0215

Bray Armaturen & Antriebe Europa
Commercial Division
Europark Fichtenhain A 13b

47807 Krefeld

Germany

Tel.: +49 2151 5336 111

Fax.: +49 2151 5336 199

Mobil:+49 162 4363713

This product bulletin contains the following:

- ***A list of features***
- ***A valve cross-sectional view***
- ***Ordering codes for valves***
- ***Ordering codes for valve actuators***
- ***A description of application***
- ***A valve selection table***
- ***Flow characteristic graphs***
- ***Specification tables***

1 Contents

1	Contents	2
2	Introduction	3
2.1	Your benefits for greater energy efficiency.....	3
2.2	Application	3
2.3	Properties	3
3	Technical description	5
3.1	Manually operated positioning with lever and manual gearbox	8
3.2	Combination with the S70M electric actuator	9
3.2.1	Electrical OEM standard damper actuators with and without spring return.	12
3.2.2	Function	13
3.2.3	Project planning and mounting instruction	13
3.2.4	Additional operational information	13
3.2.5	Pressure Equipment Directive – PED	13
4	K _v /flow diagram and flow characteristic diagrams.....	14
5	Drawings and dimension tables [mm]	19
5.1	BL10000 DN 50 to DN 300.....	19
5.2	BL10000 DN 350 to DN 500.....	19
5.3	DN 50 to DN 500 dimension table	20
5.4	BV00xM operating lever and BV00xG gear operator	21
5.5	S70M Actuator 006, 020, 050, 065.....	22
5.6	S70M Actuator 130,180.....	23
5.7	RA Electric Rotary Actuator DN 50 up to DN 100	24
5.8	RA Electric Rotary Actuator DN 125 up to DN 200	25
5.9	Universal OEM linkage kit	26
6	General information	27
6.1	General	27
6.2	Copyright protection	27
6.3	Original product Series 31	27

Introduction

2 Introduction

2.1 Your benefits for greater energy efficiency

- Intelligent seat and disc design for function at the lowest possible torque. Reduced torque extends life time and minimizes actuator size.
- The nylon-11 butterfly valve disc coating reduces loss that is due to friction and reduces costs of additional material variants for salt-water, well-water etc.
- Low Δp for reduced pumping cost.
- Tolerant of moderate levels of contamination in the fluid.
Lighter, more compact (short face-to-face) and thus less material needed for system construction than in globe valves.

2.2 Application

This shut-off and regulating equipment is specially designed and tailored to the needs of the HVAC market and finds use in the following areas:

- Cold and hot water applications.
- Water with a 50% max. glycol (water quality as per VDI 2035).
- Open water circuits such as:
 - Well water
 - Salt water
- The BL10000 standard delivery is with lugged valves. However, wafer valves are available on request.
- Dead-End Service (No downstream flanges and disc in closed position):
All BL10xxx Valves (with Standard Disc):
DN 50 up to DN 300mm 5.2 Bar
DN 350 up to DN 500 3.4 Bar

2.3 Properties

- Body: 16 bar nominal pressure.
- The GGG40, ductile iron housing is protected from corrosion by a polyester coating.
- A secured and continuous shaft with acetal bearing journal and U – formed seal.
- Fits to PN16 flanges.
- Nominal sizes from DN50 to DN500. Larger sizes available on request.
- Valve disc bubble tight up to 10/12bar.

-
- For systems where low close-off pressures are necessary we recommend you use the BL11000. This valve model has a reduced-diameter butterfly-valve disc with a max. close-off pressure of 350 kPa (3.5 Bar), thus requiring lower unseating torque. This means that lower actuator torque is required so that smaller actuators can be used.
 - Very low maintenance.
 - From size DN 100 an additional model with a torque-optimized valve disc, bubble tight up to 3.5bar for reduced unseating torque.
 - K_{vs} values from 36 m³/h to 19212 m³/h are available.
 - The flow characteristic is near equal percent up to 70° disc angle.
 - Manually operated butterfly valves:
 - Manual lever operation up to DN 300
 - Manual operation with gearbox DN 50 to DN 500
 - The Bray S70M motor drive also suitable for HVAC and industrial environment.
 - Modified kits for damper actuators prepared.
 - The fluid does not come into contact with the body.
 - The fluid is in contact only with the valve disc and seat and secondary stem seal.

Technical description

3 Technical description

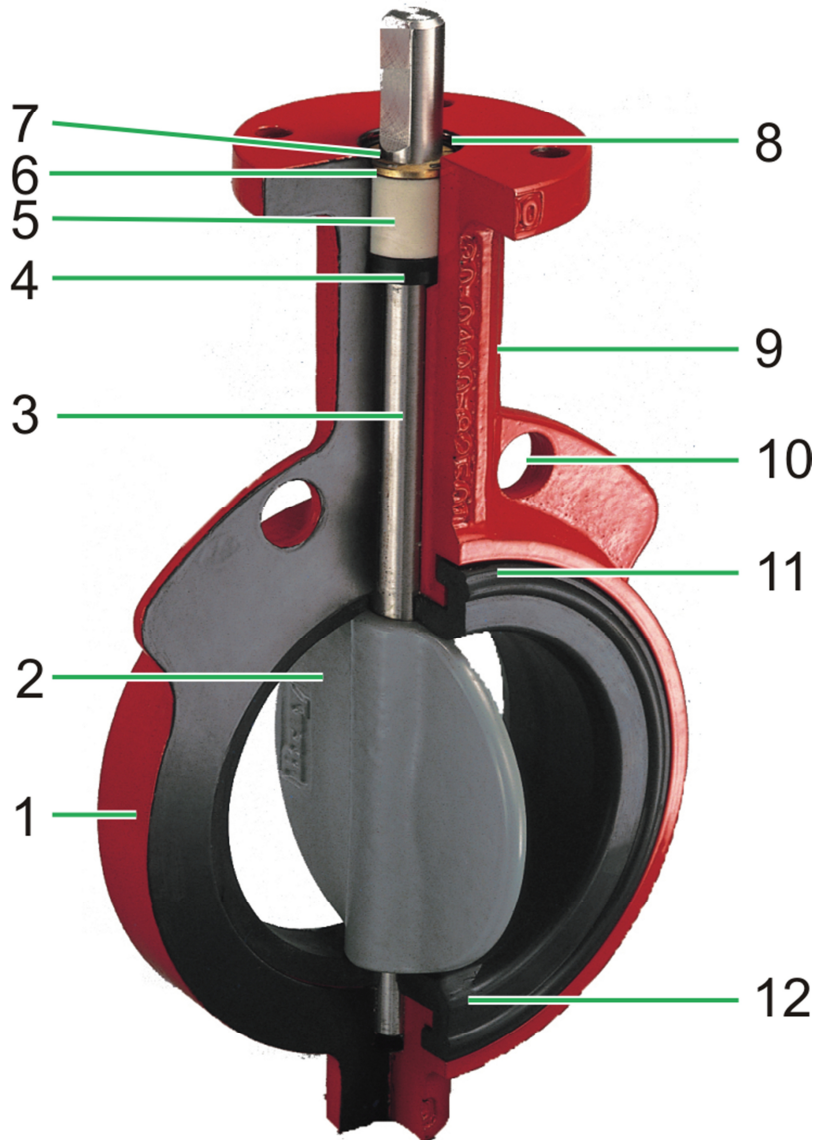

Fig. 1 Example Butterfly Valve Sectioned

Bray's tongue and groove seat design (11 see Table 1 also) lowers torque and provides complete isolation of flowing media from the body. The seat also features a molded O-ring which eliminates the use of flange gaskets.

The lug type valve body (1) is polyester coated for excellent corrosion resistance.

Primary and secondary seals (12). These seals prevent line media from coming in contact with the stem or body. Primary seal is achieved by an interference fit of the molded seat flat with the disc hub. Secondary seal is created because the stem diameter is greater than the diameter of the seat stem hole.

The valve disc (2) is coated with Nylon 11 thermoplastic material (a mineral based material). This ensures an excellent durability against corrosion. This is documented in a 2000 hour salt spray test and over a six year long continuous sea water test. No signs of corrosion were found.

Technical description

The surface is:

- Unsusceptible to impact and abrasion resistant (low friction coefficient).
- Resistant to ultra-violet radiation.
- Resistant to fungi

The valve neck (9) makes a simple insulation of the pipe and valve body possible. The flange fitting holes (10) simplify fitting and ensure proper centering in the pipe system.

Table 1 *Technical specifications*

	DN50 to DN500
Fluids	Hot and cold water with 50% Glycol vol. max. Well water, saltwater.
Body Nominal PN	16 bar
Close of pressure	1200kPa DN50 up to DN300 1000kPa DN350 up to DN500 models with undercut disc 350kPA
Dead-End Service	520kPa DN50 up to DN300 340kPa DN350 up to DN500
Fluid temperature	-29°C to 121°C
Transport/storage temp.	-20°C to 80°C, dry and dust free, not exposed to strong sunlight.
Pipe connection DN50 to DN500	Flange PN16 (as per ISO 7005-2)
Top flange	as per ISO 5211
Face flanges	as per ISO 7005-2 and EN1092-2
Leak rate	Gas tight leak rate A (EN12266-1)
Turning angle	Angle 90°
Basic standard	EN 593 (DIN 3354)
Face-to-face	As per ISO 5752, EN 558-1 row 20 (DIN 3202 part 3K1)
Fitting position	horizontal and vertical corresponding to the valve stem
Service	Very low maintenance
Fluid speed max.	Liquids:4m/sec. recommended (max.9m/sec.) air: 54m/sec.
Material:	
Body (1)	ASTM A-395 Grade 60-40-18 ≈ GGG 40
Stem (3)	ASTM A-582 Type 416 ≈1.4405
Primary & secondary seal and seat(11&12)	EPDM
Disc (2)	ASTM A-536 grade 65-42-12 ≈ GGG40 with Nylon 11 coating
Stem seal (4)	Buna-N strengthened
Stem bushing (5)	Polyacetal
Locking ring (6)	Galvanized steel spring
Shaft lock(7)	CrNiMo- steel
Spacer (8)	CrNiMo- steel

Technical description

Table 2 *Specification overview*

Model	Nominal size	K _{vs} -Value	Weight kg	Max. Δp (kPa) Close-off pressure	Top flange ISO 5211
BL10050	050	124	3	1200	F 07
BL10065	065	243	3.5	1200	F 07
BL10080	080	397	4	1200	F 07
BL10100	100	723	7	1200	F 07
BL11100	100	723	7	350	F 07
BL10125	125	1.083	9	1200	F 07
BL11125	125	1.083	9	350	F 07
BL10150	150	1.591	10	1200	F 07
BL11150	150	1.591	10	350	F 07
BL10200	200	2.852	19	1200	F 12
BL11200	200	2.852	19	350	F 12
BL10250	250	4.670	30	1200	F 12
BL11250	250	4.670	30	350	F 12
BL10300	300	6.946	40	1200	F 12
BL11300	300	6.946	40	350	F 12
BL10350	350	9.063	52	1200	F 12
BL11350	350	9.063	52	350	F 12
BL10400	400	12.044	75	1000	F 12
BL11400	400	12.044	75	350	F 12
BL10450	450	14.804	103	1000	F 16
BL11450	450	14.804	103	350	F 16
BL10500	500	19.212	118	1000	F 16
BL11500	500	19.212	118	350	F 16

3.1 Manually operated positioning with lever and manual gearbox

Bray offers hand levers (DN50 to DN300) and manual operation with gearbox (DN50 to DN500) to manually operate and position the valve disc. The hand levers have a setting of 10 ratchet adjustments. The self-locking gears have a smooth operation

A sudden closing of the valve, through the system, is to be avoided (danger from water hammer).

Table 3 Manually operated combination

Model	Max. Δp (kPa) Close-off pressure	K_{vs} -Value [m ³ /h]	Lever	Manual gearbox
Valve				
BL10050	1200	124	BV002M	BV001G
BL10065	1200	243	BV002M	BV001G
BL10080	1200	397	BV002M	BV001G
BL10100	1200	723	BV003M	BV001G
BL11100	350	723	BV003M	BV001G
BL10125	1200	1.083	BV004M	BV001G
BL11125	350	1.083	BV004M	BV001G
BL10150	1200	1.591	BV004M	BV001G
BL11150	350	1.591	BV004M	BV001G
BL10200	1200	2.852	BV005M	BV002G
BL11200	350	2.852	BV005M	BV002G
BL10250	1200	4.670	BV006M	BV003G
BL11250	350	4.670	BV006M	BV003G
BL10300	1200	6.946	BV006M	BV003G
BL11300	350	6.946	BV006M	BV003G
BL10350	1000	9.063		BV004G
BL11350	350	9.063		BV004G
BL10400	1000	12.044		BV004G
BL11400	350	12.044		BV004G
BL10450	1000	14.804		BV005G
BL11450	350	14.804		BV005G
BL10500	1000	19.212		BV005G
BL11500	350	19.212		BV005G

To order an already fitted combination simply add the module, for example

BL10065/BV002M

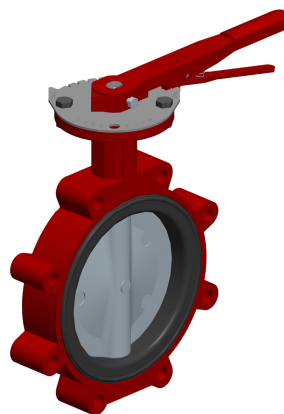

BL10300/BV003G

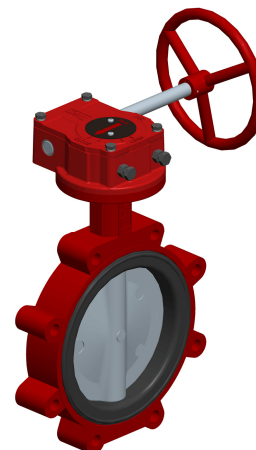

Technical description

3.2 Combination with the S70M electric actuator

Bray offers the S70M electric rotary actuator series for use with the BL10000 butterfly valve from size DN 50 for exact positioning and tight closing. The actuators are combined with controllers that have proportional and switchable 2-point and 3-point output for safe operation of the butterfly valve. The actuators feature the following:

- 24V AC and 230V AC 2-point, floating or modulating models
- Output torque from 68 Nm to 2034 Nm
- Hand wheel for manual operation always present
- 2 auxiliary switches as standard
- Clamp connection
- Direct fit to the BL10000 butterfly valve
- Optical position display
- Suitable for industrial environment (IP65)
- Very low maintenance
- Turning angle reduction through a positioning switch (preset at 90°) and intelligent turning angle adapter incl. adapted feedback signal
- Self-regulating heater to prevent condensation buildup within the actuator (optional)
- Adjustable positioning speed, corresponding to the in-situ application (modulation model)
- Response sensitivity adjustable in-situ (modulation model)



Technical description

Table 4 S70M with 230V operating

			Actuator model	S70M2300061SVH	S70M2300061	S70M2300201SVH	S70M2300201	S70M2300651SVH	S70M2300651	S70M2301306SVH	S70M2301306	S70M2301806SVH	S70M2301806
Torque Nm				68	68	226	226	735	735	1470	1470	2034	2034
Voltage AC				230	230	230	230	230	230	230	230	230	230
Proportional				√		√		√		√		√	
Input 0-10V; 0-5V; 2-10V; 4-20mA				√		√		√		√		√	
Output 0-10V; 0-5V; 4-20mA				√		√		√		√		√	
2 Point/floating					√		√		√		√		√
2 auxiliary switches				√									
Heater standard				√		√		√		√		√	
Running time in s				36	36	36	36	36	36	132	132	132	132
Adjustable running time				√		√		√		√		√	
Model	Nominal size	K _{vs} value	Max. Δp (kPa)										
BL10050	050	124	1200	√	√								
BL10065	065	243	1200	√	√								
BL10080	080	397	1200	√	√								
BL10100	100	723	1200	√	√								
BL11100	100	723	350	√	√								
BL10125	125	1.083	1200	√	√								
BL11125	125	1.083	350	√	√								
BL10150	150	1.591	1200	√	√								
BL11150	150	1.591	350	√	√								
BL10200	200	2.852	1200			√	√						
BL11200	200	2.852	350			√	√						
BL10250	250	4.670	1200					√	√				
BL11250	250	4.670	350			√	√						
BL10300	300	6.946	1200					√	√				
BL11300	300	6.946	350					√	√				
BL10350	350	9.063	1000					√	√				
BL11350	350	9.063	350					√	√				
BL10400	400	12.044	1000							√	√		
BL11400	400	12.004	350					√	√				
BL10450	450	14.804	1000							√	√		
BL11450	450	14.804	350					√	√				
BL10500	500	19.212	1000									√	√
BL11500	500	19.212	350					√	√				

Note: All proportional models (SVH) include a heater as standard

Technical description

Table 5 S70M with 24V operating

			Actuator model					
			S70M240060SVH	S70M240060	S70M240200SVH	S70M240200	S70M240500SVH	S70M240500
Torque Nm			68	68	226	226	565	565
Voltage AC			24	24	24	24	24	24
Proportional			√		√		√	
Input 0-10V;0-5V 2-10V; 4...20mA			√		√		√	
Output: 0-10V;0-5V 4...20mA			√		√		√	
2 Point/floating				√		√		√
2 auxiliary switches			√					
Heater standard			√		√		√	
Running time in s			60	60	60	60	60	60
Adjustable running time			√		√		√	
Model	Nominal size	K _{vs} value	Max. Δp (kPa)					
BL10050	050	124	1200	√	√			
BL10065	065	243	1200	√	√			
BL10080	080	397	1200	√	√			
BL10100	100	723	1200	√	√			
BL11100	100	723	350	√	√			
BL10125	125	1.083	1200	√	√			
BL11125	125	1.083	350	√	√			
BL10150	150	1.591	1200	√	√			
BL11150	150	1.591	350	√	√			
BL10200	200	2.852	1200			√	√	
BL11200	200	2.852	350			√	√	
BL10250	250	4.670	1200					√
BL11250	250	4.670	350			√	√	
BL10300	300	6.946	1200					√
BL11300	300	6.946	350					√
BL10350	350	9.063	1000					
BL11350	350	9.063	350					√
BL10400	400	12.044	1000					
BL11400	400	12.004	350					√
BL10450	450	14.804	1000					
BL11450	450	14.804	350					√
BL10500	500	19.212	1000					
BL11500	500	19.212	350					

To order an already fitted combination simply add the module, for example BL10200/S70M240200

You can also order with a built-in self-regulating heater that prevents condensation within the actuator. Just add an "H" to the actuator order No. for example: BL10200/S70M240200H

3.2.1 Electrical OEM standard damper actuators with and without spring return.

Bray has prepared linkage-kits for standard electric damper actuators with and without spring return.

Dimension drawings come later in this document. Customized fittings are possible if required.

As a first point of reference use the table below to work out the required minimum torque that is determined by the momentary seating/unseating torque.

Please contact us for the possible combinations with your OEM actuators

Table 6 Torque requirements

Model	Nominal size	Seating/unseating torque (Nm)*
BL10050	050	14
BL10065	065	17
BL10080	080	20
BL10100	100	42
BL11100	100	20
BL10125	125	53
BL11125	125	35
BL10150	150	64
BL11150	150	52
BL10200	200	138
BL11200	200	64
BL10250	250	298
BL11250	250	127
BL10300	300	467
BL11300	300	234
BL10350	350	656
BL11350	350	339
BL10400	400	915
BL11400	400	438
BL10450	450	1205
BL11450	450	541
BL10500	500	1576
BL11500	500	705

*Valid for the application case A: Water temperature range 0° to 80°C. Valve must be cycled once weekly.

Technical description

3.2.2 Function

The butterfly valve is used as a stop cock or a control valve.

Manual operation is possible through a hand lever or manual gearbox.

The S70 is available as an industrial standard direct-fit electric none spring return actuator. When using 3rd party standardized electric damper-actuators with and without spring return, Bray is ready to advise you.

3.2.3 Project planning and mounting instruction

The valve is bolted between two flanges. During fitting, the butterfly valve must be opened in accordance with the mounting instructions.

The seat is so constructed that no additional seals or gaskets are necessary when the butterfly valve is fitted between the pipe flanges.

Flow can be Bi-directional.

3.2.4 Additional operational information

- Face-to-face dimensions in accordance with ISO 5752, EN 558 row 20
DIN 3202 Part 3 K1
- Parts in contact with fluids are the valve disc and seat.
- Actuator top flange in accordance with ISO 5211
- Fitted flange in accordance with EN 1092-2

3.2.5 Pressure Equipment Directive – PED

The valves are manufactured in accordance with conformity assessment procedure:

Annex III, Module H of the Pressure Equipment Directive 97/23/EC, and Schedule 4, Module H of the Pressure Equipment Regulations 1999 and conforms to the requirements for the products.

Certificate No: 0038/PED/HOU/ECD1420021/1

Original Approval: 29. April 2014

Certificate Expiry: 28. April 2017

LRV Notified Body Number 0038

Kvs/flow diagram and flow characteristic diagrams

4 K_{vs} /flow diagram and flow characteristic diagrams

The following table and diagram give the flow volume (K_{vs} value) at a fully open valve and a Δp of 100kPa across the valve at a water temperature between 5°C and 30°C as well as varying differential pressures across the valve.

Note: During configuration the maximum flow speed of 4 m/s (water) is recommended with regard to, for example low noise.

Table 7 K_{vs} /flow

DN mm	K_{vs} m^3/h	Flow in m^3/h				
		Δp kPa	Δp kPa	Δp kPa	Δp kPa	Δp kPa
		0.01	0.1	1	2	3
50	124	1.24	3.9	12	17.5	21.5
65	243	2.43	7.7	24	34	42
80	397	4.0	13	40	56	69
100	723	7.2	23	72	102	125
125	1083	11	34	108	153	188
150	1591	16	50	159	225	276
200	2852	29	90	285	403	494
250	4670	47	148	467	660	809
300	6946	69	220	695	982	1203
350	9063	91	287	906	1282	1570
400	12044	120	381	1204	1703	2086
450	14804	148	468	1480	2094	2564
500	19212	192	608	1921	2717	3328

Kvs/flow diagram and flow characteristic diagrams

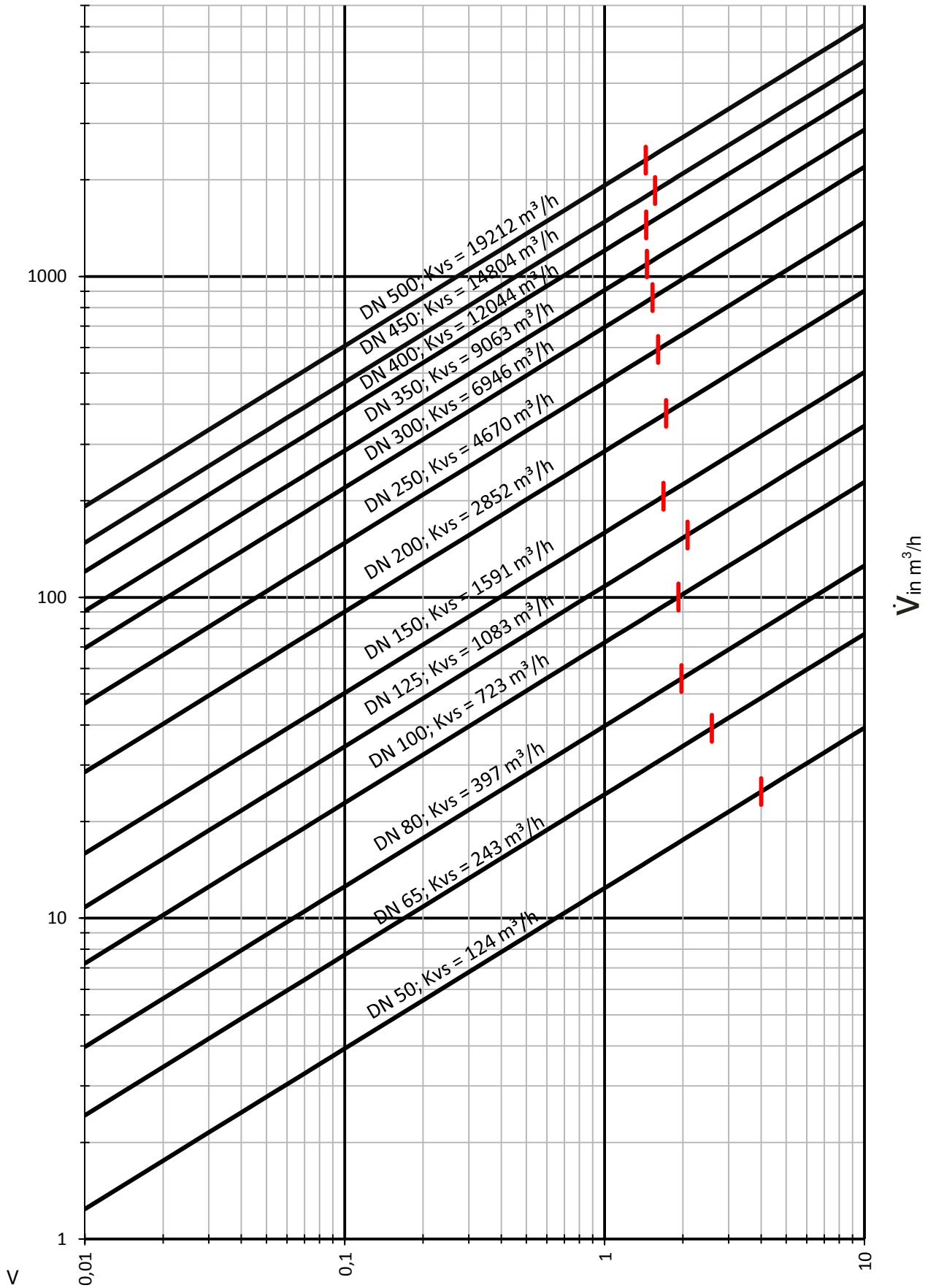

Fig. 2 Pressure drop Δp in kPa

Kvs/flow diagram and flow characteristic diagrams

The BL10000 butterfly valve characteristic curve is a modified equal percent flow characteristic as per VDI 2176. At a disc angle of 70° the K_v value is 55% to 60% of the K_{vs} value. Recommended range for modulating control up to 70%.

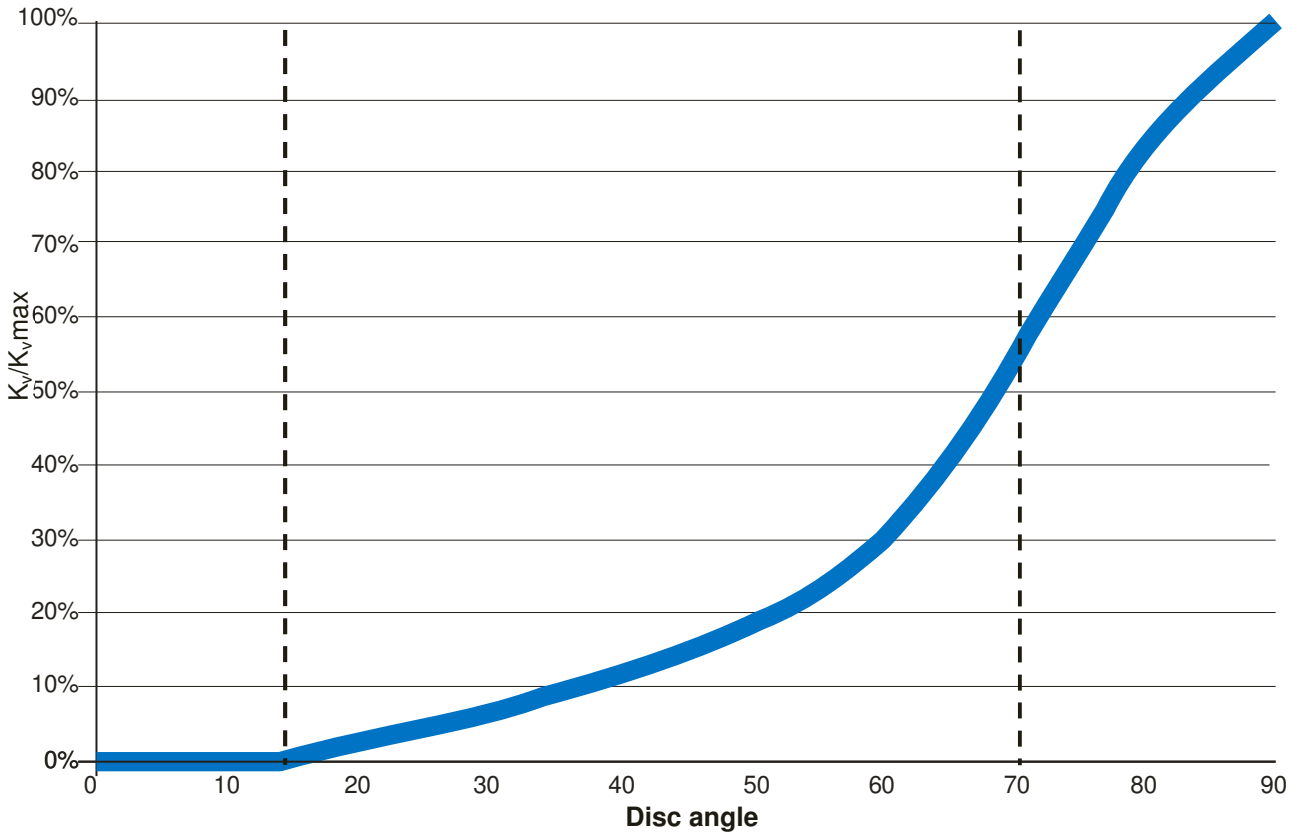

Fig. 3 BV 10000, flow curve, schematic diagram, DN50 up to DN 500

Table 8 Valves: DN 100 to DN 150 – K_v values

Valves: DN 50 to DN 80 – K_v values

disc angle°	DN 50 m ³ /h	DN 50	DN 65 m ³ /h	DN 65	DN 80 m ³ /h	DN 80
0	0	0%	0	0%	0	0%
10	0.9	0.7%	1.3	0.5%	1.7	0.4%
20	6	5%	10	4%	13	3%
30	14	11%	21	9%	30	8%
40	23	19%	37	15%	53	13%
50	37	30%	58	24%	83	21%
60	53	43%	92	38%	123	31%
70	72	58%	140	58%	230	58%
80	98	79%	192	79%	313	79%
90	124	100%	243	100%	397	100%

Kvs/flow diagram and flow characteristic diagrams

Table 9 Valves: DN 100 to DN 150 – K_v values

disc angle°	DN 100 m ³ /h	DN 100	DN 125 m ³ /h	DN 125	DN 150 m ³ /h	DN 150
0	0	0%	0	0%	0	0%
10	2.6	0.36%	4.3	0.4%	5.2	0.33%
20	23	3%	37	3%	48	3%
30	53	7%	84	8%	111	7%
40	94	13%	146	13%	194	12%
50	147	20%	231	21%	304	19%
60	236	33%	368	34%	488	31%
70	427	59%	667	62%	882	55%
80	603	83%	986	91%	1326	83%
90	723	100%	1083	100%	1591	100%

Table 10 Valves: DN 200 to DN 300 – K_v values

disc angle°	DN 200 m ³ /h	DN 200	DN 250 m ³ /h	DN 250	DN 300 m ³ /h	DN 300
0	0	0%	0	0%	0	0%
10	10.3	0.36%	16.3	0.35%	23.3	0.34%
20	88	3%	139	3%	202	3%
30	207	7%	329	7%	477	7%
40	362	13%	574	12%	864	12%
50	585	21%	925	20%	1371	20%
60	876	31%	1471	31%	2204	32%
70	1601	56%	2535	54%	3778	54%
80	2444	86%	3892	83%	5789	83%
90	2852	100%	4670	100%	6946	100%

Kvs/flow diagram and flow characteristic diagrams

Table 11 Valves: DN 350 to DN 500 – K_v values

disc angle°	DN 350 m ³ /h	DN 350	DN 400 m ³ /h	DN 400	DN 450 m ³ /h	DN 450	DN 500 m ³ /h	DN 500
0	0	0%	0	0%	0	0%	0	0%
10	29.2	0.32%	38.7	0.32%	49.9	0.34%	61.9	0.32%
20	257	3%	341	3%	436	3%	544	3%
30	650	7%	861	7%	1102	7%	1372	7%
40	1135	13%	1504	12%	1924	13%	2326	12%
50	1848	20%	2448	20%	3133	21%	3901	20%
60	2910	32%	3855	32%	4933	33%	6144	32%
70	5108	56%	6766	56%	8656	58%	10780	56%
80	7632	84%	10115	84%	12467	84%	16178	84%
90	9063	100%	12044	100%	14804	100%	19212	100%

The K_v readings give the water flow in m³/h at temperatures between 5°C and 30°C and a pressure loss of 1 bar (100 kPa) at the corresponding orifice angle.

Please note that the recommended maximum water flow speed of 4 m/s and air flow speed of 54 m/s are not to be exceeded.

Drawings and dimension tables [mm]

5 Drawings and dimension tables [mm]

5.1 BL10000 DN 50 to DN 300

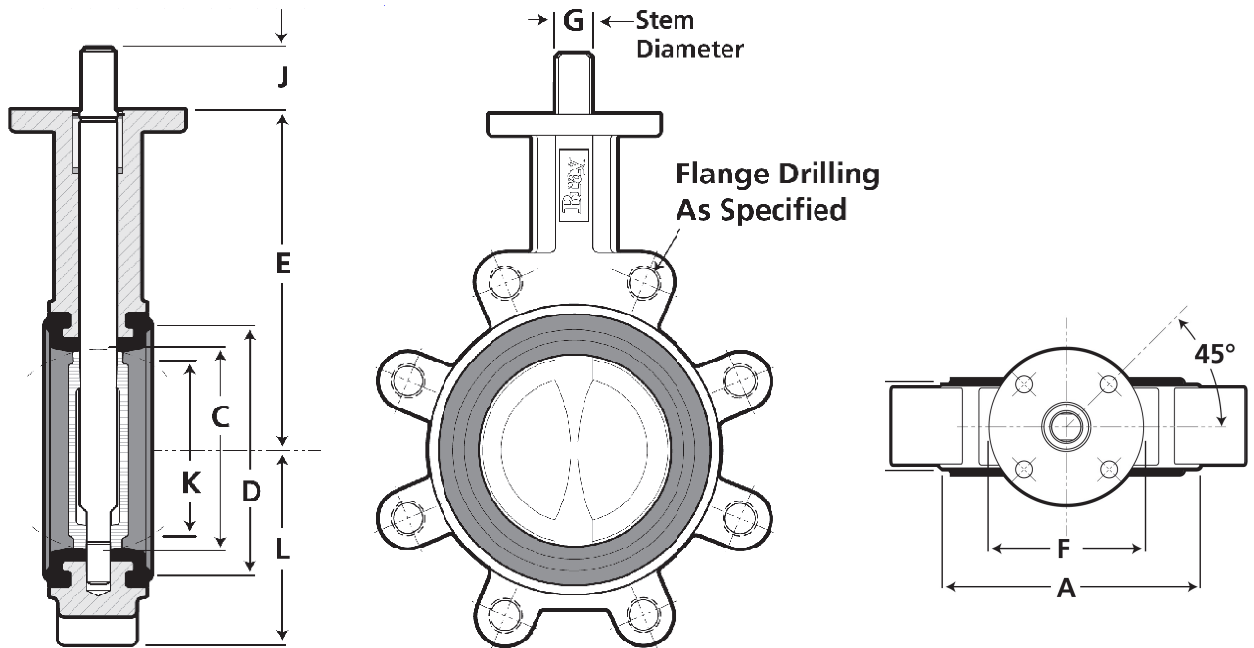

5.2 BL10000 DN 350 to DN 500

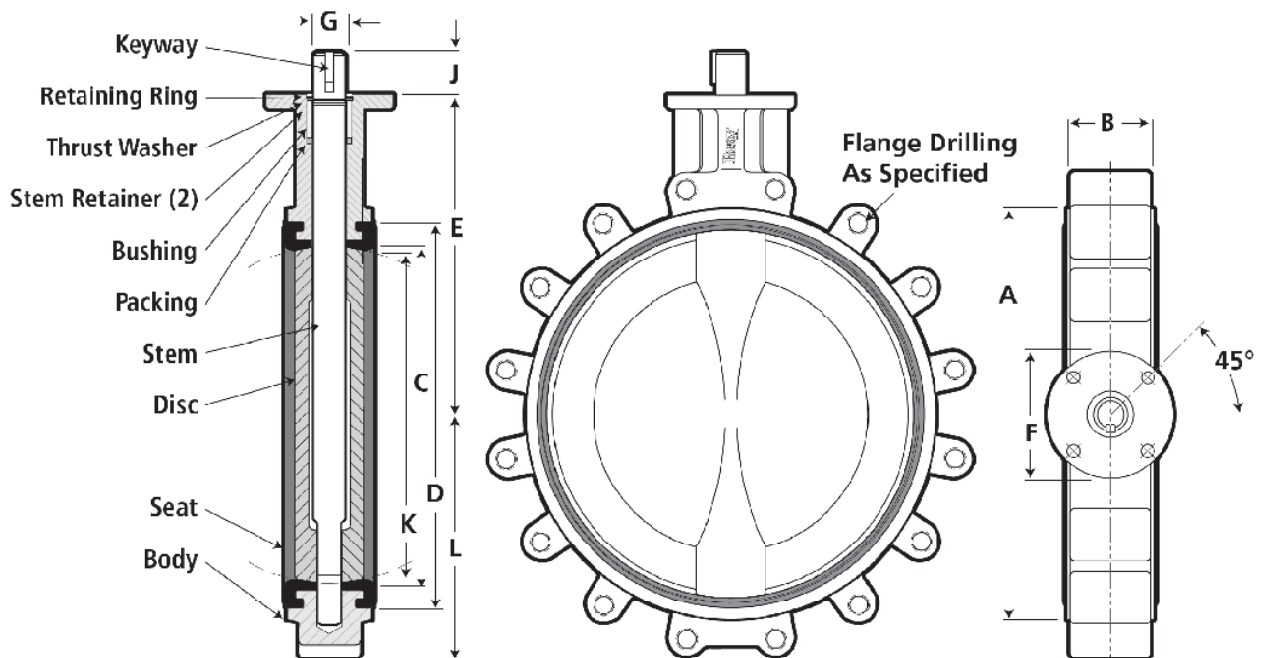

5.3 DN 50 to DN 500 dimension table

Table 12 DN 50 to DN 500 dimensions

Size	A	B	C	D	E	F	G	H*	J	K	L
DN	In mm										
50	94	43	51	72	140	90	14	10	32	34	58
65	106	46	64	85	152	90	14	10	32	49	65
80	124	46	76	102	159	90	14	10	32	65	71
100	154	52	102	131	178	90	16	11	32	91	104
125	181	56	127	156	190	90	19	13	32	118	117
150	206	56	146	178	203	90	19	13	32	138	129
200	267	60	197	240	241	150	22	16	32	189	154
250	324	68	248	291	273	150	30	22	51	242	195
300	378	76	298	342	311	150	30	22	51	291	229
350	433	76	337	388	346	150	35	10x10	51	331	252
400	488	102	387	442	375	150	35	10x10	51	377	287
450	536	108	438	495	406	210	50	12x10	64	428	309
500	591	127	489	548	438	210	50	12x10	64	476	358

*DN350 up to DN500 = Key size

Table 13 DN 50 to DN 500 dimensions

Size	Top plate			Spindle		PN 16		Weight
	F	BC	Hole Diameter	G	H*	LK	Bolt	
DN	mm			mm		mm	Metric	kg
50	90	70	4x10	14	10	125	4xM16	3
65	90	70	4x10	14	10	145	4xM16	3.5
80	90	70	4x10	14	10	160	8xM16	4
100	90	70	4x10	16	11	180	8xM16	7
125	90	70	4x10	19	13	210	8xM16	9
150	90	70	4x10	19	13	240	8xM20	10
200	150	125	4x14	22	16	295	12xM20	19
250	150	125	4x14	30	22	355	12xM24	30
300	150	125	4x14	30	22	410	12xM24	40
350	150	125	4x14	35	10X10	470	16xM24	52
400	150	125	4x14	35	10X10	525	16xM27	75
450	210	165	4x21	50	10X12	585	20xM27	103
500	210	165	4x21	50	10X12	650	20xM30	138

*DN350 up to DN500 = Key size

Drawings and dimension tables [mm]

5.4 BV00xM operating lever and BV00xG gear operator

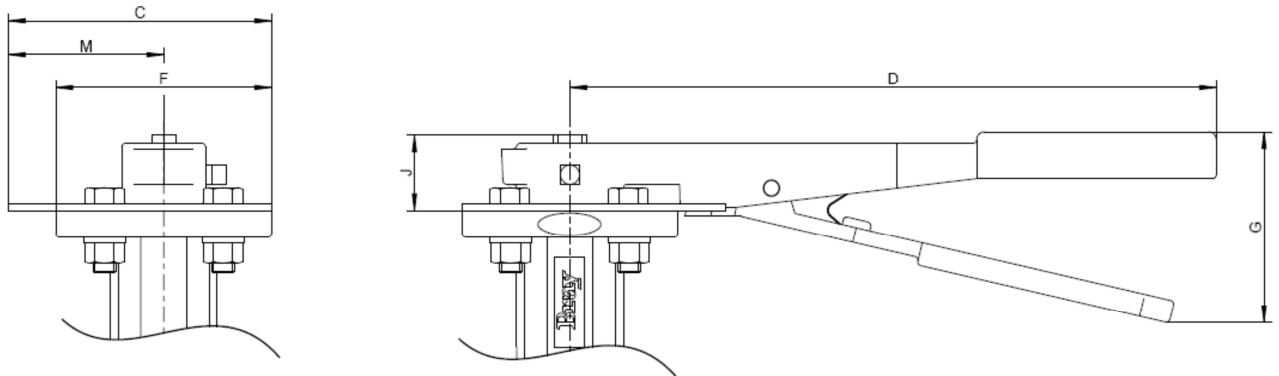

Fig. 4 Operating lever DN 50 to DN 300 with lockable notch plate

Table 14 BL10000 valve plus manual operating lever

Type	size	C	D	E	J	F	G	M
	DN	mm						
BV002M	50,65,80	110	270	140	32	90	80	65
BV003M	100	110	270	178	32	90	80	65
BV004M	125,150	110	270	203	32	90	80	65
BV005M	200	169	298	241	32	150	80	94
BV006M	250,300	169	298	273	51	150	80	94

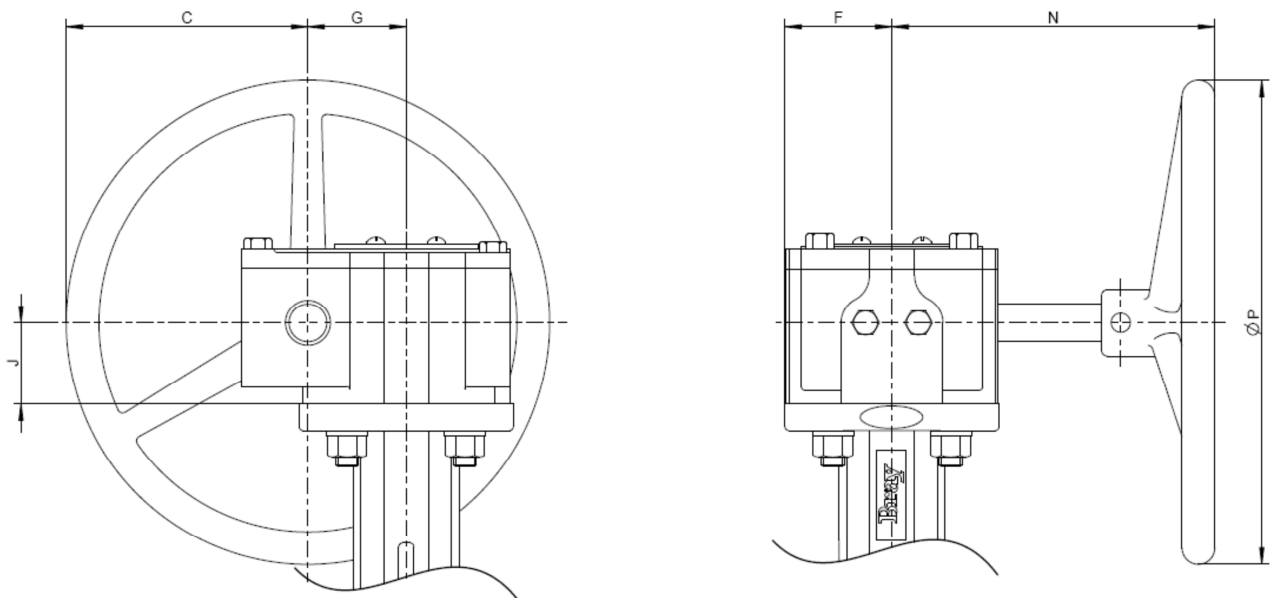

Fig. 5 Gear operator DN 50 to DN 500

Table 15 BL10000 valve plus gear operating device

Drawings and dimension tables [mm]

Type	Size	Gear operator	C	F	G	J	N	P
DN		mm						
BV001G	50 to 150	20:1	102	45	41	37	136	203
BV002G	200	30:1	102	75	67	32	190	203
BV003G	250,300	30:1	102	75	67	32	190	305
BV004G	350, 400	50:1	152	75	79	43	303	305
BV005G	450, 500	80:1	152	105	116	60	379	305

5.5 S70M Actuator 006, 020, 050, 065

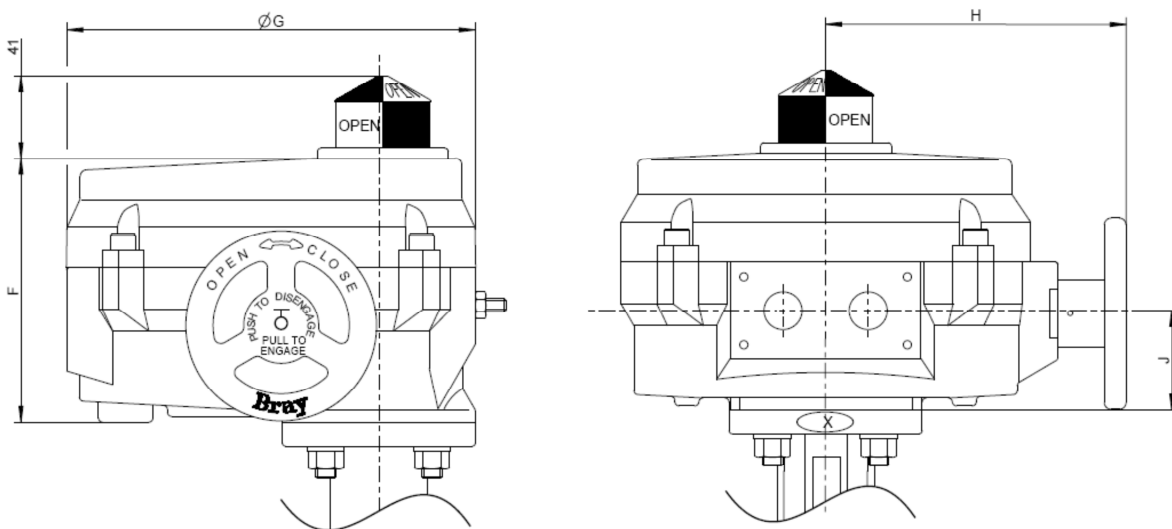

Fig. 6 S70M Actuator 006, 020, 050, 065

Drawings and dimension tables [mm]

5.6 S70M Actuator 130,180

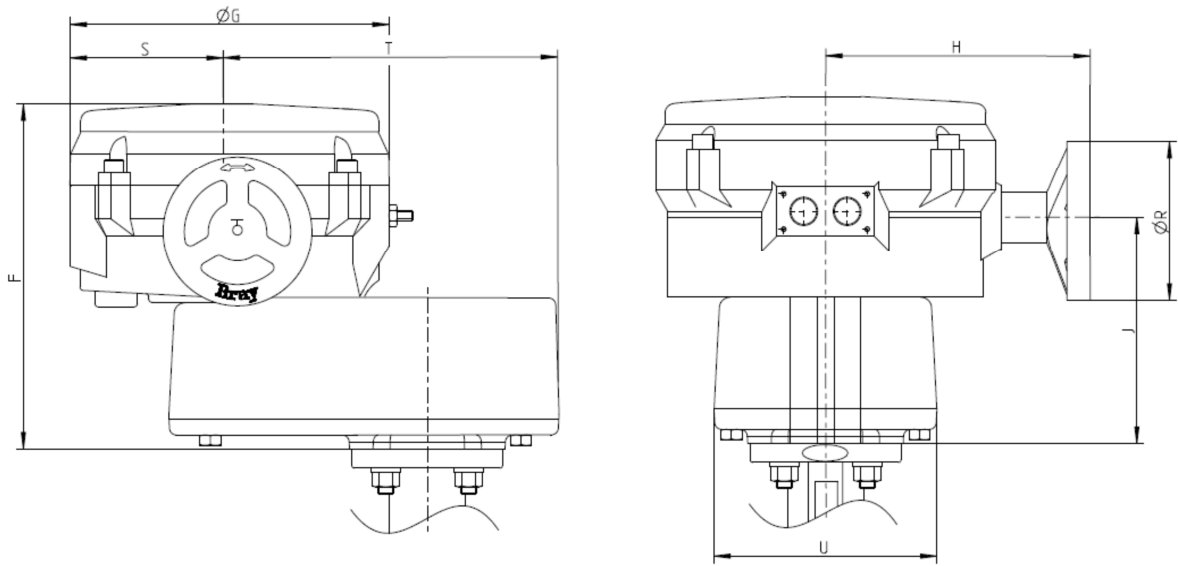

Fig. 7 S70M Actuator 130, 180

Table 16 BL10000 plus S70M dimensions

Actuator	F	G	H	J	S	T	R	U	Top flange
Model	mm								
S70M_006_	130	191	142	48	-	-	89	-	F07
S70M_020_	165	257	198	64	-	-	203	-	F07/F12
S70M_050_	183	307	241	74	-	-	305	-	F12/F16
S70M_065_									
S70M_130_	317	307	241	206	155	323	305	203	F12/F16
S70M_180_									

! Note:

Ensure there is adequate room for the valve package assembly to be fitted, operated and maintained in its pipe/system orientation and application.

5.7 RA Electric Rotary Actuator DN 50 up to DN 100

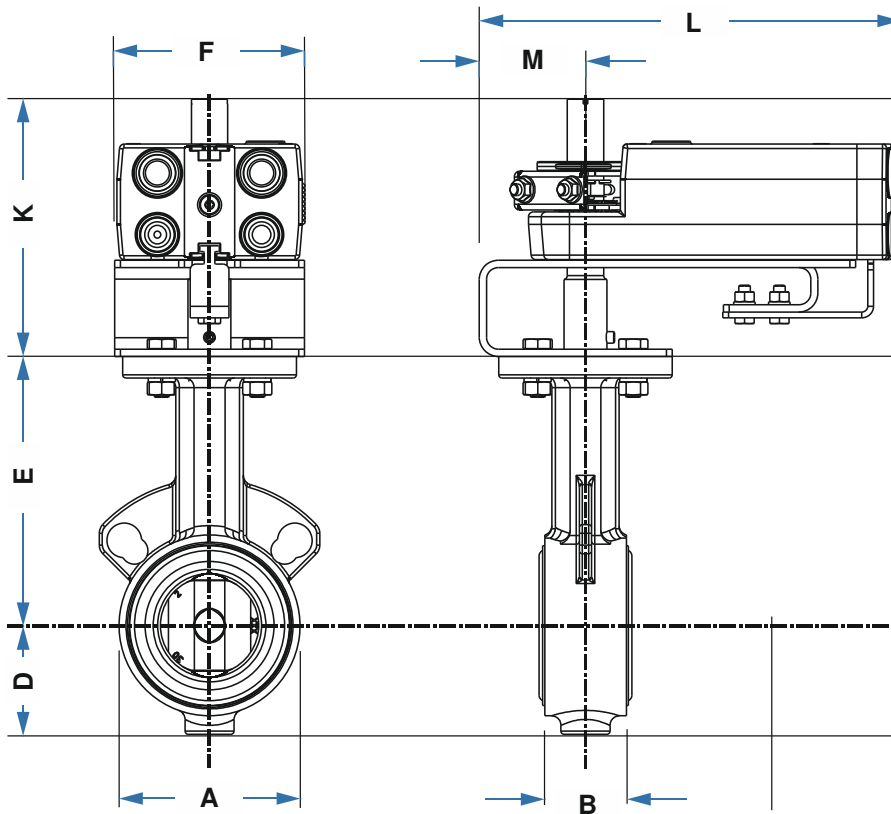

Fig. 8 RA Actuator DN50

Table 17 RA plus BL10000 DN 50 up to DN 100 Dimension

Size	Type	A	B	D	E	F	K	L	M
DN		mm							
50	BL10050	94	42	56	140	97	135	218	55
65	BL10065	106	45	63	152	97	135	218	55
80	BL10080	124	45	71	159	97	135	218	55
100	BL1x100	154	51	87	178	97	135	218	55

Drawings and dimension tables [mm]

5.8 RA Electric Rotary Actuator DN 125 up to DN 200

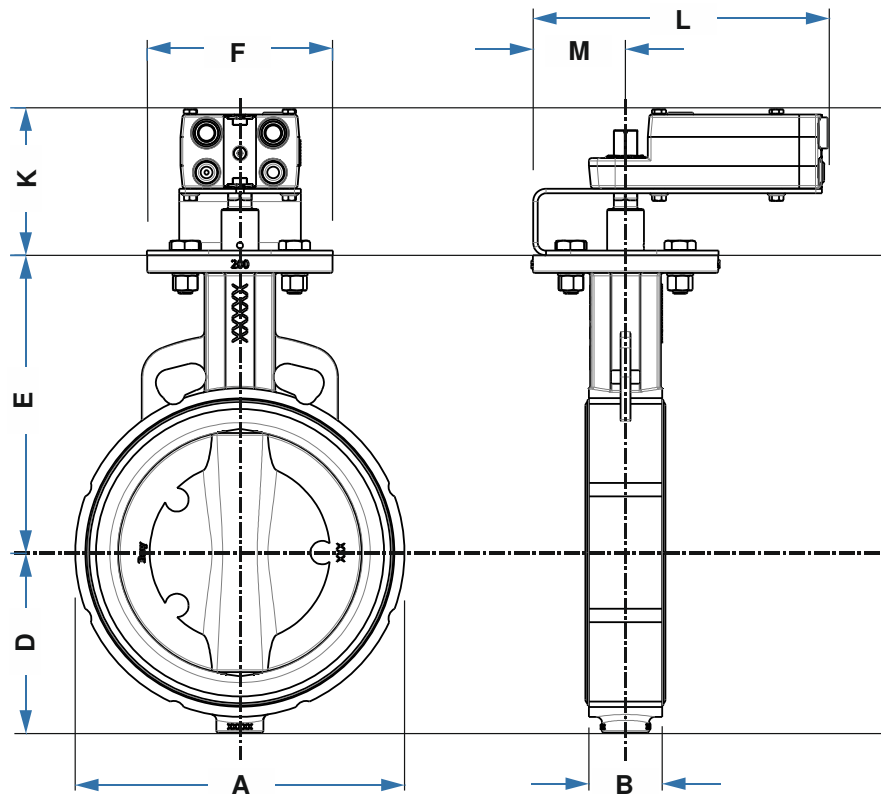

Fig. 9 RA Actuator DN200

Table 18 RA plus BL10000 DN 125 up to DN 200 Dimension

Size	Type	A	B	D	E	F	K	L	M
DN		mm							
125	BL1x125	179	55	102	190	151	118	238	74
150	BL1x150	206	55	115	203	151	118	238	74
200	BL11200	267	59	146	241	151	118	238	74

5.9 Universal OEM linkage kit

(Non-spring return and spring return)

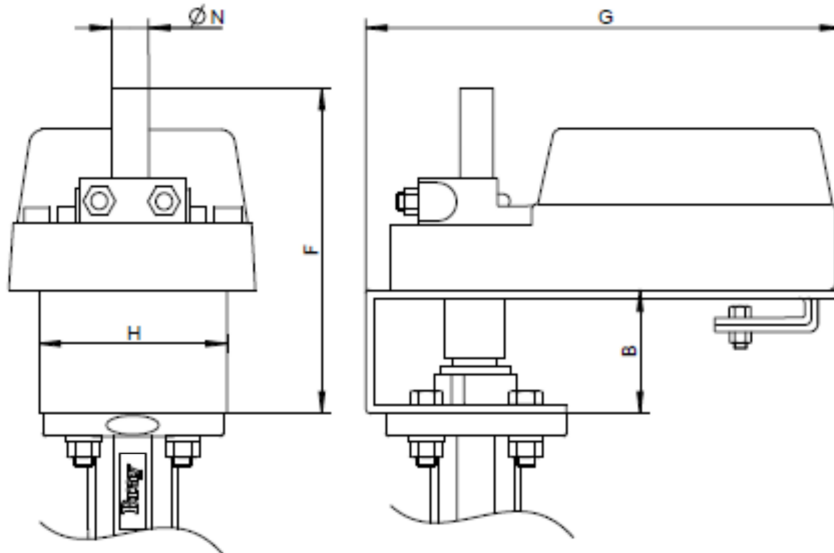

Fig. 10 Universal OEM linkage kit

Table 19 Universal OEM linkage kit assignment and dimensions

Type	size	ØN	H	F	B	G
	DN	mm	mm	mm	mm	mm
BVNSR2	50,65,80	19	97	135	50	195
BVNSR3	100	19	97	135	50	195
BVSR2	50,65,80	19	97	135	50	277
BVSR3	100	19	97	135	50	277

Note: The anti-rotation clip must be selected taking into account the make of the damper actuator. For advice when making your selection please contact your Bray Commercial partner.

General information

6 General information

6.1 General

All information contained in the Product bulletin is carefully verified. Bray Commercial assumes no responsibility for errors that might appear in this bulletin or for any damage to things or persons resulting from improper use of this bulletin or related products and software.

Bray Commercial reserves the right to change the contents of this bulletin as well as the specifications and features of related products and software without notice at any time.

For the purpose of this documentation, an 'operator' is someone who is familiar with the installation, startup, operation and maintenance of the system. The operator must have the following qualifications:

- Trained or authorized to energize/de-energize the system in accordance with established safety procedures.
- Trained and authorized in the proper care and use of protective equipment in accordance with established safety procedures.

6.2 Copyright protection

This product bulletin is protected by copyright laws and is for internal use only.

The reproduction and communication or application as well as the passing on to third parties of this product bulletin, including extracts, in any way, shape or form without the express written permission of the manufacturer is strictly forbidden.

6.3 Original product Series 31

The BL10000 Lug Butterfly Valve PN 16 is 100% identical with the Bray Valve Series 31 in the same sizes.

The item numbers of BL100000 matches direct to the item numbers of Bray Valves Series 31, Trim 36M with the Flange Drilling PN 16.