

ATLANTA

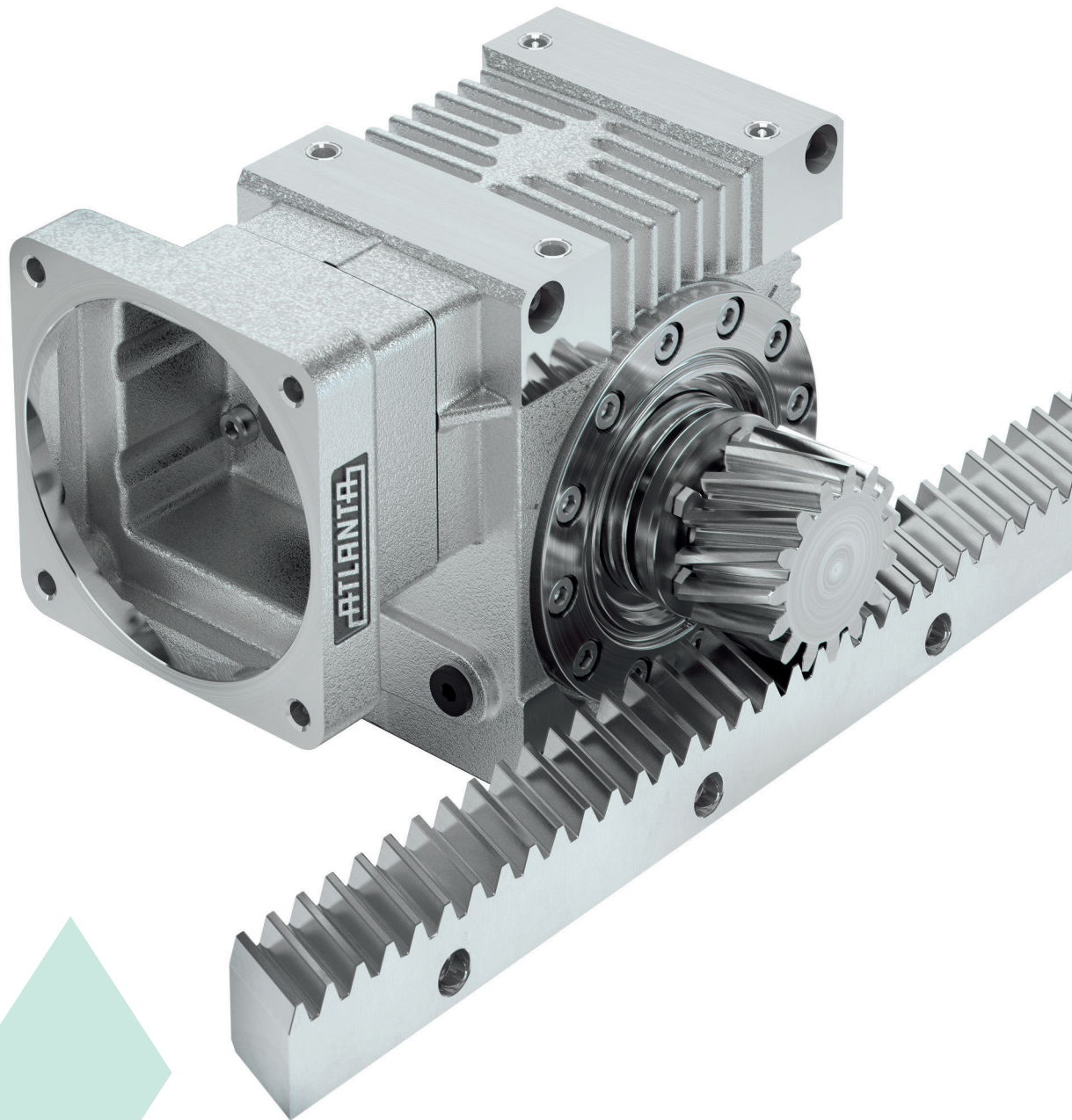

Servo Drive Systems
2019/2020

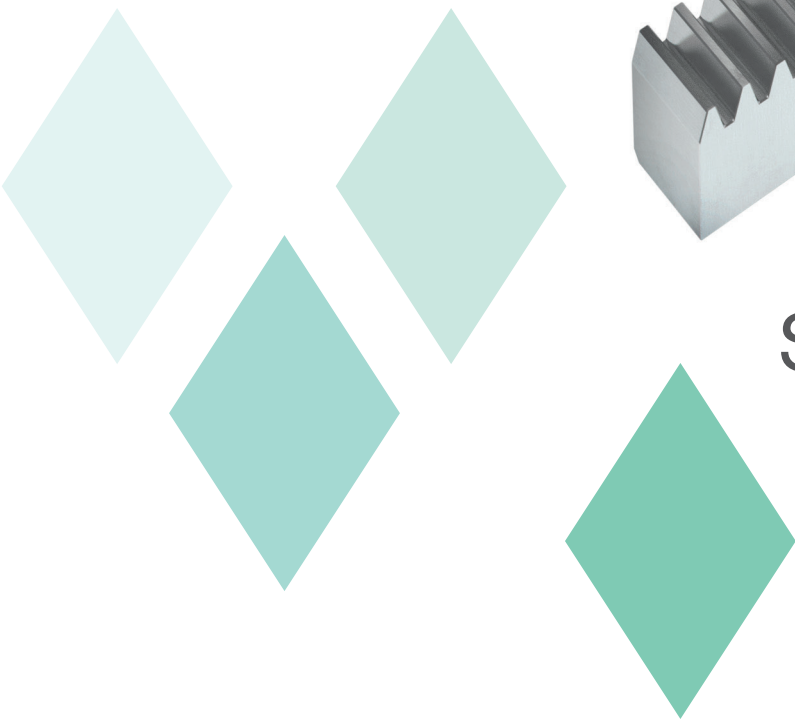



Servo-Drive Systems

ATLANTA Drive Systems Inc.

1775 Route 34, Unit D-10
Farmingdale, NJ 07727
USA

Telephone: (800) 505-1715

Fax: (732) 282-0450

E-Mail: info@atlantadrives.com

Internet: www.atlantadrives.com

Duplication – even by way of excerpts – is not allowed without our express permission. Dimensions and any other technical details given in this catalog are subject to alterations without notice and are completely without obligation on our part. All rights to make technical changes to the dimensions and the range of our standard programme are reserved.



ATLANTA

Tradition. Innovation. Progress.

ATLANTA Drive Systems has offered convincing high-quality power transmission solutions for more than 80 years. As a medium-sized company we have specialized in the development, construction and production of high quality drive systems.

ATLANTA customers are found in all areas of transmission engineering. The main focus however, lies in machine tool, woodworking machines, robotics and handlings, food machinery, packaging machines, boxing machines and special purpose machines.

We are market leaders in high quality racks and define market trends. All components of our products are produced exclusively in our three modern plants in Bietigheim-Bissingen, Germany.

We have 3 subsidiary companies and 23 agents in all industrialized countries to serve our customers all over the world.



ISO 9001 : 2008



ATLANTA

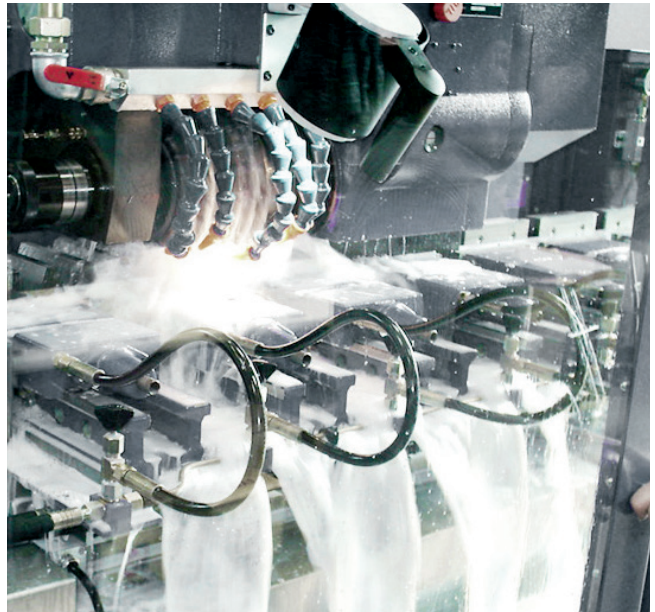
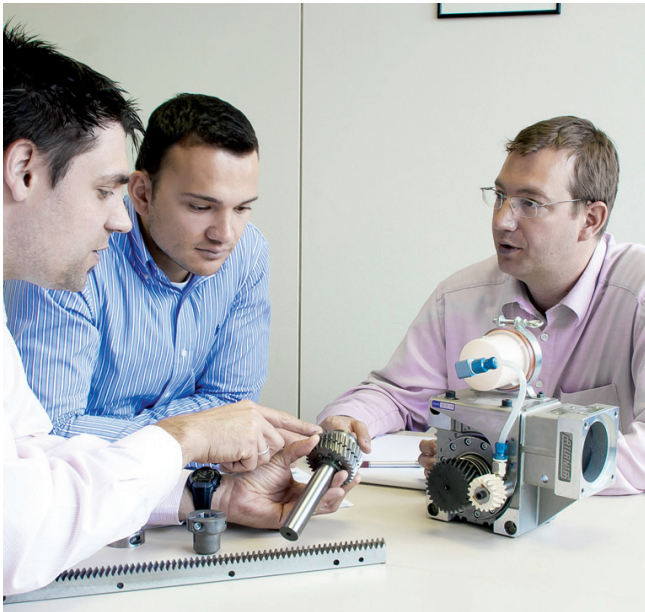

Mitglied / Member



Forschungsvereinigung
Antriebstechnik e.V.



Example High-Performance Gear Units

58 0 5 0 20

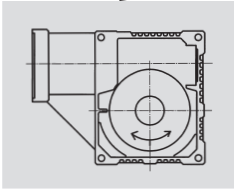

High-Performance Gear Units

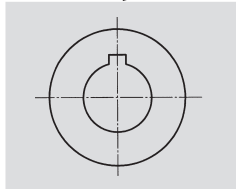

Keyway Design

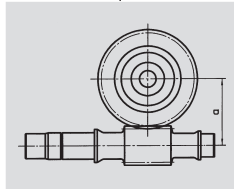

$a_o = 80$ mm
Center Distance

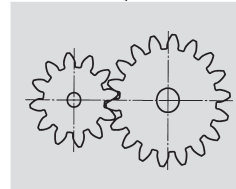

$i = 19.5$
Ratio

58 1 5 0 20

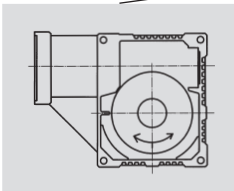

High-Performance Gear Units



Shrink-Disk Design

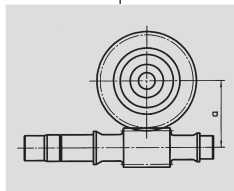

$a_o = 80$ mm
Center Distance

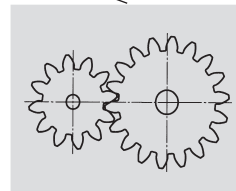

$i = 19.5$
Ratio

Example Racks- for Continuous Linking

28 2 0 100

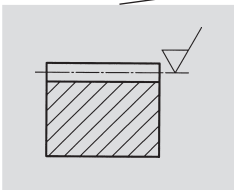

Design

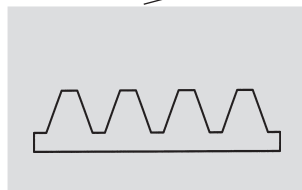

Module

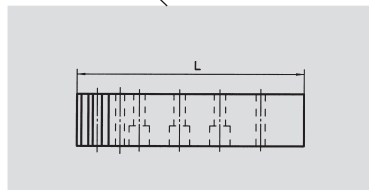

With Holes

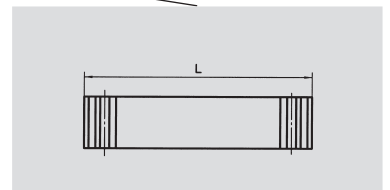

Rack Length



Servo Gearboxes	HT High-Torque Gear Units <1'		GA
	HP High-Performance Gear Units <2'		GB
	E Economy Gear Units <5'		GC
	B Basic Gear Units <12'		GD
	BG Servo-Bevel Gear Units <6'		GE
	Gear Units Calculation and Selection		GF
	Pinion and Output Drive Shafts		GG
	Shrink-Disk Clamping Sets		GH
	Mounting Guide for Servo-Gear-Boxes and Servo Motors		GI
Racks and Pinions	Helical Tooth System	$m = 1.5 - 12$	ZA
	Straight Tooth System	$m = 1 - 12$	ZB
	Integrated Racks for Guides	$m = 2 - 4$ $p = 5 - 13.33$	ZC
	Rack and Pinion Drive – Calculation and Selection		ZD
	Lubrication System		ZE
	Technical Aids		ZF
	Agents Germany/Worldwide		ZG



ATLANTA Servo Drive Systems: Setting Standards for Technological Leadership

The world's most extensive range of precision racks together with the complete family of servo gear units, provides an unmatched range of combinations to achieve the best solution to almost all possible applications.

HT-Servo

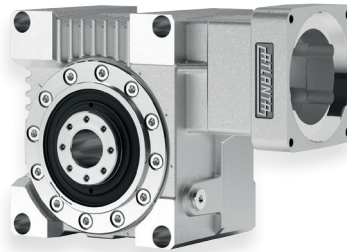

HP-Servo

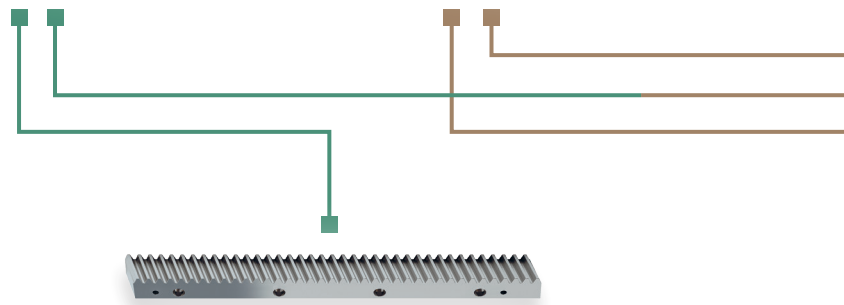
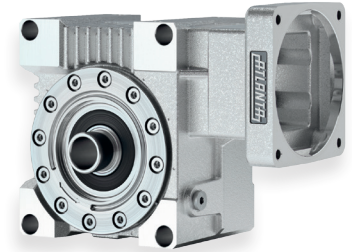

UHPR
Ultra High Precision Rack
Quality 3 + 5

For each application the right solution

- High-precision machine tools with electrical preload
- Machine tools, lifting axis, dual-pinion systems
Laser cutting machines



Photo: Vansichen Lineairtechniek Belgium

Driving and lifting axis of a robotic palletizer



E-Servo



BG-Servo

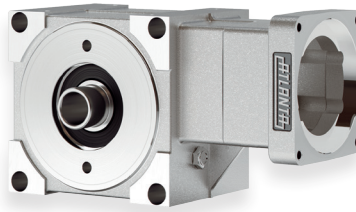

B-Servo

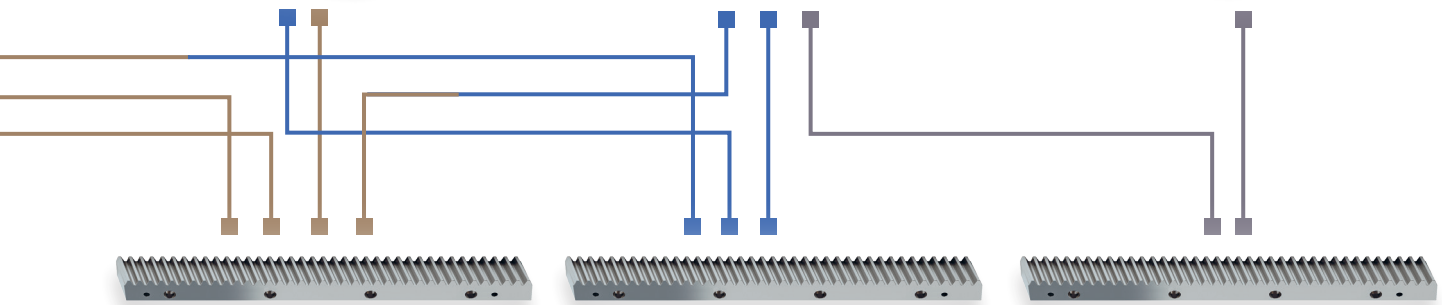
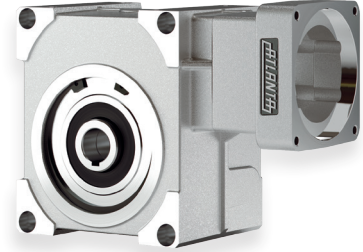

HPR
High Precision Rack
Quality 6 + 7

- Wood, plastic, composite aluminum working machines
- Machine tools, water cutting machines, tube bending systems, plasma cutting machines
- Woodworking machines, linear axis with high requirement for a smooth running

PR
Precision Rack
Quality 8

- Portals, handling, lifting axis
- Linear axis

BR
Basic Rack
Quality 9 + 10

- Linear axis with low load, feed units for adjustment
- Lifting axis, handling, welding robots



Photo: Vansichen Lineairtechniek Belgium

Linear axis with integrated lubrication system



HT High-Torque Gear Units

150% Output Torque
Backlash < 1 arcmin
Highest Stiffness

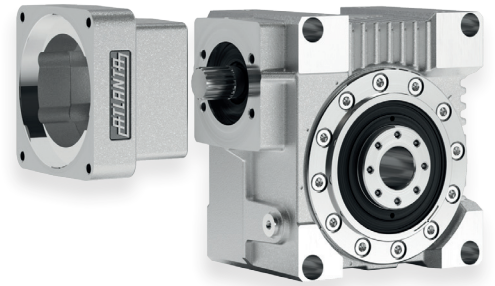

HP High-Performance Gear Units

100% Output Torque
Backlash < 2 arcmin
Highest Stiffness

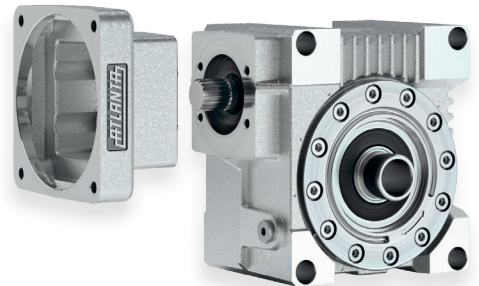

E Economy Gear Units

100% Output Torque
Backlash < 5 arcmin
Highest Stiffness



B Basic Gear Units

90% Output Torque
Backlash < 12 arcmin
High Stiffness

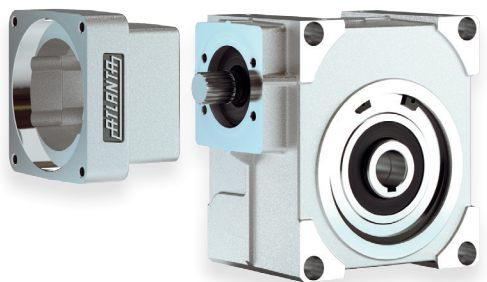

BG Servo-Bevel-Gear Units

100% Output Torque
Backlash < 6 arcmin
Highest Stiffness

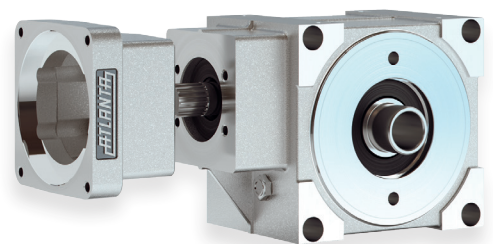

NEW • NEW • NEW • NEW • NEW • NEW

Food Grade

The New Servo Gear Units
available with food grade lubricant

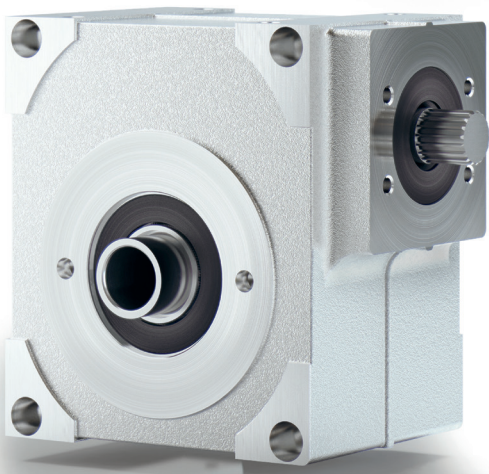

Picture apple: © atoss / Fotolia.com

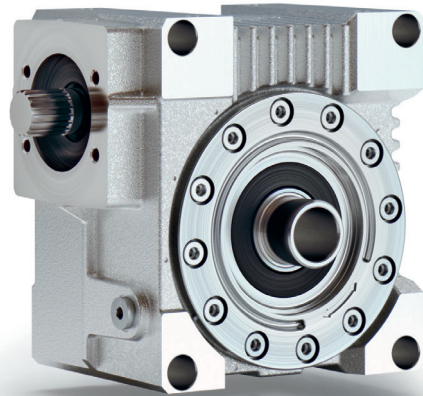

Manufacturing of machinery for the food industry must comply with a set of rules for general safety requirements, including cleaning and disinfection for hygiene. While drive technology is used in food processing machines and systems, it is not technically possible to eliminate 100% of the contact of food with lubricant, so food grade lubricants is a mandatory regulation in the food industry.

If needed, we supply our Servo Gear Units filled with food grade lubricant for use it in the food industry. Due of the increasing demand, we have decided to offer all ATLANTA Servo Gear Units with food-grade lubricant. For this we have introduced a separate article number range, which you will find in our new catalog *Servo Drive System edition 1/2015*, chapter GA to GE.

Example for ordering of ATLANTA servo gear units with food grade lubricant:

	Synthetic Oil	Food Grade Oil
HT High-Torque	98 03 005	98 03 105
HP High-Performance	58 03 005	58 03 105
E Economy	59 03 005	59 03 105
B Basic	57 03 005	57 03 105







© Dmitry Vereshchagin / Fotolia.com



© 445017 / Fotolia.com



	Page	
HT High-Torque Gear Units with <1' Adjustable Backlash	GA2 – GA9	
Center Distance 50 mm	GA2 – GA3	
Center Distance 63 mm	GA4 – GA5	
Center Distance 80 mm	GA6 – GA7	
Center Distance 100 mm	GA8 – GA9	
Couplings and Shrink-Disk	GA10	
Selection and Load Tables	GA11 – GA13	
Short Description	GA14	
Mounting and Maintenance	GA15 – GA16	
Gear Units Calculation and Selection	GF1 – GF3	
Gear Units Accessories	GG1 – GG8	
Motor Applications	GI1 – GI4	



Center Distance

$a_o = 50 \text{ mm}$

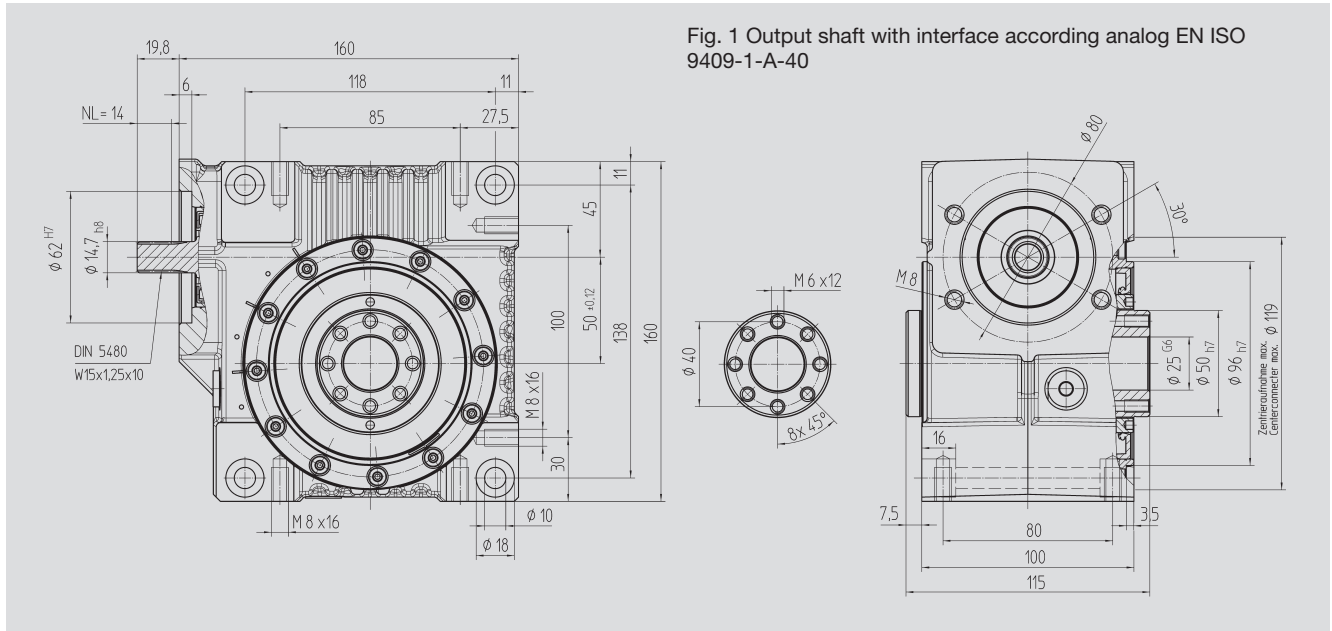

Fig. 1 Output shaft with interface according analog EN ISO 9409-1-A-40

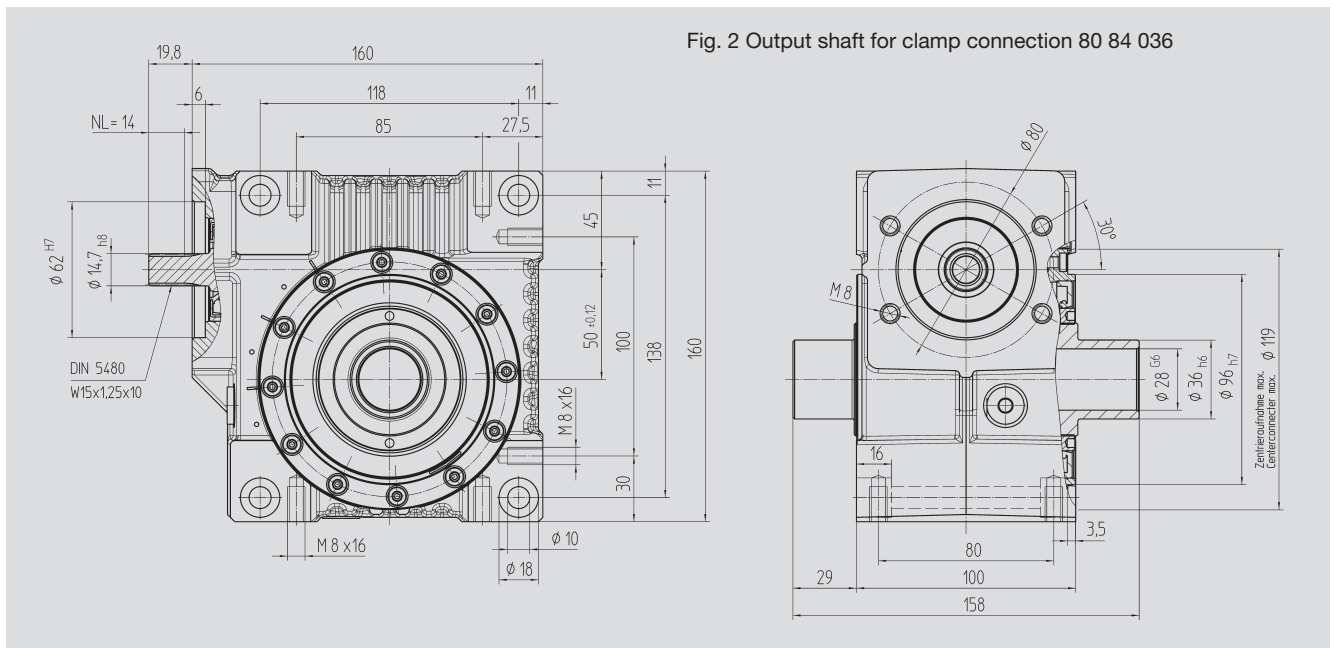

Fig. 2 Output shaft for clamp connection 80 84 036

Order Code Fig. 1	Fig. 2	Ratio i	kg	$J_{red} 10^{-4}$ kg m ²
98 03 005	98 13 005	4.75	7	0.8280
98 03 007	98 13 007	6.75	7	0.4140
98 03 009	98 13 009	9.25	7	0.3490
98 03 015	98 13 015	14.50	7	0.2800
98 03 020	98 13 020	19.50	7	0.1960
98 03 029	98 13 029	29.00	7	0.2694
98 03 039	98 13 039	39.00	7	0.2310
98 03 050	98 13 050	50.00	7	0.2140

With food grade oil, order code 98 03 1xx / 98 13 1xx

With ATEX version with food grade oil, order code 98 03 2xx / 98 13 2xx



Motor Flange

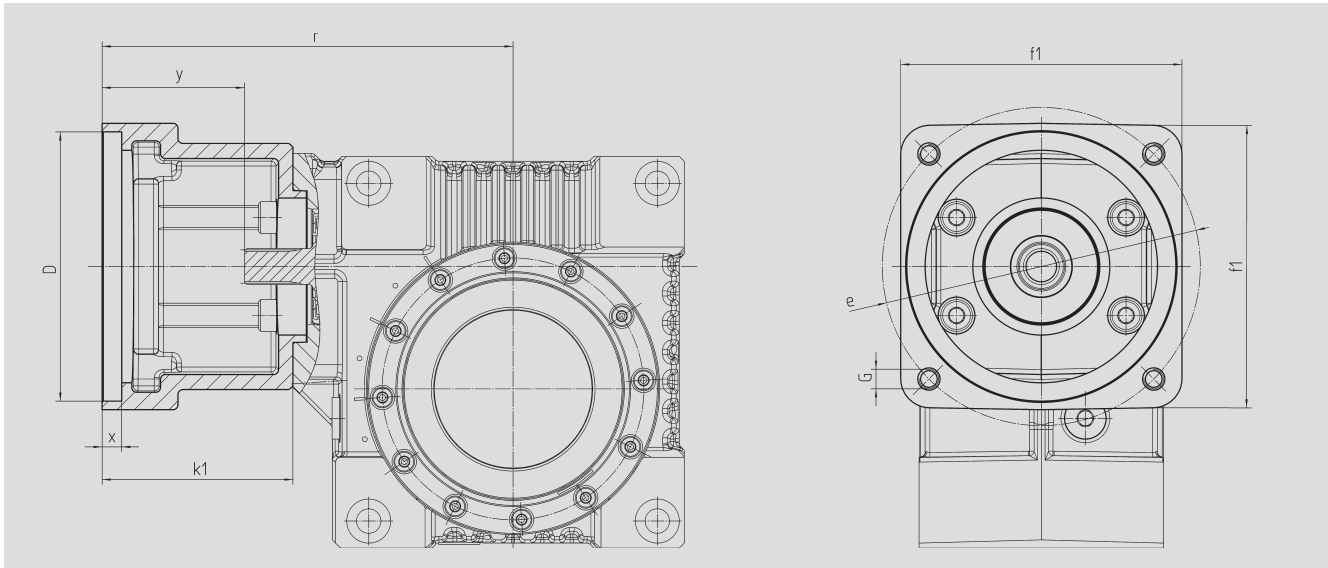

Center Distance

$a_o = 50 \text{ mm}$

Order Code	D ^{G7}	k ₁	r	x	y	f ₁	e	G	kg
65 59 301	95.0	62	152	12.5	42	100	115	M8	0.60
65 59 302	50.0	62	152	10.0	42	100	70, 95, 115	M4, M6, M8	0.70
65 59 303	80.0	62	152	10.0	42	100	100	M6	0.65
65 59 304	95.0	78	168	10.0	58	115	130	M8	0.80
65 59 305	95.0	72	162	8.0	52	100	115	M8	0.75
65 59 306	60.0	74	164	21.0	54	100	75, 90, 115	M5, M5, M8	0.90
65 59 307	70.0	70	160	21.0	50	100	90, 115	M6, M8	0.80
65 59 401	95.0	73	163	8.0	53	100	115	M8	0.75
65 59 402	110.0	78	168	8.0	58	115	130	M8	0.80
65 59 403	95.0	73	163	12.0	53	115	130	M8	0.75
65 59 404	110.0	73	163	12.0	53	115	130	M8	0.70
65 59 405	95.0	78	168	11.0	58	140	165	M10	1.20
65 59 406	110.0	78	168	11.0	58	140	165	M10	1.15
65 59 407	130.0	78	168	11.0	58	140	165	M10	1.00
65 59 409	130.0	98	188	14.0	78	140	165	M10	1.10
65 59 410	110.0	74	164	8.0	54	120	145	M8	1.00
65 59 411	110.0	84	174	8.0	64	120	145	M8	1.20
65 59 412	114.3	105	195	8.0	85	180	200	M12	3.70
65 59 413	114.3	139	229	8.0	119	180	200	M12	3.35
65 59 414	114.3	91	181	8.0	71	180	200	M12	2.65
65 59 415	110.0	89	179	8.0	69	120	145	M8	1.30

The order should contain gear box 98 03 0xx / 98 13 0xx and flange 65 59 3xx or 4xx.



Center Distance

$a_o = 63 \text{ mm}$

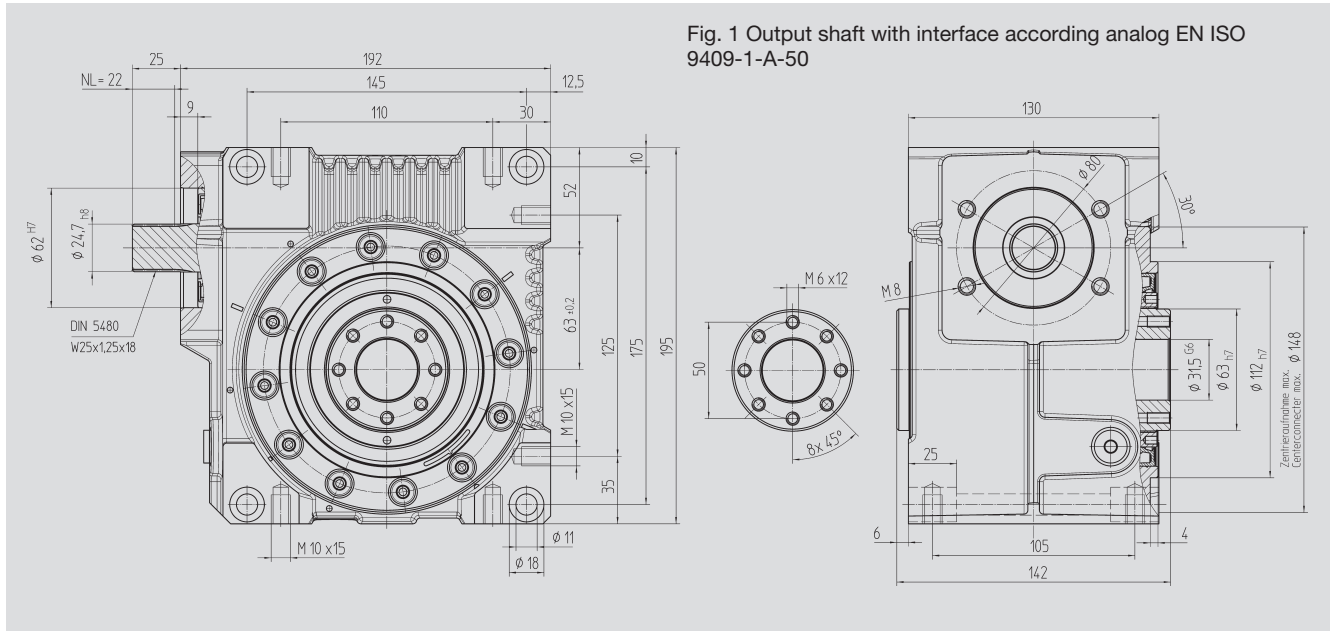

Fig. 1 Output shaft with interface according analog EN ISO 9409-1-A-50

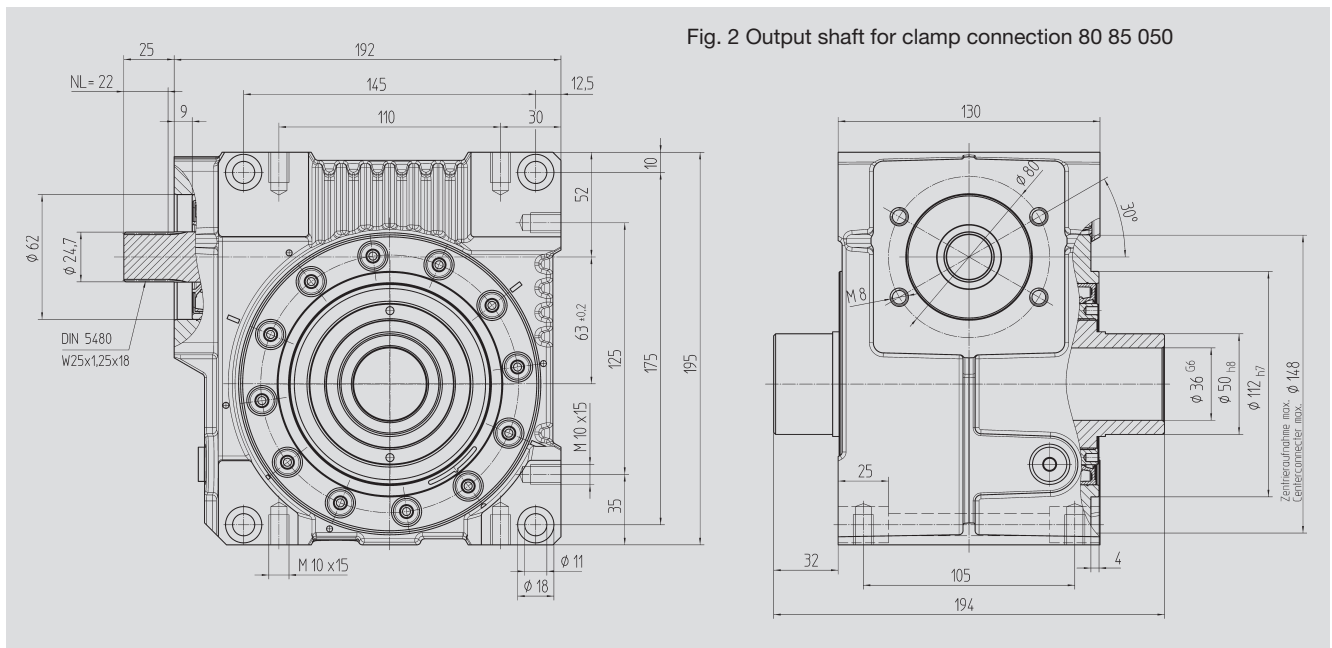

Fig. 2 Output shaft for clamp connection 80 85 050

Order Code Fig. 1	Fig. 2	Ratio i	kg	$J_{red} 10^{-4}$ kg m ²
98 04 005	98 14 005	4.75	12	2.5350
98 04 007	98 14 007	6.75	12	1.3720
98 04 009	98 14 009	9.25	12	0.9825
98 04 015	98 14 015	14.50	12	0.9590
98 04 020	98 14 020	19.50	12	0.6940
98 04 029	98 14 029	29.00	12	0.9966
98 04 039	98 14 039	39.00	12	1.0100
98 04 052	98 14 052	52.00	12	0.5305

With food grade oil, order code 98 04 1xx / 98 14 1xx

With ATEX version with food grade oil, order code 98 04 2xx / 98 14 2xx



Motor Flange

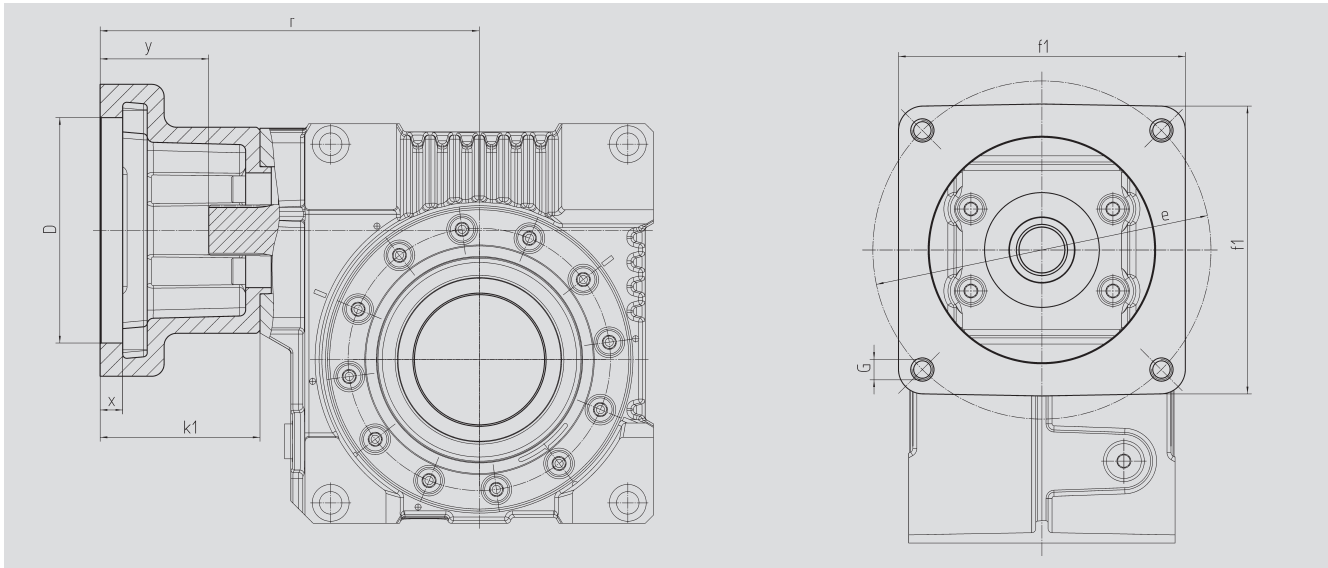

Center Distance

$a_o = 63 \text{ mm}$

Order Code	D ^{G7}	k ₁	r	x	y	f ₁	e	G	kg
65 59 301	95.0	62	169	12.5	37	100	115	M8	0.60
65 59 302	50.0	62	169	10.0	37	100	70, 95, 115	M4, M6, M8	0.70
65 59 303	80.0	62	169	10.0	37	100	100	M6	0.65
65 59 304	95.0	78	185	10.0	53	115	130	M8	0.80
65 59 305	95.0	72	179	8.0	47	100	115	M8	0.75
65 59 306	60.0	74	181	21.0	49	100	75, 90, 115	M5, M5, M8	0.90
65 59 307	70.0	70	177	21.0	45	100	90, 115	M6, M8	0.80
65 59 401	95.0	73	180	8.0	48	100	115	M8	0.75
65 59 402	110.0	78	185	8.0	48	115	130	M8	0.80
65 59 403	95.0	73	180	12.0	48	115	130	M8	0.75
65 59 404	110.0	73	180	12.0	48	115	130	M8	0.70
65 59 405	95.0	78	185	11.0	53	140	165	M10	1.20
65 59 406	110.0	78	185	11.0	53	140	165	M10	1.15
65 59 407	130.0	78	185	11.0	53	140	165	M10	1.00
65 59 409	130.0	98	205	14.0	73	140	165	M10	1.10
65 59 410	110.0	74	181	8.0	49	120	145	M8	1.00
65 59 411	110.0	84	191	8.0	59	120	145	M8	1.20
65 59 412	114.3	105	212	8.0	80	180	200	M12	3.70
65 59 413	114.3	139	246	8.0	114	180	200	M12	3.35
65 59 414	114.3	91	198	8.0	66	180	200	M12	2.65
65 59 415	110.0	89	196	8.0	64	120	145	M8	1.30

The order should contain gear box 98 04 0xx / 98 14 0xx and flange 65 59 3xx or 4xx.



Center Distance

$$a_o = 80 \text{ mm}$$

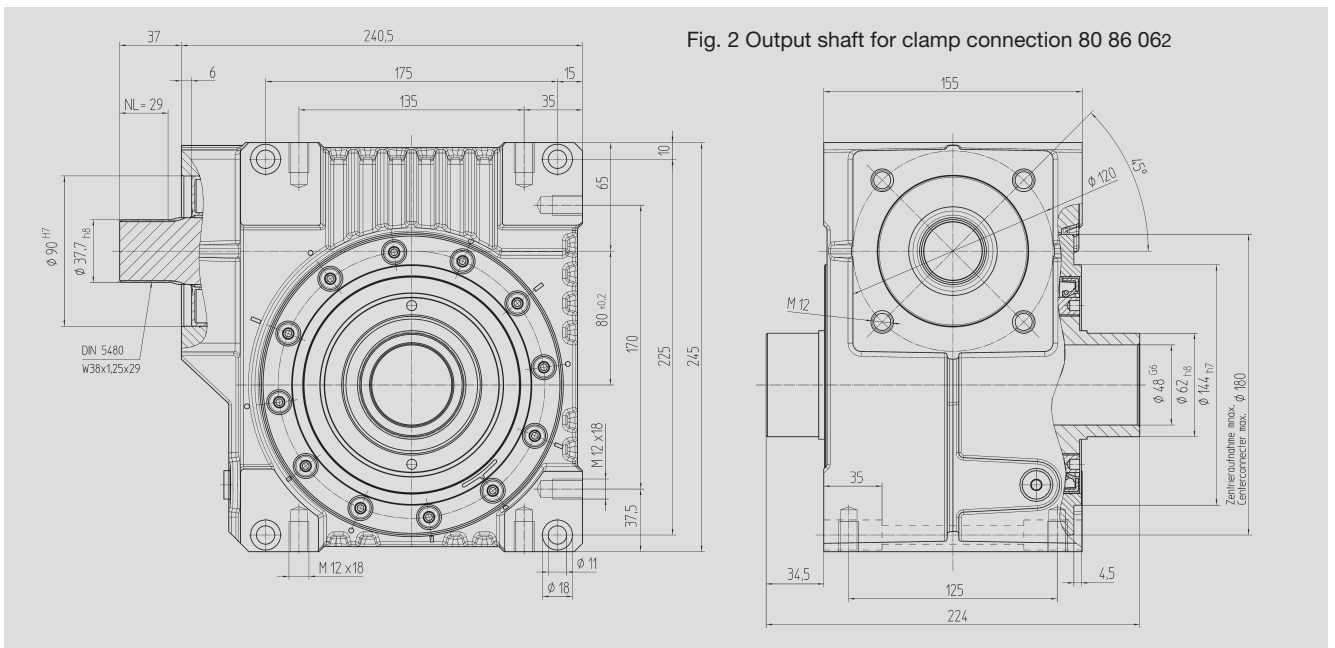
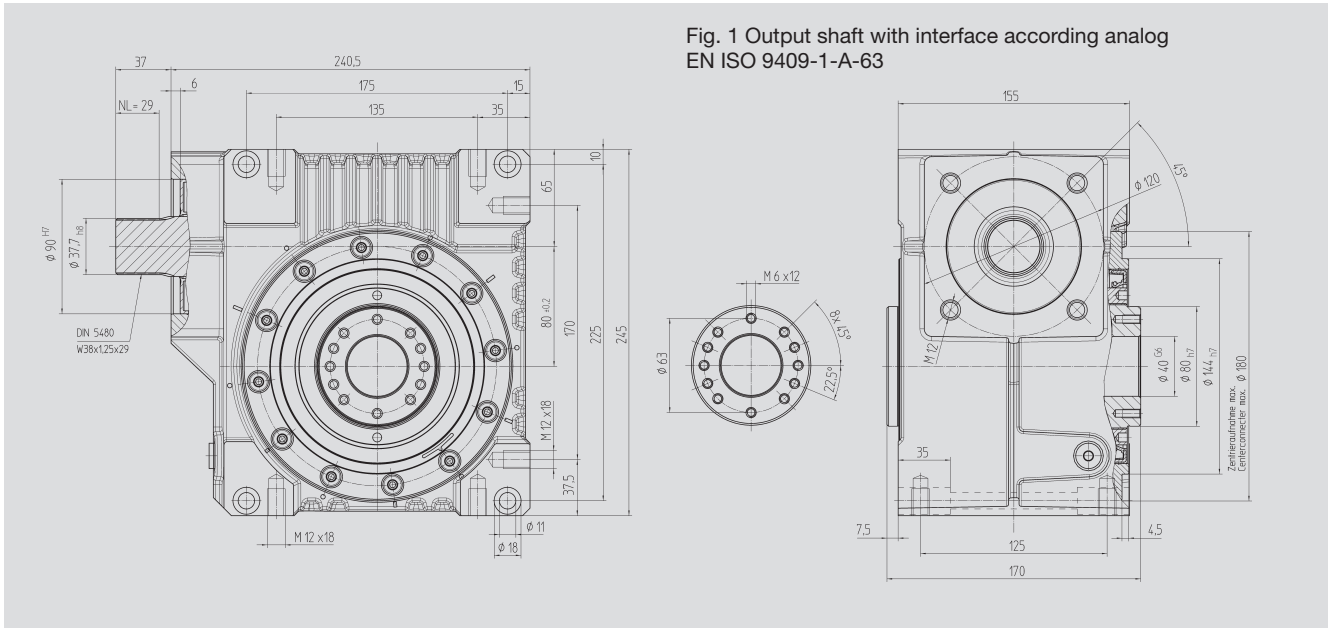

Order Code Fig. 1	Fig. 2	Ratio i		J _{red} 10 ⁻⁴ kg m ²
98 05 005	98 15 005	4.75	23	9.6180
98 05 007	98 15 007	6.75	23	6.0910
98 05 009	98 15 009	9.25	23	4.7650
98 05 015	98 15 015	14.50	23	5.3080
98 05 020	98 15 020	19.50	23	3.9350
98 05 029	98 15 029	29.00	23	4.0500
98 05 039	98 15 039	39.00	23	4.1800
98 05 052	98 15 052	52.00	23	3.7140

With food grade oil, order code 98 05 1xx / 98 15 xx

With ATEX version with food grade oil, order code 98 05 2xx / 98 15 2xx



Motor Flange

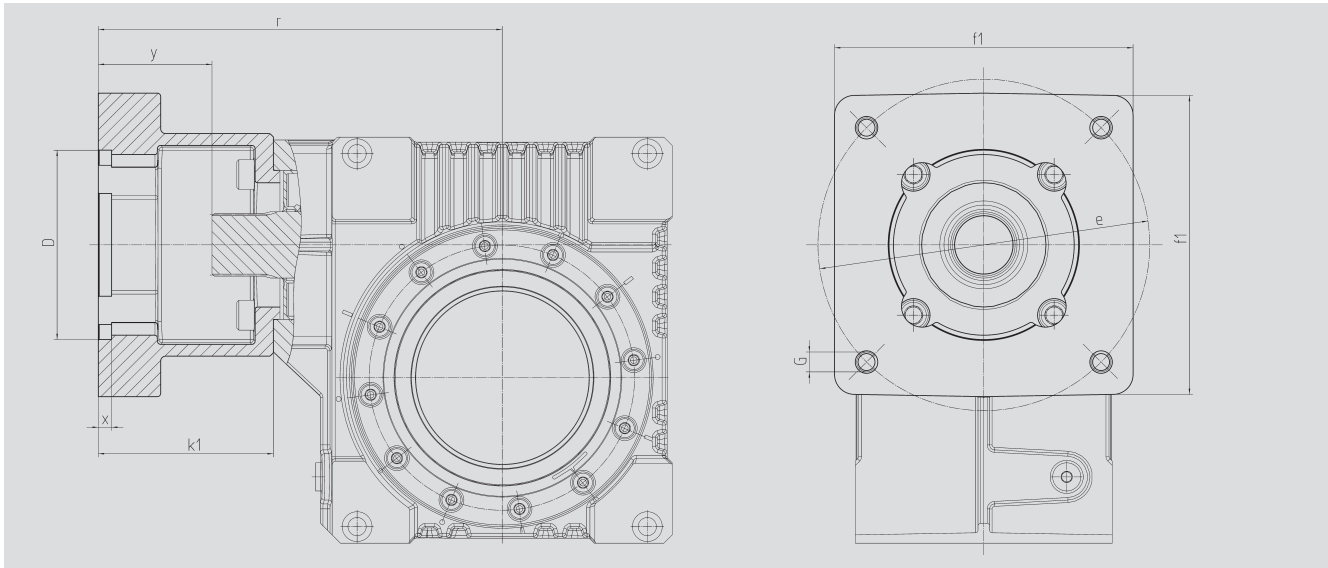

Center Distance

$a_o = 80 \text{ mm}$

Order Code	D ^{G7}	k ₁	r	x	y	f ₁	e	G	kg
65 59 501	110.0	92.0	230.0	8.0	55.0	140	165	M10	2.00
65 59 502	130.0	92.0	230.0	8.0	55.0	140	165	M10	1.90
65 59 503	180.0	122.0	260.0	8.0	85.0	192	215	M12	3.40
65 59 504	180.0	127.0	265.0	8.0	90.0	192	215	M12	3.80
65 59 505	180.0	112.0	250.0	10.0	75.0	192	215	M12	2.70
65 59 506	130.0	112.0	250.0	10.0	75.0	192	215	M12	3.00
65 59 507	130.0	112.0	250.0	10.0	75.0	140	165	M10	2.50
65 59 508	110.0	90.0	228.0	8.0	53.0	140	145	M8	2.00
65 59 509	110.0	108.5	246.5	8.0	71.5	140	145	M8	2.50
65 59 510	114.3	129.5	267.5	8.0	92.5	180	200	M12	5.00
65 59 511	114.3	163.5	301.5	8.0	126.5	180	200	M12	4.20
65 59 512	114.3	105.5	243.5	8.0	68.5	180	200	M12	3.50
65 59 513	110.0	113.5	251.5	8.0	76.5	140	145	M8	2.70

The order should contain gear box 98 05 0xx / 98 15 0xx and flange 65 59 5xx.



Center Distance

$a_o = 100 \text{ mm}$

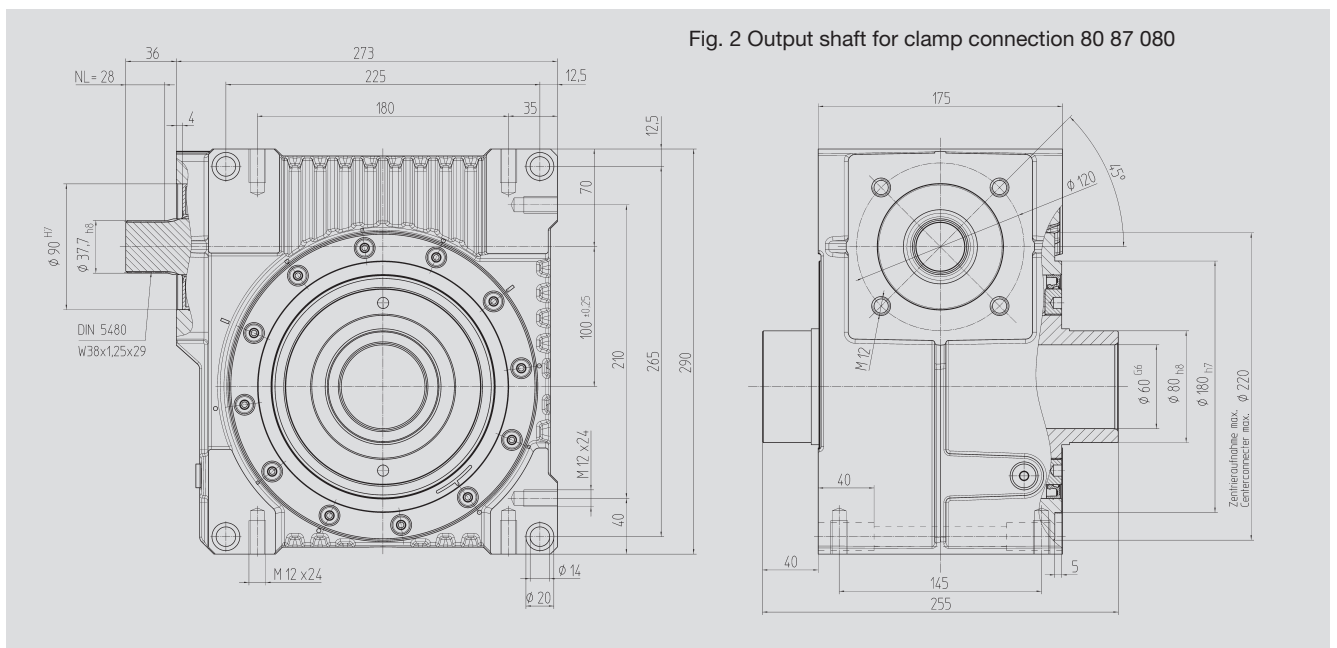
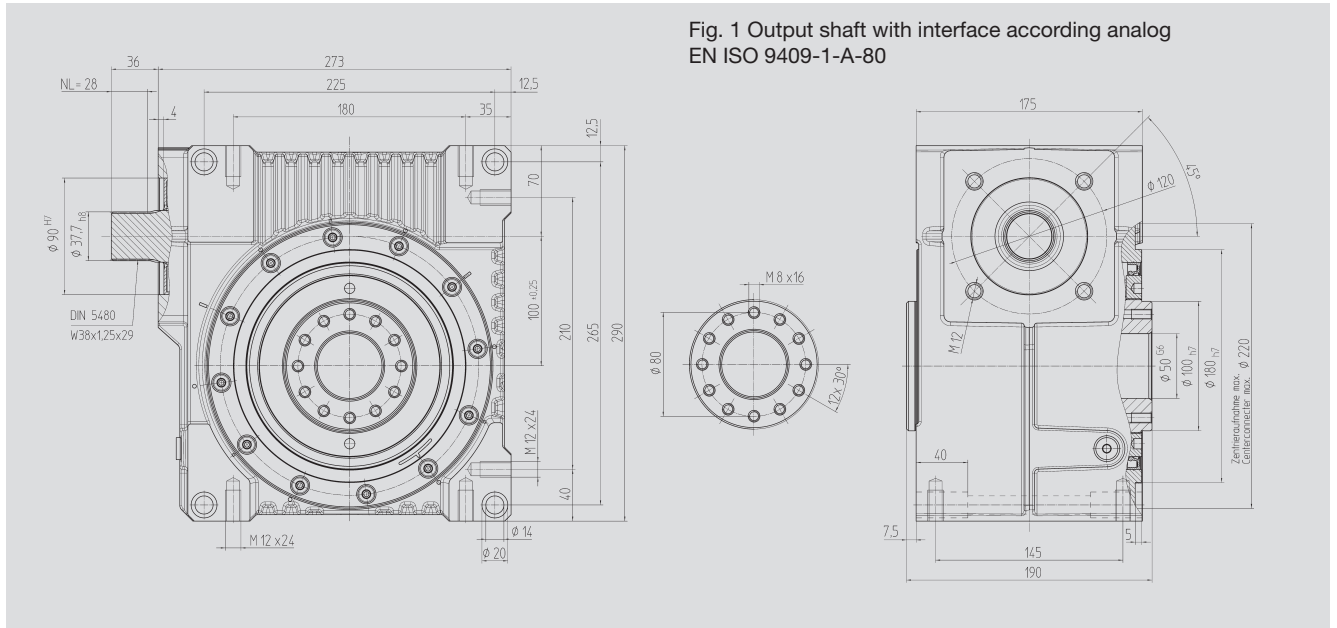

Order Code Fig. 1	Fig. 2	Ratio i		J_{red} 10 ⁻⁴ kg m ²
98 06 005	98 16 005	4.75	38	22.9320
98 06 007	98 16 007	6.75	38	12.8835
98 06 009	98 16 009	9.25	38	8.0975
98 06 015	98 16 015	14.50	38	7.2190
98 06 020	98 16 020	19.50	38	5.4030
98 06 029	98 16 029	29.00	38	4.7207
98 06 039	98 16 039	39.00	38	8.4300
98 06 052	98 16 052	52.00	38	9.7400

With food grade oil, order code 98 06 1xx / 98 16 1xx

With ATEX version with food grade oil, order code 98 06 2xx / 98 16 2xx



Motor Flange

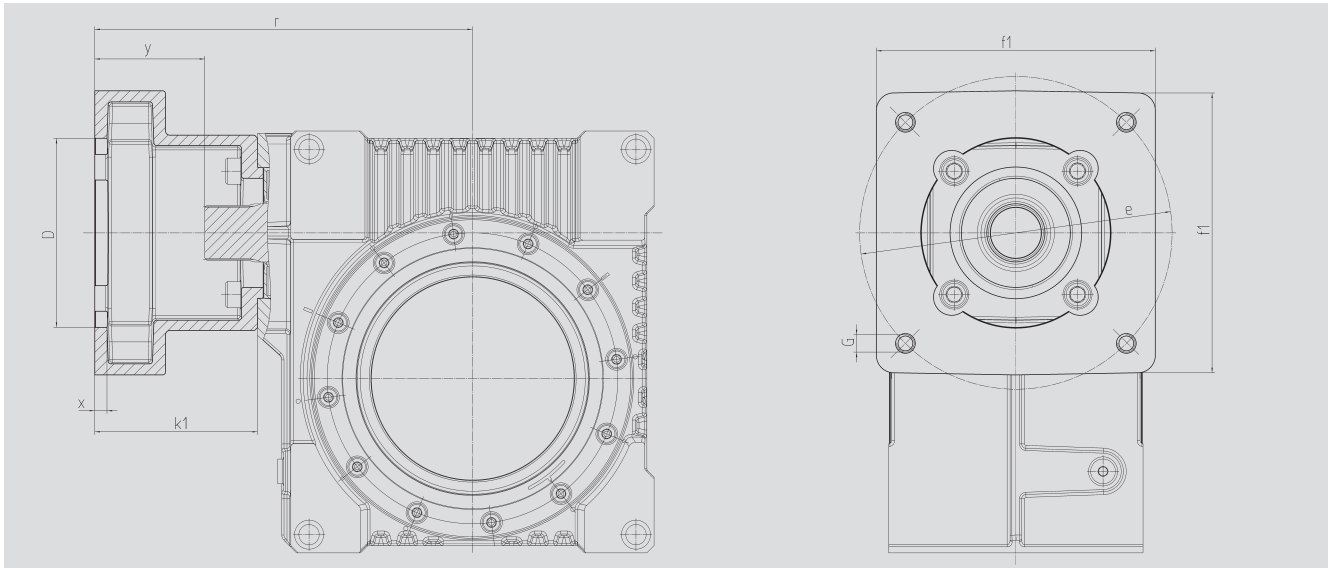

Center Distance

$a_o = 100 \text{ mm}$

Order Code	D ^{G7}	k ₁	r	x	y	f ₁	e	G	 kg
65 59 501	110.0	92.0	240.0	8.0	55.0	140	165	M10	2.00
65 59 502	130.0	92.0	240.0	8.0	55.0	140	165	M10	1.90
65 59 503	180.0	122.0	270.0	8.0	85.0	192	215	M12	3.40
65 59 504	180.0	127.0	275.0	8.0	90.0	192	215	M12	3.80
65 59 505	180.0	112.0	260.0	10.0	75.0	192	215	M12	2.70
65 59 506	130.0	112.0	260.0	10.0	75.0	192	215	M12	3.00
65 59 507	130.0	112.0	260.0	10.0	75.0	140	165	M10	2.50
65 59 508	110.0	90.0	238.0	8.0	53.0	140	145	M8	2.00
65 59 509	110.0	108.5	256.5	8.0	71.5	140	145	M8	2.50
65 59 510	114.3	129.5	277.5	8.0	92.5	180	200	M12	5.00
65 59 511	114.3	163.5	311.5	8.0	126.5	180	200	M12	4.20
65 59 512	114.3	105.5	253.5	8.0	68.5	180	200	M12	3.50
65 59 513	110.0	113.5	261.5	8.0	76.5	140	145	M8	2.70

The order should contain gear box 98 06 0xx / 98 16 0xx and flange 65 59 5xx.



Special Couplings for Motor/Gear Units, rigid model, nitrided, preassembled for motor shafts without key

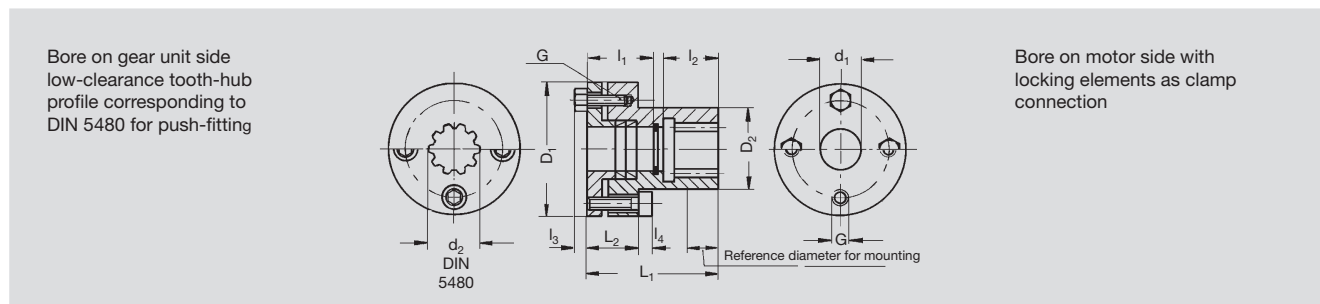

Order Code													J_{red}	
Coupling	1)	d_1	d_2	D_1	D_2	l_1	l_2	l_3	l_4	L_1	L_2	G	10^{-4} kg m^2	
65 43 110	9 71 80 010	10	15x1.25x10	48	29	22	17	-	5	44	18	4xM5	0.835	0.40
65 43 111	9 71 80 011	11	15x1.25x10	48	29	20.5	17	-	5	64	18	4xM5	0.976	0.50
65 43 114	9 71 80 014	14	15x1.25x10	48	29	24	19	-	5	50	18	4xM5	0.835	0.45
65 43 116	9 71 80 016	16	15x1.25x10	48	29	27	16	-	5	50	18	4xM5	0.824	0.45
65 43 119	9 71 80 019	19	15x1.25x10	48	29	24	16	-	5	40	18	4xM5	0.799	0.40
65 43 914	9 71 80 014	14	15x1.25x10	48	29	26	19	-	5	64	18	4xM5	0.985	0.50
65 43 916	9 71 80 016	16	15x1.25x10	48	29	27	15	-	5	64.3	18.3	4xM5	0.975	0.40
65 43 919	9 71 80 019	19	15x1.25x10	48	29	23	17	-	5	55	18	4xM5	0.853	0.45
65 43 924	9 71 80 024	24	15x1.25x10	50	29	34	22	-	6	56	40	4xM6	1.041	0.52
65 44 024	9 71 80 024	24	25x1.25x18	50	29	41.5	24	-	6	66.5	59.5	4xM6	2.628	0.75
65 44 114	9 71 80 014	14	25x1.25x18	55	32	24	23.5	-	6	64	21	4xM6	1.645	0.50
65 44 116	9 71 80 016	16	25x1.25x18	55	32	34	23.5	-	6	64	21	4xM6	1.622	0.50
65 44 119	9 71 80 019	19	25x1.25x18	55	32	33	26.5	-	6	63	21	4xM6	1.598	0.50
65 44 120	9 71 80 020	20	25x1.25x18	55	32	33.2	26.5	-	6	63	21	4xM6	1.550	0.50
65 44 219	9 71 80 019	19	25x1.25x18	55	32	27	26.5	-	6	74	21	4xM6	1.703	0.50
65 44 919	9 71 80 019	19	25x1.25x18	55	32	31	26.5	-	6	78	21	4xM6	1.757	0.55
65 44 928	9 71 80 028	28	25x1.25x18	70	48	48	26	-	6	83	25	5xM6	5.998	0.85
65 44 932	9 71 80 032	32	25x1.25x18	70	48	43	23	-	6	78	25	5xM6	5.921	0.80
65 44 935	9 71 81 035	35	25x1.25x18	70	48	52	26	-	6	78	25	5xM6	6.155	0.95
65 46 024	9 71 80 024	24	38x1.25x29	55	-	38.5	31	4	6	72.5	-	5xM6	4.452	0.90
65 46 834	9 71 81 035	1 3/8"	38x1.25x29	80	58	63	34	-	6	100	40	6xM6	16.320	1.95
65 46 928	9 71 80 028	28	38x1.25x29	70	48	47	34	-	6	90	25	5xM6	5.882	0.90
65 46 932	9 71 80 032	32	38x1.25x29	70	48	43	34	-	6	86	25	5xM6	5.784	0.85
65 46 935	9 71 81 035	35	38x1.25x29	80	58	65	34	-	6	100	40	6xM6	16.550	1.95
65 46 938	9 71 80 038	38	38x1.25x29	80	58	62	34	-	6	100	40	6xM6	16.240	1.88
65 47 948	9 71 80 048	48	38x1.25x29	95	66	58	31	-	8	92	42	6xM8	41.860	3.10

1) Spare part clamping element

Shrink-Disk Clamping Sets for Output Drive Shafts of gear series 98 1. ...

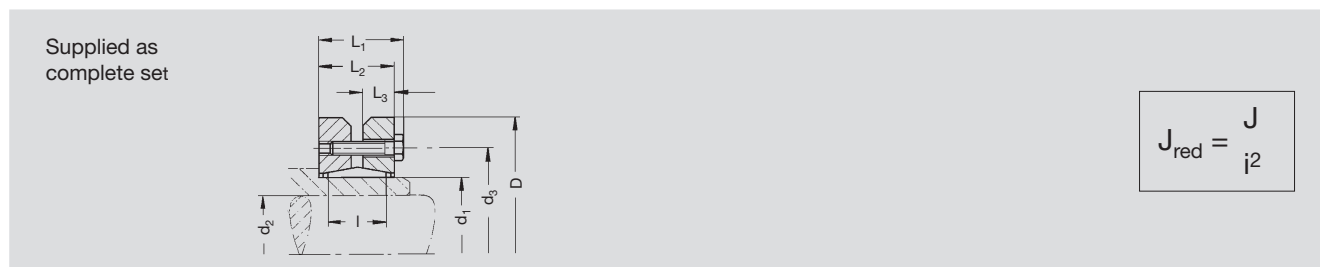

Order Code	a_0 mm	T_{2max} Nm	d_1	d_2	d_3	D	L_1	L_2	L_3	I	G	J 10^{-4} kg m^2	
80 84 036	50	540	36	28	52	72	27.5	23.50	10	18	5 x M6	4.029	0.4
80 85 050	63	1180	50	36	70	90	31.5	27.50	12	22	9 x M6	11.322	0.8
80 86 062	80	2300	62	48	86	110	34.5	30.50	13	23	12 x M6	27.137	1.3
80 87 080	100	3240	80	60	100	145	38.0	32.50	14	25	7 x M8	88.870	1.9



Gearing efficiency of servo worm gear units with driving worm and under full load.

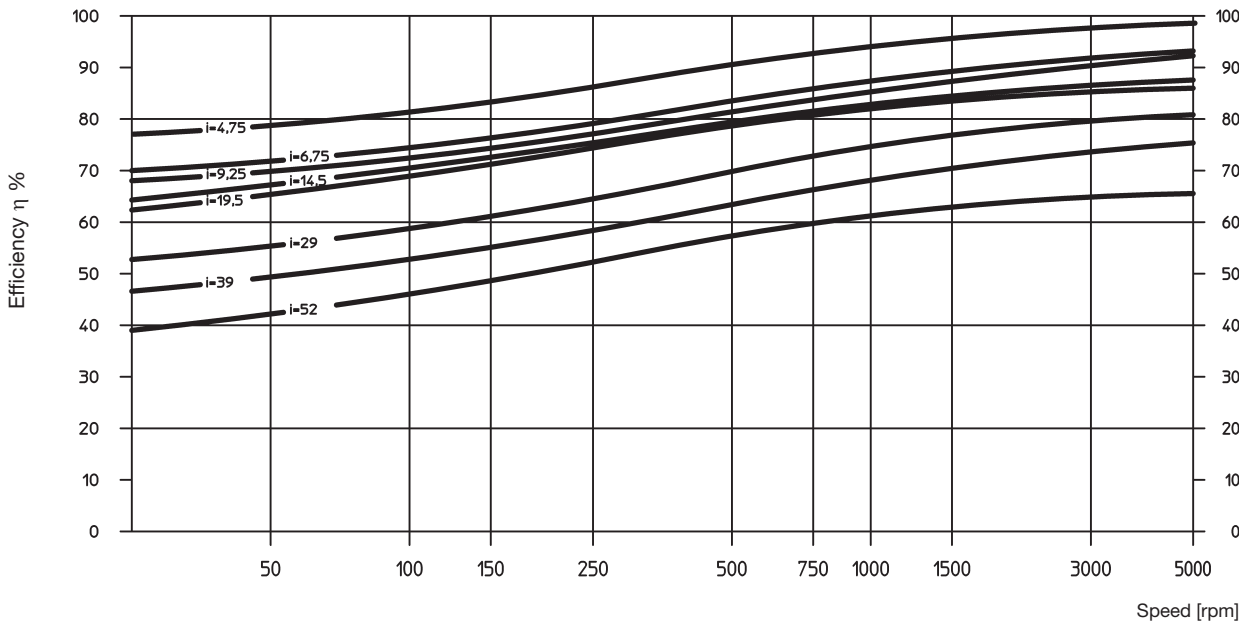

Additional loads on output drive

The data given are reference values. You should consider the values arising from the choice of the tooth system. It is assumed that the point of action of the force is the center of the shaft. In cases where additional axial forces occur, over and above high transverse forces, please ask for advice.

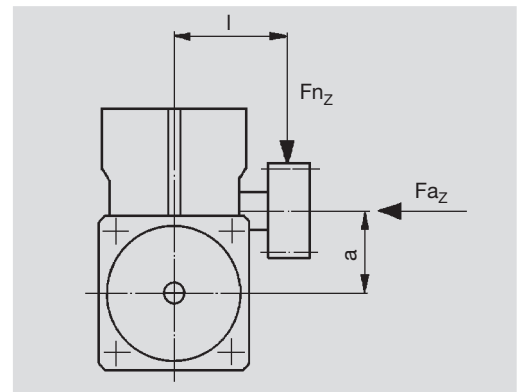

Center Distance a (mm)	50		63		80		100	
Dimension center of casing to center of pinion	EN ISO	Clamp Connect.	EN ISO	Clamp Connect.	EN ISO	Clamp Connect.	EN ISO	Clamp Connect.
l (mm)	71	105	86	120	103	135	118	162
Max. additional load								
radial F_{n_z} [N]	6800	4600	9600	7000	15300	11700	17800	13200
axial F_{a_z} [N]	2700	2700	3800	3800	6000	6000	7500	7500
Only axial load F_{a_z} [N] ($F_n = 0$)	5000		8000		15000		35000	



The values in the tables are based upon wear or maximum flank load at 12,000 hours full load and on servo-operation. With continuous full-load operation it may be necessary to consider temperature limits! (Please ask us if in doubt.)

T_{2max} = static torque to avoid tooth fracture, T_1 = input torque in Nm, T_2 = output torque in Nm.

Order Code	a_0 (mm)	i	T_{2max}	Input Speed n_1 (rpm)												
				250		500		750		1000		1500		2000		
				T_1 (Nm)	T_2 (Nm)	T_1 (Nm)	T_2 (Nm)	T_1 (Nm)	T_2 (Nm)	T_1 (Nm)	T_2 (Nm)	T_1 (Nm)	T_2 (Nm)	T_1 (Nm)	T_2 (Nm)	
98 03 003 98 13 003	50	3.00*														
98 03 005 98 13 005		4.75	820	17.4	73	22.7	97	22.7	97	24.4	105	24.6	105	24.8	105	
98 03 007 98 13 007		6.75	600	10.8	63	14.1	84	14.8	88	15.7	94	17.1	103	17.1	103	
98 03 009 98 13 009		9.25	410	7.2	53	9.4	72	9.8	76	10.4	81	11.1	87	11.9	93	
98 03 015 98 13 015		14.50	520	5.5	64	7.1	85	7.5	90	8.0	97	8.7	105	8.9	107	
98 03 020 98 13 020		19.50	370	3.6	50	4.6	67	4.9	72	5.1	75	5.5	82	5.8	87	
98 03 029 98 13 029		29.00	450	2.9	54	3.7	72	3.9	78	4.0	82	4.4	90	4.7	95	
98 03 039 98 13 039		39.00	300	2.7	58	3.4	78	3.6	84	3.8	90	4.0	97	4.2	102	
98 03 050 98 13 050		50.00	220	2.3	47	2.8	63	2.8	66	2.9	70	3.1	75	3.3	80	
98 04 003 98 14 003	63	3.00*														
98 04 005 98 14 005		4.75	1500	56.3	244	58.4	255	61.8	270	61.9	270	58.7	255	56.1	242	
98 04 007 98 14 007		6.75	1120	32.3	194	41.9	255	44.2	270	44.2	270	41.8	255	39.9	242	
98 04 009 98 14 009		9.25	750	16.2	128	21.3	172	23.0	187	23.9	195	24.6	202	24.6	202	
98 04 015 98 14 015		14.50	900	16.7	198	20.3	247	22.1	270	22.1	270	22.1	270	21.7	265	
98 04 020 98 14 020		19.50	750	8.4	130	10.7	172	11.6	187	12.0	195	12.5	202	13.4	217	
98 04 029 98 14 029		29.00	970	10.3	206	12.6	262	13.6	285	14.6	307	15.7	330	15.2	317	
98 04 039 98 14 039		39.00	670	6.3	159	7.8	210	8.2	225	8.8	240	9.6	262	9.8	270	
98 04 052 98 14 052		52.00	450	3.7	106	4.5	142	4.9	157	5.3	172	5.7	187	6.1	200	
98 05 003 98 15 003	80	3.00*														
98 05 005 98 15 005		4.75	3000	154.3	680	142.3	630	128.9	570	122.2	540	112.5	495	107.3	470	
98 05 007 98 15 007		6.75	2100	97.8	603	101.3	630	91.6	570	86.8	540	79.8	495	76.1	470	
98 05 009 98 15 009		9.25	1650	56.3	465	66.2	555	66.1	555	64.3	540	59.0	495	56.2	470	
98 05 015 98 15 015		14.50	1950	52.4	646	53.9	675	53.7	675	50.1	630	44.1	555	41.3	517	
98 05 020 98 15 020		19.50	1500	32.9	530	33.7	555	36.3	600	36.2	600	32.6	540	31.4	520	
98 05 029 98 15 029		29.00	1800	34.4	747	35.0	780	36.8	825	35.4	795	32.7	735	31.3	700	
98 05 039 98 15 039		39.00	1270	22.5	617	22.7	645	24.0	690	25.6	735	25.0	720	23.9	685	
98 05 052 98 15 052		52.00	900	9.4	325	9.9	360	10.7	390	11.2	412	12.3	450	12.7	465	
98 06 005 98 16 005	100	4.75	4950	351.4	1564	295.9	1320	269.3	1200	253.6	1125	231.5	1027	220.6	975	
98 06 007 98 16 007		6.75	3450	190.8	1195	197.7	1245	178.6	1125	172.2	1080	157.9	990	152.0	950	
98 06 009 98 16 009		9.25	2850	141.4	1192	146.5	1245	132.2	1125	127.2	1080	116.6	990	112.2	950	
98 06 015 98 16 015		14.50	3070	105.1	1338	108.3	1395	102.3	1320	94.4	1215	83.9	1080	80.3	1030	
98 06 020 98 16 020		19.50	2700	77.8	1292	79.9	1350	77.0	1305	71.7	1215	63.7	1080	60.9	1030	
98 06 029 98 16 029		29.00	3450	73.0	1654	74.8	1725	69.2	1605	65.5	1515	55.2	1275	54.4	1250	
98 06 039 98 16 039		39.00	2470	52.8	1551	53.7	1620	51.0	1545	49.4	1500	44.5	1350	42.7	1290	
98 06 052 98 16 052		52.00	1650	31.1	1139	30.1	1140	32.2	1230	33.4	1275	30.8	1177	29.5	1125	

* On request



Input Speed n_1 (rpm)															
2500		3000		3500		4000		4500		5000		5500		6000	
T_1 (Nm)	T_2 (Nm)	T_1 (Nm)	T_2 (Nm)	T_1 (Nm)	T_2 (Nm)	T_1 (Nm)	T_2 (Nm)	T_1 (Nm)	T_2 (Nm)	T_1 (Nm)	T_2 (Nm)	T_1 (Nm)	T_2 (Nm)	T_1 (Nm)	T_2 (Nm)
25.0	105	25.2	105	24.5	101	23.7	97	23.2	94	22.7	91	21.4	85	20.4	80
17.2	103	17.3	103	16.9	100	16.5	97	16.1	94	15.7	91	14.9	86	14.1	81
12.6	99	13.3	105	13.3	105	13.4	105	13.0	101	12.6	97	11.9	92	11.4	87
9.1	110	9.3	112	9.4	112	9.4	112	9.5	112	9.6	112	9.1	106	8.7	100
6.1	92	6.5	97	6.5	97	6.5	97	6.5	97	6.6	97	6.2	91	5.9	86
4.9	100	5.2	105	5.2	105	5.3	105	5.1	101	5.0	97	4.7	91	4.5	86
4.4	107	4.6	112	4.6	112	4.6	112	4.6	112	4.7	112	4.5	105	4.3	100
3.4	85	3.6	90	3.6	90	3.6	90	3.6	90	3.6	90	3.7	93	3.8	95
53.4	230	50.8	217	49.3	210	47.8	202	44.4	186	41.3	172				
38.1	230	36.1	217	35.1	210	34.0	202	31.7	187	29.7	174	27.9	163		
24.6	202	24.7	202	24.0	196	23.4	189	21.9	176	20.7	165	19.6	156	18.6	147
21.4	260	21.1	255	20.6	248	20.1	240	18.7	222	17.6	207	16.6	194		
14.4	232	15.4	247	14.9	240	14.5	232	13.7	217	12.9	204	12.2	192	11.7	181
14.6	305	14.1	292	13.9	285	13.6	277	12.8	257	12.0	239	11.3	223		
10.2	277	10.5	285	10.5	285	10.7	285	10.0	266	9.5	249	9.0	234	8.6	221
6.5	212	6.9	225	7.2	233	7.4	240	7.2	232	6.9	218	6.6	205	6.3	194
102.2	445	96.8	420	88.4	381	79.9	343								
72.4	445	68.6	420	63.0	384	57.3	347	53.0	320	49.4	297				
53.5	445	50.7	420	46.8	386	42.8	352	39.8	326	37.3	303	35.0	283		
38.5	480	35.6	442	32.8	405	30.0	368	27.8	340	25.9	315				
30.3	500	29.2	480	27.1	442	24.9	404	23.1	374	21.7	349	20.4	326		
29.9	665	28.5	630	26.3	576	24.0	523	22.3	482						
22.8	650	21.7	615	20.1	566	18.5	517	17.3	478	16.3	445	15.3	417		
13.2	480	13.7	495	13.7	495	13.8	494	13.0	462	12.3	432	11.6	407		
209.5	922	198.4	870												
146.1	910	140.2	870	126.5	782	103.8	639								
107.9	910	103.5	870	94.3	789	78.3	654	79.9	663	74.5	616				
76.6	980	73.0	930	66.0	838	60.4	763								
58.2	980	55.5	930	50.6	845	46.6	775	43.2	715	0.8	663				
53.6	1225	52.8	1200	47.9	1081										
41.0	1230	39.2	1170	35.8	1061	29.9	881	30.6	896						
28.2	1072	26.9	1020	24.8	931	23.0	856	21.5	792	18.8	691				



Short Description

ATLANTA HT High-Torque Worm Gear Units have been specially developed for use with the latest three-phase and DC servo-motors. Like all other components in this catalog, they are usually available ex stock or, at least, within a very short time.

The following are typical features of our HT high-torque gear units:

- low-clearance gearing (backlash < 1'), adjustable
- up to 150% higher loading values
- casing of light metal for optimal heat dissipation
- robust bevel roller bearings for the output drive hollow shaft in "O" arrangement permitting greater additional forces.

Center distances, gear ratios and tooth systems have been chosen in accordance with DIN 3975/76. The tooth shape was optimised so as to permit the adjustment of the clearance simply by changing the center distance by means of eccentric flanges.

The use of ground, right-hand worms, a worm gear of special worm-gear bronze and dip-feed lubrication (synthetic special oil) ensures a high degree of efficiency and also smooth running in both directions and a long service life. The fully machined casing with its many fixing bores and tapped holes permits mounting in any position.

The demand for an absolutely positive, and largely torsion-free connection between gear unit and output shaft, as it is especially important for intermittent operation, is fulfilled by our new gear-unit version with interface according to DIN EN ISO 9409-1-A as well as by our traditional version with shrink-disk coupling of the output shaft.

The drive, i.e. the connection with the driving motor, is achieved with a special clutch. Its internal gearing, together with the barrelled profile of the driving shaft of our worm gear unit ensures transmission of the power with no free play. The use of annular spring elements firmly fixed to the motor shaft serves the same purpose.

For the output drive you can choose from quite a number of output drive shafts with straight and helical tooth systems and various numbers of teeth. Apart from pinion shafts there is a multitude of gearwheels with different numbers of teeth from our gearwheel program which can be combined and used together with suitable special output drive shafts. In addition there is a large choice of gearwheels with helical tooth system for gear units with interface according to EN ISO 9409-1-A.

For emergency stops, the maximum transmittable torque of the gear unit (see page GA-11) and shrink disk (see page GH-1) has to be checked.



Mounting Instructions

Worm Gear Units

Five mounting faces with sufficiently dimensioned tapped holes are provided for mounting in any position. In order to accommodate all supplementary forces (see page GA-12) we recommend mounting at the largest contact faces., i.e. at one of the two cap sides. Putting the worm shaft (input shaft) in a lateral or inferior position is ideal for lubrication. Mounting the shaft in a top position will reduce the driving capacity by about 10%.

Coupling

The coupling will be delivered pre-assembled. Before attaching it to the motor shaft all contact surfaces must be cleaned and protected by applying a thin oil film. A retaining ring inserted in the hub of the coupling locks it on the motor shaft preventing axial movement of the coupling. It may be necessary to insert this ring in the next recess. Recommended sequence:

- Slide the coupling onto the motor shaft until it clicks home (shoulder/retaining ring).
- Tighten the clamping screws slightly and check the coupling for true running.
- Tighten screws alternately crosswise using torque figures as shown in operation and maintenance instructions ensuring that the gap between coupling and contact face remains even.
- A final check of true running is recommended at the applicable reference diameter!

A mounting guide can be found on page GI-1 to GI-4

Motor

Insert the motor with coupling mounted into the gear centering piece and bolt it to the gearbox.

Output Pinion Shaft

Unless the output pinion shaft comes already fully assembled, we recommend to proceed as follows:

Clean pinion shaft and hollow shaft extension and then oil them. For the special output drive shaft we recommend tolerance h6 (DIN ISO286). the material must have a minimum yield point of 385 N/mm².

A recalculation of the strength is necessary.

Output Drive Pinion for Interface EN ISO 9409-1-A

If the output pinion is not supplied already mounted, we recommend to proceed as follows:

Clean the pinion and the gearbox interface, put on the pinion and tighten the screws (crosswise) to the proper torque acc. to table (suitable screws 12.9 are supplied with the cylindrical gears).



Output Drive Shaft for Shrink-Disk Connection

Slide shrink disk onto the hollow shaft extension of the gear unit (please do not tighten the screws beforehand!). Insert the output shaft from the desired side into the hollow shaft fully up to the stop. Make the transverse pressure connection by evenly tightening the clamping screws. Tighten the screws one after the other (not crosswise) in several passes to the torque indicated in the operation and maintenance instructions.

Maintenance

Adjustment of Circumferential Backlash

The units are set up in the factory with a minimal amount of backlash. After prolonged usage, backlash may increase due to wear (reference value >15'). It can be adjusted by moving the eccentrically supported output shaft (= worm wheel).

We recommend to proceed as follows:

Unscrew the hexagon socket head screw of the two end caps without removing the caps in order to avoid oil leakage. Turn both caps towards the next higher number marked on the casing ensuring that they are both moved by the same amount. Check the backlash by turning the worm gear at least one complete revolution. If necessary, adjust further by another step. Evenly retighten the hexagon socket head screws alternately crosswise. An alteration of the gear center distance in relation to the overall operating conditions of the unit must be made up for by adjusting the attachment of the gear unit.

Lubricant Change

In the factory the gear units are filled with a synthetic lubricant and test run. They are delivered ready for use. A check of the lubricant level once a month - during the first weeks of operation more frequently - is recommended. Under normal load conditions and with single shift working it is recommended that the lubricant be changed every four years; with 2 or 3 shift working the lubricant should be changed annually. To do this, the unit must be emptied, flushed through and then refilled to the oil-level hole approximately in the middle of the gear unit using one of the lubricants recommended below. (Important: Synthetic lubricants must not be mixed with mineral oils.) For oil quantities see table.

Center Distance	Oil Quantity
a = 50 mm	0.3 l
a = 63 mm	0.5 l
a = 80 mm	1.2 l
a = 100 mm	2.0 l

We recommend the following synthetic gear lubricant:

Klübersynth GH 6 - 220
Order Code: 65 90 010 (1 liter)

Alternative:

SHELL Tivela S 220, BP Enersyn SG-XP 220, ARAL Degol GS 220

Degree to Protection

Degree of protection: IP65/67 according to ISO 20653
(Corrosion has to be verified separately).



	Page
HP High-Performance Gear Units with <2' Adjustable Backlash	GB2 – GB11
Center Distance 50 mm	GB2 – GB3
Center Distance 63 mm	GB4 – GB5
Center Distance 80 mm	GB6 – GB7
Center Distance 100 mm	GB8 – GB9
Center Distance 125 mm	GB10 – GB11
Couplings and Shrink-Disk	GB12
Selection and Load Tables	GB13 – GB15
Short Description	GB16
Mounting and Maintenance	GB17 – GB18
Gear Units Calculation and Selection	GF1 – GF3
Gear Units Accessories	GG1 – GG8
Motor Applications	GI1 – GI4





Center Distance

$a_o = 50 \text{ mm}$

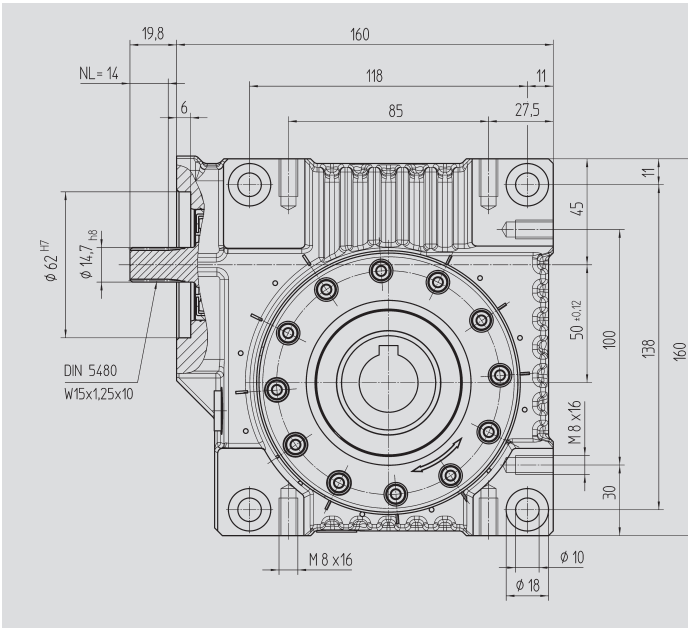

Fig. 1 Output shaft with key connection

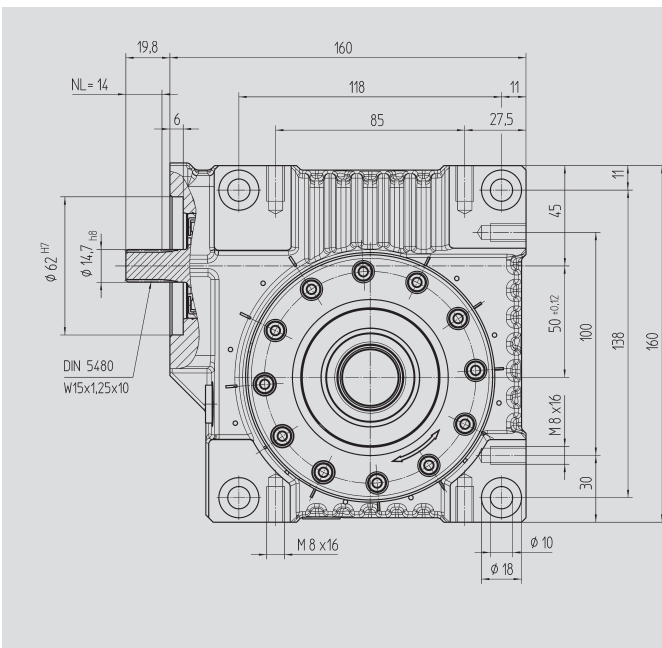

Fig. 2 Output shaft for clamp connection 80 83 030

Order Code Fig. 1	Fig. 2	Ratio i	kg	$J_{red} 10^{-4}$ kg m ²
58 03 005	58 13 005	4.75	6.5	0.8280
58 03 007	58 13 007	6.75	6.5	0.4140
58 03 009	58 13 009	9.25	6.5	0.3490
58 03 015	58 13 015	14.50	6.5	0.2800
58 03 020	58 13 020	19.50	6.5	0.1960
58 03 029	58 13 029	29.00	6.5	0.2694
58 03 039	58 13 039	39.00	6.5	0.2310
58 03 050	58 13 050	50.00	6.5	0.2140

With food grade oil, order code 58 03 1xx / 58 13 1xx

With ATEX version with food grade oil, order code 58 03 2xx / 58 13 2xx



Motor Flange

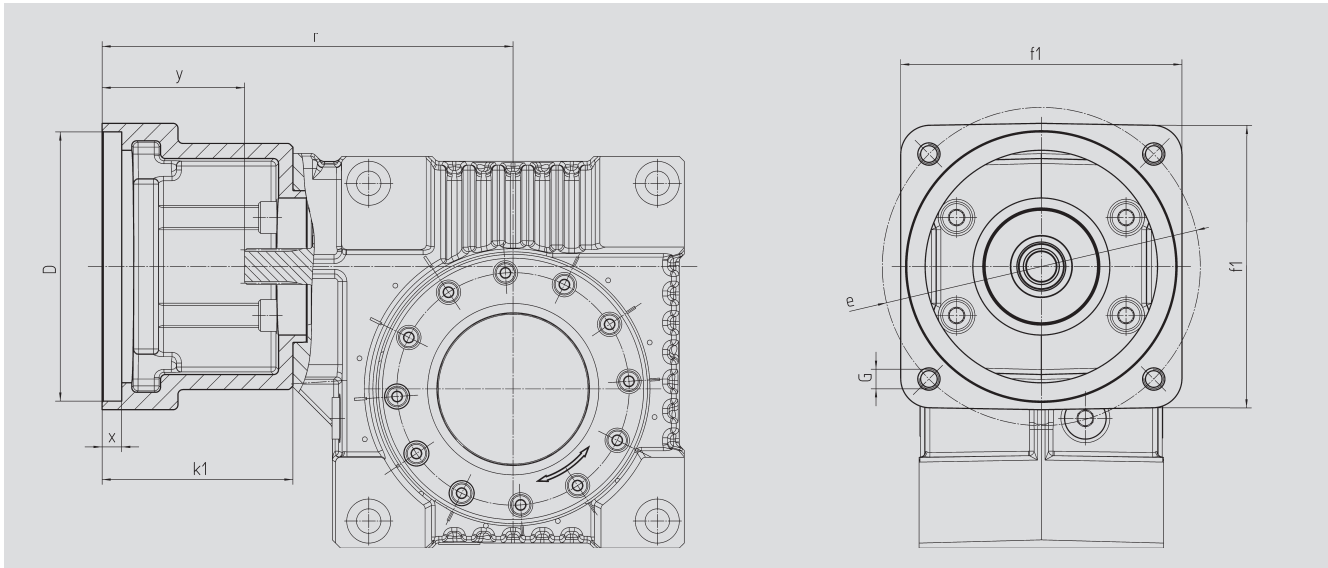

Center Distance

$a_o = 50 \text{ mm}$

Order Code	D ^{G7}	k ₁	r	x	y	f ₁	e	G	kg
65 59 301	95.0	62	152	12.5	42	100	115	M8	0.60
65 59 302	50.0	62	152	10.0	42	100	70, 95, 115	M4, M6, M8	0.70
65 59 303	80.0	62	152	10.0	42	100	100	M6	0.65
65 59 304	95.0	78	168	10.0	58	115	130	M8	0.80
65 59 305	95.0	72	162	8.0	52	100	115	M8	0.75
65 59 306	60.0	74	164	21.0	54	100	75, 90, 115	M5, M5, M8	0.90
65 59 307	70.0	70	160	21.0	50	100	90, 115	M6, M8	0.80
65 59 401	95.0	73	163	8.0	53	100	115	M8	0.75
65 59 402	110.0	78	168	8.0	58	115	130	M8	0.80
65 59 403	95.0	73	163	12.0	53	115	130	M8	0.75
65 59 404	110.0	73	163	12.0	53	115	130	M8	0.70
65 59 405	95.0	78	168	11.0	58	140	165	M10	1.20
65 59 406	110.0	78	168	11.0	58	140	165	M10	1.15
65 59 407	130.0	78	168	11.0	58	140	165	M10	1.00
65 59 409	130.0	98	188	14.0	78	140	165	M10	1.10
65 59 410	110.0	74	164	8.0	54	120	145	M8	1.00
65 59 411	110.0	84	174	8.0	64	120	145	M8	1.20
65 59 412	114.3	105	195	8.0	85	180	200	M12	3.70
65 59 413	114.3	139	229	8.0	119	180	200	M12	3.35
65 59 414	114.3	91	181	8.0	71	180	200	M12	2.65
65 59 415	110.0	89	179	8.0	69	120	145	M8	1.30

The order should contain gear box 58 03 0xx / 58 13 0xx and flange 65 59 3xx or 4xx.



Center Distance

$$a_o = 63 \text{ mm}$$

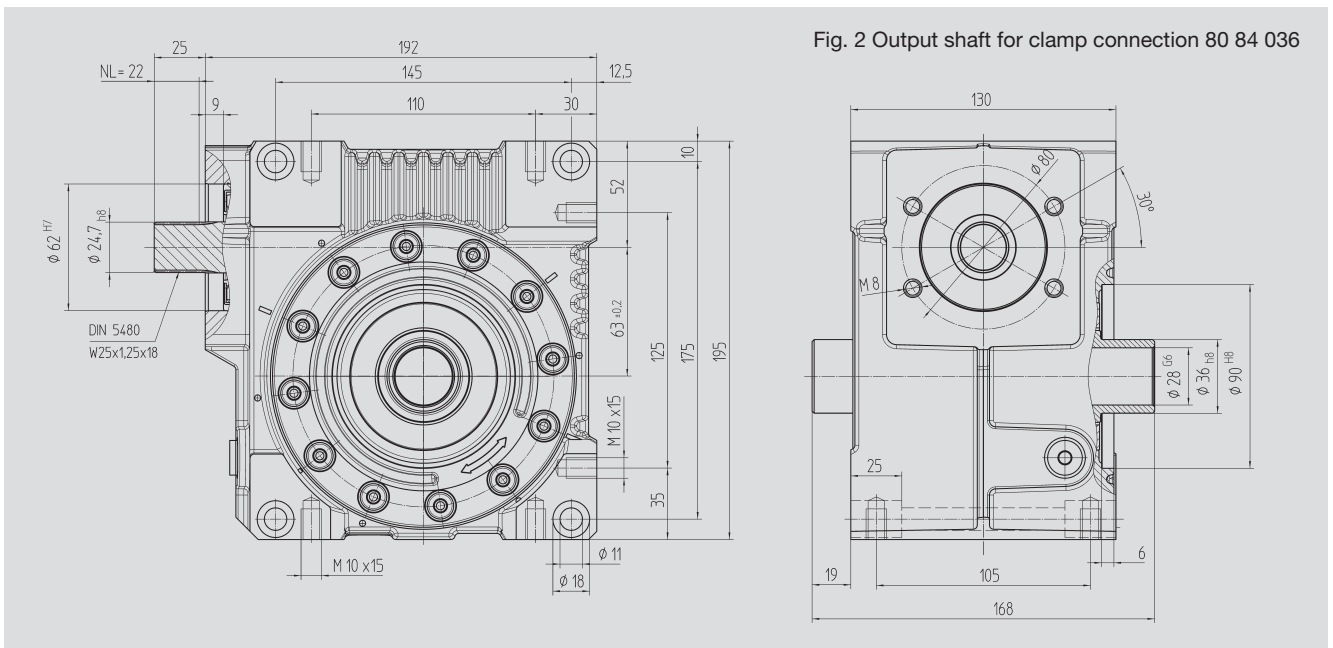
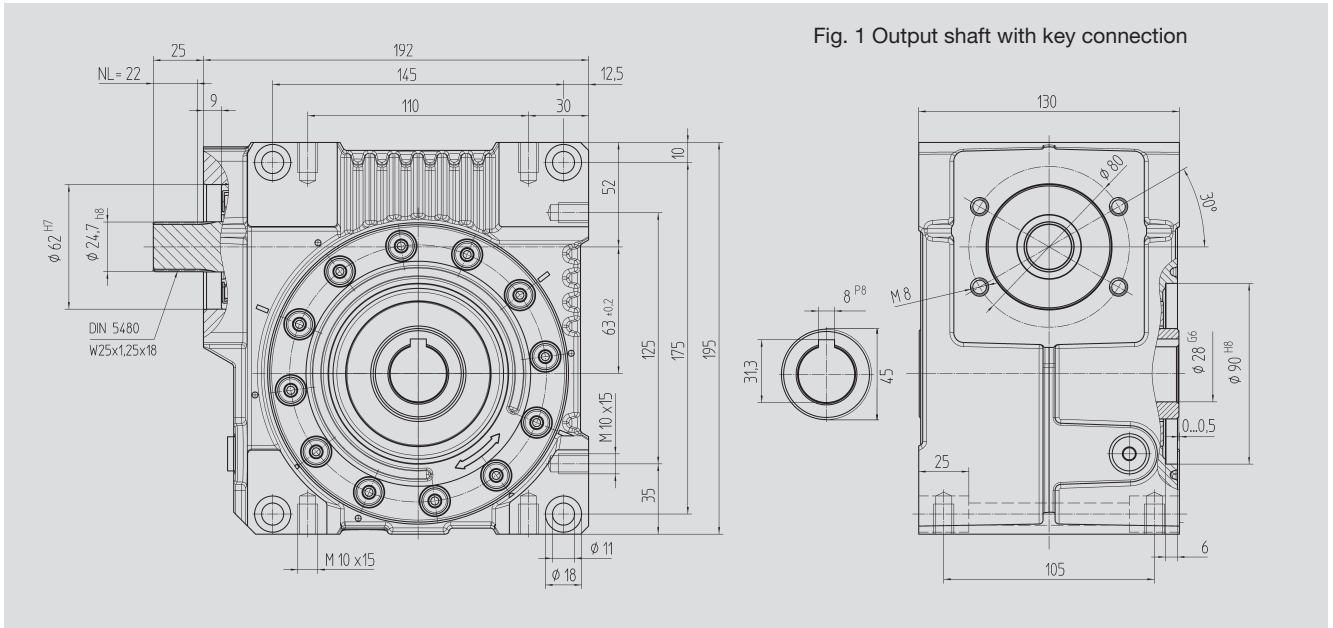

Order Code Fig. 1	Fig. 2	Ratio i	kg	J _{red} 10 ⁻⁴ kg m ²
58 04 005	58 14 005	4.75	11.5	2.5350
58 04 007	58 14 007	6.75	11.5	1.3720
58 04 009	58 14 009	9.25	11.5	0.9825
58 04 015	58 14 015	14.50	11.5	0.9590
58 04 020	58 14 020	19.50	11.5	0.6940
58 04 029	58 14 029	29.00	11.5	0.9966
58 04 039	58 14 039	39.00	11.5	1.0100
58 04 052	58 14 052	52.00	11.5	0.5305

With food grade oil, order code 58 04 1xx / 58 14 1xx

With ATEX version with food grade oil, order code 58 04 2xx / 58 14 2xx



Motor Flange

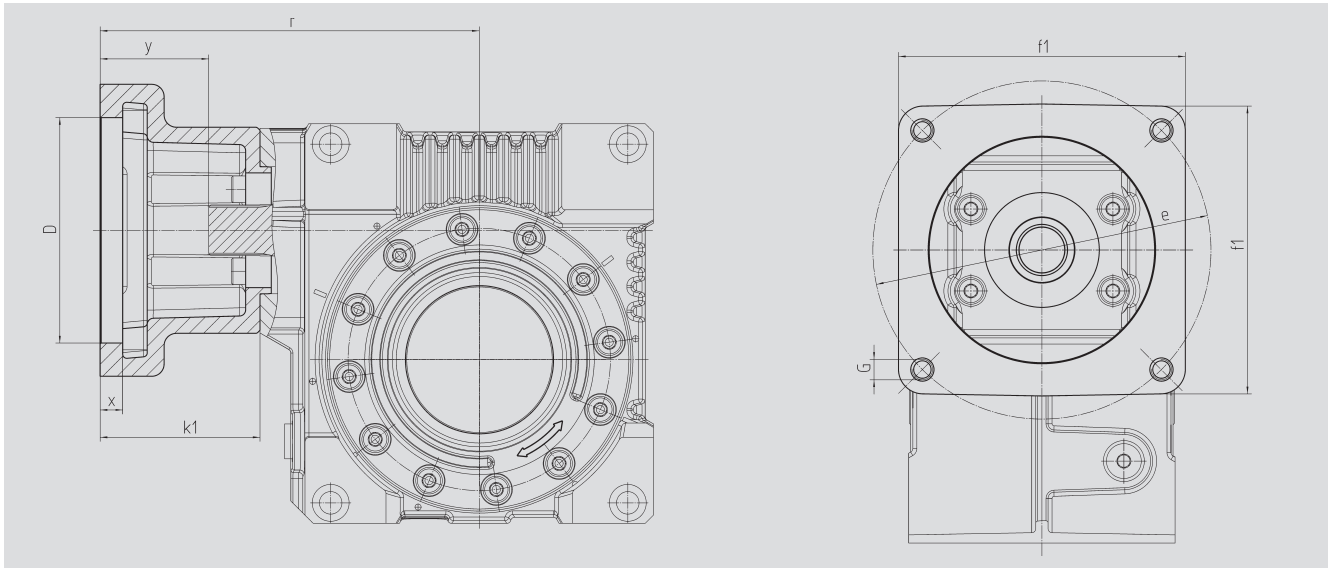

Center Distance

$a_o = 63 \text{ mm}$

Order Code	D ^{G7}	k ₁	r	x	y	f ₁	e	G	 kg
65 59 301	95.0	62	169	12.5	37	100	115	M8	0.60
65 59 302	50.0	62	169	10.0	37	100	70, 95, 115	M4, M6, M8	0.70
65 59 303	80.0	62	169	10.0	37	100	100	M6	0.65
65 59 304	95.0	78	185	10.0	53	115	130	M8	0.80
65 59 305	95.0	72	179	8.0	47	100	115	M8	0.75
65 59 306	60.0	74	181	21.0	49	100	75, 90, 115	M5, M5, M8	0.90
65 59 307	70.0	70	177	21.0	45	100	90, 115	M6, M8	0.80
65 59 401	95.0	73	180	8.0	48	100	115	M8	0.75
65 59 402	110.0	78	185	8.0	53	115	130	M8	0.80
65 59 403	95.0	73	180	12.0	48	115	130	M8	0.75
65 59 404	110.0	73	180	12.0	48	115	130	M8	0.70
65 59 405	95.0	78	185	11.0	53	140	165	M10	1.20
65 59 406	110.0	78	185	11.0	53	140	165	M10	1.15
65 59 407	130.0	78	185	11.0	53	140	165	M10	1.00
65 59 409	130.0	98	205	14.0	73	140	165	M10	1.10
65 59 410	110.0	74	181	8.0	49	120	145	M8	1.00
65 59 411	110.0	84	191	8.0	59	120	145	M8	1.20
65 59 412	114.3	105	212	8.0	80	180	200	M12	3.70
65 59 413	114.3	139	246	8.0	114	180	200	M12	3.35
65 59 414	114.3	91	198	8.0	66	180	200	M12	2.65
65 59 415	110.0	89	196	8.0	64	120	145	M8	1.30

The order should contain gear box 58 04 0xx / 58 14 0xx and flange 65 59 3xx or 4xx.



Center Distance

$a_o = 80 \text{ mm}$

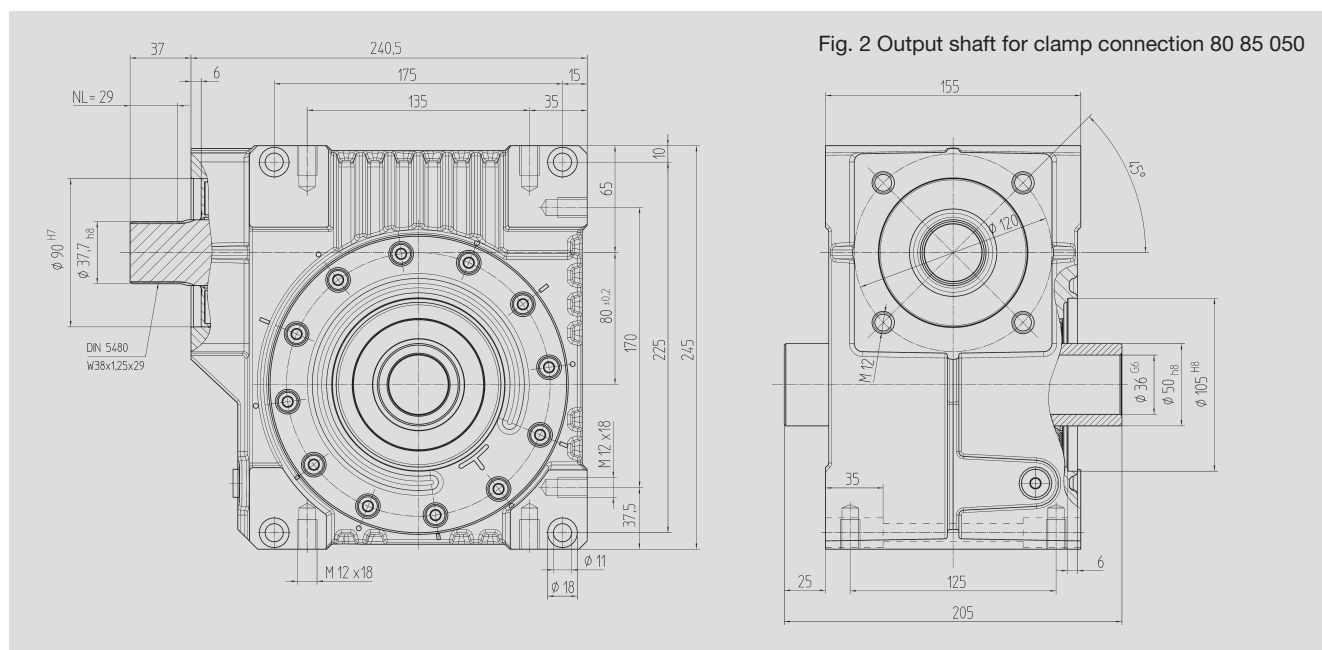
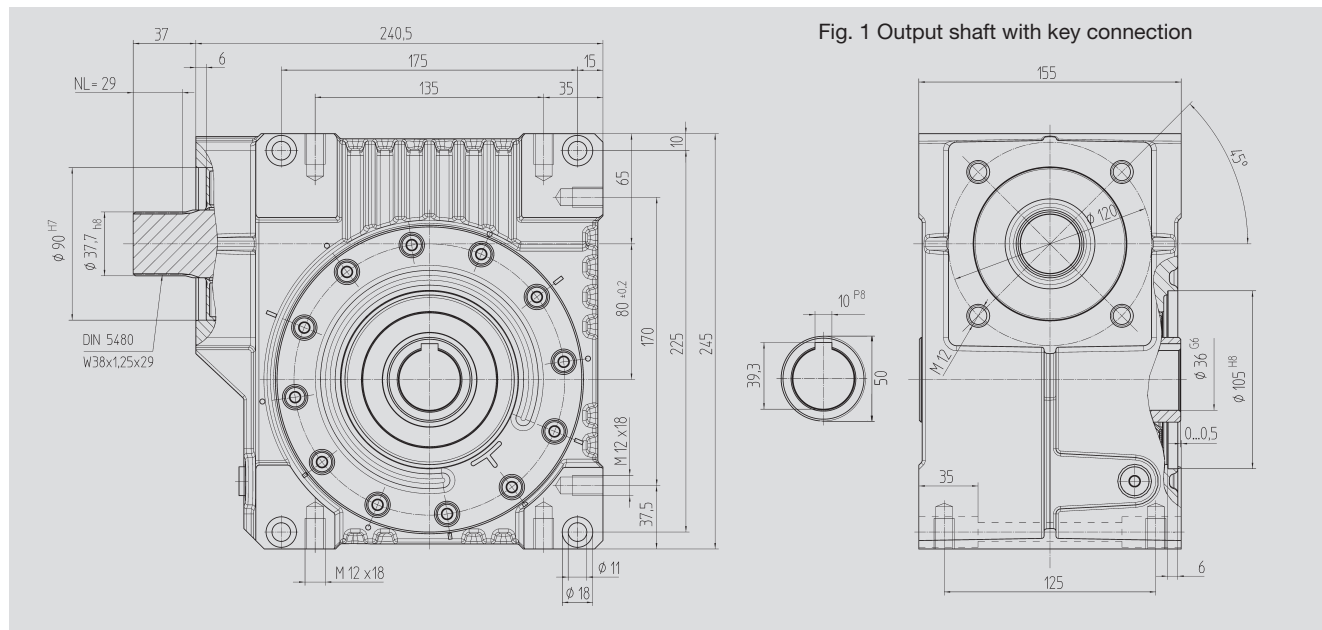

Order Code Fig. 1	Fig. 2	Ratio i	J_{red} kg	$J_{red} 10^{-4}$ kg m ²
58 05 005	58 15 005	4.75	22	9.6180
58 05 007	58 15 007	6.75	22	6.0910
58 05 009	58 15 009	9.25	22	4.7650
58 05 015	58 15 015	14.50	22	5.3080
58 05 020	58 15 020	19.50	22	3.9350
58 05 029	58 15 029	29.00	22	4.0500
58 05 039	58 15 039	39.00	22	4.1800
58 05 052	58 15 052	52.00	22	3.7140

With food grade oil, order code 58 05 1xx / 58 15 1xx

With ATEX version with food grade oil, order code 58 05 2xx / 58 15 2xx



Motor Flange

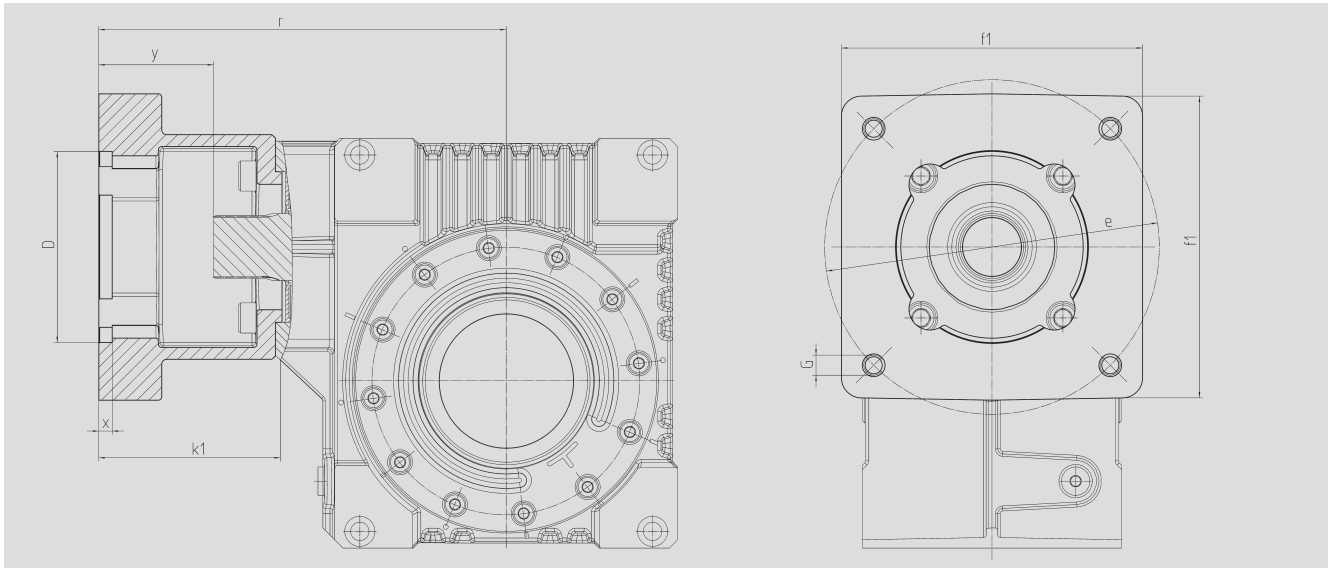

Center Distance

$a_o = 80 \text{ mm}$

Order Code	D ^{G7}	k ₁	r	x	y	f ₁	e	G	kg
65 59 501	110.0	92.0	230.0	8.0	55.0	140	165	M10	2.00
65 59 502	130.0	92.0	230.0	8.0	55.0	140	165	M10	1.90
65 59 503	180.0	122.0	260.0	8.0	85.0	192	215	M12	3.40
65 59 504	180.0	127.0	265.0	8.0	90.0	192	215	M12	3.80
65 59 505	180.0	112.0	250.0	10.0	75.0	192	215	M12	2.70
65 59 506	130.0	112.0	250.0	10.0	75.0	192	215	M12	3.00
65 59 507	130.0	112.0	250.0	10.0	75.0	140	165	M10	2.50
65 59 508	110.0	90.0	228.0	8.0	53.0	140	145	M8	2.00
65 59 509	110.0	108.5	246.5	8.0	71.5	140	145	M8	2.50
65 59 510	114.3	129.5	267.5	8.0	92.5	180	200	M12	5.00
65 59 511	114.3	163.5	301.5	8.0	126.5	180	200	M12	4.20
65 59 512	114.3	105.5	243.5	8.0	68.5	180	200	M12	3.50
65 59 513	110.0	113.5	251.5	8.0	76.5	140	145	M8	2.70

The order should contain gear box 58 05 0xx / 58 15 0xx and flange 65 59 5xx.



Center Distance

$a_o = 100 \text{ mm}$

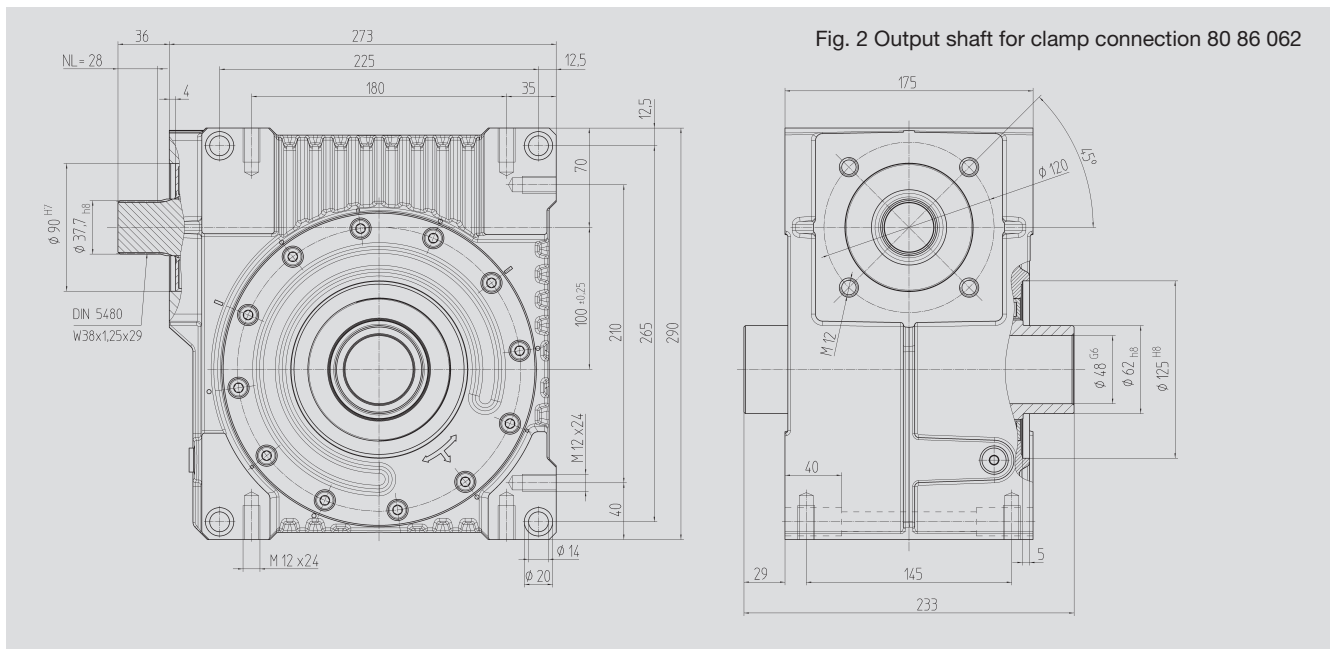
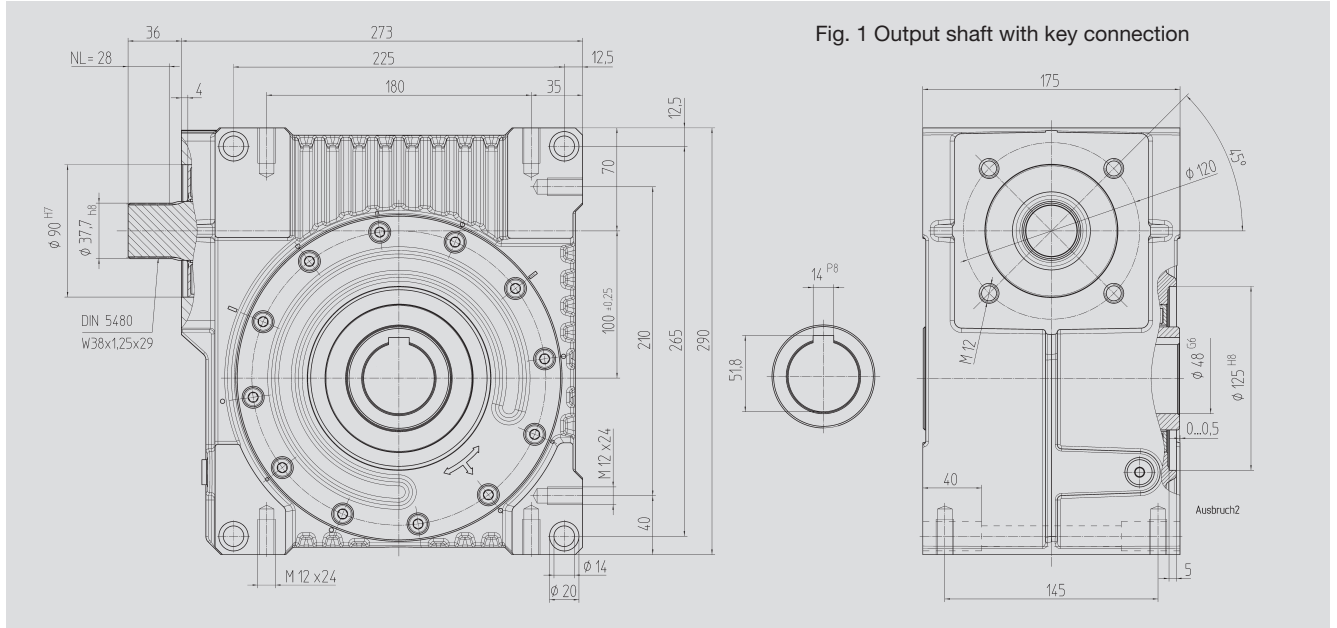

Order Code Fig. 1	Fig. 2	Ratio i	kg	J_{red} 10 ⁻⁴ kg m ²
58 06 005	58 16 005	4.75	37	22.9320
58 06 007	58 16 007	6.75	37	12.8835
58 06 009	58 16 009	9.25	37	8.0975
58 06 015	58 16 015	14.50	37	7.2190
58 06 020	58 16 020	19.50	37	5.4030
58 06 029	58 16 029	29.00	37	4.7207
58 06 039	58 16 039	39.00	37	8.4300
58 06 052	58 16 052	52.00	37	9.7400

With food grade oil, order code 58 06 1xx / 58 16 1xx

With ATEX version with food grade oil, order code 58 06 2xx / 58 16 2xx



Motor Flange

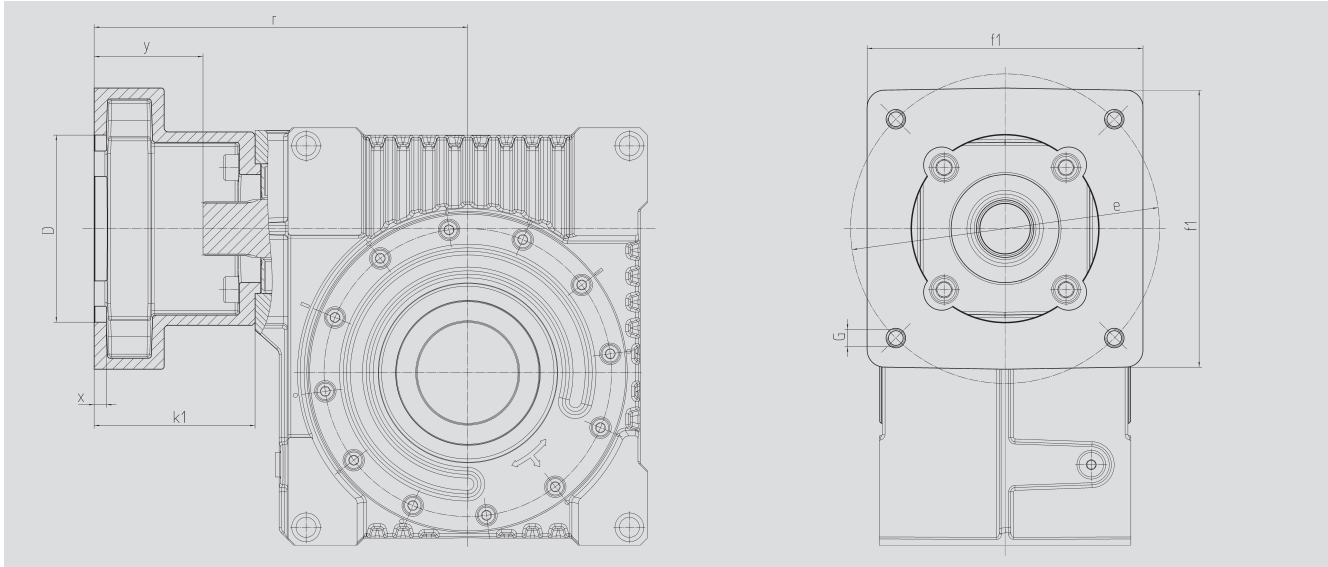

Center Distance

$a_o = 100 \text{ mm}$

Order Code	D ^{G7}	k ₁	r	x	y	f ₁	e	G	 kg
65 59 501	110.0	92.0	240.0	8.0	55.0	140	165	M10	2.00
65 59 502	130.0	92.0	240.0	8.0	55.0	140	165	M10	1.90
65 59 503	180.0	122.0	270.0	8.0	85.0	192	215	M12	3.40
65 59 504	180.0	127.0	275.0	8.0	90.0	192	215	M12	3.80
65 59 505	180.0	112.0	260.0	10.0	75.0	192	215	M12	2.70
65 59 506	130.0	112.0	260.0	10.0	75.0	192	215	M12	3.00
65 59 507	130.0	112.0	260.0	10.0	75.0	140	165	M10	2.50
65 59 508	110.0	90.0	238.0	8.0	53.0	140	145	M8	2.00
65 59 509	110.0	108.5	256.5	8.0	71.5	140	145	M8	2.50
65 59 510	114.3	129.5	277.5	8.0	92.5	180	200	M12	5.00
65 59 511	114.3	163.5	311.5	8.0	126.5	180	200	M12	4.20
65 59 512	114.3	105.5	253.5	8.0	68.5	180	200	M12	3.50
65 59 513	110.0	113.5	261.5	8.0	76.5	140	145	M8	2.70

The order should contain gear box 58 06 0xx / 58 16 0xx and flange 65 59 5xx.



Center Distance

$a_0 = 125 \text{ mm}$

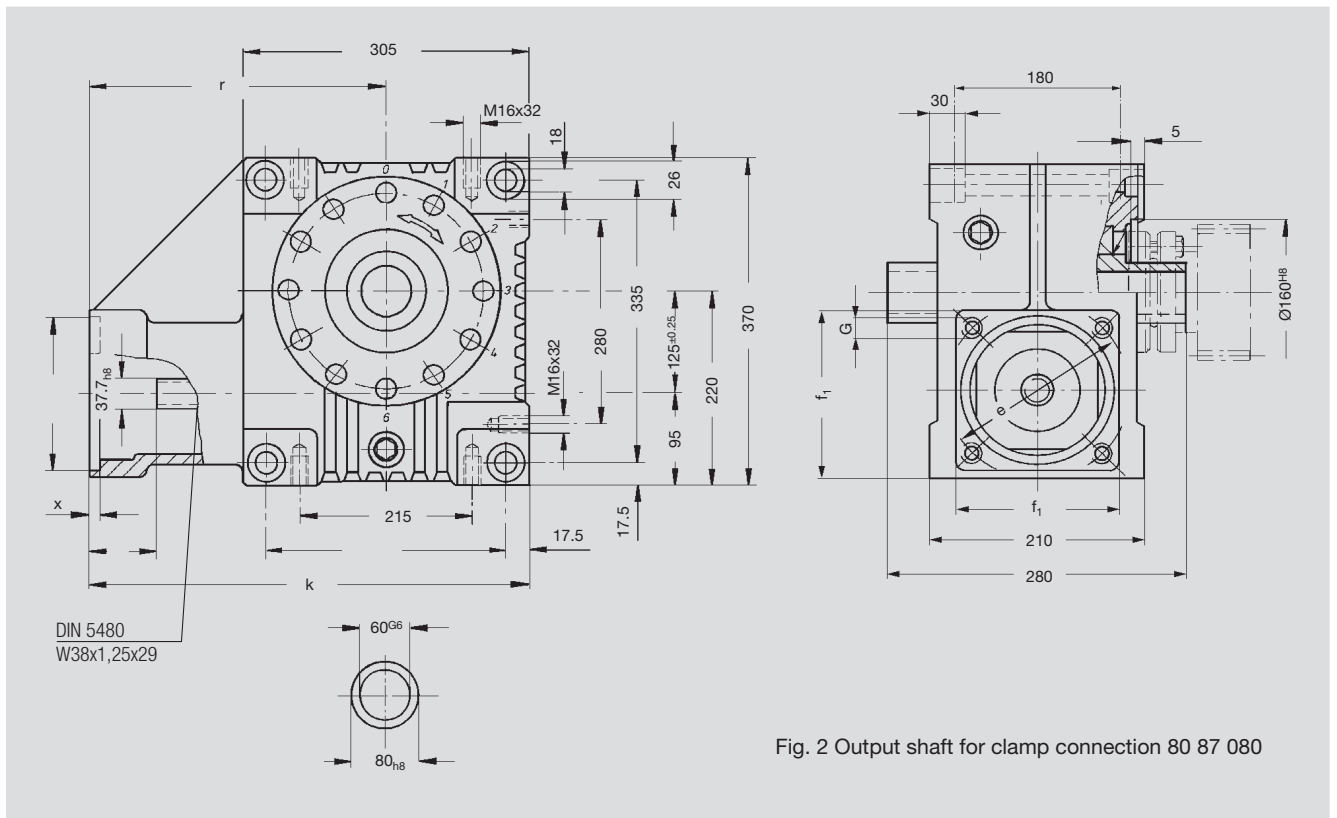
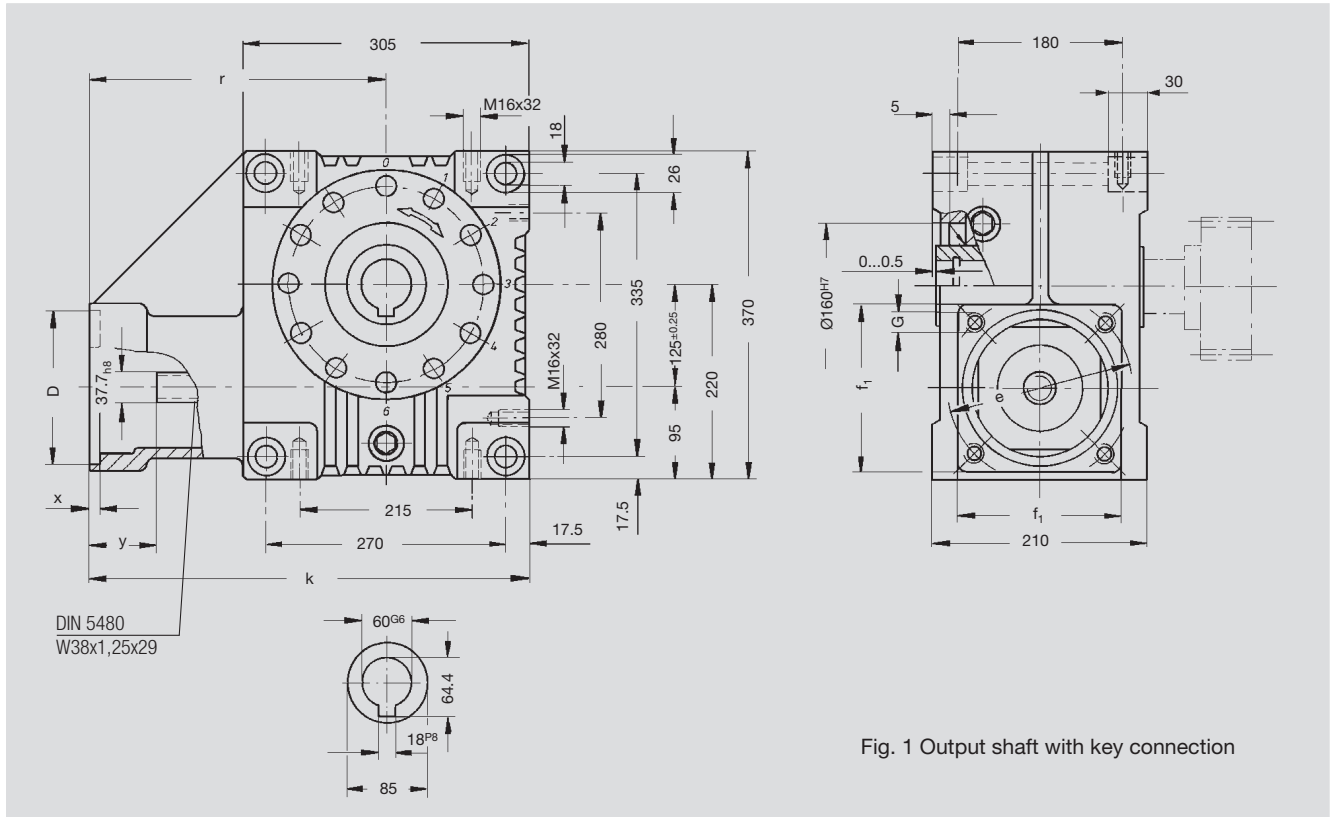

**Center Distance** **$a_o = 125 \text{ mm}$**

Order Code Fig.1	Fig. 2	Ratio i	D^{G7}	k	r	x	y	f_1	e	G	 kg	J_{red} 10^{-4} kg m^2
58 47 007	58 87 007	6.75										35.9192
58 47 009	58 87 009	9.25										23.3256
58 47 015	58 87 015	14.50	180	468	315.5	6	75	200	215	M12	68	25.5742
58 47 020	58 87 020	19.50										16.4748
58 47 029	58 87 029	29.00										23.4384
58 47 039	58 87 039	39.00										15.3588
58 47 052	58 87 052	52.00										11.2943
58 47 107	58 87 107	6.75										35.9192
58 47 109	58 87 109	9.25										23.3256
58 47 115	58 87 115	14.50	180	484	331.5	6	91	200	215	M12	68	25.5742
58 47 120	58 87 120	19.50										16.4748
58 47 129	58 87 129	29.00										23.4384
58 47 139	58 87 139	39.00										15.3588
58 47 152	58 87 152	52.00										11.2943



Other center distances and ratios available on request.



Special Couplings for Motor/Gear Units, rigid model, nitrided, preassembled for motor shafts without key



Bore on gear unit side
low-clearance tooth-hub
profile corresponding to
DIN 5480 for push-fitting

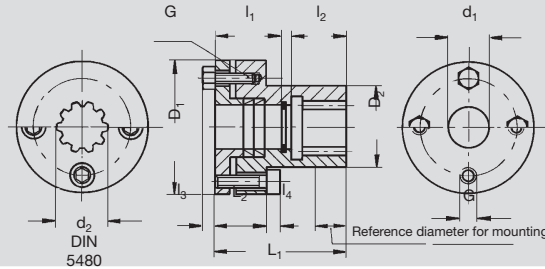

Bore on motor side with
locking elements as clamp
connection

Order Code

Coupling	1)	d ₁	d ₂	D ₁	D ₂	l ₁	l ₂	l ₃	l ₄	L ₁	L ₂	G	J _{red} 10 ⁻⁴ kg m ²	kg
65 43 110	9 71 80 010	10	15x1.25x10	48	29	22	17	-	5	44	18	4xM5	0.835	0.40
65 43 111	9 71 80 011	11	15x1.25x10	48	29	20.5	17	-	5	64	18	4xM5	0.976	0.50
65 43 114	9 71 80 014	14	15x1.25x10	48	29	24	19	-	5	50	18	4xM5	0.835	0.45
65 43 116	9 71 80 016	16	15x1.25x10	48	29	27	16	-	5	50	18	4xM5	0.824	0.45
65 43 119	9 71 80 019	19	15x1.25x10	48	29	24	16	-	5	40	18	4xM5	0.799	0.40
65 43 914	9 71 80 014	14	15x1.25x10	48	29	26	19	-	5	64	18	4xM5	0.985	0.50
65 43 916	9 71 80 016	16	15x1.25x10	48	29	27	15	-	5	64.3	18.3	4xM5	0.975	0.40
65 43 919	9 71 80 019	19	15x1.25x10	48	29	23	17	-	5	55	18	4xM5	0.853	0.45
65 43 924	9 71 80 024	24	15x1.25x10	50	29	34	22	-	6	56	40	4xM6	1.041	0.52
65 44 024	9 71 80 024	24	25x1.25x18	50	29	41.5	24	-	6	66.5	59.5	4xM6	2.628	0.75
65 44 114	9 71 80 014	14	25x1.25x18	55	32	24	23.5	-	6	64	21	4xM6	1.645	0.50
65 44 116	9 71 80 016	16	25x1.25x18	55	32	34	23.5	-	6	64	21	4xM6	1.622	0.50
65 44 119	9 71 80 019	19	25x1.25x18	55	32	33	26.5	-	6	63	21	4xM6	1.598	0.50
65 44 120	9 71 80 020	20	25x1.25x18	55	32	33.2	26.5	-	6	63	21	4xM6	1.550	0.50
65 44 219	9 71 80 019	19	25x1.25x18	55	32	27	26.5	-	6	74	21	4xM6	1.703	0.50
65 44 919	9 71 80 019	19	25x1.25x18	55	32	31	26.5	-	6	78	21	4xM6	1.757	0.55
65 44 928	9 71 80 028	28	25x1.25x18	70	48	48	26	-	6	83	25	5xM6	5.998	0.85
65 44 932	9 71 80 032	32	25x1.25x18	70	48	43	23	-	6	78	25	5xM6	5.921	0.80
65 44 935	9 71 81 035	35	25x1.25x18	70	48	52	26	-	6	78	25	5xM6	6.155	0.95
65 46 024	9 71 80 024	24	38x1.25x29	55	-	38.5	31	4	6	72.5	-	5xM6	4.452	0.90
65 46 834	9 71 81 035	1 3/8"	38x1.25x29	80	58	63	34	-	6	100	40	6xM6	16.320	1.95
65 46 928	9 71 80 028	28	38x1.25x29	70	48	47	34	-	6	90	25	5xM6	5.882	0.90
65 46 932	9 71 80 032	32	38x1.25x29	70	48	43	34	-	6	86	25	5xM6	5.784	0.85
65 46 935	9 71 81 035	35	38x1.25x29	80	58	65	34	-	6	100	40	6xM6	16.550	1.95
65 46 938	9 71 80 038	38	38x1.25x29	80	58	62	34	-	6	100	40	6xM6	16.240	1.88
65 47 948	9 71 80 048	48	38x1.25x29	95	66	58	31	-	8	92	42	6xM8	41.860	3.10

1) Spare part clamping element

Shrink-Disk Clamping Sets for Output Drive Shafts of gear series 58 1. ...

Supplied as
complete set

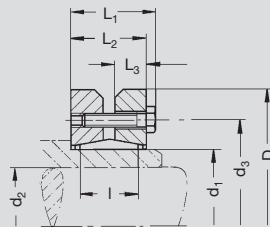

$$J_{red} = \frac{J}{i^2}$$

Order Code	a ₀ mm	T _{2,max} Nm	d ₁	d ₂	d ₃	D	L ₁	L ₂	L ₃	l	G	J 10 ⁻⁴ kg m ²	kg
80 83 030	50	400	30	25	44	60	25.0	21.50	9	16	7 x M5	1.756	0.3
80 84 036	63	540	36	28	52	72	27.5	23.50	10	18	5 x M6	4.029	0.4
80 85 050	80	1180	50	36	70	90	31.5	27.50	12	22	9 x M6	11.322	0.8
80 86 062	100	2300	62	48	86	110	34.5	30.50	13	23	12 x M6	27.137	1.3
80 87 080	125	3240	80	60	100	145	38.0	32.50	14	25	7 x M8	88.870	1.9



Gearing efficiency of servo worm gear units with driving worm and under full load.

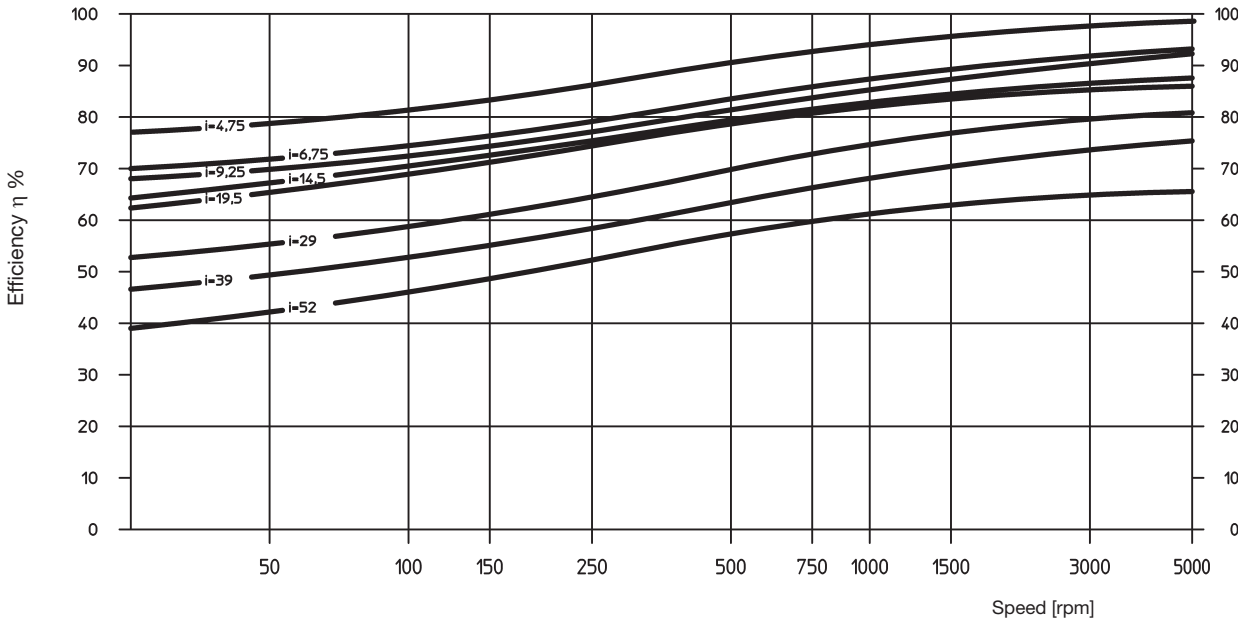

Additional loads on output drive

The data given are reference values. You should consider the values arising from the choice of the tooth system. It is assumed that the point of action of the force is the center of the shaft. In cases where additional axial forces occur, over and above high transverse forces, please ask for advice.

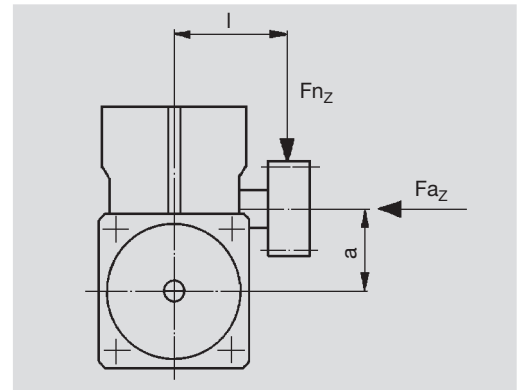

Center Distance a (mm)	50		63		80		100		125	
Dimension center of casing to center of pinion										
l (mm)	90	140	110	160	125	175	140	190	175	220
Max. additional load										
radial F_{n_z} [N]	3600	2300	5000	3500	8400	6000	10000	7500	21000	16000
axial F_{a_z} [N]	1800	1800	2500	2500	4000	4000	5000	5000	10000	10000
Only axial load ($F_n = 0$)										
F_{a_z} [N]	3000		5000		12000		15000		25000	



The values in the tables are based upon wear or maximum flank load at 12,000 hours full load and on servo-operation. With continuous full-load operation it may be necessary to consider temperature limits! (Please ask us if in doubt.)

$T_{2max.}$ = static torque to avoid tooth fracture. T_1 = input torque in Nm. T_2 = output torque in Nm.



Order Code	a_0 (mm)	i	$T_{2max.}$	Input Speed n_1 (rpm)													
				250		500		750		1000		1500		2000			
				T_1 (Nm)	T_2 (Nm)	T_1 (Nm)	T_2 (Nm)	T_1 (Nm)	T_2 (Nm)	T_1 (Nm)	T_2 (Nm)	T_1 (Nm)	T_2 (Nm)	T_1 (Nm)	T_2 (Nm)		
58 03 003 58 13 003	50	3.00*															
58 03 005 58 13 005		4.75	550	11.6	48	15.1	65	15.1	65	16.3	70	16.4	70	16.5	70		
58 03 007 58 13 007		6.75	400	7.2	42	9.4	56	9.9	59	10.5	63	11.4	69	11.4	69		
58 03 009 58 13 009		9.25	275	4.8	35	6.3	48	6.5	51	6.9	54	7.4	58	7.9	62		
58 03 015 58 13 015		14.50	350	3.7	42	4.8	57	5.0	60	5.3	65	5.8	70	5.9	72		
58 03 020 58 13 020		19.50	250	2.4	33	3.1	45	3.3	48	3.4	50	3.7	55	3.9	58		
58 03 029 58 13 029		29.00	300	1.9	36	2.4	48	2.6	52	2.7	55	2.9	60	3.1	63		
58 03 039 58 13 039		39.00	200	1.8	39	2.3	52	2.4	56	2.5	60	2.7	65	2.8	68		
58 03 050 58 13 050		50.00	150	1.5	31	1.9	42	1.9	44	2.0	47	2.1	50	2.2	53		
58 04 003 58 14 003	63	3.00*															
58 04 005 58 14 005		4.75	1000	37.6	163	38.9	170	41.2	180	41.3	180	39.2	170	37.4	162		
58 04 007 58 14 007		6.75	750	21.5	129	27.9	170	29.4	180	29.4	180	27.9	170	26.6	162		
58 04 009 58 14 009		9.25	500	10.8	85	14.2	115	15.3	125	15.9	130	16.4	135	16.4	135		
58 04 015 58 14 015		14.50	600	11.1	132	13.6	165	14.7	180	14.7	180	14.7	180	14.5	177		
58 04 020 58 14 020		19.50	500	5.6	87	7.2	115	7.7	125	8.0	130	8.3	135	9.0	145		
58 04 029 58 14 029		29.00	650	6.9	137	8.4	175	9.1	190	9.7	205	10.5	220	10.1	212		
58 04 039 58 14 039		39.00	450	4.2	106	5.2	140	5.5	150	5.8	160	6.4	175	6.6	180		
58 04 052 58 14 052		52.00	300	2.4	71	3.0	95	3.3	105	3.5	115	3.8	125	4.0	133		
58 05 003 58 15 003	80	3.00*															
58 05 005 58 15 005		4.75	2000	102.9	453	94.9	420	85.9	380	81.5	360	75.0	330	71.5	313		
58 05 007 58 15 007		6.75	1400	65.2	402	67.6	420	61.1	380	57.8	360	53.2	330	50.7	313		
58 05 009 58 15 009		9.25	1100	37.5	310	44.2	370	44.1	370	42.9	360	39.3	330	37.5	313		
58 05 015 58 15 015		14.50	1300	34.9	431	35.9	450	35.8	450	33.4	420	29.4	370	27.5	345		
58 05 020 58 15 020		19.50	1000	21.9	353	22.5	370	24.2	400	24.1	400	21.7	360	20.9	347		
58 05 029 58 15 029		29.00	1200	22.9	498	23.3	520	24.5	550	23.6	530	21.8	490	20.8	467		
58 05 039 58 15 039		39.00	850	15.0	412	15.1	430	16.0	460	17.0	490	16.7	480	15.9	457		
58 05 052 58 15 052		52.00	600	6.3	216	6.6	240	7.1	260	7.5	275	8.2	300	8.5	310		
58 06 005 58 16 005	100	4.75	3300	234.2	1043	197.3	880	179.6	800	169.1	750	154.3	685	147.1	650		
58 06 007 58 16 007		6.75	2300	127.2	797	131.8	830	119.1	750	114.8	720	105.3	660	101.3	633		
58 06 009 58 16 009		9.25	1900	94.3	794	97.6	830	88.1	750	84.8	720	77.7	660	74.8	633		
58 06 015 58 16 015		14.50	2050	70.0	892	72.2	930	68.2	880	62.9	810	55.9	720	53.5	687		
58 06 020 58 16 020		19.50	1800	51.8	861	53.3	900	51.3	870	47.8	810	42.5	720	40.6	687		
58 06 029 58 16 029		29.00	2300	48.7	1103	49.9	1150	46.1	1070	43.7	1010	36.8	850	36.2	833		
58 06 039 58 16 039		39.00	1650	35.2	1034	35.8	1080	34.0	1030	33.0	1000	29.7	900	28.5	860		
58 06 052 58 16 052		52.00	1100	20.7	759	20.0	760	21.5	820	22.3	850	20.6	785	19.7	750		
58 47 _07 58 87 _07	125	6.75	6450	287.3	1815	260.3	1650	236.7	1500	221.1	1400	206.0	1300	198.7	1250		
58 47 _09 58 87 _09		9.25	4400	179.3	1534	186.0	1600	168.4	1450	156.9	1350	139.8	1200	134.3	1150		
58 47 _15 58 87 _15		14.50	5850	145.3	1874	138.7	1800	127.0	1650	134.8	1750	115.8	1500	111.1	1433		
58 47 _20 58 87 _20		19.50	3900	106.5	1825	101.1	1750	92.2	1600	86.3	1500	80.8	1400	77.1	1333		
58 47 _29 58 87 _29		29.00	5700	98.0	2290	93.0	2200	86.4	2050	82.2	1950	76.3	1800	73.0	1717		
58 47 _39 58 87 _39		39.00	3800	71.6	2190	67.5	2100	62.4	1950	59.2	1850	54.6	1700	52.7	1633		
58 47 _52 58 87 _52		52.00	2500	46.2	1801	45.0	1800	42.3	1700	39.8	1600	37.4	1500	35.8	1433		

* On request



Input Speed n_1 (rpm)															
2500		3000		3500		4000		4500		5000		5500		6000	
T_1 (Nm)	T_2 (Nm)	T_1 (Nm)	T_2 (Nm)	T_1 (Nm)	T_2 (Nm)	T_1 (Nm)	T_2 (Nm)	T_1 (Nm)	T_2 (Nm)	T_1 (Nm)	T_2 (Nm)	T_1 (Nm)	T_2 (Nm)	T_1 (Nm)	T_2 (Nm)
25.0	70	16.8	70	16.3	67	15.8	65	15.5	63	15.1	61	14.3	57	13.6	53
17.2	69	11.6	69	11.3	67	11.0	65	10.7	63	10.5	61	9.9	57	9.4	54
12.6	66	8.9	70	8.9	70	8.9	70	8.7	67	8.4	65	8.0	61	7.6	58
9.1	73	6.2	75	6.2	75	6.3	75	6.3	75	6.4	75	6.1	70	5.8	67
6.1	61	4.3	65	4.3	65	4.3	65	4.3	65	4.4	65	4.2	61	4.0	58
4.9	67	3.5	70	3.5	70	3.5	70	3.4	67	3.3	65	3.2	61	3.0	57
4.4	71	3.1	75	3.1	75	3.1	75	3.1	75	3.1	75	3.0	70	2.9	66
3.4	57	2.4	60	2.4	60	2.4	60	2.4	60	2.4	60	2.5	62	2.5	64
53.4	153	34.0	145	32.9	140	31.9	135	29.6	124	27.5	115				
38.1	153	24.1	145	23.4	140	22.7	135	21.1	125	19.8	116	18.6	109		
24.6	135	16.5	135	16.0	130	15.6	126	14.6	117	13.8	110	13.0	104	12.4	98
21.4	173	14.1	170	13.7	165	13.4	160	12.5	148	11.7	138	11.1	130		
14.4	155	10.3	165	9.9	160	9.7	155	9.1	144	8.6	136	8.2	128	7.8	121
14.6	203	9.4	195	9.3	190	9.1	185	8.5	171	8.0	159	7.6	149		
10.2	185	7.0	190	7.0	190	7.1	190	6.7	177	6.3	166	6.0	156	5.7	148
6.5	142	4.6	150	4.8	155	5.0	160	4.8	155	4.6	145	4.4	137	4.2	129
102.2	297	64.6	280	58.9	254	53.2	228								
72.4	297	45.7	280	42.0	256	38.2	232	35.3	213	32.9	198				
53.5	297	33.8	280	31.2	257	28.5	234	26.6	217	24.8	202	23.3	189		
38.5	320	23.8	295	21.9	270	20.0	245	18.5	226	17.3	210				
30.3	333	19.5	320	18.0	295	16.6	269	15.4	250	14.5	233	13.6	218		
29.9	443	19.0	420	17.5	384	16.0	348	14.9	322						
22.8	433	14.5	410	13.4	377	12.4	345	11.5	319	10.8	297	10.2	278		
13.2	320	9.1	330	9.1	330	9.2	330	8.6	308	8.2	288	7.8	271		
209.5	615	132.3	580												
146.1	607	93.5	580	84.3	521	69.2	426								
107.9	607	69.0	580	62.9	526	52.2	436	53.2	442	49.6	410				
76.6	653	48.6	620	44.0	559	40.2	509								
58.2	653	37.0	620	33.7	564	31.1	516	28.8	477	26.8	442				
53.6	817	35.2	800	31.9	721										
41.0	820	26.1	780	23.9	708	19.9	587	20.4	597						
28.2	715	18.0	680	16.5	621	15.3	570	14.3	528	12.6	461				
191.2	1200	183.8	1150												
128.8	1100	123.4	1050	112.5	955	101.3	856								
106.3	1367	101.4	1300												
73.5	1267	69.8	1200	63.1	1081	57.6	985								
69.9	1633	66.6	1550												
50.8	1567	48.9	1500	44.2	1349										
34.2	1367	32.7	1300	29.9	1182	27.4	1081								



Short Description

ATLANTA HP high-performance worm gear units have been specially developed for use with the latest three-phase and DC servo-motors. Like all other components in this catalog, they are usually available ex stock or, at least, within a very short time.

The following are typical features of our HP High-Performance Gear Units:

- low-clearance gearing (backlash $< 2'$), adjustable
- up to 70 % higher loading values
- casing of light metal for optimal heat dissipation
- robust bevel roller bearings for the output drive hollow shaft, permitting greater additional forces.

Center distances, gear ratios and tooth systems have been chosen in accordance with DIN 3975/76. The tooth shape was optimised so as to permit the adjustment of the clearance simply by changing the center distance by means of eccentric flanges.

The use of ground, right-hand worms, a worm gear of special worm-gear bronze and dip-feed lubrication (synthetic special oil) ensures a high degree of efficiency and also smooth running in both directions and a long service life. The fully machined casing with its many fixing bores and tapped holes permits mounting in any position.

The demand for an absolutely positive, and largely torsion-free connection between gear unit and output shaft, as it is especially important for intermittent operation, is fulfilled by our new gear units using shrink-disk coupling with the output drive shaft.

The drive, i.e. the connection with the driving motor, is achieved with a special clutch. Its internal gearing, together with the barrelled profile of the driving shaft of our worm gear unit ensures transmission of the power with no free play. The use of annular spring elements firmly fixed to the motor shaft serves the same purpose.

For the output drive you can choose from quite a number of output drive shafts with straight and helical tooth systems and various numbers of teeth. Apart from pinion shafts there is a multitude of gearwheels with different numbers of teeth from our gearwheel program which can be combined and used together with suitable special output drive shafts. The whole range of drive shafts, like our gear units, is of course available for key and shrink-fit connection.

Racks ideally supplement our programme of standard elements for servo drive units. Our off-the shelf programme ranges from relatively simple, soft racks through hardened racks available with straight tooth system or with helical tooth system for smooth running, to the fully ground, low-tolerance types.

For emergency stops, the maximum transmittable torque of the gear unit (see page GB-13) and shrink disk (see page GH-1) has to be checked. The output keyway has to be calculated separately.





Mounting Instructions

Worm Gear Units

Five mounting faces with sufficiently dimensioned tapped holes are provided for mounting in any position. In order to accommodate all supplementary forces (see page GB-14) we recommend mounting at the largest contact faces., i.e. at one of the two cap sides. Putting the worm shaft (input shaft) in a lateral or inferior position is ideal for lubrication. Mounting the shaft in a top position will reduce the driving capacity by about 10%.



Coupling

The coupling will be delivered pre-assembled. Before attaching it to the motor shaft all contact surfaces must be cleaned and protected by applying a thin oil film. A retaining ring inserted in the hub of the coupling locks it on the motor shaft preventing axial movement of the coupling. It may be necessary to insert this ring in the next recess.

Recommended sequence:

- Slide the coupling onto the motor shaft until it clicks home (shoulder/retaining ring).
- Tighten the clamping screws slightly and check the coupling for true running.
- Tighten screws alternately crosswise using torque figures as shown in the operation and maintenance instructions ensuring that the gap between coupling and contact face remains even.
- A final check of true running is recommended at the applicable reference diameter!

A mounting guide can be found on page GI-1 to GI-4

Motor

Insert the motor with coupling mounted into the gear centering piece and bolt it to the gearbox.

Output Pinion Shaft

Unless the output pinion shaft comes already fully assembled, we recommend to proceed as follows:

Clean pinion shaft and hollow shaft extension and then oil them. For the special output drive shaft we recommend tolerance h6 (DIN ISO286). the material must have a minimum yield point of 385 N/mm². A recalculation of the strength is necessary.

Output Drive Shaft for Shrink-Disk Connection

Slide shrink disk onto the hollow shaft extension of the gear unit (please do not tighten the screws beforehand!). Insert the output shaft from the desired side into the hollow shaft fully up to the stop. Make the transverse pressure connection by evenly tightening the clamping screws. Tighten the screws one after the other (not crosswise) in several passes to the torque indicated in the operation and maintenance instructions.



Output Drive Shaft for Key Connection - The retaining ring, the disk and the screw supplied with the output drive shaft serve for locking the output shaft in axial direction. For this purpose insert the retaining ring in the applicable recess of the hollow shaft and slide the output drive shaft from the desired side into the hollow shaft up to the stop. Disk and screw are screwed to the output shaft from the other side of the gear unit. The retaining ring must be clamped between disk and pinion shaft.



Maintenance

Adjustment of Circumferential Backlash

The units are set up in the factory with a minimal amount of backlash. After prolonged usage, backlash may increase due to wear (reference value >15'). It can be adjusted by moving the eccentrically supported output shaft (= worm wheel).

We recommend to proceed as follows:

Unscrew the hexagon socket head screw of the two end caps without removing the caps in order to avoid oil leakage. Turn both caps towards the next higher number marked on the casing ensuring that they are both moved by the same amount. Check the backlash by turning the worm gear at least one complete revolution. If necessary, adjust further by another step. Evenly retighten the hexagon socket head screws alternately crosswise. An alteration of the gear center distance in relation to the overall operating conditions of the unit must be made up for by adjusting the attachment of the gear unit.

Lubricant Change

In the factory the gear units are filled with a synthetic lubricant and test run. They are delivered ready for use. A check of the lubricant level once a month - during the first weeks of operation more frequently - is recommended. Under normal load conditions and with single shift working it is recommended that the lubricant be changed every four years, with 2 or 3 shift working the lubricant should be changed annually. To do this, the unit must be emptied, flushed through and then refilled to the oil-level hole approximately in the middle of the gear unit using one of the lubricants recommended below. (Important: Synthetic lubricants must not be mixed with mineral oils.) For oil quantities see table.

Center Distance	Oil Quantity
a = 50 mm	0.3 l
a = 63 mm	0.5 l
a = 80 mm	1.2 l
a = 100 mm	2.0 l
a = 125 mm	4.0 l

We recommend the following synthetic gear lubricant:

Klübersynth GH 6 - 220
Order code: 65 90 010 (1 liter)

Alternative:

SHELL Tivela S 220, BP Enersyn SG-XP 220, ARAL Degol GS 220

Degree to Protection

Degree of protection: IP65/67 according to DIN ISO 20653
 (Corrosion has to be verified separately).



	Page
E Economy Gear Units with <5' Backlash	GC2 – GC11
Center Distance 32 mm	GC2 – GC3
Center Distance 50 mm	GC4 – GC5
Center Distance 63 mm	GC6 – GC7
Center Distance 80 mm	GC8 – GC9
Center Distance 100 mm	GC10 – GC11
Couplings and Shrink-Disk	GC12 – GC13
Selection and Load Tables	GC14 – GC16
Short Description	GC17
Mounting and Maintenance	GC18 – GC19
Gear Units Calculation and Selection	GF1 – GF3
Gear Units Accessories	GG1 – GG8
Motor Applications	GI5 – GI9





Center Distance

$a_o = 32 \text{ mm}$

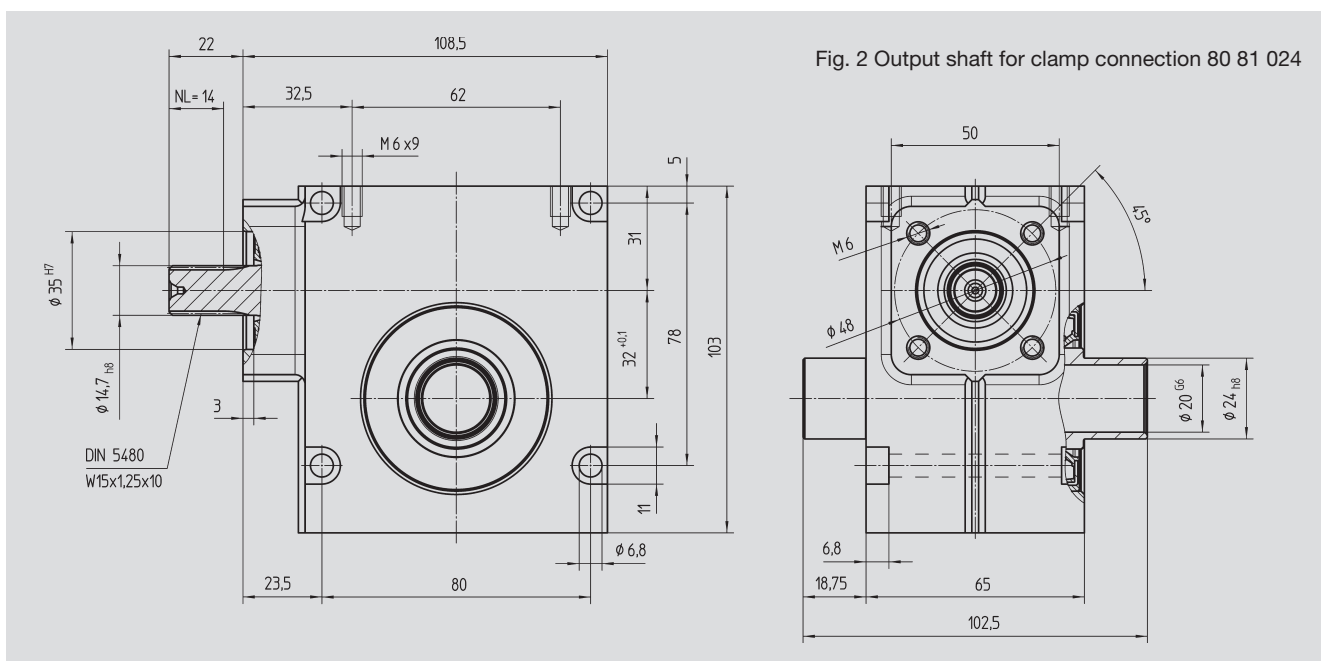
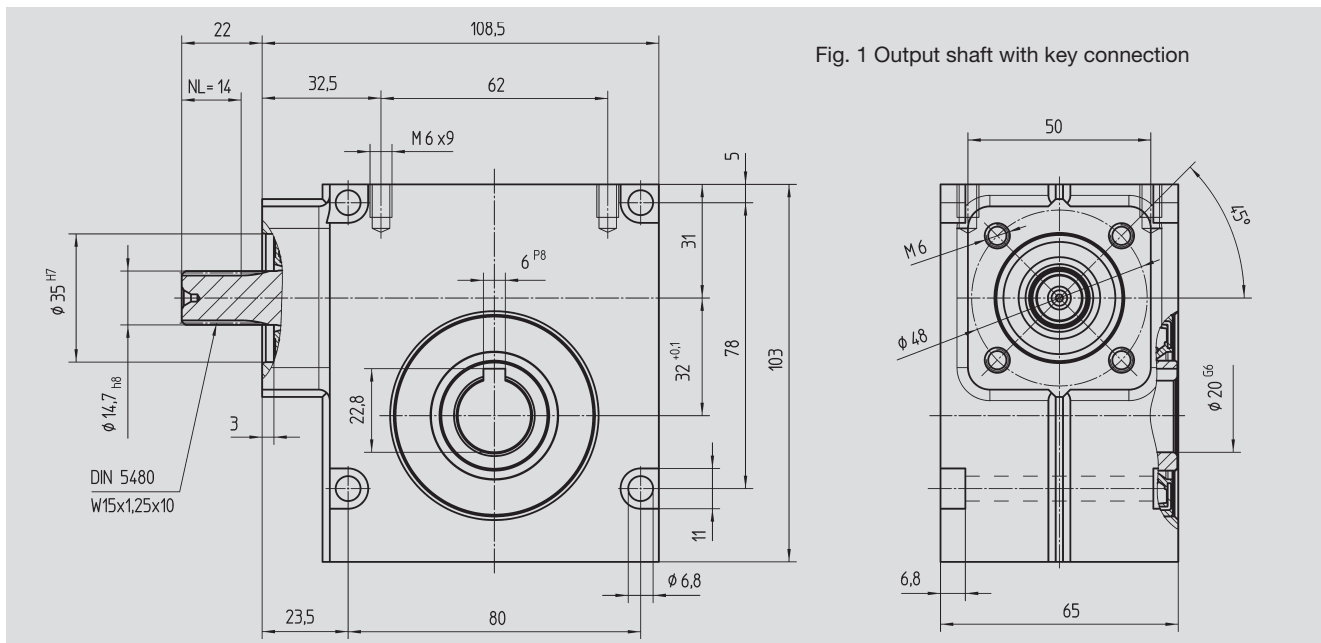

Order Code Fig. 1	Fig. 2	Ratio i	kg	$J_{red} 10^{-4}$ kg m ²
59 01 005	59 11 005	4.75	2	0.8280
59 01 007	59 11 007	6.75	2	0.4140
59 01 009	59 11 009	9.25	2	0.3490
59 01 015	59 11 015	14.50	2	0.2800
59 01 020	59 11 020	19.50	2	0.1960
59 01 029	59 11 029	29.00	2	0.2694
59 01 039	59 11 039	39.00	2	0.2310
59 01 050	59 11 050	50.00	2	0.2140

With food grade oil, order code 59 01 1xx / 59 11 1xx

With ATEX version with food grade oil, order code 59 01 2xx / 59 11 2xx



Motor Flange

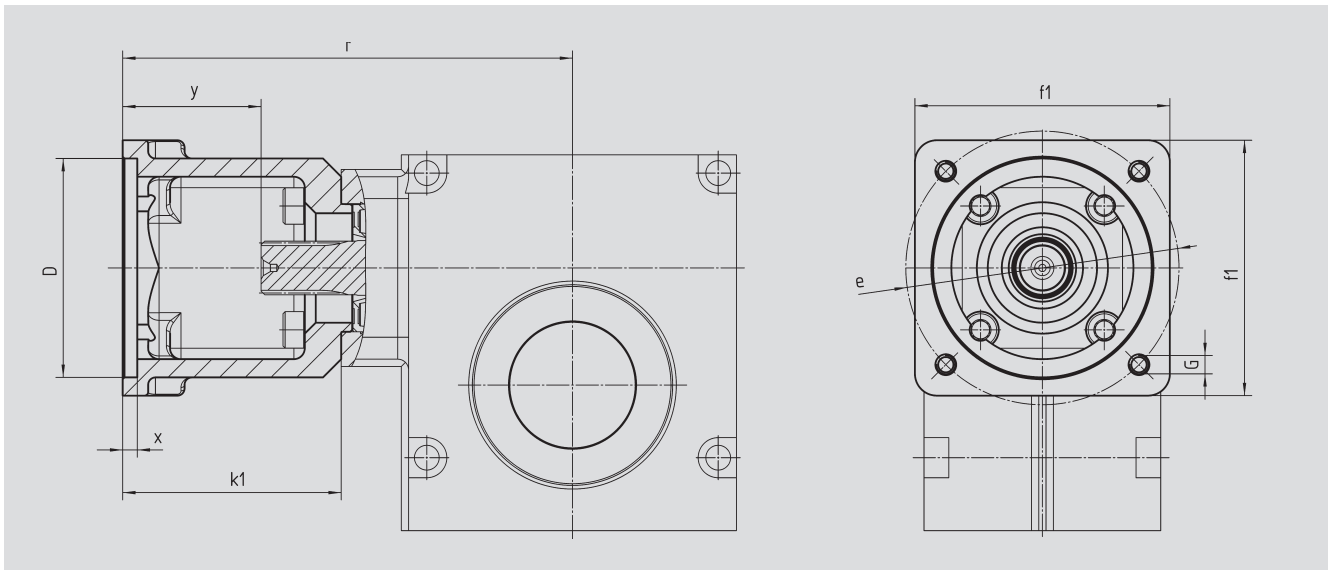

Center Distance

$a_o = 32 \text{ mm}$

Order Code	D^{G7}	k_1	r	x	y	f_1	e	G	 kg
65 59 101	40.0	56.5	120.0	2.5	34.5	60	63	M5	0.26
65 59 102	50.0	64.0	127.5	4.0	42.0	60	70	M5	0.29
65 59 103	60.0	60.0	123.5	3.5	38.0	70	75	M5	0.28
65 59 104	80.0	64.0	127.5	4.5	42.0	85	100	M6	0.30
65 59 105	60.0	64.0	127.5	4.5	42.0	85	90	M5	0.30
65 59 107	40.0	56.5	120.0	2.5	34.5	60	63	M4	0.31
65 59 108	70.0	64.0	127.5	5.0	42.0	85	90	M6	0.26

The order should contain gear box 59 01 0xx / 59 11 0xx and flange 65 59 1xx.



Center Distance

$a_o = 50 \text{ mm}$

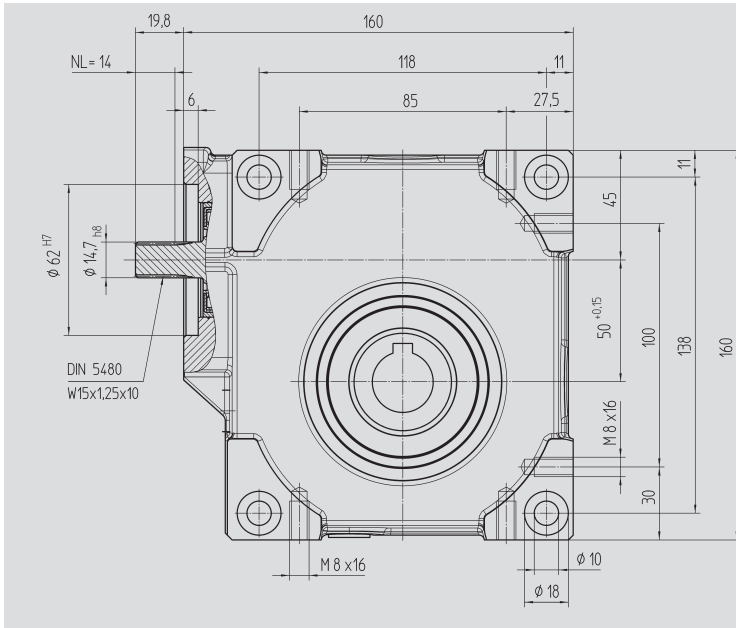

Fig. 1 Output shaft with key connection

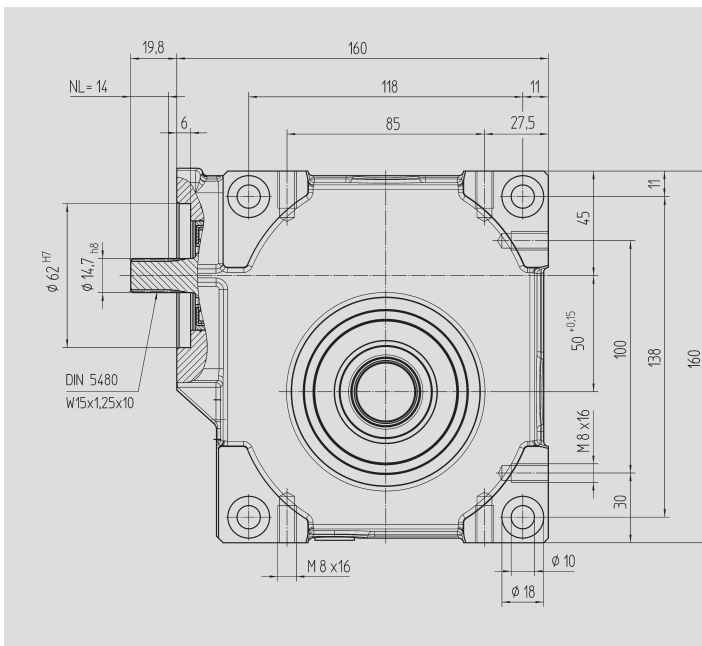
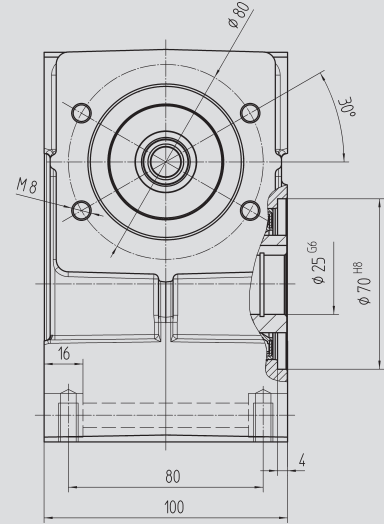
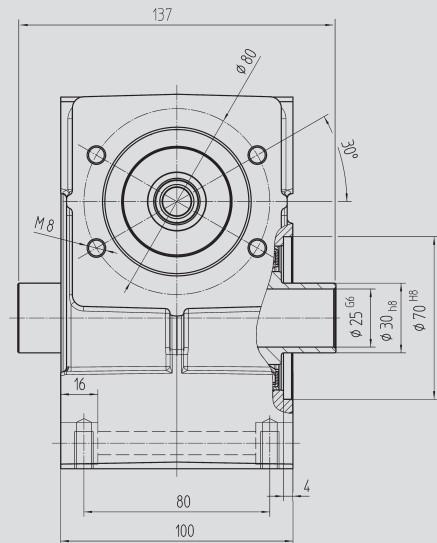

Fig. 2 Output shaft for clamp connection 80 83 030



Order Code
Fig. 1

Fig. 2

Ratio i



J_{red} 10⁻⁴
kg m²

59 03 005	59 13 005	4.75	6.5	0.8280
59 03 007	59 13 007	6.75	6.5	0.4140
59 03 009	59 13 009	9.25	6.5	0.3490
59 03 015	59 13 015	14.50	6.5	0.2800
59 03 020	59 13 020	19.50	6.5	0.1960
59 03 029	59 13 029	29.00	6.5	0.2694
59 03 039	59 13 039	39.00	6.5	0.2310
59 03 050	59 13 050	50.00	6.5	0.2140

With food grade oil, order code 59 03 1xx / 59 13 1xx

With ATEX version with food grade oil, order code 59 03 2xx / 59 13 2xx



Motor Flange

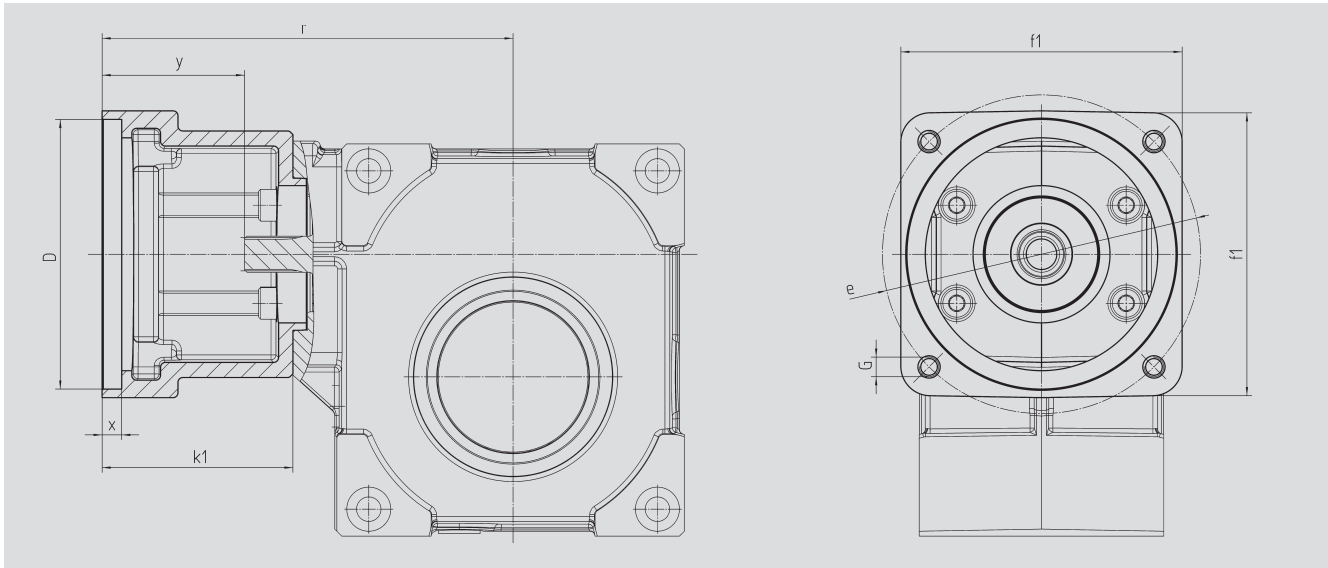

Center Distance

$a_o = 50 \text{ mm}$

Order Code	D ^{G7}	k ₁	r	x	y	f ₁	e	G	 kg
65 59 301	95.0	62	152	12.5	42	100	115	M8	0.60
65 59 302	50.0	62	152	10.0	42	100	70, 95, 115	M4, M6, M8	0.70
65 59 303	80.0	62	152	10.0	42	100	100	M6	0.65
65 59 304	95.0	78	168	10.0	59	115	130	M8	0.80
65 59 305	95.0	72	162	8.0	52	100	115	M8	0.75
65 59 306	60.0	74	164	21.0	54	100	75, 90, 115	M5, M5, M8	0.90
65 59 307	70.0	70	160	21.0	50	100	90, 115	M6, M8	0.80
65 59 401	95.0	73	163	8.0	53	100	115	M8	0.75
65 59 402	110.0	78	168	8.0	59	115	130	M8	0.80
65 59 403	95.0	73	163	12.0	53	115	130	M8	0.75
65 59 404	110.0	73	163	12.0	53	115	130	M8	0.70
65 59 405	95.0	78	168	11.0	59	140	165	M10	1.20
65 59 406	110.0	78	168	11.0	59	140	165	M10	1.15
65 59 407	130.0	78	168	11.0	59	140	165	M10	1.00
65 59 409	130.0	98	188	14.0	78	140	165	M10	1.10
65 59 410	110.0	74	164	8.0	54	120	145	M8	1.00
65 59 411	110.0	84	174	8.0	64	120	145	M8	1.20
65 59 412	114.3	105	195	8.0	85	180	200	M12	3.70
65 59 413	114.3	139	229	8.0	119	180	200	M12	3.35
65 59 414	114.3	91	181	8.0	71	180	200	M12	2.65
65 59 415	110.0	89	179	8.0	69	120	145	M8	1.30

The order should contain gear box 59 03 0xx / 59 13 0xx and flange 65 59 3xx or 4xx.



Center Distance

$a_o = 63 \text{ mm}$

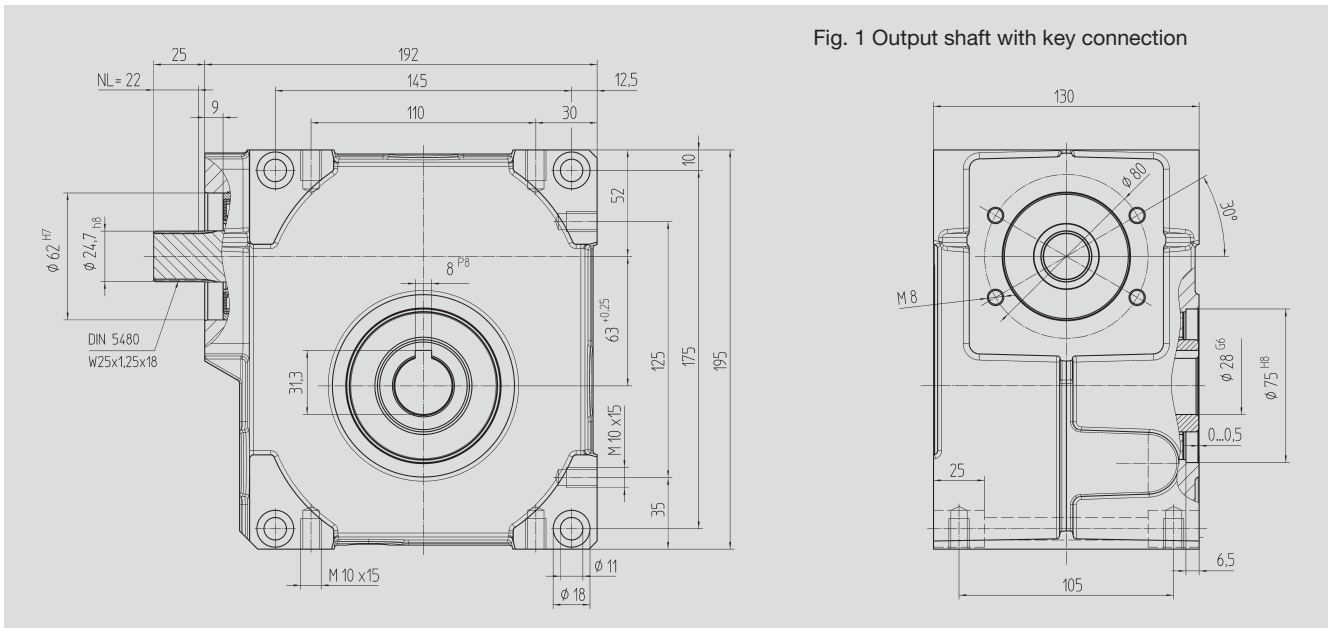

Fig. 1 Output shaft with key connection

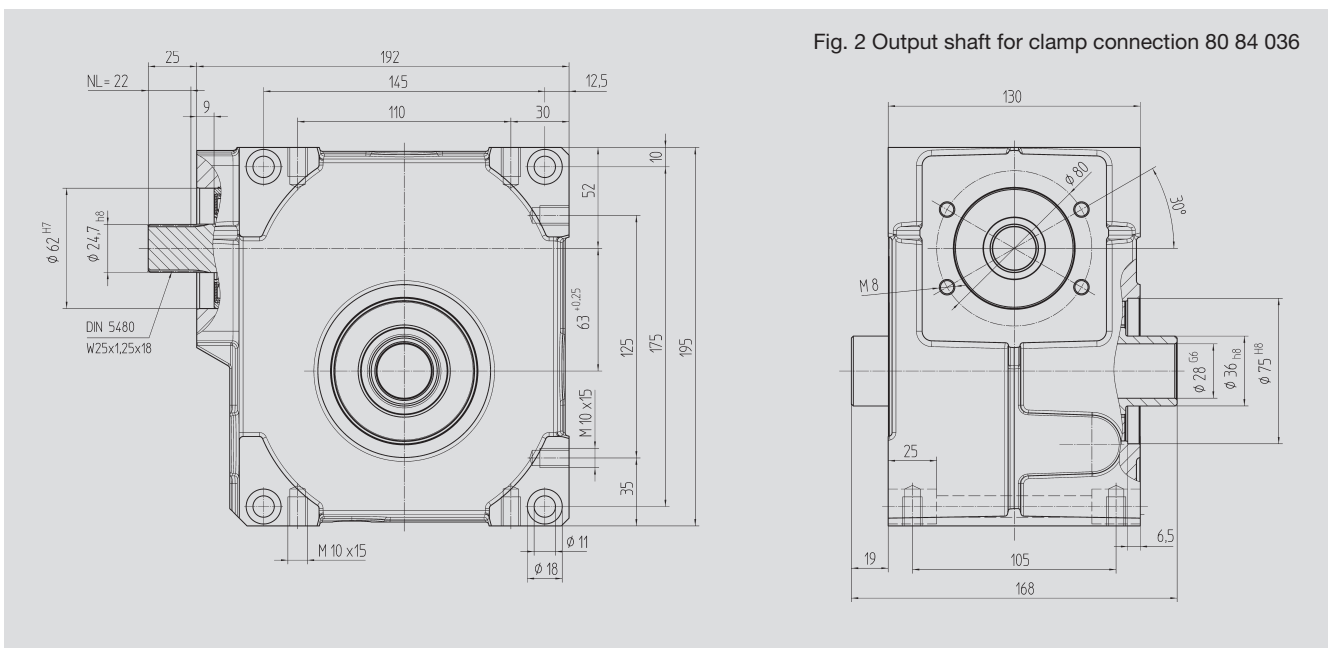

Fig. 2 Output shaft for clamp connection 80 84 036

Order Code Fig. 1	Fig. 2	Ratio i	kg	$J_{red} 10^{-4}$ kg m ²
59 04 005	59 14 005	4.75	11.5	2.5350
59 04 007	59 14 007	6.75	11.5	1.3720
59 04 009	59 14 009	9.25	11.5	0.9825
59 04 015	59 14 015	14.50	11.5	0.9590
59 04 020	59 14 020	19.50	11.5	0.6940
59 04 029	59 14 029	29.00	11.5	0.9966
59 04 039	59 14 039	39.00	11.5	1.0100
59 04 052	59 14 052	52.00	11.5	0.5305

With food grade oil, order code 59 04 1xx / 59 14 1xx

With ATEX version with food grade oil, order code 59 04 2xx / 59 14 2xx



Motor Flange

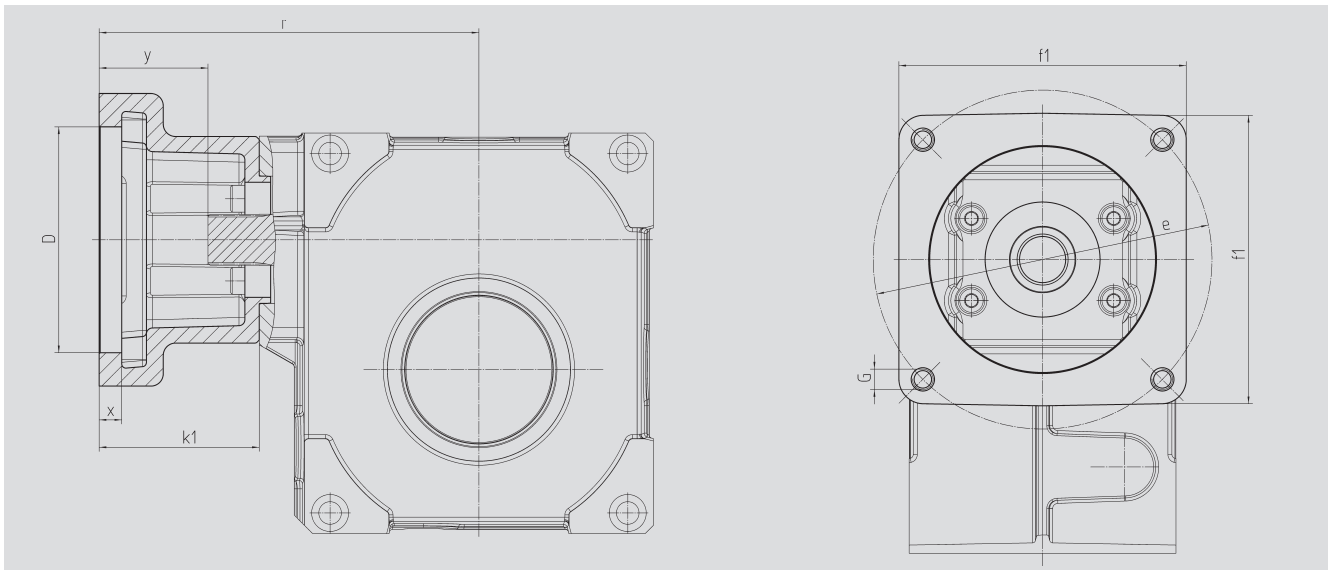

Center Distance

$a_o = 63 \text{ mm}$

Order Code	D ^{G7}	k ₁	r	x	y	f ₁	e	G	kg
65 59 301	95.0	62	169	12.5	37	100	115	M8	0.60
65 59 302	50.0	62	169	10.0	37	100	70, 95, 115	M4, M6, M8	0.70
65 59 303	80.0	62	169	10.0	37	100	100	M6	0.65
65 59 304	95.0	78	185	10.0	53	115	130	M8	0.80
65 59 305	95.0	72	179	8.0	47	100	115	M8	0.75
65 59 306	60.0	74	181	21.0	49	100	75, 90, 115	M5, M5, M8	0.90
65 59 307	70.0	70	177	21.0	45	100	90, 115	M6, M8	0.80
65 59 401	95.0	73	180	8.0	48	100	115	M8	0.75
65 59 402	110.0	78	185	8.0	53	115	130	M8	0.80
65 59 403	95.0	73	180	12.0	48	115	130	M8	0.75
65 59 404	110.0	73	180	12.0	48	115	130	M8	0.70
65 59 405	95.0	78	185	11.0	53	140	165	M10	1.20
65 59 406	110.0	78	185	11.0	53	140	165	M10	1.15
65 59 407	130.0	78	185	11.0	53	140	165	M10	1.00
65 59 409	130.0	98	205	14.0	73	140	165	M10	1.10
65 59 410	110.0	74	181	8.0	49	120	145	M8	1.00
65 59 411	110.0	84	191	8.0	59	120	145	M8	1.20
65 59 412	114.3	105	212	8.0	80	180	200	M12	3.70
65 59 413	114.3	139	246	8.0	114	180	200	M12	3.35
65 59 414	114.3	91	198	8.0	66	180	200	M12	2.65
65 59 415	110.0	89	196	8.0	64	120	145	M8	1.30

The order should contain gear box 59 04 0xx / 59 14 0xx and flange 65 59 3xx or 4xx.



Center Distance

$a_o = 80 \text{ mm}$

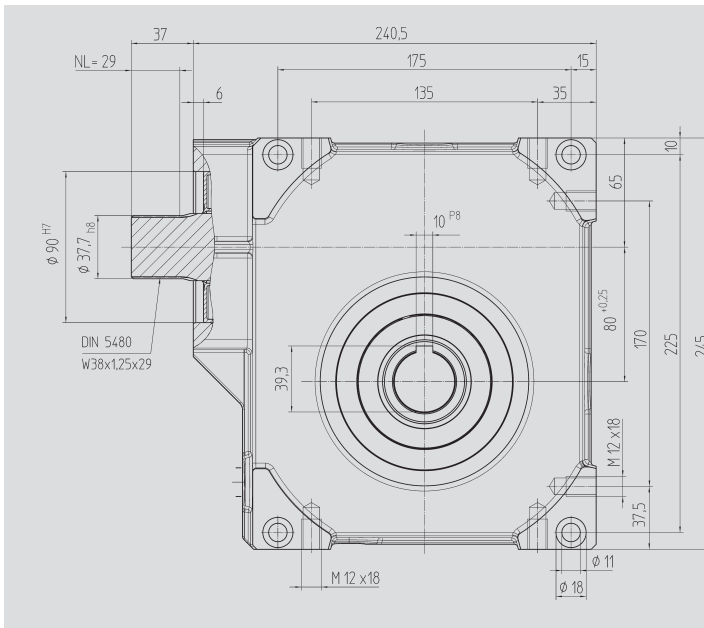

Fig. 1 Output shaft with key connection

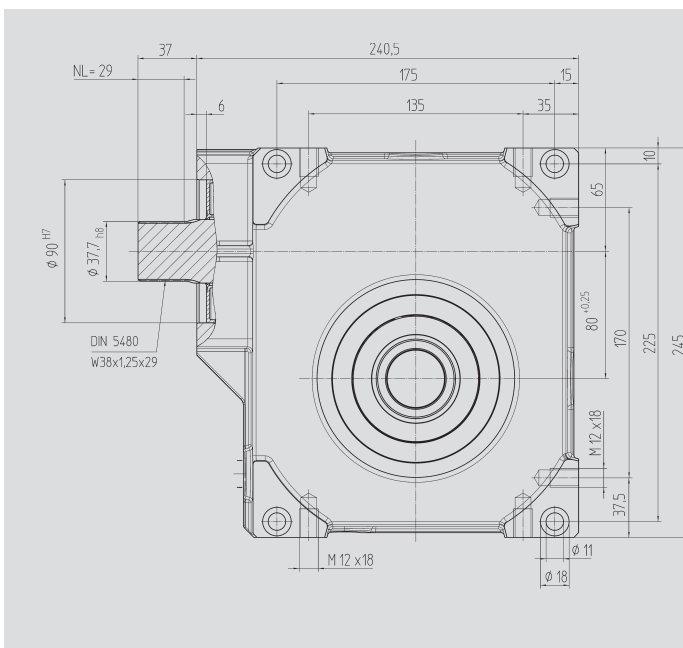
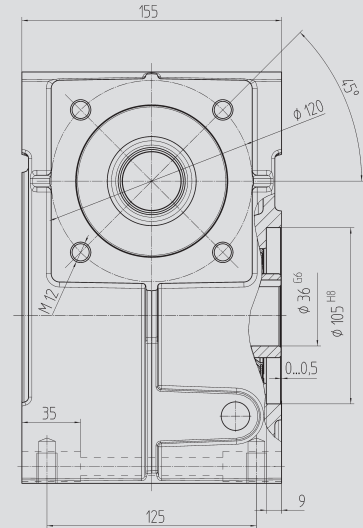
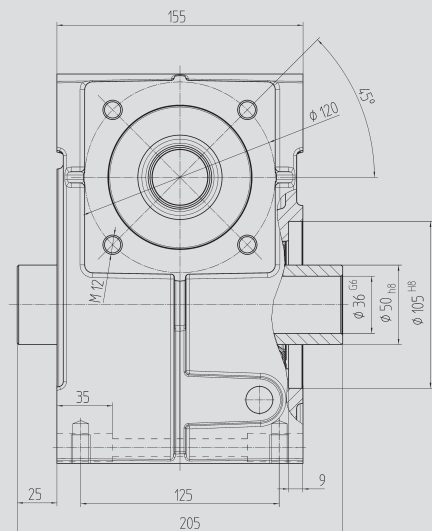

Fig. 2 Output shaft for clamp connection 80 85 050



Order Code Fig. 1	Fig. 2	Ratio i	kg	$J_{red} 10^{-4}$ kg m ²
59 05 005	59 15 005	4.75	22	9.6180
59 05 007	59 15 007	6.75	22	6.0910
59 05 009	59 15 009	9.25	22	4.7650
59 05 015	59 15 015	14.50	22	5.3080
59 05 020	59 15 020	19.50	22	3.9350
59 05 029	59 15 029	29.00	22	4.0500
59 05 039	59 15 039	39.00	22	4.1800
59 05 052	59 15 052	52.00	22	3.7140

With food grade oil, order code 59 05 1xx / 59 15 1xx

With ATEX version with food grade oil, order code 59 05 2xx / 59 15 2xx



Motor Flange

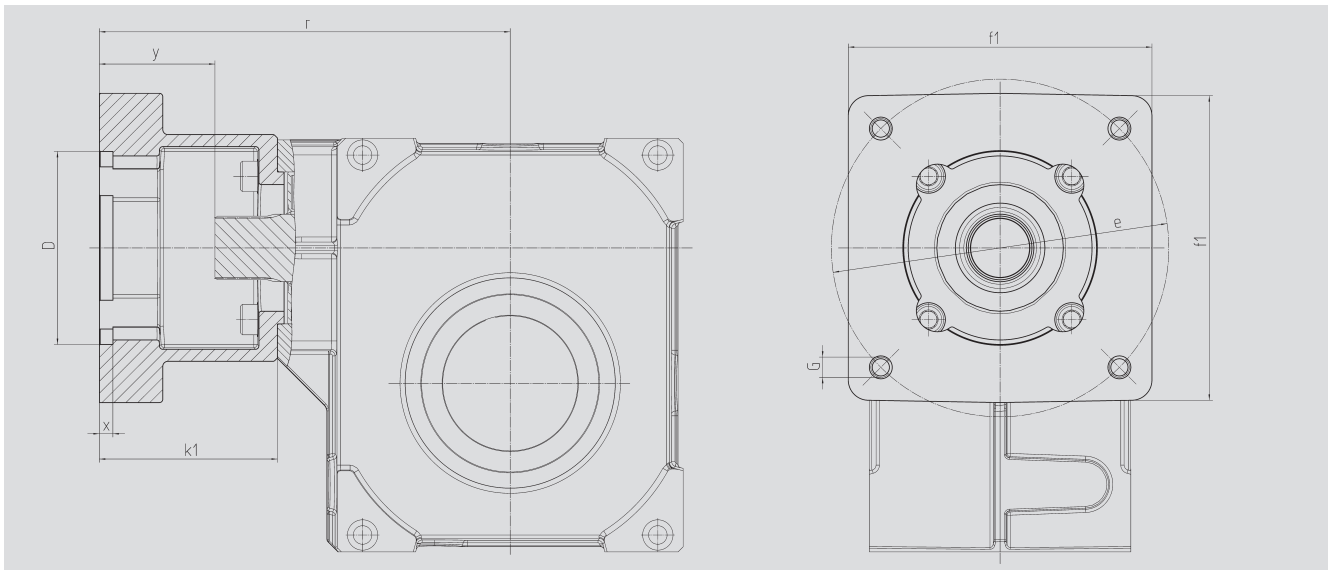

Center Distance

$a_o = 80 \text{ mm}$

Order Code	D ^{G7}	k ₁	r	x	y	f ₁	e	G	 kg
65 59 501	110.0	92.0	230.0	8.0	55.0	140	165	M10	2.00
65 59 502	130.0	92.0	230.0	8.0	55.0	140	165	M10	1.90
65 59 503	180.0	122.0	260.0	8.0	85.0	192	215	M12	3.40
65 59 504	180.0	127.0	265.0	8.0	90.0	192	215	M12	3.80
65 59 505	180.0	112.0	250.0	10.0	75.0	192	215	M12	2.70
65 59 506	130.0	112.0	250.0	10.0	75.0	192	215	M12	3.00
65 59 507	130.0	112.0	250.0	10.0	75.0	140	165	M10	2.50
65 59 508	110.0	90.0	228.0	8.0	53.0	140	145	M8	2.00
65 59 509	110.0	108.5	246.5	8.0	71.5	140	145	M8	2.50
65 59 510	114.3	129.5	267.5	8.0	92.5	180	200	M12	5.00
65 59 511	114.3	163.5	301.5	8.0	126.5	180	200	M12	4.20
65 59 512	114.3	105.5	243.5	8.0	68.5	180	200	M12	3.50
65 59 513	110.0	113.5	251.5	8.0	76.5	140	145	M8	2.70

The order should contain gear box 59 05 0xx / 59 15 0xx and flange 65 59 5xx.



Center Distance

$a_o = 100 \text{ mm}$

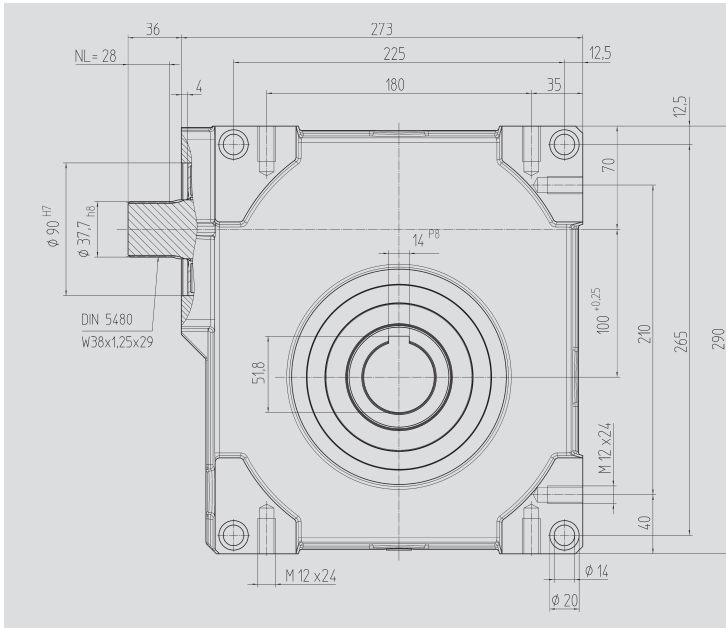

Fig. 1 Output shaft with key connection

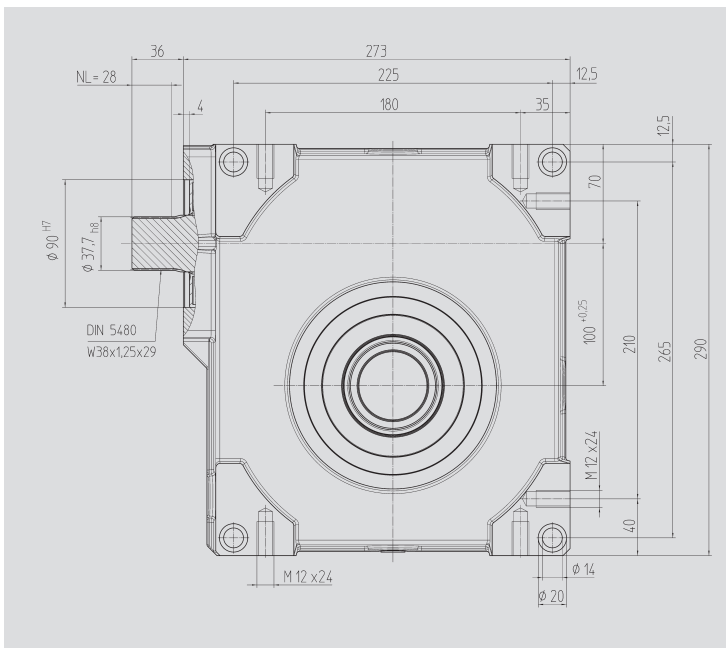
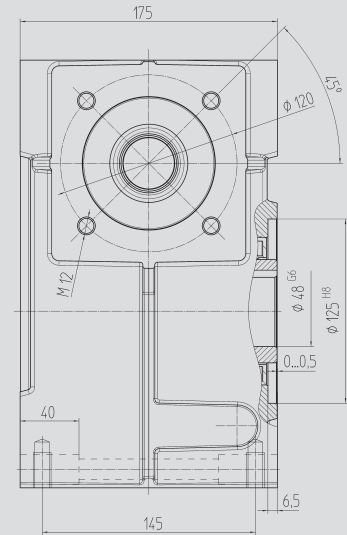
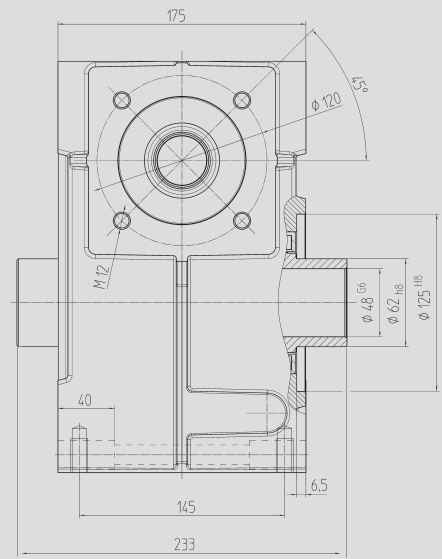

Fig. 2 Output shaft for clamp connection 80 86 062



Order Code Fig. 1	Fig. 2	Ratio i	kg	$J_{red} 10^{-4}$ kg m ²
59 06 005	59 16 005	4.75	37	22.9320
59 06 007	59 16 007	6.75	37	12.8835
59 06 009	59 16 009	9.25	37	8.0975
59 06 015	59 16 015	14.50	37	7.2190
59 06 020	59 16 020	19.50	37	5.4030
59 06 029	59 16 029	29.00	37	4.7207
59 06 039	59 16 039	39.00	37	8.4300
59 06 052	59 16 052	52.00	37	9.7400

With food grade oil, order code 59 06 1xx / 59 16 1xx

With ATEX version with food grade oil, order code 59 06 2xx / 59 16 2xx



Motor Flange

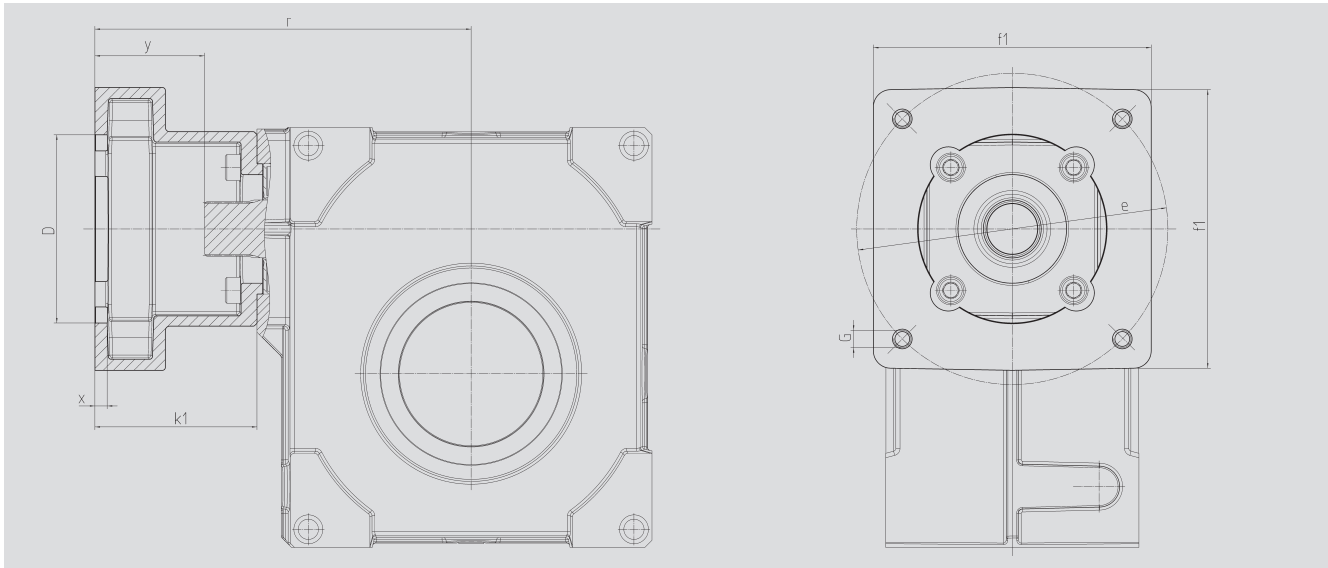

Center Distance

$a_o = 100 \text{ mm}$

Order Code	D ^{G7}	k ₁	r	x	y	f ₁	e	G	kg
65 59 501	110.0	92.0	240.0	8.0	55.0	140	165	M10	2.00
65 59 502	130.0	92.0	240.0	8.0	55.0	140	165	M10	1.90
65 59 503	180.0	122.0	270.0	8.0	85.0	192	215	M12	3.40
65 59 504	180.0	127.0	275.0	8.0	90.0	192	215	M12	3.80
65 59 505	180.0	112.0	260.0	10.0	75.0	192	215	M12	2.70
65 59 506	130.0	112.0	260.0	10.0	75.0	192	215	M12	3.00
65 59 507	130.0	112.0	260.0	10.0	75.0	140	165	M10	2.50
65 59 508	110.0	90.0	238.0	8.0	53.0	140	145	M8	2.00
65 59 509	110.0	108.5	256.5	8.0	71.5	140	145	M8	2.50
65 59 510	114.3	129.5	277.5	8.0	92.5	180	200	M12	5.00
65 59 511	114.3	163.5	311.5	8.0	126.5	180	200	M12	4.20
65 59 512	114.3	105.5	253.5	8.0	68.5	180	200	M12	3.50
65 59 513	110.0	113.5	261.5	8.0	76.5	140	145	M8	2.70

The order should contain gear box 59 06 0xx / 59 16 0xx and flange 65 59 5xx.



Special Couplings for Motor/Gear Units, rigid model, nitrided, preassembled for motor shafts without key

Bore on gear unit side
low-clearance tooth-hub
profile corresponding to
DIN 5480 for push-fitting

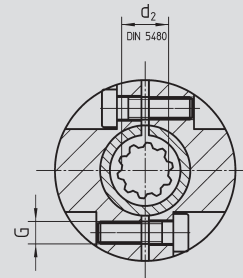
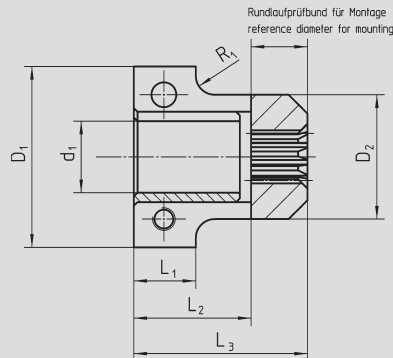

Order Code

Coupling	d ₁	d ₂	D ₁	D ₂	L ₁	L ₃	R ₁	G	L ₂	J _{red} 10 ⁻⁴ kg m ²	kg
65 51 008	8	15x1.25x10	36	23	14.0	46.0	5	M5	31.2	0.236	0.2
65 51 009	9	15x1.25x10	36	23	14.0	46.0	5	M5	31.2	0.246	0.2
65 51 010	10	15x1.25x10	36	23	14.0	46.0	5	M5	31.2	0.244	0.2
65 51 011	11	15x1.25x10	36	23	14.0	46.0	5	M5	31.2	0.243	0.2
65 51 014	14	15x1.25x10	36	23	14.0	46.0	5	M5	31.2	0.234	0.2
65 51 016	16	15x1.25x10	36	23	14.0	46.0	5	M5	31.2	0.225	0.2
65 53 019	19	15x1.25x10	48	33	16.5	46.0	5	M6	31.2	0.704	0.3
65 53 020	20	15x1.25x10	48	33	16.5	46.0	5	M6	31.2	0.704	0.3
65 53 022	22	15x1.25x10	48	33	16.5	46.0	5	M6	31.2	0.704	0.3
65 53 024	24	15x1.25x10	48	33	16.5	46.0	5	M6	31.2	0.647	0.2
65 53 025	25	15x1.25x10	64	51	18.0	55.5	5	M8	41.5	5.946	1.1
65 53 028	28	15x1.25x10	64	51	18.0	55.5	5	M8	41.5	5.871	1.1
65 53 032	32	15x1.25x10	64	51	18.0	55.5	5	M8	41.5	4.158	0.8
65 53 035	35	15x1.25x10	78	51	18.0	55.5	5	M8	41.5	5.605	1.0
65 53 038	38	15x1.25x10	78	51	18.0	55.5	5	M8	41.5	5.432	0.9
65 54 009	9	25x1.25x18	49	35	17.0	68.0	5	M6	43.5	2.306	0.5
65 54 010	10	25x1.25x18	49	35	17.0	68.0	5	M6	43.5	2.300	0.5
65 54 011	11	25x1.25x18	49	35	17.0	68.0	5	M6	43.5	2.381	0.5
65 54 014	14	25x1.25x18	49	35	17.0	68.0	5	M6	43.5	1.161	0.5
65 54 015	15	25x1.25x18	49	35	17.0	68.0	5	M6	43.5	2.328	0.5
65 54 016	16	25x1.25x18	49	35	17.0	68.0	5	M6	43.5	1.161	0.5
65 54 019	19	25x1.25x18	49	35	17.0	68.0	5	M6	43.5	1.112	0.4
65 54 020	20	25x1.25x18	49	35	17.0	68.0	5	M6	43.5	2.268	0.5
65 54 022	22	25x1.25x18	49	35	17.0	68.0	5	M6	43.5	2.179	0.4
65 54 024	24	25x1.25x18	49	35	17.0	68.0	5	M6	43.5	1.007	0.4
65 54 025	25	25x1.25x18	64	51	18.0	68.0	5	M8	43.5	8.165	1.2
65 54 028	28	25x1.25x18	64	51	18.0	68.0	5	M8	43.5	8.061	1.2
65 54 032	32	25x1.25x18	64	51	18.0	68.0	5	M8	43.5	7.751	1.2
65 54 035	35	25x1.25x18	78	51	18.0	68.0	5	M8	43.5	7.690	1.1
65 54 038	38	25x1.25x18	78	51	18.0	68.0	5	M8	43.5	7.348	1.1
65 54 042	42	25x1.25x18	78	51	18.0	65.5	5	M8	43.5	6.595	1.1
65 55 014	14	38x1.25x29	64	51	18.0	72.5	5	M8	41.5	8.056	1.2
65 55 016	16	38x1.25x29	64	51	18.0	72.5	5	M8	41.5	8.029	1.2
65 55 019	19	38x1.25x29	64	51	18.0	72.5	5	M8	41.5	7.978	1.2
65 55 020	20	38x1.25x29	64	51	18.0	72.5	5	M8	41.5	7.945	1.2
65 55 022	22	38x1.25x29	64	51	18.0	72.5	5	M8	41.5	7.911	1.2
65 55 024	24	38x1.25x29	64	51	18.0	72.5	5	M8	41.5	7.860	1.2
65 55 025	25	38x1.25x29	64	51	18.0	72.5	5	M8	41.5	7.818	1.1
65 55 028	28	38x1.25x29	64	51	18.0	72.5	5	M8	41.5	8.105	1.3
65 55 032	32	38x1.25x29	64	51	18.0	72.5	5	M8	41.5	7.863	1.2
65 55 035	35	38x1.25x29	78	51	18.0	72.5	5	M8	41.5	7.610	1.1
65 55 038	38	38x1.25x29	78	51	18.0	72.5	5	M8	41.5	7.284	1.0
65 55 042	42	38x1.25x29	78	51	18.0	70.5	5	M8	41.5	6.547	1.0

Couplings on page GA-10 can be used as well.



Shrink-Disk Clamping Sets for Output Drive Shafts of gear series 59 1. ...

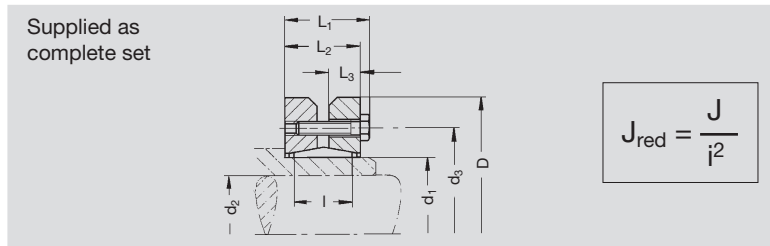

Order Code	a ₀ mm	T _{2max} Nm	d ₁	d ₂	d ₃	D	L ₁	L ₂	L ₃	l	G	J 10 ⁻⁴ kg m ²	kg
80 81 024	32	270	24	20	36	50	23.0	19.5	7.80	14.0	6 x M5	0.780	0.2
80 83 030	50	400	30	25	44	60	25.0	21.5	9.00	16.0	7 x M5	1.756	0.3
80 84 036	63	540	36	28	52	72	27.5	23.5	10.00	18.0	5 x M6	4.029	0.4
80 85 050	80	1180	50	36	70	90	31.5	27.5	12.00	22.5	9 x M6	11.322	0.8
80 86 062	100	2300	62	48	86	110	34.5	30.5	14.00	23.0	12 x M6	27.137	1.3



The values in the tables are based upon wear or maximum flank load at 12,000 hours full load and on servo-operation. With continuous full-load operation it may be necessary to consider temperature limits! (Please ask us if in doubt.)

T_{2max} = static torque to avoid tooth fracture. T_1 = input torque in Nm. T_2 = output torque in Nm.



Order Code	a_0 (mm)	i	T_{2max}	Input Speed n_1 (rpm)												
				250		500		750		1000		1500		2000		
				T_1 (Nm)	T_2 (Nm)	T_1 (Nm)	T_2 (Nm)	T_1 (Nm)	T_2 (Nm)	T_1 (Nm)	T_2 (Nm)	T_1 (Nm)	T_2 (Nm)	T_1 (Nm)	T_2 (Nm)	
59 01 003 59 11 003	32	3.00*														
59 01 005 59 11 005		4.75	135	3.2	12	4.2	16	4.1	16	4.4	17	3.8	17	4.3	17	
59 01 007 59 11 007		6.75	100	2.0	10	2.6	14	2.8	15	2.9	16	2.8	17	3.0	17	
59 01 009 59 11 009		9.25	65	1.3	9	1.8	12	1.8	13	2.0	14	1.8	15	2.1	16	
59 01 015 59 11 015		14.50	85	1.0	10	1.3	14	1.4	15	1.5	16	1.4	17	1.5	17	
59 01 020 59 11 020		19.50	55	0.7	9	0.9	12	0.9	12	1.0	13	0.9	14	1.1	15	
59 01 029 59 11 029		29.00	70	0.5	9	0.7	12	0.7	13	0.8	14	0.7	15	0.8	16	
59 01 039 59 11 039		39.00	50	0.5	10	0.6	13	0.7	14	0.7	15	0.6	16	0.7	17	
59 01 050 59 11 050		50.00	35	0.4	8	0.5	11	0.5	11	0.6	12	0.4	13	0.6	14	
59 03 003 59 13 003	50	3.00*														
59 03 005 59 13 005		4.75	550	11.6	48	15.1	65	15.1	65	16.3	70	16.4	70	16.5	70	
59 03 007 59 13 007		6.75	400	7.2	42	9.4	56	9.9	59	10.5	63	11.4	69	11.4	69	
59 03 009 59 13 009		9.25	275	4.8	35	6.3	48	6.5	51	6.9	54	7.4	58	7.9	62	
59 03 015 59 13 015		14.50	350	3.7	42	4.8	57	5.0	60	5.3	65	5.8	70	5.9	72	
59 03 020 59 13 020		19.50	250	2.4	33	3.1	45	3.3	48	3.4	50	3.7	55	3.9	58	
59 03 029 59 13 029		29.00	300	1.9	36	2.4	48	2.6	52	2.7	55	2.9	60	3.1	63	
59 03 039 59 13 039		39.00	200	1.8	39	2.3	52	2.4	56	2.5	60	2.7	65	2.8	68	
59 03 050 59 13 050		50.00	150	1.5	31	1.9	42	1.9	44	2.0	47	2.1	50	2.2	53	
59 04 003 59 14 003	63	3.00*														
59 04 005 59 14 005		4.75	1000	37.6	163	38.9	170	41.2	180	41.3	180	39.2	170	37.4	162	
59 04 007 59 14 007		6.75	750	21.5	129	27.9	170	29.4	180	29.4	180	27.9	170	26.6	162	
59 04 009 59 14 009		9.25	500	10.8	85	14.2	115	15.3	125	15.9	130	16.4	135	16.4	135	
59 04 015 59 14 015		14.50	600	11.1	132	13.6	165	14.7	180	14.7	180	14.7	180	14.5	177	
59 04 020 59 14 020		19.50	500	5.6	87	7.2	115	7.7	125	8.0	130	8.3	135	9.0	145	
59 04 029 59 14 029		29.00	650	6.9	137	8.4	175	9.1	190	9.7	205	10.5	220	10.1	212	
59 04 039 59 14 039		39.00	450	4.2	106	5.2	140	5.5	150	5.8	160	6.4	175	6.6	180	
59 04 052 59 14 052		52.00	300	2.4	71	3.0	95	3.3	105	3.5	115	3.8	125	4.0	133	
59 05 003 59 15 003	80	3.00*														
59 05 005 59 15 005		4.75	2000	102.9	453	94.9	420	85.9	380	81.5	360	75.0	330	71.5	313	
59 05 007 59 15 007		6.75	1400	65.2	402	67.6	420	61.1	380	57.8	360	53.2	330	50.7	313	
59 05 009 59 15 009		9.25	1100	37.5	310	44.2	370	44.1	370	42.9	360	39.3	330	37.5	313	
59 05 015 59 15 015		14.50	1300	34.9	431	35.9	450	35.8	450	33.4	420	29.4	370	27.5	345	
59 05 020 59 15 020		19.50	1000	21.9	353	22.5	370	24.2	400	24.1	400	21.7	360	20.9	347	
59 05 029 59 15 029		29.00	1200	22.9	498	23.3	520	24.5	550	23.6	530	21.8	490	20.8	467	
59 05 039 59 15 039		39.00	850	15.0	412	15.1	430	16.0	460	17.0	490	16.7	480	15.9	457	
59 05 052 59 15 052		52.00	600	6.3	216	6.6	240	7.1	260	7.5	275	8.2	300	8.5	310	
59 06 005 59 16 005	100	4.75	3300	234.2	1043	197.3	880	179.6	800	169.1	750	154.3	685	147.1	650	
59 06 007 59 16 007		6.75	2300	127.2	797	131.8	830	119.1	750	114.8	720	105.3	660	101.3	633	
59 06 009 59 16 009		9.25	1900	94.3	794	97.6	830	88.1	750	84.8	720	77.7	660	74.8	633	
59 06 015 59 16 015		14.50	2050	70.0	892	72.2	930	68.2	880	62.9	810	55.9	720	53.5	687	
59 06 020 59 16 020		19.50	1800	51.8	861	53.3	900	51.3	870	47.8	810	42.5	720	40.6	687	
59 06 029 59 16 029		29.00	2300	48.7	1103	49.9	1150	46.1	1070	43.7	1010	36.8	850	36.2	833	
59 06 039 59 16 039		39.00	1650	35.2	1034	35.8	1080	34.0	1030	33.0	1000	29.7	900	28.5	860	
59 06 052 59 16 052		52.00	1100	20.7	759	20.0	760	21.5	820	22.3	850	20.6	785	19.7	750	

* On request



Input Speed n_1 (rpm)															
2500		3000		3500		4000		4500		5000		5500		6000	
T_1 (Nm)	T_2 (Nm)	T_1 (Nm)	T_2 (Nm)	T_1 (Nm)	T_2 (Nm)	T_1 (Nm)	T_2 (Nm)	T_1 (Nm)	T_2 (Nm)	T_1 (Nm)	T_2 (Nm)	T_1 (Nm)	T_2 (Nm)	T_1 (Nm)	T_2 (Nm)
4.3	17	4.3	17	4.4	18	4.5	18	4.5	18	4.5	18	4.3	17	4.1	16
3.0	17	3.0	17	3.1	18	3.1	18	3.1	18	3.1	18	3.3	19	3.4	19
2.2	16	2.3	17	2.3	18	2.4	18	2.3	18	2.4	18	2.5	19	2.6	19
1.6	18	1.6	18	1.6	18	1.6	18	1.5	18	1.6	18	1.6	19	1.7	19
1.1	15	1.1	16	1.1	16	1.1	16	1.1	16	1.1	16	1.1	17	1.2	17
0.9	16	0.9	17	0.9	17	0.9	17	0.9	17	0.9	17	0.9	18	1.0	18
0.8	17	0.8	18	0.8	18	0.8	18	0.8	18	0.8	18	0.8	19	0.8	19
0.6	14	0.6	15	0.6	16	0.7	16	0.7	17	0.7	18	0.8	19	0.8	19
25.0	70	16.8	70	16.3	67	15.8	65	15.5	63	15.1	61	14.3	57	13.6	53
17.2	69	11.6	69	11.3	67	11.0	65	10.7	63	10.5	61	9.9	57	9.4	54
12.6	66	8.9	70	8.9	70	8.9	70	8.7	67	8.4	65	8.0	61	7.6	58
9.1	73	6.2	75	6.2	75	6.3	75	6.3	75	6.4	75	6.1	70	5.8	67
6.1	61	4.3	65	4.3	65	4.3	65	4.3	65	4.4	65	4.2	61	4.0	58
4.9	67	3.5	70	3.5	70	3.5	70	3.4	67	3.3	65	3.2	61	3.0	57
4.4	71	3.1	75	3.1	75	3.1	75	3.1	75	3.1	75	3.0	70	2.9	66
3.4	57	2.4	60	2.4	60	2.4	60	2.4	60	2.4	60	2.5	62	2.5	64
53.4	153	34.0	145	32.9	140	31.9	135	29.6	124	27.5	115				
38.1	153	24.1	145	23.4	140	22.7	135	21.1	125	19.8	116	18.6	109		
24.6	135	16.5	135	16.0	130	15.6	126	14.6	117	13.8	110	13.0	104	12.4	98
21.4	173	14.1	170	13.7	165	13.4	160	12.5	148	11.7	138	11.1	130		
14.4	155	10.3	165	9.9	160	9.7	155	9.1	144	8.6	136	8.2	128	7.8	121
14.6	203	9.4	195	9.3	190	9.1	185	8.5	171	8.0	159	7.6	149		
10.2	185	7.0	190	7.0	190	7.1	190	6.7	177	6.3	166	6.0	156	5.7	148
6.5	142	4.6	150	4.8	155	5.0	160	4.8	155	4.6	145	4.4	137	4.2	129
102.2	297	64.6	280	58.9	254	53.2	228								
72.4	297	45.7	280	42.0	256	38.2	232	35.3	213	32.9	198				
53.5	297	33.8	280	31.2	257	28.5	234	26.6	217	24.8	202	23.3	189		
38.5	320	23.8	295	21.9	270	20.0	245	18.5	226	17.3	210				
30.3	333	19.5	320	18.0	295	16.6	269	15.4	250	14.5	233	13.6	218		
29.9	443	19.0	420	17.5	384	16.0	348	14.9	322						
22.8	433	14.5	410	13.4	377	12.4	345	11.5	319	10.8	297	10.2	278		
13.2	320	9.1	330	9.1	330	9.2	330	8.6	308	8.2	288	7.8	271		
209.5	615	132.3	580												
146.1	607	93.5	580	84.3	521	69.2	426								
107.9	607	69.0	580	62.9	526	52.2	436	53.2	442	49.6	410				
76.6	653	48.6	620	44.0	559	40.2	509								
58.2	653	37.0	620	33.7	564	31.1	516	28.8	477	26.8	442				
53.6	817	35.2	800	31.9	721										
41.0	820	26.1	780	23.9	708	19.9	587	20.4	597						
28.2	715	18.0	680	16.5	621	15.3	570	14.3	528	12.6	461				



Gearing efficiency of servo worm gear units with driving worm and under full load.

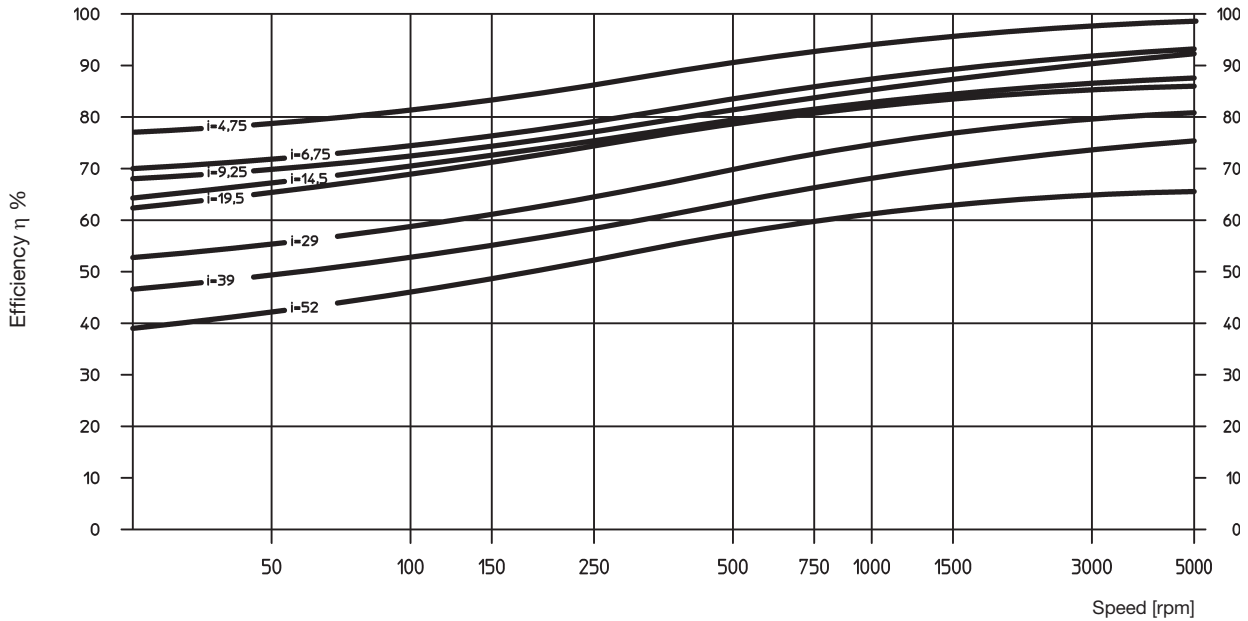

Additional loads on output drive

The data given are reference values. You should consider the values arising from the choice of the tooth system. It is assumed that the point of action of the force is the center of the shaft. In cases where additional axial forces occur, over and above high transverse forces, please ask for advice.

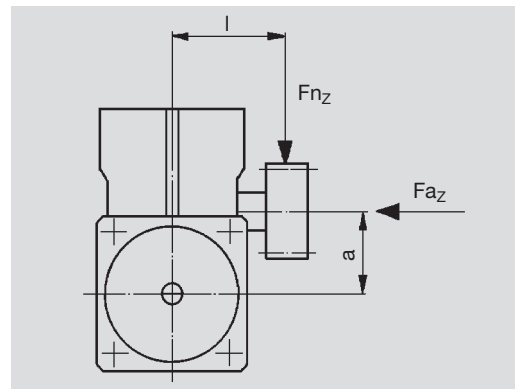

Center Distance	a (mm)		32		50		63		80		100	
Dimension center of casing to center of pinion	l (mm)		70	100	90	140	110	160	125	175	140	190
Max. additional load												
radial F_{n_z}	[N]		2250	1600	3600	2300	5000	3500	8400	6000	10000	7500
axial F_{a_z}	[N]		1500	1500	1800	1800	2500	2500	4000	4000	5000	5000



Short Description

ATLANTA E-servo worm gear units have been specially developed for use with the latest three-phase and DC servo-motors. Like all other components in this catalog, they are usually available ex stock or, at least, within a very short time.

The following are typical features of our E-servo gear units:

- the same dimensions as our HP Servo-Worm Gear Units
- low-clearance gearing (backlash < 5'),
- the same load values as our servo worm gear units serie 58
- casing of light metal for optimal heat dissipation
- robust bearings for the output drive hollow shaft, permitting greater additional forces.

Center distances, gear ratios and tooth systems have been chosen in accordance with DIN 3975/76.

The use of ground, right-hand worms, a worm gear of special worm-gear bronze and dip-feed lubrication (synthetic special oil) ensures a high degree of efficiency and also smooth running in both directions and a long service life. The casing with its many fixing bores and tapped holes permits mounting in any position.

The drive, i.e. the connection with the driving motor, is achieved with a special clutch. Its internal gearing, together with the barrelled profile of the driving shaft of our worm gear unit ensures transmission of the power with no free play.

For the output drive you can choose from quite a number of output drive shafts with straight and helical tooth systems and various numbers of teeth. Apart from pinion shafts there is a multitude of gearwheels with different numbers of teeth from our S & L gearwheel program which can be combined and used together with suitable special output drive shafts.

For emergency stops, the maximum transmittable torque of the gear unit (see page GC-14) and shrink disk (see page GH-1) has to be checked. The output keyway has to be calculated separately.





Mounting Instructions

Worm Gear Units

Five mounting faces with sufficiently dimensioned tapped holes are provided for mounting in any position. In order to accommodate all supplementary forces (see page GC-15) we recommend mounting at the largest contact faces., i.e. at one of the two cap sides. Putting the worm shaft (input shaft) in a lateral or inferior position is ideal for lubrication. Mounting the shaft in a top position will reduce the driving capacity by about 10 %.

Coupling

The coupling is supplied pre-assembled. All contact surfaces must be cleaned and protected by a thin oil film before attaching it to the motor shaft. An important dimension for mounting is the value „X1” (compare pages GI – 5 to GI –9).

Recommended procedure:

- Carefully clean the contact surfaces and protect them with a thin oil film.
- Place the coupling onto the motor shaft at the distance given by the measurement “X1” (see pages GI – 5 to GI –9); a depth gauge is helpful for determining the measurement.
- Slightly tighten the clamping screws and check the clutch for true running
- Tighten the screws alternately and uniformly.
- The correct tightening torque can be seen from the operation and maintenance instructions. The gap in the coupling must be equally wide on both sides.
- It is recommended to make another final check for true running at the appropriate reference diameter!

A mounting guide can be found on page GI-5 to GI-9

Motor

Insert the motor with coupling mounted into the gear centering piece and bolt it to the gearbox.

Output Pinion Shaft

Unless the output pinion shaft comes already fully assembled, we recommend to proceed as follows:

Clean pinion shaft and hollow shaft extension and then oil them. For the special output drive shaft we recommend tolerance h6 (DIN ISO286). the material must have a minimum yield point of 385 N/mm². A recalculation of the strength is necessary.

Output Drive Shaft for Shrink-Disk Connection

Slide shrink disk onto the hollow shaft extension of the gear unit (please do not tighten the screws beforehand!). Insert the output shaft from the desired side into the hollow shaft fully up to the stop. Make the transverse pressure connection by evenly tightening the clamping screws. Tighten the screws one after the other (not crosswise) in several passes to the torque indicated in the operation and maintenance instructions.

Output Drive Shaft for Key Connection

The retaining ring, the disk and the screw supplied with the output drive shaft serve for locking the output shaft in axial direction. For this purpose insert the retaining ring in the applicable recess of the hollow shaft and slide the output drive shaft from the desired side into the hollow shaft up to the stop. Disk and screw are screwed to the output shaft from the other side of the gear unit. The retaining ring must be clamped between disk and pinion shaft.





Maintenance

Lubricant Change

ATLANTA servo worm-gear units are filled with synthetic polyglycol oil.

Under the following conditions this means lifetime lubrication:

The layout of the gear unit is made strictly in conformance with the guidelines specified in the ATLANTA catalog and the gear unit is operated exclusively within the permissible characteristic values and limits. The operator checks the gear unit regularly (every 4 weeks) for oil leakage. The surface temperature does not exceed max. 80° C. Experience has shown that this temperature is not reached with servo-operation (intermittent operation).

In the case of an operation with mainly low input speeds (circumferential speed of the worm $v < 0.5$ m/s) we recommend to change the lubricant every two years.



Center Distance	Oil Quantity
a = 32 mm	0.07 l
a = 50 mm	0.40 l
a = 63 mm	0.70 l
a = 80 mm	1.70 l
a = 100 mm	2.00 l

We recommend the following synthetic gear lubricant:

Klübersynth GH 6 - 220

Order code: 65 90 010 (1 liter)

Alternative:

SHELL Tivela S 220, BP Enersyn SG-XP 220, ARAL Degol GS 220

Degree of Protection

Degree of protection: IP65/67 according to ISO 20653
(Corrosion has to be verified separately).



	Page
B Basic Gear Units with <12' Backlash	GD2 – GD5
Center Distance 50 mm	GD2 – GD3
Center Distance 63 mm	GD4 – GD5
Couplings and Shrink-Disk	GD6 – GD7
Selection and Load Tables	GD8 – GD10
Short Description	GD11
Mounting and Maintenance	GD12 – GD13
Gear Units Calculation and Selection	GF1 – GF3
Gear Units Accessories	GG1 – GG9
Mounting Guide for Servo Gears	GI5 – GI9





Center Distance

$a_o = 50 \text{ mm}$

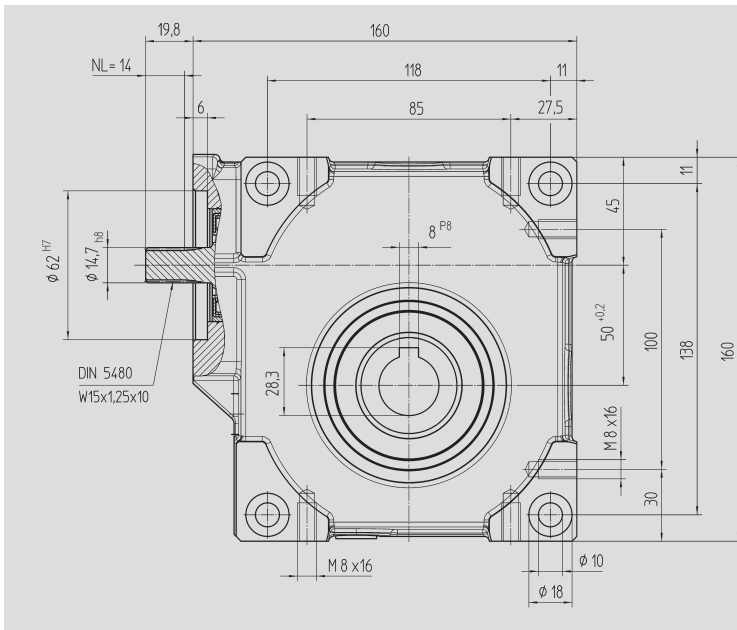

Fig. 1 Output shaft with key connection

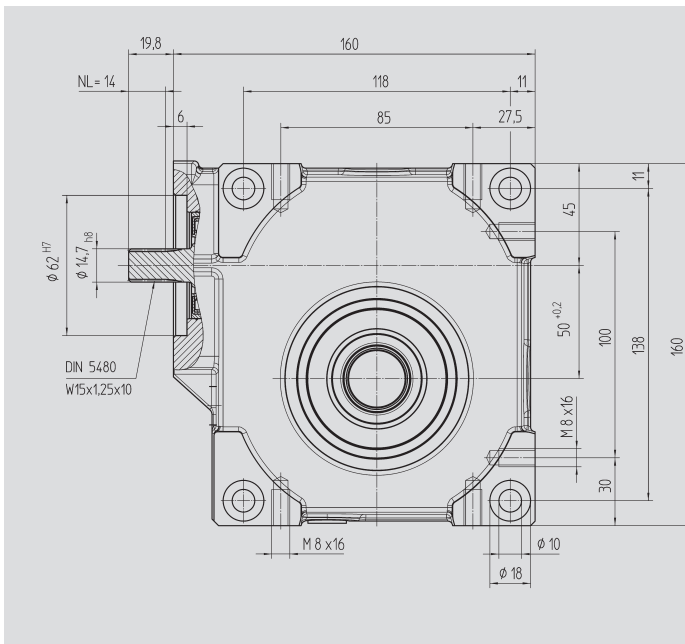
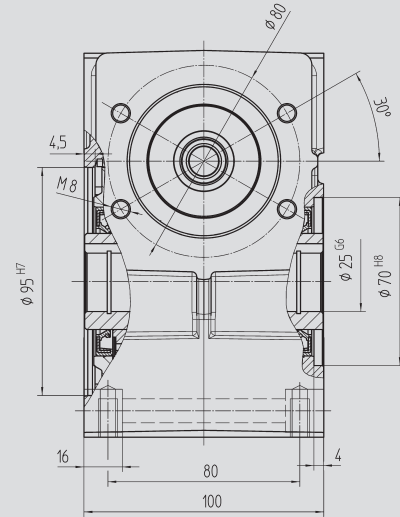
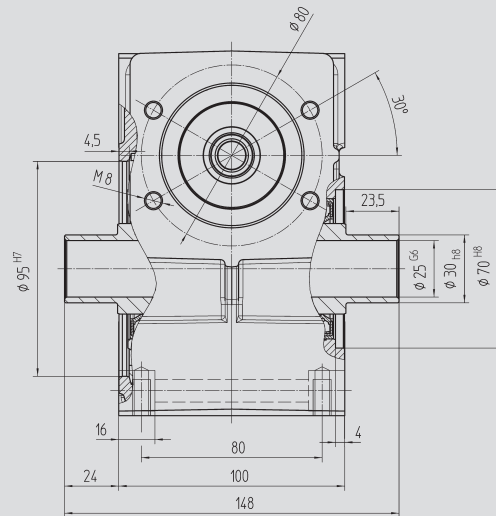

Fig. 2 Output shaft for clamp connection 80 83 030



Order Code Fig. 1	Fig. 2	Ratio i	kg	$J_{red} 10^{-4}$ kg m ²
57 03 005	57 13 005	4.75	6.5	0.8280
57 03 007	57 13 007	6.75	6.5	0.4140
57 03 009	57 13 009	9.25	6.5	0.3490
57 03 015	57 13 015	14.50	6.5	0.2800
57 03 020	57 13 020	19.50	6.5	0.1960
57 03 029	57 13 029	29.00	6.5	0.2694
57 03 039	57 13 039	39.00	6.5	0.2310
57 03 050	57 13 050	50.00	6.5	0.2140

With food grade oil, order code 57 03 1xx / 57 13 1xx



Motor Flange

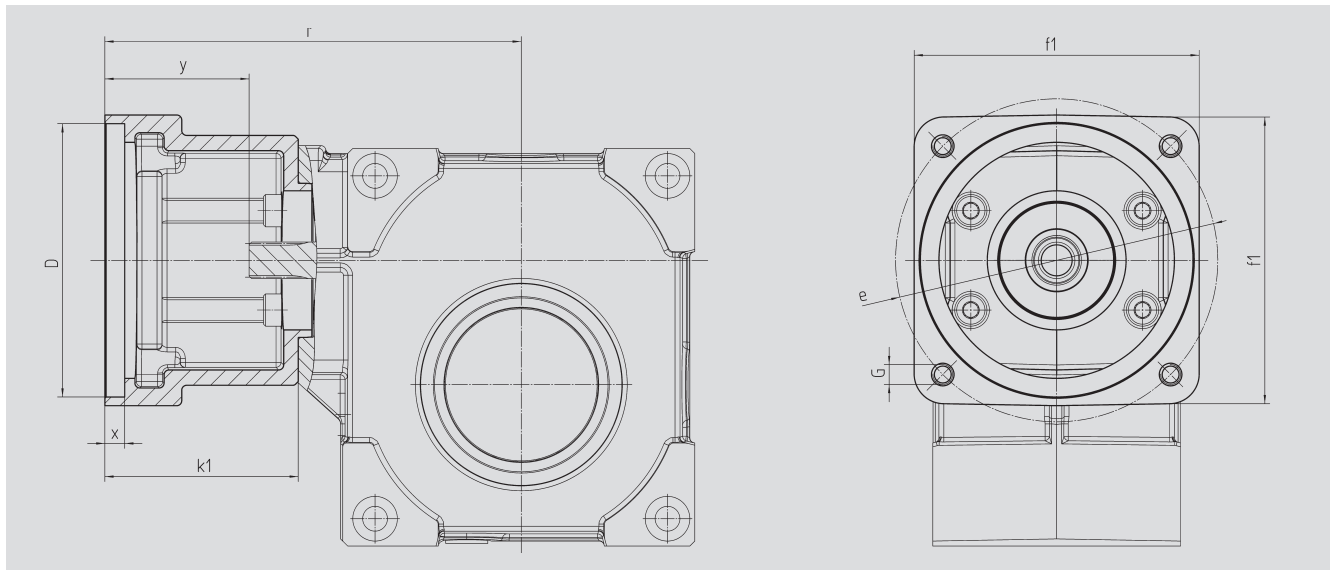

Center Distance

$a_o = 50 \text{ mm}$

Order Code	D ^{G7}	k ₁	r	x	y	f ₁	e	G	kg
65 59 301	95.0	62	152	12.5	42	100	115	M8	0.60
65 59 302	50.0	62	152	10.0	42	100	70, 95, 115	M4, M6, M8	0.70
65 59 303	80.0	62	152	10.0	42	100	100	M6	0.65
65 59 304	95.0	78	168	10.0	59	115	130	M8	0.80
65 59 305	95.0	72	162	8.0	52	100	115	M8	0.75
65 59 306	60.0	74	164	21.0	54	100	75, 90, 115	M5, M5, M8	0.90
65 59 307	70.0	70	160	21.0	50	100	90, 115	M6, M8	0.80
65 59 401	95.0	73	163	8.0	53	100	115	M8	0.75
65 59 402	110.0	78	168	8.0	59	115	130	M8	0.80
65 59 403	95.0	73	163	12.0	53	115	130	M8	0.75
65 59 404	110.0	73	163	12.0	53	115	130	M8	0.70
65 59 405	95.0	78	168	11.0	59	140	165	M10	1.20
65 59 406	110.0	78	168	11.0	59	140	165	M10	1.15
65 59 407	130.0	78	168	11.0	59	140	165	M10	1.00
65 59 409	130.0	98	188	14.0	78	140	165	M10	1.10
65 59 410	110.0	74	164	8.0	54	120	145	M8	1.00
65 59 411	110.0	84	174	8.0	64	120	145	M8	1.20
65 59 412	114.3	105	195	8.0	85	180	200	M12	3.70
65 59 413	114.3	139	229	8.0	119	180	200	M12	3.35
65 59 414	114.3	91	181	8.0	71	180	200	M12	2.65
65 59 415	110.0	89	179	8.0	69	120	145	M8	1.30

The order should contain gear box 57 03 0xx / 57 13 0xx and flange 65 59 3xx or 4xx.



Center Distance

$a_o = 63 \text{ mm}$

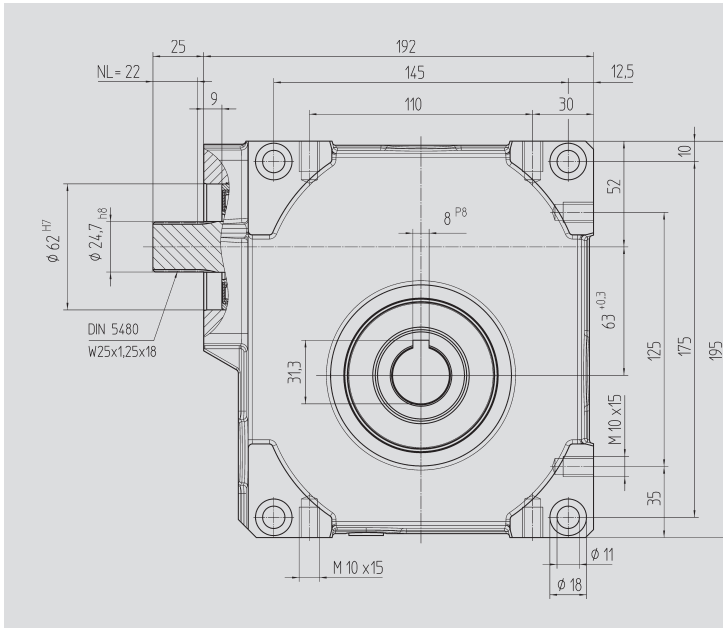

Fig. 1 Output shaft with key connection

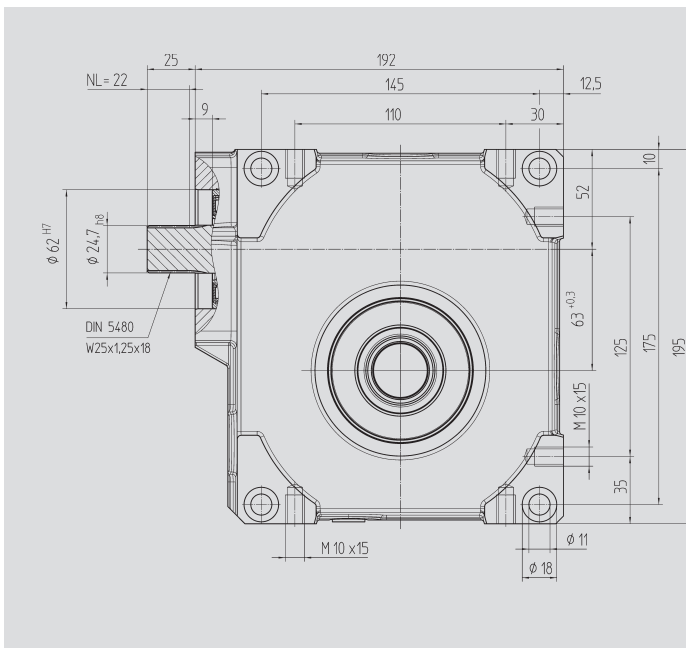
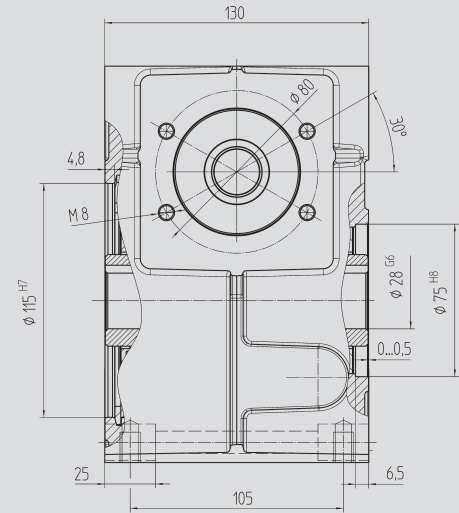
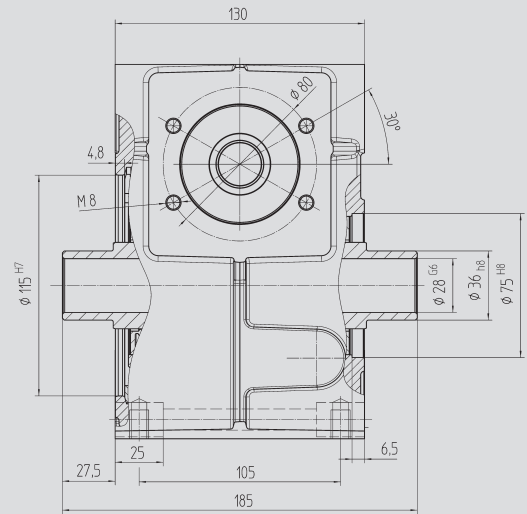

Fig. 2 Output shaft for clamp connection 80 84 036



Order Code Fig. 1	Fig. 2	Ratio i	kg	$J_{red} 10^{-4}$ kg m ²
57 04 005	57 14 005	4.75	11.5	2.5350
57 04 007	57 14 007	6.75	11.5	1.3720
57 04 009	57 14 009	9.25	11.5	0.9825
57 04 015	57 14 015	14.50	11.5	0.9570
57 04 020	57 14 020	19.50	11.5	0.6940
57 04 029	57 14 029	29.00	11.5	0.9966
57 04 039	57 14 039	39.00	11.5	1.0100
57 04 052	57 14 052	52.00	11.5	0.5305

With food grade oil, order code 57 04 1xx / 57 14 1xx



Motor Flange

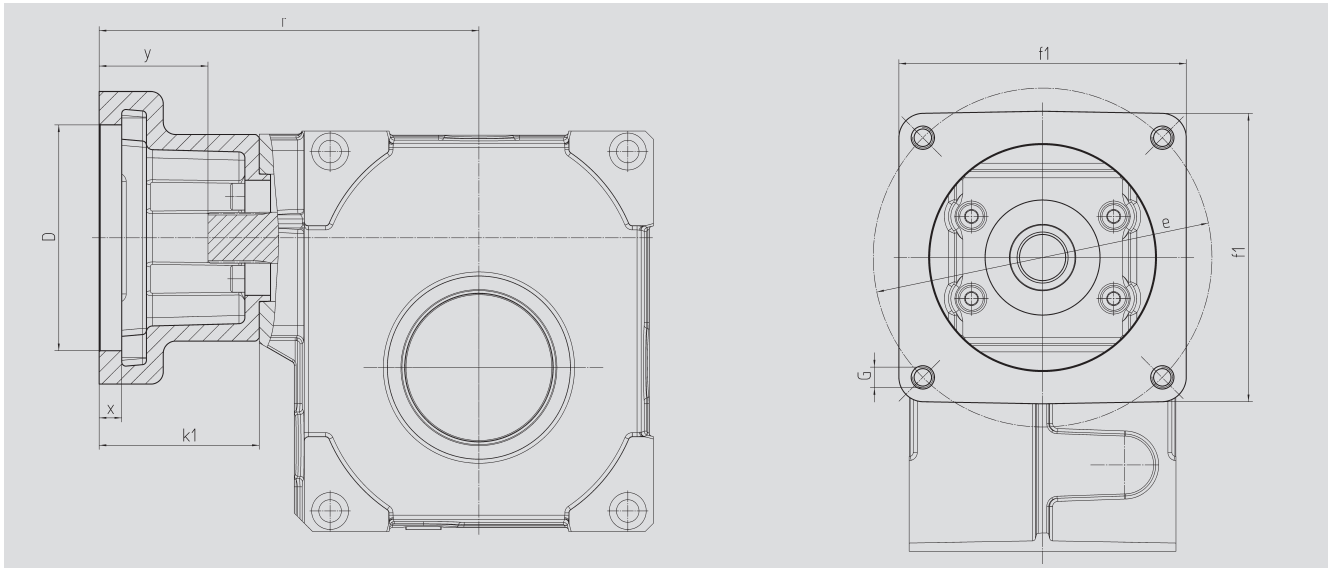

Center Distance

$a_o = 63 \text{ mm}$

Order Code	D ^{G7}	k ₁	r	x	y	f ₁	e	G	kg
65 59 301	95.0	62	169	12.5	37	100	115	M8	0.60
65 59 302	50.0	62	169	10.0	37	100	70, 95, 115	M4, M6, M8	0.70
65 59 303	80.0	62	169	10.0	37	100	100	M6	0.65
65 59 304	95.0	78	185	10.0	53	115	130	M8	0.80
65 59 305	95.0	72	179	8.0	47	100	115	M8	0.75
65 59 306	60.0	74	181	21.0	49	100	75, 90, 115	M5, M5, M8	0.90
65 59 307	70.0	70	177	21.0	45	100	90, 115	M6, M8	0.80
65 59 401	95.0	73	180	8.0	48	100	115	M8	0.75
65 59 402	110.0	78	185	8.0	53	115	130	M8	0.80
65 59 403	95.0	73	180	12.0	48	115	130	M8	0.75
65 59 404	110.0	73	180	12.0	48	115	130	M8	0.70
65 59 405	95.0	78	185	11.0	53	140	165	M10	1.20
65 59 406	110.0	78	185	11.0	53	140	165	M10	1.15
65 59 407	130.0	78	185	11.0	53	140	165	M10	1.00
65 59 409	130.0	98	205	14.0	73	140	165	M10	1.10
65 59 410	110.0	74	181	8.0	49	120	145	M8	1.00
65 59 411	110.0	84	191	8.0	59	120	145	M8	1.20
65 59 412	114.3	105	212	8.0	80	180	200	M12	3.70
65 59 413	114.3	139	246	8.0	114	180	200	M12	3.35
65 59 414	114.3	91	198	8.0	66	180	200	M12	2.65
65 59 415	110.0	89	196	8.0	64	120	145	M8	1.30

The order should contain gear box 57 04 0xx / 57 14 0xx and flange 65 59 3xx or 4xx.



Special Couplings for Motor/Gear Units, rigid model, nitrided, preassembled for motor shafts without key

Bore on gear unit side
low-clearance tooth-hub
profile corresponding to
DIN 5480 for push-fitting

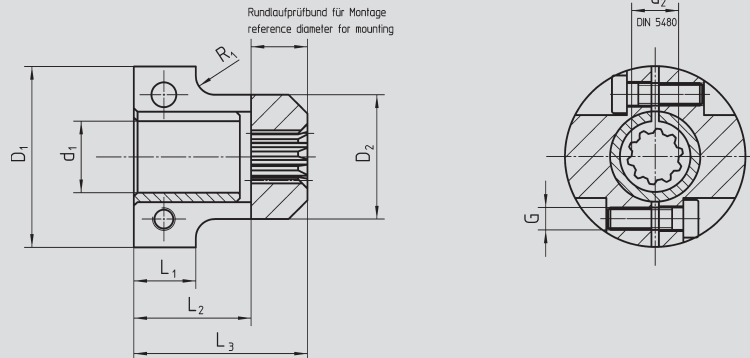

< 12 arcmin

Order Code

Coupling	d ₁	d ₂	D ₁	D ₂	L ₁	L ₃	R ₁	G	L ₂	J _{red} 10 ⁻⁴ kg m ²	kg
65 51 008	8	15x1.25x10	36	23	14.0	46.0	5	M5	31.2	0.236	0.2
65 51 009	9	15x1.25x10	36	23	14.0	46.0	5	M5	31.2	0.246	0.2
65 51 010	10	15x1.25x10	36	23	14.0	46.0	5	M5	31.2	0.244	0.2
65 51 011	11	15x1.25x10	36	23	14.0	46.0	5	M5	31.2	0.243	0.2
65 51 014	14	15x1.25x10	36	23	14.0	46.0	5	M5	31.2	0.234	0.2
65 51 016	16	15x1.25x10	36	23	14.0	46.0	5	M5	31.2	0.225	0.2
65 53 019	19	15x1.25x10	48	33	16.5	46.0	5	M5	31.2	0.704	0.3
65 53 020	20	15x1.25x10	48	33	16.5	46.0	5	M6	31.2	0.704	0.3
65 53 022	22	15x1.25x10	48	33	16.5	46.0	5	M5	31.2	0.704	0.3
65 53 024	24	15x1.25x10	48	33	16.5	46.0	5	M5	31.2	0.647	0.2
65 53 025	25	15x1.25x10	64	51	18.0	55.5	5	M8	41.5	5.946	1.1
65 53 028	28	15x1.25x10	64	51	18.0	55.5	5	M8	41.5	5.871	1.1
65 53 032	32	15x1.25x10	64	51	18.0	55.5	5	M8	41.5	4.158	0.8
65 53 035	35	15x1.25x10	78	51	18.0	55.5	5	M8	41.5	5.605	1.0
65 53 038	38	15x1.25x10	78	51	18.0	55.5	5	M8	41.5	5.432	0.9
65 54 009	9	25x1.25x18	49	35	17.0	68.0	5	M6	43.5	2.306	0.5
65 54 010	10	25x1.25x18	49	35	17.0	68.0	5	M6	43.5	2.300	0.5
65 54 011	11	25x1.25x18	49	35	17.0	68.0	5	M6	43.5	2.381	0.5
65 54 014	14	25x1.25x18	49	35	17.0	68.0	5	M6	43.5	1.161	0.5
65 54 015	15	25x1.25x18	49	35	17.0	68.0	5	M6	43.5	2.328	0.5
65 54 016	16	25x1.25x18	49	35	17.0	68.0	5	M6	43.5	1.161	0.5
65 54 019	19	25x1.25x18	49	35	17.0	68.0	5	M6	43.5	1.112	0.4
65 54 020	20	25x1.25x18	49	35	17.0	68.0	5	M6	43.5	2.268	0.5
65 54 022	22	25x1.25x18	49	35	17.0	68.0	5	M6	43.5	2.179	0.4
65 54 024	24	25x1.25x18	49	35	17.0	68.0	5	M6	43.5	1.007	0.4
65 54 025	25	25x1.25x18	64	51	18.0	68.0	5	M8	43.5	8.165	1.2
65 54 028	28	25x1.25x18	64	51	18.0	68.0	5	M8	43.5	8.061	1.2
65 54 032	32	25x1.25x18	64	51	18.0	68.0	5	M8	43.5	7.751	1.2
65 54 035	35	25x1.25x18	78	51	18.0	68.0	5	M8	43.5	7.690	1.1
65 54 038	38	25x1.25x18	78	51	18.0	68.0	5	M8	43.5	7.348	1.1
65 54 042	42	25x1.25x18	78	51	18.0	65.5	5	M8	43.5	6.595	1.1

Couplings on page GA-10 can be used as well.



Shrink-Disk Clamping Sets for Output Drive Shafts of gear series 57 1. ...

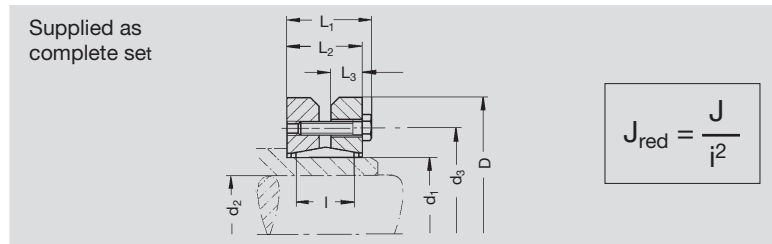

< 12 arcmin

Order Code	mm	Nm	d ₁	d ₂	d ₃	D	L ₁	L ₂	L ₃	l	G	J 10 ⁻⁴ kg m ²	kg
80 83 030	50	400	30	25	44	60	25.0	21.5	9	16	7 x M5	1.756	0.3
80 84 036	63	540	36	28	52	72	27.5	23.5	10	18	5 x M6	4.029	0.4



The values in the tables are based upon wear or maximum flank load at 12,000 hours full load and on servo-operation. With continuous full-load operation it may be necessary to consider temperature limits! (Please ask us if in doubt.)

T_{2max} = static torque to avoid tooth fracture. T_1 = input torque in Nm. T_2 = output torque in Nm.



Order Code	a_0 (mm)	i	T_{2max}	Input Speed n_1 (rpm)											
				250		500		750		1000		1500		2000	
				T_1 (Nm)	T_2 (Nm)	T_1 (Nm)	T_2 (Nm)	T_1 (Nm)	T_2 (Nm)	T_1 (Nm)	T_2 (Nm)	T_1 (Nm)	T_2 (Nm)	T_1 (Nm)	T_2 (Nm)
57 03 003 57 13 003	50	3.00		0											
57 03 005 57 13 005		4.75	495	10.5	44	13.8	59	13.8	59	14.7	63	14.8	63	14.9	63
57 03 007 57 13 007		6.75	360	6.5	38	8.6	51	8.9	53	9.5	57	10.3	62	10.3	62
57 03 009 57 13 009		9.25	248	4.3	32	5.8	44	5.9	46	6.3	49	6.8	53	7.1	56
57 03 015 57 13 015		14.50	315	3.4	39	4.3	51	4.5	54	4.9	59	5.2	63	5.4	65
57 03 020 57 13 020		19.50	225	2.2	30	2.8	41	3.0	44	3.0	45	3.4	50	3.5	53
57 03 029 57 13 029		29.00	270	1.8	33	2.2	44	2.3	47	2.5	50	2.6	54	2.8	57
57 03 039 57 13 039		39.00	180	1.7	35	2.0	47	2.2	51	2.3	54	2.4	59	2.6	62
57 03 052 57 13 052		52.00	135	1.4	29	1.6	38	1.6	40	1.7	42	1.8	45	1.9	48
57 04 003 57 14 003	63	3.00													
57 04 005 57 14 005		4.75	900	33.9	147	35.0	153	37.1	162	37.2	162	35.2	153	33.8	146
57 04 007 57 14 007		6.75	675	19.5	117	25.1	153	26.5	162	26.5	162	25.1	153	24.1	146
57 04 009 57 14 009		9.25	450	9.8	77	12.9	104	13.9	113	14.3	117	14.9	122	14.9	122
57 04 015 57 14 015		14.50	540	10.1	119	12.3	149	13.3	162	13.3	162	13.3	162	13.0	159
57 04 020 57 14 020		19.50	450	5.1	78	6.5	104	7.0	113	7.2	117	7.5	122	8.1	131
57 04 029 57 14 029		29.00	585	6.2	124	7.6	158	8.2	171	8.8	185	9.4	198	9.1	191
57 04 039 57 14 039		39.00	405	3.8	96	4.7	126	4.9	135	5.3	144	5.8	158	5.9	162
57 04 051 57 14 051		52.00	270	2.2	64	2.7	86	3.0	95	3.2	104	3.4	113	3.6	120

* On request



Input Speed n_1 (rpm)															
2500		3000		3500		4000		4500		5000		5500		6000	
T_1 (Nm)	T_2 (Nm)	T_1 (Nm)	T_2 (Nm)	T_1 (Nm)	T_2 (Nm)	T_1 (Nm)	T_2 (Nm)	T_1 (Nm)	T_2 (Nm)	T_1 (Nm)	T_2 (Nm)	T_1 (Nm)	T_2 (Nm)	T_1 (Nm)	T_2 (Nm)
15.0	63	15.1	63	14.8	61	14.4	59	14.1	57	13.7	55	13.1	52	12.4	49
10.4	62	10.6	63	10.1	60	10.0	59	9.8	57	9.5	55	9.0	52	8.6	49
7.6	60	8.0	63	8.0	63	8.0	63	7.8	61	7.6	59	7.2	55	6.8	52
5.5	66	5.7	68	5.7	68	5.7	68	5.8	68	5.8	68	5.5	64	5.2	60
3.7	56	3.9	59	3.9	59	3.9	59	4.0	59	4.0	59	3.8	55	3.6	52
3.0	60	3.1	63	3.1	63	3.2	63	3.1	61	3.0	59	2.9	55	2.7	52
2.7	65	2.8	68	2.8	68	2.8	68	2.8	68	2.9	68	2.7	64	2.6	60
2.0	51	2.1	54	2.1	54	2.1	54	2.1	54	2.1	54	2.2	56	2.2	58
32.1	138	30.7	131	29.7	126	28.9	122	26.7	112	24.9	104				
22.9	138	21.8	131	21.1	126	20.5	122	19.2	113	17.9	105	16.8	98		
14.9	122	14.9	122	14.5	118	14.1	114	13.2	106	12.5	100	11.8	94	11.3	89
12.8	156	12.7	153	12.4	149	12.1	144	11.3	134	10.6	125	10.0	117		
8.7	140	9.3	149	9.0	144	8.8	140	8.2	130	7.8	123	7.4	116	7.0	109
8.8	183	8.5	176	8.4	171	8.2	167	7.7	154	7.2	144	6.8	134		
6.1	167	6.3	171	6.3	171	6.4	171	6.0	160	5.7	150	5.4	141	5.2	133
3.9	128	4.1	135	4.3	140	4.5	144	4.4	140	4.1	131	4.0	124	3.8	117





Gearing efficiency of servo worm gear units with driving worm and under full load.

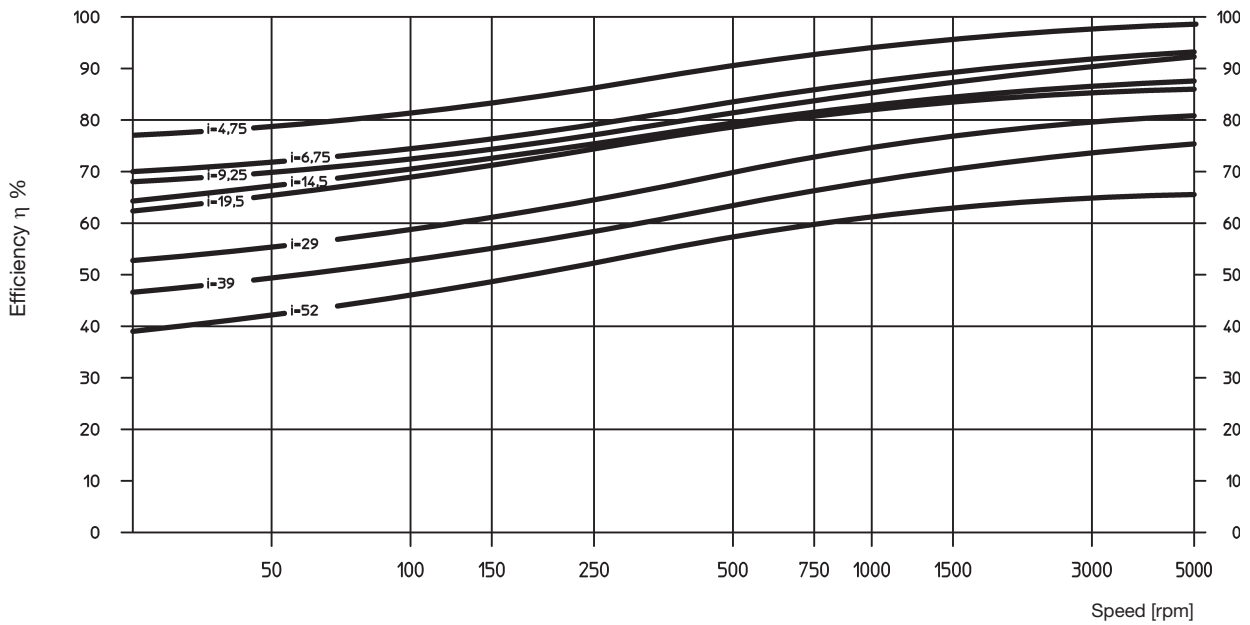

Additional loads on output drive

The data given are reference values. You should consider the values arising from the choice of the tooth system. It is assumed that the point of action of the force is the center of the shaft. In cases where additional axial forces occur, over and above high transverse forces, please ask for advice.

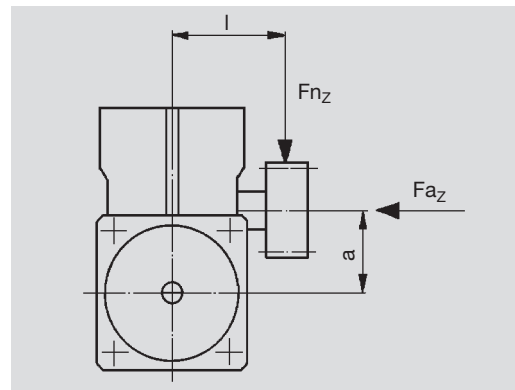

Center Distance	a (mm)	50		63	
Dimensions center of casing to center of pinion					
l (mm)		90	140	110	160
Max. additional load					
radial F_{n_z}	[N]	2500	1600	3500	2450
axial F_{a_z}	[N]	1250	1250	1750	1750



Short Description

ATLANTA B-servo worm gear units have been specially developed for use with the latest three-phase and DC servo-motors. Like all other components in this catalog, they are usually available ex stock or, at least, within a very short time.

The following are typical features of our B-servo gear units:

- the same dimensions as our servo worm gear units serie 59
- low-clearance gearing (backlash < 12'),
- casing of light metal for optimal heat dissipation
- robust bearings for the output drive hollow shaft, permitting additional forces.

Center distances, gear ratios and tooth systems have been chosen in accordance with DIN 3975/76.

The use of ground, right-hand worms, a worm gear of special worm-gear bronze and dip-feed lubrication (synthetic special oil) ensures a high degree of efficiency and also smooth running in both directions and a long service life. The casing with its many fixing bores and tapped holes permits mounting in any position.

The drive, i.e. the connection with the driving motor, is achieved with a special clutch. Its internal gearing, together with the barrelled profile of the driving shaft of our worm gear unit ensures transmission of the power with no free play.

For the output drive you can choose from quite a number of output drive shafts with straight and helical tooth systems and various numbers of teeth. Apart from pinion shafts there is a multitude of gearwheels with different numbers of teeth from our S & L gearwheel program which can be combined and used together with suitable special output drive shafts.

For emergency stops, the maximum transmittable torque of the gear unit (see page GD-14) and shrink disk (see page GH-1) has to be checked. The output keyway has to be calculated separately.





Mounting Instructions

Worm Gear Units

Five mounting faces with sufficiently dimensioned tapped holes are provided for mounting in any position. In order to accommodate all supplementary forces (see page GD-15) we recommend mounting at the largest contact faces., i.e. at one of the two cap sides. Putting the worm shaft (input shaft) in a lateral or inferior position is ideal for lubrication. Mounting the shaft in a top position will reduce the driving capacity by about 10%.

Coupling

The coupling is supplied pre-assembled. All contact surfaces must be cleaned and protected by a thin oil film before attaching it to the motor shaft. An important dimension for mounting is the value „X1” (compare pages GI – 5 to GI – 9).

Recommended procedure:

- Carefully clean the contact surfaces and protect them with a thin oil film.
- Place the coupling onto the motor shaft at the distance given by the measurement “X1” (see pages GI – 5 to GI – 9); a depth gauge is helpful for determining the measurement.
- Slightly tighten the clamping screws and check the clutch for true running
- Tighten the screws alternately and uniformly.
- The correct tightening torque can be seen from the operation and maintenance instructions. The gap in the coupling must be equally wide on both sides.
- It is recommended to make another final check for true running at the appropriate reference diameter!

A mounting guide can be found on page GI-5 to GI-9.

Motor

Insert the motor with coupling mounted into the gear centering piece and bolt it to the gearbox.

Output Pinion Shaft

Unless the output pinion shaft comes already fully assembled, we recommend to proceed as follows:

Clean pinion shaft and hollow shaft extension and then oil them. For the special output drive shaft we recommend tolerance h6 (DIN ISO286). the material must have a minimum yield point of 385 N/mm². A recalculation of the strength is necessary.

Output Drive Shaft for Shrink-Disk Connection

Slide shrink disk onto the hollow shaft extension of the gear unit (please do not tighten the screws beforehand!). Insert the output shaft from the desired side into the hollow shaft fully up to the stop. Make the transverse pressure connection by evenly tightening the clamping screws. Tighten the screws one after the other (not crosswise) in several passes to the torque indicated in the operation and maintenance instructions.

Output Drive Shaft for Key Connection

The retaining ring, the disk and the screw supplied with the output drive shaft serve for locking the output shaft in axial direction. For this purpose insert the retaining ring in the applicable recess of the hollow shaft and slide the output drive shaft from the desired side into the hollow shaft up to the stop. Disk and screw are screwed to the output shaft from the other side of the gear unit. The retaining ring must be clamped between disk and pinion shaft.





Maintenance

Lubricant Change

ATLANTA B-servo-worm-gear units are filled with synthetic polyglycol oil.

Under the following conditions this is a lifetime lubrication:

The layout of the gear unit is made strictly in conformance with the guidelines specified in the ATLANTA catalog and the gear unit is operated exclusively within the permissible characteristic values and limits. The operator checks the gear unit regularly (every 4 weeks) for oil leakage. The surface temperature does not exceed max. 80° C. Experience has shown that this temperature is not reached with servo-operation (intermittent operation).

In the case of an operation with mainly low input speeds (circumferential speed of the worm $v < 0.5$ m/s) we recommend to change the lubricant every two years.



Center Distance	Oil Quantity
a = 50 mm	0.25 l
a = 63 mm	0.60 l

We recommend the following synthetic gear lubricant:

Klübersynth GH 6 - 220

Order code: 65 90 010 (1 liter)

Alternative:

SHELL Tivela S 220, BP Enersyn SG-XP 220, ARAL Degol GS 220

Degree of Protection

Degree of protection: IP65/67 according to ISO 20653

(Corrosion has to be verified separately).



	Page
BG Bevel-Gear Units with <6' Backlash	
Size 50	GE2 – GE3
Size 63	GE4 – GE5
Size 80	GE6 – GE7
Couplings and Shrink-Disks	GE8 – GE9
Selection and Load Tables	GE10
Short Description	GE11
Mounting and Maintenance	GE12 – GE13
Motor Applications	GI5 – GI9





Size BG 50

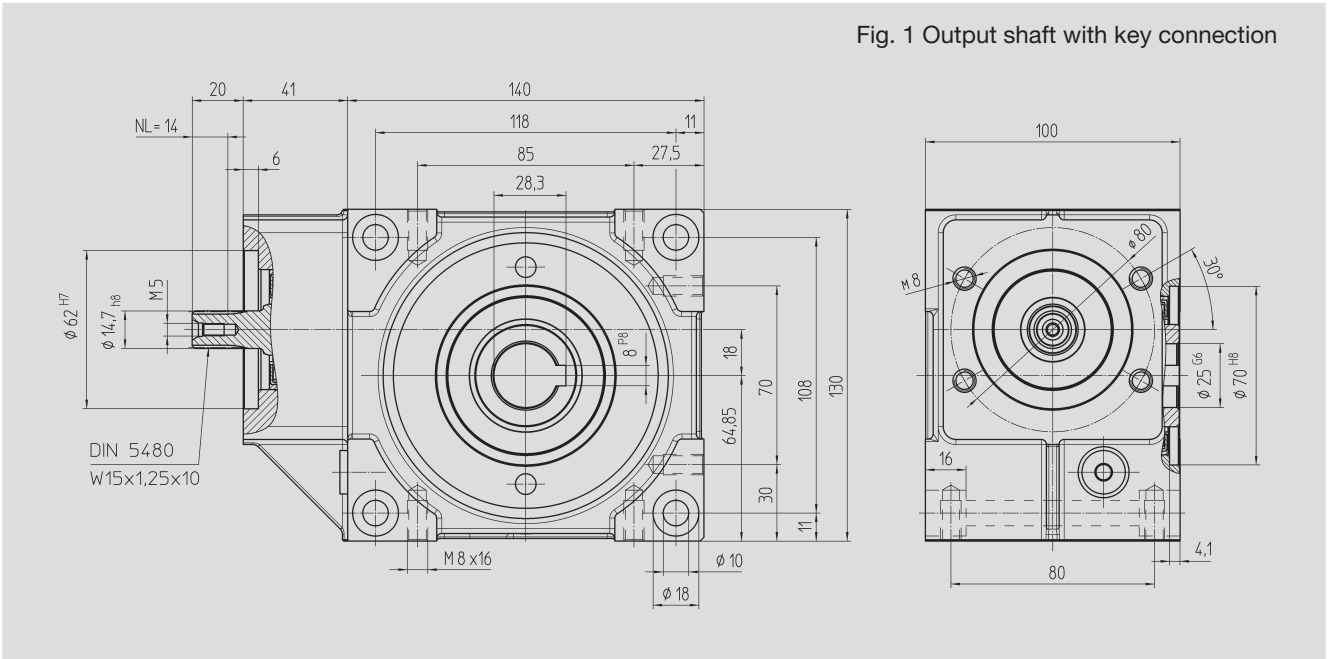

Size BG 50

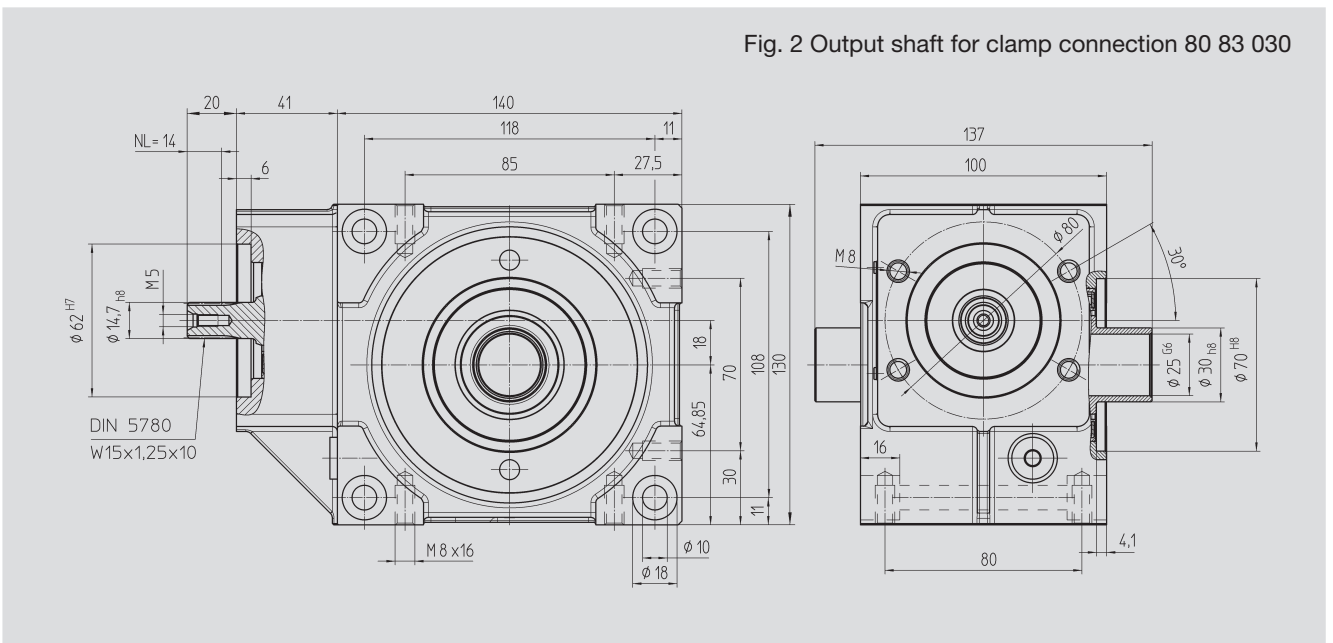

Order Code	Order Code	Ratio i	T _{kg}	J _{red} 10 ⁻⁴ kg m ²
Fig. 1	Fig. 2			
51 23 005	51 33 005	4.75	6.3	0.576
51 23 007	51 33 007	6.75	6.3	0.330
51 23 009	51 33 009	9.25	6.3	0.194

With food grade oil, order code 51 23 1xx / 51 33 1xx. With ATEX version with food grade oil, order code 51 23 2xx / 51 33 2xx.



Motor Flange

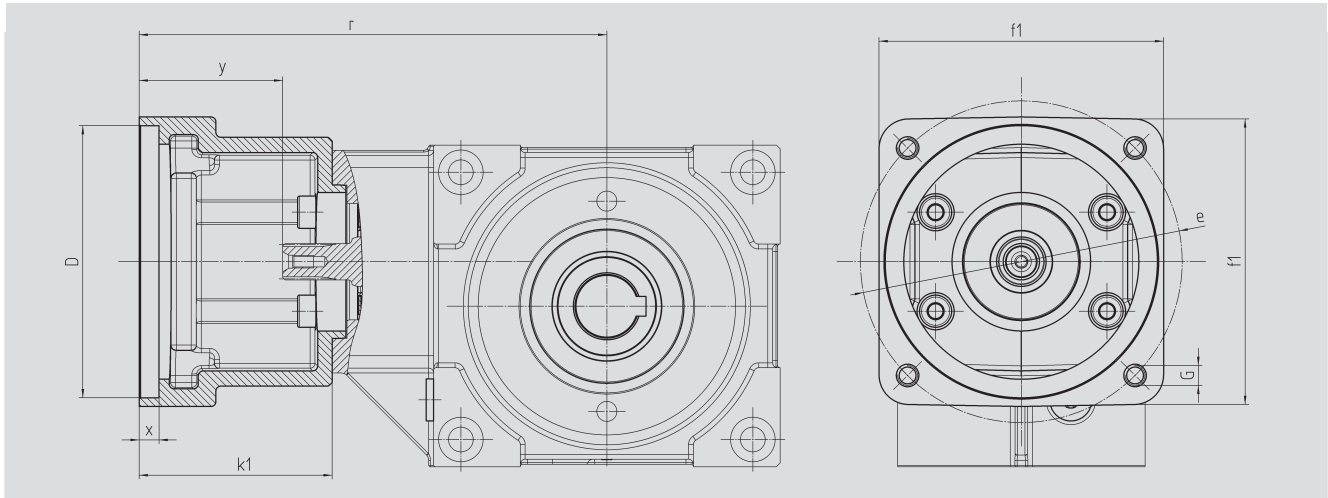

Size 50 mm

Order Code	D ^{G7}	k ₁	r	x	y	f ₁	e	G	T kg
65 59 301	95.0	62	173	6	42	100	115	M8	1.0
65 59 302	50.0	62	173	6	42	100	70, 95, 115	M4,M6,M8	1.0
65 59 303	80.0	62	173	6	42	100	100	M6	1.0
65 59 304	95.0	78	189	6	58	115	130	M8	1.0
65 59 305	95.0	72	183	5	52	105	115	M8	1.0
65 59 306	60.0	74	184	7	54	100	75, 90, 115	M5,M5,M8	1.0
65 59 307	70.0	70	181	7	50	100	90, 115	M6,M8	1.0
65 59 401	95.0	73	184	7	53	100	115	M8	1.0
65 59 402	110.0	78	189	7	58	115	130	M8	1.0
65 59 403	95.0	73	184	7	53	115	130	M8	1.0
65 59 404	110.0	73	184	7	53	115	130	M8	1.0
65 59 405	95.0	78	189	7	58	140	165	M10	1.0
65 59 406	110.0	78	189	7	58	140	165	M10	1.0
65 59 407	130.0	78	189	7	58	140	165	M10	1.0
65 59 409	130.0	98	209	7	78	140	165	M10	1.5
65 59 410	110.0	74	185	7	54	120	145	M8	1.0
65 59 411	110.0	84	195	7	64	120	145	M8	1.5
65 59 412	114.3	105	216	7	85	180	200	M12	3.5
65 59 413	114.3	139	150	7	119	180	200	M12	6.0
65 59 414	114.3	91	202	7	71	180	200	M12	2.5
65 59 415	110.0	89	200	7	69	120	145	M8	1.5

The order should contain gear box 51 23 0xx / 51 33 0xx and flange 65 59 3xx or 4xx.



Size BG 63

Fig. 1 Output shaft with key connection

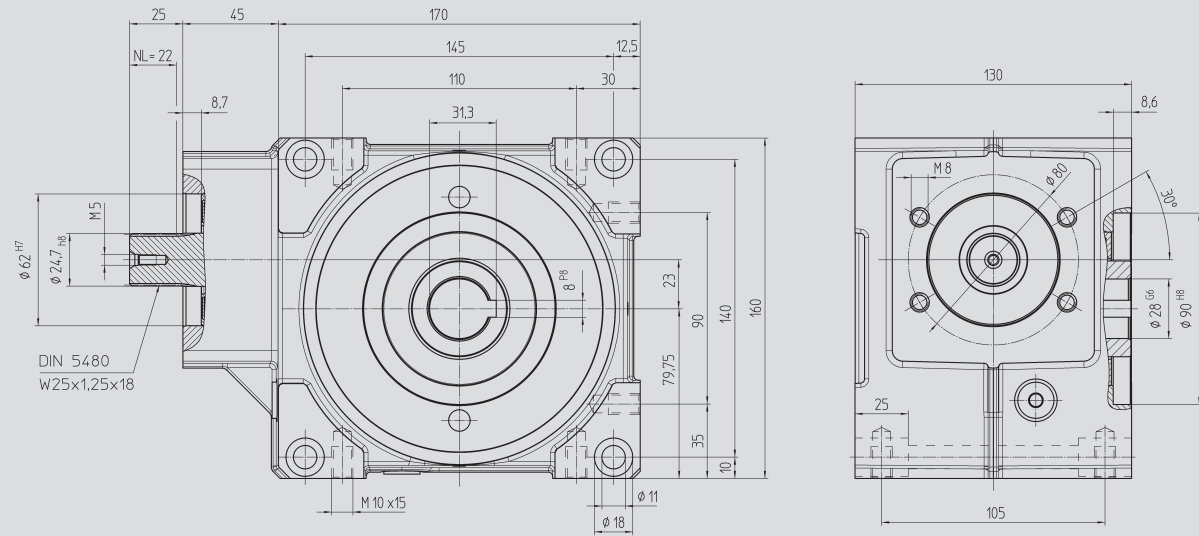

Size BG 63

Fig. 2 Output shaft for clamp connection 80 84 036

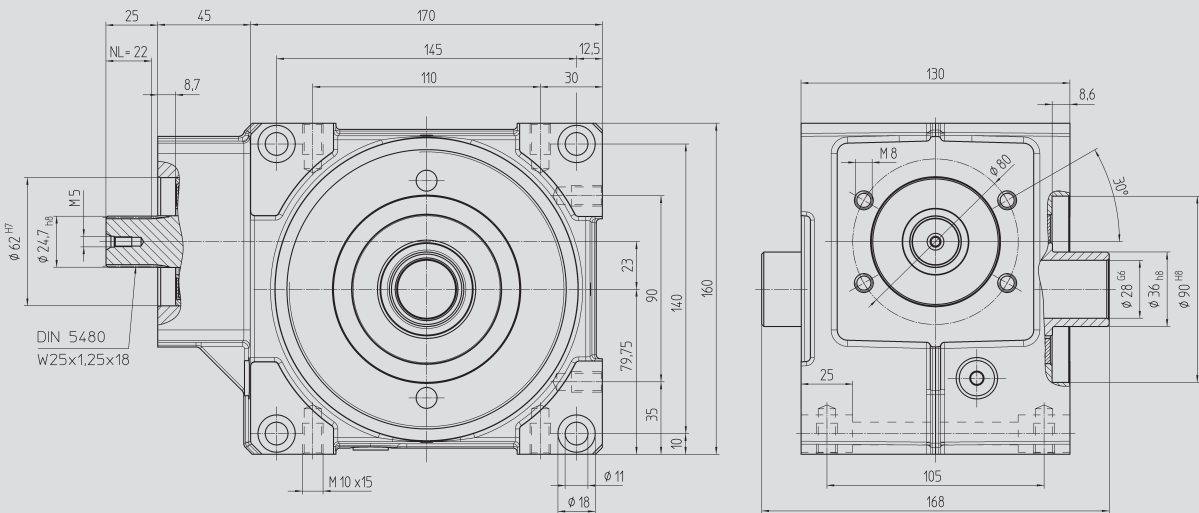

Order Code	Order Code	Ratio i	J_{red} kg	$J_{red} 10^{-4}$ kg m ²
Fig. 1	Fig. 2			
51 24 005	51 34 005	4.75	10.2	1.870
51 24 007	51 34 007	6.75	10.2	1.180
51 24 009	51 34 009	9.25	10.2	0.683

With food grade oil, order code 51 24 1xx / 51 34 1xx. With ATEX version with food grade oil, order code 51 24 2xx / 51 34 2xx.



Motor Flange

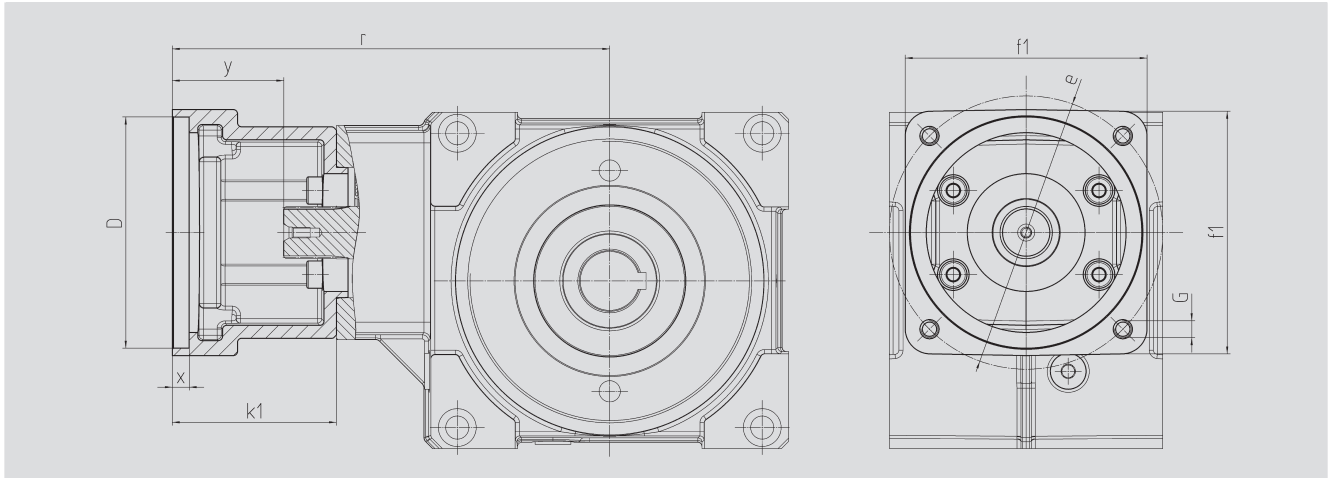

Size 63 mm

Order Code	D ^{G7}	k ₁	r	x	y	f ₁	e	G	kg
65 59 301	95.0	62	192	6	37	100	115	M8	1.0
65 59 302	50.0	62	192	6	37	100	70, 95, 115	M4,M6,M8	1.0
65 59 303	80.0	62	192	6	37	100	100	M6	1.0
65 59 304	95.0	78	208	6	53	115	130	M8	1.0
65 59 305	95.0	72	202	5	47	105	115	M8	1.0
65 59 306	60.0	74	204	7	49	100	75, 90, 115	M5,M5,M8	1.0
65 59 307	70.0	70	200	7	45	100	90, 115	M6,M8	1.0
65 59 401	95.0	73	203	7	48	100	115	M8	1.0
65 59 402	110.0	78	208	7	53	115	130	M8	1.0
65 59 403	95.0	73	203	7	48	115	130	M8	1.0
65 59 404	110.0	73	203	7	48	115	130	M8	1.0
65 59 405	95.0	78	208	7	53	140	165	M10	1.0
65 59 406	110.0	78	208	7	53	140	165	M10	1.0
65 59 407	130.0	78	208	7	53	140	165	M10	1.0
65 59 409	130.0	98	228	7	73	140	165	M10	1.5
65 59 410	110.0	74	204	7	49	120	145	M8	1.0
65 59 411	110.0	84	214	7	59	120	145	M8	1.5
65 59 412	114.3	105	235	7	80	180	200	M12	3.5
65 59 413	114.3	139	269	7	114	180	200	M12	6.0
65 59 414	114.3	91	221	7	66	180	200	M12	2.5
65 59 415	110.0	89	219	7	64	120	145	M8	1.5

The order should contain gear box 51 24 0xx / 51 34 0xx and flange 65 59 3xx or 4xx.



Size BG 80

Fig. 1 Output shaft with key connection

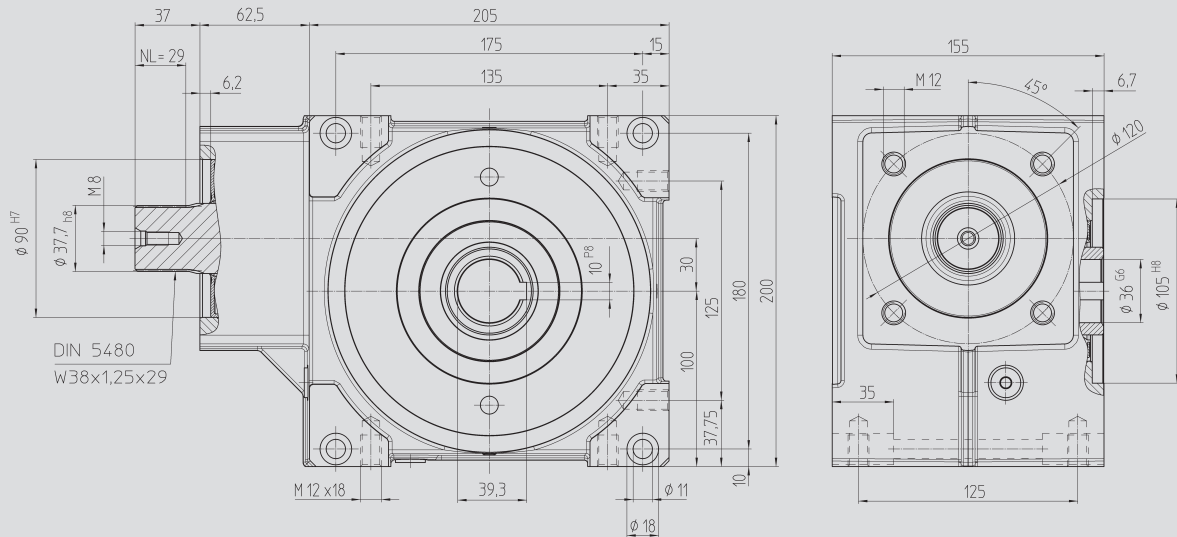

Size BG 80

Fig. 2 Output shaft for clamp connection 80 85 050

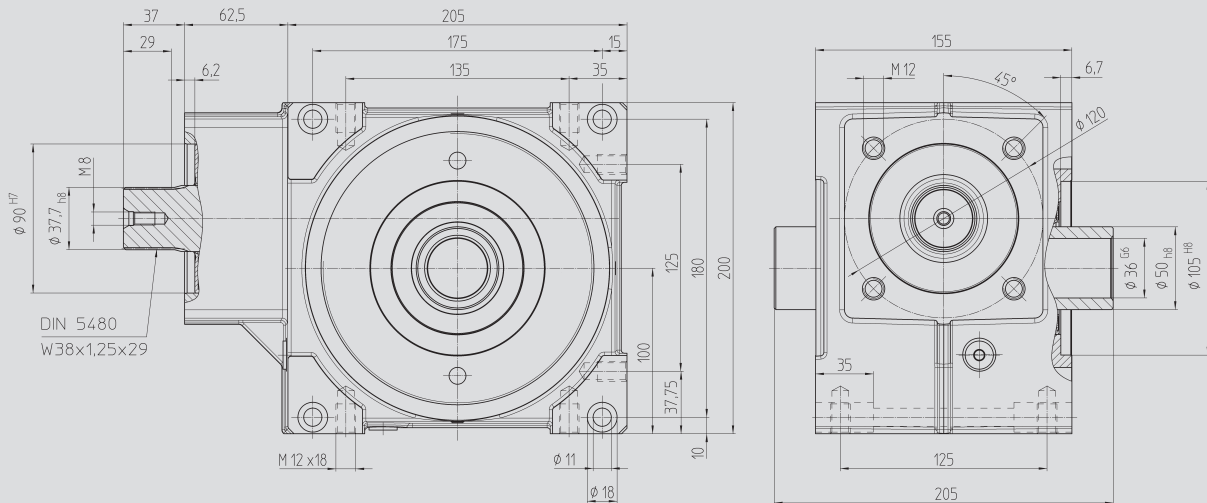

Order Code

Fig. 1

Fig. 2

Ratio i



**J_{red} 10⁻⁴
kg m²**

51 25 005	51 35 005	4.75	23.0	7.800
51 25 007	51 35 007	6.75	23.0	4.620
51 25 009	51 35 009	9.25	23.0	3.270

With food grade oil, order code 51 25 1xx / 51 35 1xx. With ATEX version with food grade oil, order code 51 25 2xx / 51 35 2xx.



Motor Flange

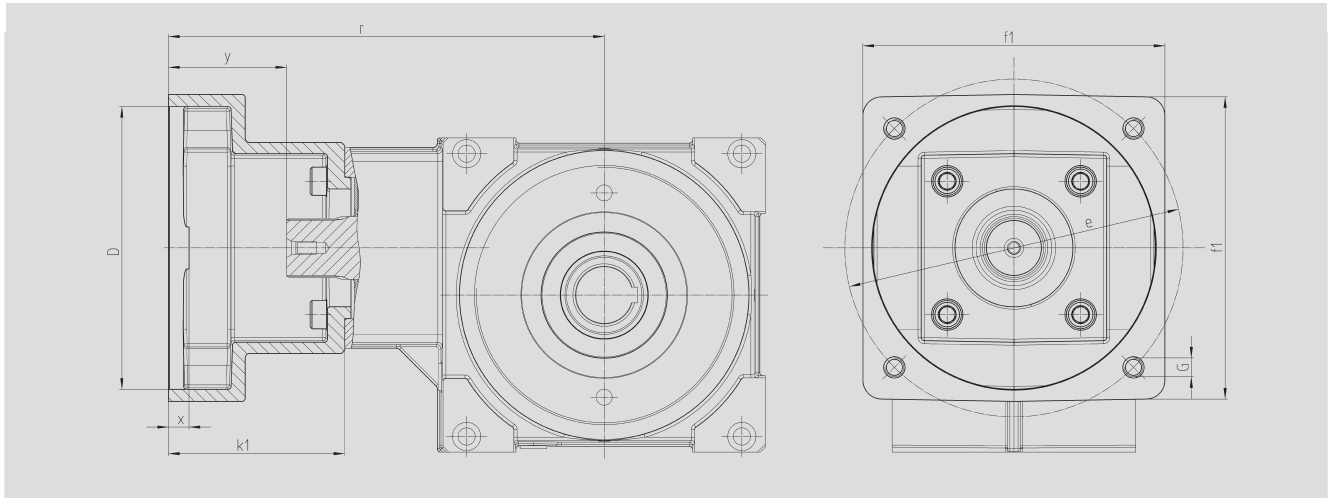

Size 80 mm

Order Code	D ^{G7}	k ₁	r	x	y	f ₁	e	G	kg
65 59 501	110.0	92.0	257.0	8.0	55.0	140	165	M10	2.0
65 59 502	130.0	92.0	257.0	8.0	55.0	140	165	M10	3.0
65 59 503	180.0	122.0	287.0	8.0	85.0	192	215	M12	3.5
65 59 504	180.0	127.0	292.0	8.0	90.0	192	215	M12	3.5
65 59 505	180.0	112.0	277.0	10.0	75.0	192	215	M12	3.0
65 59 506	130.0	112.0	277.0	10.0	75.0	192	215	M12	3.0
65 59 507	130.0	112.0	277.0	10.0	75.0	140	165	M10	4.5
65 59 508	110.0	90.0	255.0	8.0	53.0	140	145	M8	2.0
65 59 509	110.0	108.5	273.5	8.0	71.5	140	145	M8	2.5
65 59 510	114.3	129.5	294.5	8.0	92.5	180	200	M12	5.5
65 59 511	114.3	163.5	328.5	8.0	126.5	180	200	M12	8.0
65 59 512	114.3	105.5	270.5	8.0	68.5	180	200	M12	4.0
65 59 513	110.0	113.5	278.5	8.0	76.5	140	145	M8	2.5

The order should contain gear box 51 25 0xx / 51 35 0xx and flange 65 59 5xx.



Special Couplings for Motor/Gear Units, rigid model, nitrided, preassembled for motor shafts without key

Bore on gear unit side
low-clearance tooth-hub
profile corresponding to
DIN 5480 for push-fitting

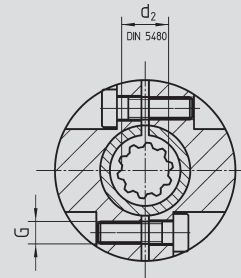
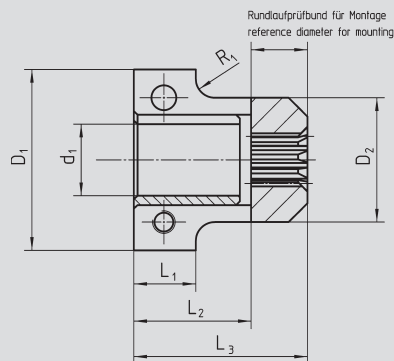

Order Code

Coupling	d ₁	d ₂	D ₁	D ₂	L ₁	L ₃	R ₁	G	L ₂	J _{red} 10 ⁻⁴ kg m ²	kg
65 51 008	8	15x1.25x10	36	23	14.0	46.0	5	M5	31.2	0.236	0.2
65 51 009	9	15x1.25x10	36	23	14.0	46.0	5	M5	31.2	0.246	0.2
65 51 010	10	15x1.25x10	36	23	14.0	46.0	5	M5	31.2	0.244	0.2
65 51 011	11	15x1.25x10	36	23	14.0	46.0	5	M5	31.2	0.243	0.2
65 51 014	14	15x1.25x10	36	23	14.0	46.0	5	M5	31.2	0.234	0.2
65 51 016	16	15x1.25x10	36	23	14.0	46.0	5	M5	31.2	0.225	0.2
65 53 019	19	15x1.25x10	48	33	16.5	46.0	5	M6	31.2	0.704	0.3
65 53 020	20	15x1.25x10	48	33	16.5	46.0	5	M6	31.2	0.704	0.3
65 53 022	22	15x1.25x10	48	33	16.5	46.0	5	M6	31.2	0.704	0.3
65 53 024	24	15x1.25x10	48	33	16.5	46.0	5	M6	31.2	0.647	0.2
65 53 025	25	15x1.25x10	64	51	18.0	55.5	5	M8	41.5	5.946	1.1
65 53 028	28	15x1.25x10	64	51	18.0	55.5	5	M8	41.5	5.871	1.1
65 53 032	32	15x1.25x10	64	51	18.0	55.5	5	M8	41.5	4.158	0.8
65 53 035	35	15x1.25x10	78	51	18.0	55.5	5	M8	41.5	5.605	1.0
65 53 038	38	15x1.25x10	78	51	18.0	55.5	5	M8	41.5	5.432	0.9
65 54 009	9	25x1.25x18	49	35	17.0	68.0	5	M6	43.5	2.306	0.5
65 54 010	10	25x1.25x18	49	35	17.0	68.0	5	M6	43.5	2.300	0.5
65 54 011	11	25x1.25x18	49	35	17.0	68.0	5	M6	43.5	2.381	0.5
65 54 014	14	25x1.25x18	49	35	17.0	68.0	5	M6	43.5	1.161	0.5
65 54 015	15	25x1.25x18	49	35	17.0	68.0	5	M6	43.5	2.328	0.5
65 54 016	16	25x1.25x18	49	35	17.0	68.0	5	M6	43.5	1.161	0.5
65 54 019	19	25x1.25x18	49	35	17.0	68.0	5	M6	43.5	1.112	0.4
65 54 020	20	25x1.25x18	49	35	17.0	68.0	5	M6	43.5	2.268	0.5
65 54 022	22	25x1.25x18	49	35	17.0	68.0	5	M6	43.5	2.179	0.4
65 54 024	24	25x1.25x18	49	35	17.0	68.0	5	M6	43.5	1.007	0.4
65 54 025	25	25x1.25x18	64	51	18.0	68.0	5	M8	43.5	8.165	1.2
65 54 028	28	25x1.25x18	64	51	18.0	68.0	5	M8	43.5	8.061	1.2
65 54 032	32	25x1.25x18	64	51	18.0	68.0	5	M8	43.5	7.751	1.2
65 54 035	35	25x1.25x18	78	51	18.0	68.0	5	M8	43.5	7.690	1.1
65 54 038	38	25x1.25x18	78	51	18.0	68.0	5	M8	43.5	7.348	1.1
65 54 042	42	25x1.25x18	78	51	18.0	65.5	5	M8	43.5	6.595	1.1
65 55 014	14	38x1.25x29	64	51	18.0	72.5	5	M8	41.5	8.056	1.2
65 55 016	16	38x1.25x29	64	51	18.0	72.5	5	M8	41.5	8.029	1.2
65 55 019	19	38x1.25x29	64	51	18.0	72.5	5	M8	41.5	7.978	1.2
65 55 020	20	38x1.25x29	64	51	18.0	72.5	5	M8	41.5	7.945	1.2
65 55 022	22	38x1.25x29	64	51	18.0	72.5	5	M8	41.5	7.911	1.2
65 55 024	24	38x1.25x29	64	51	18.0	72.5	5	M8	41.5	7.860	1.2
65 55 025	25	38x1.25x29	64	51	18.0	72.5	5	M8	41.5	7.818	1.1
65 55 028	28	38x1.25x29	64	51	18.0	72.5	5	M8	41.5	8.105	1.3
65 55 032	32	38x1.25x29	64	51	18.0	72.5	5	M8	41.5	7.863	1.2
65 55 035	35	38x1.25x29	78	51	18.0	72.5	5	M8	41.5	7.610	1.1
65 55 038	38	38x1.25x29	78	51	18.0	72.5	5	M8	41.5	7.284	1.0
65 55 042	42	38x1.25x29	78	51	18.0	70.5	5	M8	41.5	6.547	1.0

Couplings on page GA-10 can be used as well.



Shrink-Disk Clamping Sets for Output Drive Shafts of gear series 51 3. ...

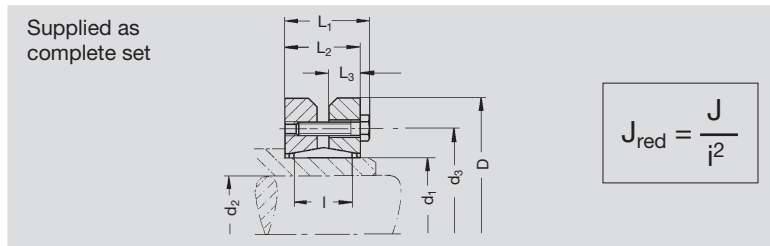

Order Code	BG	Nm	d ₁	d ₂	d ₃	D	L ₁	L ₂	L ₃	l	G	J 10 ⁻⁴ kg m ²	kg
80 83 030	50	400	30	25	44	60	25.0	21.50	9	16	7 x M5	1.756	0.3
80 84 036	63	540	36	28	52	72	27.5	23.50	10	18	5 x M6	4.029	0.4
80 85 050	80	1180	50	36	70	90	31.5	27.50	12	22.5	9 x M6	11.322	0.8





The values in the tables are based upon wear or maximum flank load at 12,000 hours full load and on servo-operation. With continuous full-load operation it may be necessary to consider temperature limits! (Please ask us, if in doubt.)

T_{2max} = static torque to avoid tooth fracture, P_1 = driving power in kW, T_2 = output torque in Nm.

BG Bevel-Gear Units



Order Code	BG	i	T_{2max}	Input Speed n_1 (rpm)												η at 1500		
				500		750		1000		1500		3000		4000			5000	
				P_1 (kw)	T_2 (Nm)	P_1 (kw)	T_2 (Nm)	P_1 (kw)	T_2 (Nm)	P_1 (kw)	T_2 (Nm)	P_1 (kw)	T_2 (Nm)	P_1 (kw)	T_2 (Nm)		P_1 (kw)	T_2 (Nm)
51 23 _05 51 33 _05	50	4.75	145	1.14	97	1.71	97	2.28	97	3.41	97	6.82	97	9.10	97	11.37	97	0.94
51 23 _07 51 33 _07		6.75	125	0.57	68	0.86	68	1.15	68	1.72	68	3.44	68	4.59	68	5.73	68	0.92
51 23 _09 51 33 _09		9.25	100	0.35	56	0.53	56	0.70	56	1.06	56	2.11	56	2.82	56	3.52	56	0.90
51 24 _05 51 34 _05	63	4.75	305	2.34	200	3.52	200	4.69	200	7.04	200	14.07	200	18.76	200	23.45	200	0.94
51 24 _07 51 34 _07		6.75	280	1.22	145	1.83	145	2.45	145	3.67	145	7.33	145	9.78	145	12.22	145	0.92
51 24 _09 51 34 _09		9.25	245	0.81	128	1.21	128	1.61	128	2.42	128	4.83	128	6.44	128	8.05	128	0.90
51 25 _05 51 35 _05	80	4.75	750	5.86	500	8.79	500	11.73	500	17.59	500	35.18	500	46.90	500	58.63	500	0.94
51 25 _07 51 35 _07		6.75	660	2.99	355	4.49	355	5.99	355	8.98	355	17.96	355	23.94	355	29.93	355	0.92
51 25 _09 51 35 _09		9.25	510	1.73	275	2.59	275	3.46	275	5.19	275	10.38	275	13.84	275	17.29	275	0.90

Additional loads on output drive

The data given are reference values. You should consider the values arising from the choice of the tooth system. It is assumed that the point of action of the force is the center of the shaft. In cases where additional axial forces occur, over and above high transverse forces, please ask for advice.

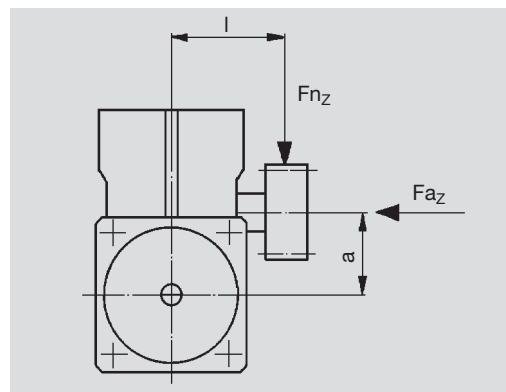

Size	BG	50		63		80	
Dimension center of casing to center of pinion l (mm)		90	140	110	160	125	175
Max. additional load							
radial F_{rZ}	[N]	4000	2570	6000	4120	7500	5360
axial F_{aZ}	[N]	1800	1800	2800	2800	3500	3500



Short Description

ATLANTA BG servo bevel-gear units have been specially developed for use with new generation three-phase AC motors and DC motors. Like all other items in this catalog they are usually available from stock or within very short time.

Our servo bevel-gear units feature:

- gear ratios which are similar, sometimes identical with those of the series 98, 58, and 59
- low-clearance gearing (backlash < 6")
- light-alloy housing for optimal heat dissipation
- robust tapered-roller bearing of the output hollow shaft for high additional forces
- low moments of inertia for high dynamics

Sizes and gear ratios correspond with those of the existing servo worm-gear unit series. The bevel-gears are manufactured and installed with optimal tooth bearing. The use of bevel-gears end-lapped in sets guarantees smooth running in both directions of rotation. The housing is machined on all sides and provided with many fixing holes and threaded bores and can thus be installed in any mounting position desired.



The drive or the connection to the driving motor, is realized via a special clutch. The internal gearing of this clutch in combination with the barrelled profile of the driving shaft of our bevel-gear units assures the flow of forces without play.

For the output drive we offer quite a number of output shafts with straight or helical tooth systems and with different numbers of teeth. Besides pinion shafts it is possible to combine and use a large variety of other numbers of teeth from our gear-wheel program with matching special output shafts. It goes without saying that analogous to our gear units the complete range of output shafts is not only available for key fitting but also for shrink-disk fitting.

Our wide range of standard elements for servo drives is supplemented by racks. The ex-stock program comprises many different types from rather simple, soft racks through hardened versions with straight tooth system or optionally with helical tooth system for smooth running, to racks ground on all sides to very narrow tolerances.

For emergency stops, the maximum transmittable torque of the gear unit (see page GE-10) and shrink disk (see page GH-1) has to be checked. The output keyway has to be calculated separately.



Mounting Instructions

Bevel-Gear Unit

Five machined mounting surfaces with sufficiently dimensioned fixing holes and threaded bores are provided for tension-free installation in any mounting position. In order to make full use of the additional dynamic forces (see p. GE-10) we recommend to choose the largest available contact surfaces, i.e. on the side of the cover or on the opposite side. Lubrication conditions are almost the same in all mounting positions.

Coupling

The coupling is supplied pre-assembled. Before fixing it on the motor shaft carefully clean all contact surfaces and protect them with a thin oil film. An important dimension for mounting is "X1" (compare pages GI – 5 to GI – 9)

We recommend to proceed as follows:

- Clean the contact surfaces and protect them with a thin oil film.
- Position the coupling on the motor shaft at the distance "X1" (see pages GI – 5 to GI – 9) using a depth gauge for determining this dimension.
- Slightly tighten the screws alternately and check the coupling for true running
- Observe the tightening torque indicated in the operation and maintenance instructions bearing in mind that the width of the gap on both sides of the clutch must remain the same.
- It is advisable to make another final concentricity check at the reference collar.

A mounting guide can be found on page GI-5 to GI-9

Motor

Insert the motor with coupling mounted into the gear centering piece and bolt it to the gearbox.

Output Pinion Shaft

Unless the output pinion shaft comes already fully assembled, we recommend to proceed as follows:
Clean pinion shaft and hollow shaft extension and then oil them. For the special output drive shaft we recommend tolerance h6 (DIN ISO286). the material must have a minimum yield point of 385 N/mm². A recalculation of the strength is necessary.

Output Drive Shaft for Shrink-Disk Connection

Slide shrink disk onto the hollow shaft extension of the gear unit (please do not tighten the screws beforehand!). Insert the output shaft from the desired side into the hollow shaft fully up to the stop. Make the transverse pressure connection by evenly tightening the clamping screws. Tighten the screws one after the other (not crosswise) in several passes to the torque indicated in the operation and maintenance instructions.





Output Drive Shaft for Key Connection

The retaining ring, the disc and the screw supplied with the output drive shaft serve for locking the output shaft in axial direction. For this purpose insert the retaining ring in the applicable recess of the hollow shaft and slide the output drive shaft from the desired side into the hollow shaft up to the stop. Disc and screw are screwed to the output shaft from the other side of the gear unit. The retaining ring must be clamped between disc and pinion shaft.

Maintenance

Lubricant Change

ATLANTA servo bevel-gear units are filled with synthetic polyglycol oil.

Under the following conditions this means lifetime lubrication:

The layout of the gear unit is made strictly in conformance with the guidelines specified in the ATLANTA catalogue and the gear unit is operated exclusively within the permissible characteristic values and limits. The operator checks the gear regularly (every 4 weeks) for oil leakage. The surface temperature does not exceed max. 80° C. Experience has shown that this temperature is not reached with servo-operation (intermittent operation).

Size	Oil Quantity
BG 50	0.3 l
BG 63	0.5 l
BG 80	1.2 l

We recommend the following synthetic gear lubricant:

Klübersynth GH 6 - 220

Order Code: 65 90 010 (1 liter)

Alternative:

SHELL Tivela S 220, BP Enersyn SG-XP 220, ARAL Degol GS 220

Degree to Protection

Degree of protection: IP65/67 according to ISO 20653
(Corrosion has to be verified separately).





	Page
Calculation and Selection	GF2 – GF3
Gear Unit Accessories	GG1 – GG8
Mounting Guide for HT and HP Servo Gears	GI1 – GI4
Mounting Guide for E, B and BG Servo Gears	GI5 – GI9





The values given in the load table are based on uniform, smooth servo-operation. Since, in practice, the applications are very diverse, it is essential to consider the given conditions by using the appropriate factors S , K_A and b_B (see symbols). The maximum oil-sump temperature of 80° C should not be exceeded.

Formulas for Determining Power and Torque Data:

$$a = \frac{v}{t_b} \quad [\text{m/s}^2]$$

$$F_u = m \cdot g + m \cdot a \quad (\text{for lifting axle}) \quad [\text{N}]$$

$$F_u = m \cdot g \cdot \mu + m \cdot a \quad (\text{for driving axle}) \quad [\text{N}]$$

$$T_{2req.} = \frac{F_u \cdot d}{2000} \quad [\text{Nm}]$$

$$n_2 = \frac{v}{d \cdot \pi} \cdot 60000 \quad (\text{rpm}) \quad [\text{rpm}]$$

$$i_{gear} = \frac{n_1}{n_2}$$

$$T_{2perm.} = \frac{T_{2table}}{K_A \cdot S \cdot b_B} \quad [\text{Nm}]$$

Condition $T_{2perm.} > T_{2req.}$ must be fulfilled.

$$P_{1req.} = \frac{T_{2req.} \cdot n_2}{9550 \cdot \eta} \quad [\text{kW}]$$

Load Factor K_A

Drive	Type of load from the machines to be driven		
	uniform	medium shocks	heavy shocks
uniform	1.00	1.25	1.75
light shocks	1.25	1.50	2.00
medium shocks	1.50	1.75	2.25

Operating Time Factor b_B

Operating time	4-8 h	8-12 h	>12 h
Operating time factor	1.00	1.20	1.35

Safety Coefficient S

The Safety Coefficient should be allowed for according to experience ($S = 1.1$ to 1.4).

Symbols

a	= Acceleration or Retardation	(m/s ²)
b_B	= Operating Time Factor	
d	= Pinion Pitch-Circle Diameter	(mm)
g	= Acceleration Due to Gravity	(9.81m/s ²)
m	= Mass	(kg)
n_1	= Gearbox Input rpm	(rpm)
n_2	= Gearbox Output rpm	(rpm)
t_b	= Acceleration Time	(s)
i	= Gear Ratios	(--)
v	= Travelling/Lifting Speed	(m/s)
F_u	= Peripheral Force at the Pinion	(N)
K_A	= Load Factor	(--)
P_1	= Gearbox Input Power	(kW)
S	= Safety Coefficient	(--)
T_2	= Gearbox Output Torque	(Nm)
η	= Gearbox Efficiency	(--)
μ	= Coefficient of Friction	(--)
π	= 3.1459	



Calculating Example

Values Given

Travelling Operation Lifting Operation
 Mass to be Moved $m = 300$ kg
 Speed $v = 1.08$ m/s
 Acceleration Time $t_b = 0.27$ s
 Acceleration Due to Gravity $g = 9.81$ m/s²
 Coefficient of Friction $\mu = \text{---}$
 Pitch-Circle Dia. of Pinion $d = 63.66$ mm
 Load Factor $K_A = 1.25$
 Operation Time Factor $b_B = 1.2$
 Safety Coefficient $S = 1.2$
 Motor rpm $n_1 = 3000$ rpm
 Motor Type _____
 Motor Manufacturer _____

Calculation Process

$$a = \frac{v}{t_b} \quad a = \frac{1.08}{0.27} = 4 \text{ m/s}^2$$

$$F_u = m \cdot g + m \cdot a \quad F_u = 300 \cdot 9.81 + 300 \cdot 4 = 4,143 \text{ N}$$

only Travelling Operation

$$F_u = m \cdot g + \mu + m \cdot a$$

$$T_{2\text{erf.}} = \frac{F_u \cdot d}{2000} \quad T_{2\text{erf.}} = \frac{4143 \cdot 63.66}{2000} = 132 \text{ Nm}$$

$$n_2 = \frac{v}{d \cdot \pi} \cdot 60,000 \quad n_2 = \frac{1.08}{63.66 \cdot \pi} \cdot 60000 = 324 \text{ rpm}$$

$$i_{\text{Getr.}} = \frac{n_1}{n_2} \quad i_{\text{Getr.}} = \frac{3000}{325} \cong 9.25$$

Permissible Gear Torque $T_{2\text{table}}$ see page GB-13
 assumed 58_5_09 with $T_2=280$ Nm at 3,000 rpm

$$T_{2\text{zul.}} = \frac{T_{2\text{Table}}}{K_A \cdot S \cdot b_B} \quad T_{2\text{zul.}} = \frac{280}{1.25 \cdot 1.2 \cdot 1.2} = 155 \text{ Nm}$$

Condition

$$T_{2\text{zul.}} > T_{2\text{erf}} = 155 \text{ Nm} > 132 \text{ Nm} \quad = \text{fulfilled}$$

$$P_{1\text{erf}} = \frac{T_{2\text{erf}} \cdot n_2}{9550 \cdot \eta} \quad P_{1\text{erf}} = \frac{132 \cdot 324}{9550 \cdot 0.90} = 4.98 \text{ KW}$$

Your Calculation

Values Given

Travelling Operation Lifting Operation
 Mass to be Moved $m = \text{---}$ kg
 Speed $v = \text{---}$ m/s
 Acceleration Time $t_b = \text{---}$ s
 Acceleration Due to Gravity $g = \underline{9.81}$ m/s²
 Coefficient of Friction $\mu = \text{---}$
 Pitch-Circle Dia. of Pinion $d = \text{---}$ mm
 Load Factor $K_A = \text{---}$
 Operation Time Factor $b_B = \text{---}$
 Safety Coefficient $S = \text{---}$
 Motor rpm $n_1 = \text{---}$ rpm
 Motor Type _____
 Motor Manufacturer _____

Calculation Process

$$a = \frac{v}{t_b} \quad a = \text{---} = \text{---} \text{ m/s}^2$$

$$F_u = m \cdot g + m \cdot a \quad F_u = \text{---} = \text{---} \text{ N}$$

$$F_u = m \cdot g + \mu + m \cdot a \quad F_u = \text{---} = \text{---} \text{ N}$$

$$T_{2\text{erf.}} = \frac{F_u \cdot d}{2000} \quad T_{2\text{erf.}} = \text{---} = \text{---} \text{ Nm}$$

$$n_2 = \frac{v}{d \cdot \pi} \cdot 60000 \quad n_2 = \text{---} \cdot 60000 = \text{---} \text{ rpm}$$

$$i_{\text{Getr.}} = \frac{n_1}{n_2} \quad i_{\text{Getr.}} = \text{---} \cong \text{---}$$

Permissible Gear Torque $T_{2\text{table}}$ see page ...

$$T_{2\text{zul.}} = \frac{T_{2\text{Table}}}{K_A \cdot S \cdot b_B} \quad T_{2\text{zul.}} = \text{---} = \text{---} \text{ Nm}$$

Condition

$$T_{2\text{zul.}} > T_{2\text{erf}} = \text{---} \text{ Nm} > \text{---} \text{ Nm} = \text{fulfilled}$$

$$P_{1\text{erf}} = \frac{T_{2\text{erf}} \cdot n_2}{9550 \cdot \eta} \quad P_{1\text{erf}} = \text{---} = \text{---} \text{ KW}$$





	Page
Pinion and Output Drive Shafts for High-Performance Gear Units	GG2 – GG4
Pre-Load Pinion Shafts	GG5 – GG7
Adjusting Wrench	GG8
Shrink-Disk Clamping Sets	GH1
Lubrication Units	ZE5 – ZE6





Straight Tooth System, 20° Pressure Angle, teeth are ground and crowned, Tolerances acc. to DIN 3962/63/67

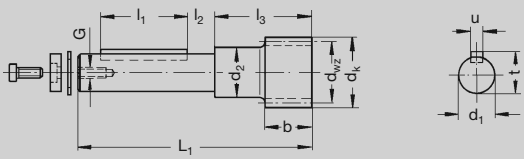

16MnCr5, 1.7131
Case-Hardened
Tooth. Qual. 6 e 25

Order Code	Gearbox ao HP/E/B	Module	No. of Teeth	x	d _{wz}	d _k	b	d _{1h6}	d ₂	L ₁	l ₁	l ₂	l ₃	u	t	G	a	kg
20 28 115	32	2	15	0.375	31.50	35.5	25	20	24	105	28	13.5	50.0	6	22.5	M 5	37.75	0.50
20 28 021	50	2	21	-	42.00	46.0	25	25	35	141	63	13.0	53.0	8	28.0	M 8	43.00	1.21
20 28 332	50	2	32	-	64.00	68.0	25	25	38	141	63	13.0	53.0	8	28.0	M 8	54.00	1.25
20 28 321	50	3	21	-	63.00	69.0	30	25	38	143	63	13.0	55.0	8	28.0	M 8	57.50	1.33
20 28 432	63	2	32	-	64.00	68.0	25	28	42	166	80	14.5	57.5	8	31.0	M 8	54.00	1.50
20 28 421	63	3	21	-	63.00	69.0	30	28	42	168	80	14.5	60.0	8	31.0	M 8	57.50	1.60
20 28 417	63	4	17	-	68.00	76.0	40	28	42	173	80	14.5	65.0	8	31.0	M 8	69.00	2.00
20 28 532	80	2	32	-	64.00	68.0	25	36	48	181	100	12.5	57.0	10	39.0	M12	54.00	2.35
20 28 521	80	3	21	-	63.00	69.0	30	36	48	186	100	12.5	62.0	10	39.0	M12	57.50	2.50
20 28 517	80	4	17	-	68.00	76.0	40	36	48	191	100	12.5	67.0	10	39.0	M12	69.00	2.65
20 28 617	100	4	17	-	68.00	76.0	40	48	57	216	125	9.0	72.0	14	51.5	M12	69.00	4.05
20 28 630	100	4	30	-	120.00	128.0	40	48	57	216	125	9.0	72.0	14	51.5	M12	95.00	6.40
20 28 613	100	5	13	0.500	70.00	80.0	50	48	57	226	125	9.0	82.0	14	51.5	M12	69.00	4.20
20 28 715	125	5	15	0.500	80.00	90.0	50	60	68	272	150	10.0	90.0	18	64.0	M16	74.00	6.94
20 28 713	125	6	13	0.500	84.00	96.0	60	60	68	282	150	10.0	100.0	18	64.0	M16	85.00	7.45

Helical Tooth System, 19°31'42" left, 20° Pressure Angle, teeth are ground and crowned, Tolerances acc. to DIN 3962/63/67

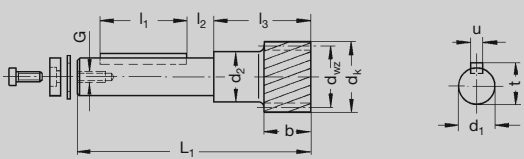

16MnCr5, 1.7131
Case-Hardened
Tooth. Qual. 6 e 25

Order Code	Gearbox ao HP/E/B	Module	No. of Teeth	x	d _{wz}	d _k	b	d _{1h6}	d ₂	L ₁	l ₁	l ₂	l ₃	u	t	G	a	kg
20 29 120	32	1.5	20	-	31.83	34.83	20	20	26	100	40	7.5	45.0	6	22.5	M 5	33.42	0.60
20 29 115	32	2	15	0.4172	33.50	37.50	25	20	24	105	28	13.5	50.0	6	22.5	M 5	39.75	0.50
20 29 020	50	2	20	-	42.44	46.44	25	25	35	141	63	13.0	53.0	8	28.0	M 8	43.22	1.21
20 29 330	50	2	30	-	63.66	67.70	25	25	38	141	63	13.0	53.0	8	28.0	M 8	53.83	1.25
20 29 320	50	3	20	-	63.66	69.70	30	25	38	143	63	13.0	55.0	8	28.0	M 8	57.83	1.33
20 29 430	63	2	30	-	63.66	67.70	25	28	42	166	80	14.5	57.5	8	31.0	M 8	53.83	1.50
20 29 420	63	3	20	-	63.66	69.70	30	28	42	168	80	14.5	60.0	8	31.0	M 8	57.83	1.60
20 29 415	63	4	15	-	63.66	71.70	40	28	42	173	80	14.5	65.0	8	31.0	M 8	66.83	1.85
20 29 530	80	2	30	-	63.66	69.70	25	36	48	181	100	12.5	57.0	10	39.0	M12	53.83	2.40
20 29 520	80	3	20	-	63.66	69.70	30	36	48	186	100	12.5	62.0	10	39.0	M12	57.83	2.40
20 29 515	80	4	15	-	63.66	71.70	40	36	48	191	100	12.5	67.0	10	39.0	M12	66.83	2.50
20 29 615	100	4	15	-	63.66	71.70	40	48	57	216	125	9.0	72.0	14	51.5	M12	66.83	3.90
20 29 630	100	4	30	-	127.32	135.30	40	48	57	216	125	9.0	72.0	14	51.5	M12	98.66	6.90
20 29 612	100	5	12	0.434	68.00	78.00	50	48	57	226	125	9.0	82.0	14	51.5	M12	68.00	4.20
20 29 715	125	5	15	0.500	84.58	94.50	50	60	68	272	150	10.0	90.0	18	64.0	M16	76.29	7.24
20 29 713	125	6	13	0.500	88.76	100.70	60	60	70	282	150	10.0	100.0	18	64.0	M16	87.38	7.89

Calculation of center distance a between pinion and rack.

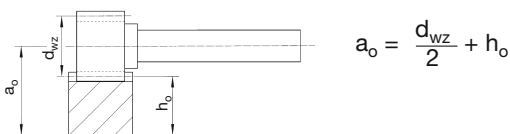



Output Drive Shafts for Key Connection

without Teeth, of 16 MnCr 5, Mat. No.1.7131

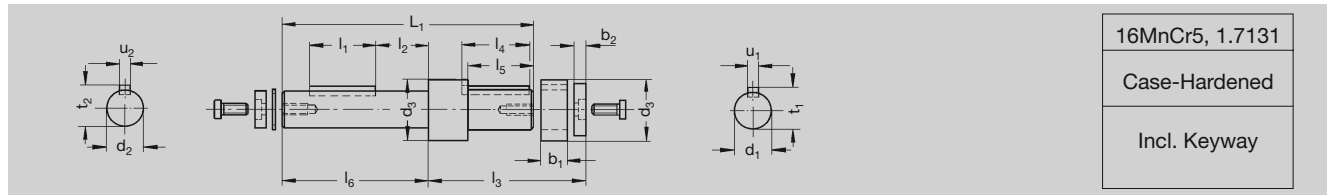

Order Code	Gearbox ao HP/E/B	d _{1h6}	d _{2j6}	d ₃	L ₁	l ₁	l ₂	l ₃	l ₄	l ₅	l ₆	u ₁	u ₂	t ₁	t ₂	b ₁	b ₂	kg
65 02 001	32	20	20	-	119.0	40	-	dep. on pairing	40	-	-	6	6	22.5	22.5	-	-	0.6
65 03 040	50	25	25	40	160.0	63	13.0		50	48	87	8	8	28.0	28.0	20	8.0	0.9
65 03 140	50	25	25	40	210.0	63	13.0		50	48	87	8	8	28.0	28.0	20	8.0	1.3
65 04 040	63	28	30	45	185.0	80	14.5		50	48	107	8	8	31.0	33.0	20	8.0	1.1
65 04 140	63	28	30	45	235.0	80	14.5		50	48	107	8	8	31.0	33.0	20	8.0	1.7
65 05 040	80	36	35	48	203.5	100	12.5		50	48	123	10	10	39.0	38.0	20	11.5	2.0
65 05 140	80	36	35	48	253.5	100	12.5		50	48	123	10	10	39.0	38.0	20	11.5	2.7
65 06 040	100	48	45	60	248.5	125	9.0		70	68	143	14	14	51.5	48.5	40	11.5	4.0
65 06 140	100	48	45	60	298.5	125	9.0		70	68	143	14	14	51.5	48.5	40	11.5	5.0
65 07 040	125	60	55	74	316.0	150	10.0		100	99	182	16	18	59.0	64.0	20	16.0	8.6

In the case of hardened gears and shrink-disk mounting of the gears we recommend to recalculate the shaft strength.

Output Drive for Shrink-Disk Connection

without Teeth, of 16 MnCr 5, Mat.No.1.7131

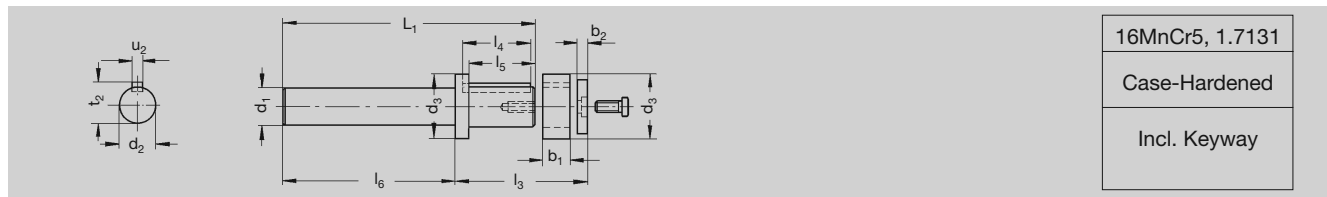

Order Code	Gearbox ao HT/BG HP/E/B	d _{1h6}	d _{2j6}	d ₃	L ₁	l ₃	l ₄	l ₅	l ₆	u ₂	t ₂	b ₁	b ₂	kg
65 03 080	50	25	25	40	168	dep. on pairing	50	48	113.5	8	28	20	8	0.8
65 03 180	50	25	25	40	218		50	48	113.5	8	28	20	8	1.2
65 04 080	50	63	28	30	45	200	50	48	141	8	33	20	8	1.0
65 04 180	50	63	28	30	45	250	50	48	141	8	33	20	8	1.6
65 05 080	63	80	36	35	48	226	50	48	170.5	10	38	20	11.5	1.8
65 05 180	63	80	36	35	48	276	50	48	170.5	10	38	20	11.5	2.5
65 06 080	80	100	48	45	60	273	70	68	196.5	14	48.5	40	11.5	3.8
65 06 180	80	100	48	45	60	323	70	68	196.5	14	48.5	40	11.5	4.8
65 07 080	100	125	60	55	74	329	100	99	220	16	64	20	16	8.0

In the case of hardened gears and shrink-disk mounting of the gears we recommend to recalculate the shaft strength.





Straight Tooth System, 20° Pressure Angle, teeth are ground and crowned, Tolerances acc. to DIN 3962/63/67

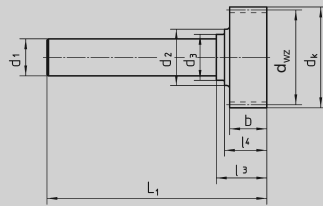

16MnCr5, 1.7131
Case-Hardened
Tooth. Qual. 6 e 25

Order Code	Gearbox Size HT/BG HP/E/B	Module	No. of Teeth	x	d_{wz}	d_k	b	d_{1h6}	d_2	d_3	L_1	l_3	l_4	a	kg	
20 88 115	32	2	15	0.375	31.50	35.5	25	20	24	-	105	31.0	-	37.75	0.50	
20 88 021	50	2	21	-	42.00	46.0	25	25	35	31	148	34.0	28.5	43.00	1.21	
20 88 332	50	2	32	-	64.00	68.0	25	25	38	31	148	34.0	28.5	54.00	1.25	
20 88 321	50	3	21	-	63.00	69.0	30	25	31	-	150	36.5	-	57.50	1.33	
20 88 432	50	63	2	32	-	64.00	68.0	25	28	42	36	180	38.5	33.0	54.00	1.50
20 88 421	50	63	3	21	-	63.00	69.0	30	28	42	36	183	41.0	35.5	57.50	1.60
20 88 417	50	63	4	17	-	68.00	76.0	40	28	36	-	188	46.0	-	69.00	2.00
20 88 532	63	80	2	32	-	64.00	68.0	25	36	48	-	203	32.5	-	54.00	2.35
20 88 521	63	80	3	21	-	63.00	69.0	30	36	48	-	208	37.5	-	57.50	2.50
20 88 517	63	80	4	17	-	68.00	76.0	40	36	48	-	213	42.5	-	69.00	2.65
20 88 617	80	100	4	17	-	68.00	76.0	40	48	57	-	240	43.5	-	69.00	4.05
20 88 630	80	100	4	30	-	120.00	128.0	40	48	57	-	240	43.5	-	95.00	6.40
20 88 613	80	100	5	13	0.500	70.00	80.0	50	48	57	-	250	53.5	-	69.00	4.10
20 88 715	100	125	5	15	0.500	80.00	90.0	50	60	68	-	275	55.0	-	74.00	6.30
20 88 713	100	125	6	13	0.500	84.00	96.0	60	60	68	-	285	65.0	-	85.00	6.84

Helical Tooth System, 19°31'42" left, 20° Pressure Angle, teeth are ground and crowned, Qual. 6 e 25 corresp. to DIN 3962/63/67

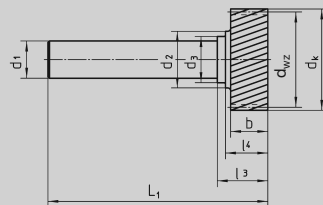

16MnCr5, 1.7131
Case-Hardened
Tooth. Qual. 6 e 25

Order Code	Gearbox Size HT/BG HP/E/B	Module	No. of Teeth	x	d_{wz}	d_k	b	d_{1h6}	d_2	d_3	L_1	l_3	l_4	a	kg	
20 89 120	32	1.5	20	-	31.83	34.83	20	20	26	-	100.25	26.0	-	33.40	0.50	
20 89 115	32	2	15	0.4172	33.50	37.50	25	20	24	-	105	31.0	-	38.75	0.50	
20 89 020	50	2	20	-	42.44	46.44	25	25	35	31	148	34.0	28.5	43.22	1.21	
20 89 330	50	2	30	-	63.66	67.70	25	25	38	31	148	34.0	28.5	53.83	1.25	
20 89 320	50	3	20	-	63.66	69.70	30	25	31	-	150	36.5	-	57.83	1.33	
20 89 430	50	63	2	30	-	63.66	67.70	25	28	42	36	180	38.5	33.0	53.83	1.60
20 89 420	50	63	3	20	-	63.66	69.70	30	28	42	36	183	41.0	35.5	57.83	1.60
20 89 415	50	63	4	15	-	63.66	71.70	40	28	36	-	188	46.0	-	66.83	1.85
20 89 530	63	80	2	30	-	63.66	69.70	25	36	48	-	203	32.5	-	53.83	2.35
20 89 520	63	80	3	20	-	63.66	69.70	30	36	48	-	208	37.5	-	57.83	2.40
20 89 515	63	80	4	15	-	63.66	71.70	40	36	48	-	213	42.5	-	66.83	2.50
20 89 615	80	100	4	15	-	63.66	71.70	40	48	57	-	240	43.5	-	66.83	3.90
20 89 630	80	100	4	30	-	127.32	135.30	40	48	57	-	240	43.5	-	98.66	6.90
20 89 612	80	100	5	12	0.434	68.00	78.00	50	48	57	-	250	53.5	-	68.00	4.10
20 89 613	80	100	6	13	0.500	86.76	100.76	60	48	57	-	260	63.5	-	87.38	4.30
20 89 715	100	125	5	15	0.500	84.58	94.50	50	60	70	-	275	55.0	-	76.29	6.57
20 89 713	100	125	6	13	0.500	88.76	100.70	60	60	70	-	285	65.0	-	87.38	7.13
20 48 713*	100	125	6	13	0.500	88.76	100.76	60	60	70	-	285	65.0	-	87.38	7.13
20 48 715*	100	125	6	15	0.500	101.49	113.49	60	60	70	-	285	65.0	-	73.75	7.60

* Gearing quality 4 e 22

Calculation of center distance a between pinion and rack.

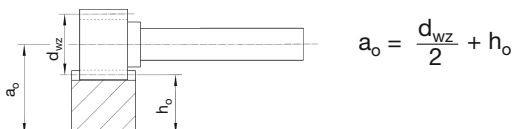



Helical Tooth System, 19°31'42" left hand, 20° Pressure Angle, Ground Teeth, Tolerance acc. to DIN 3962/63/67

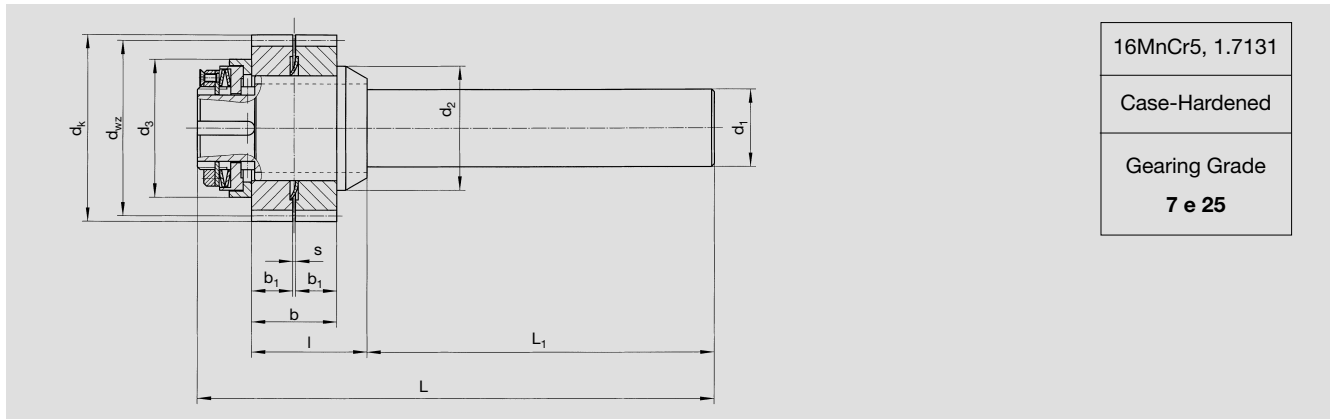

16MnCr5, 1.7131
Case-Hardened
Gearing Grade 7 e 25

Order Code	Module	Gearbox Size		Shrink-Disk	T ₂ (Nm)* without pre-load	T _{v max.} (Nm)* with max. pre-load	z	d _{wz} *	d _k	b	b ₁	d _{1h6}	d ₂	d ₃	s	l	L ₁	L	kg
74 92 330	2	50	80 83 030	135	67	30	63.66	67.7	31	15	25	45	50	1	37.5	114.0	171.5	1.41	
74 92 430	2	63	80 84 036	135	67	30	63.66	67.7	31	15	28	45	50	1	42.0	141.5	203.5	1.75	
74 93 320	3	50	80 83 030	250	125	20	63.66	69.7	31	15	25	45	50	1	37.5	114.0	171.5	1.45	
74 93 420	3	63	80 84 036	250	125	20	63.66	69.7	31	15	28	45	50	1	42.0	141.5	203.5	1.70	
74 93 520	3	80	80 85 050	250	125	20	63.66	69.7	31	15	36	48	50	1	41.0	170.5	237.5	2.45	
74 94 515	4	63	80 85 050	385	192	15	63.66	71.7	41	20	36	48	50	1	46.0	170.5	237.5	2.50	
74 95 615	5	80	80 86 062	650	325	15	84.58	94.5	52	25	48	57	70	2	57.0	196.5	284.5	5.50	
74 96 613	6	80	80 86 062	975	487	13	82.76	100.7	62	30	48	57	68	2	67.0	196.5	284.5	6.00	
74 96 713	6	100	80 87 080	975	487	13	82.76	100.7	62	30	60	72	68	2	67.0	220.0	308.0	9.00	
74 98 712	8	100	80 87 080	2100	1050	12	109.86	125.8	82	40	60	80	88	2	88.0	220.0	332.0	9.50	

* Torques based on using hardened and ground racks.



Max. Pre-Load Torque T_{v max.}

Module	T _{v max.}	Disk Spring Layers	Tightening of Adjusting Nut
2	67 Nm	single	14 Graduation Marks
3	125 Nm	double	6 Graduation Marks
4	192 Nm	triple	7 Graduation Marks
5	325 Nm	double	3 Graduation Marks
6	487 Nm	double	5 Graduation Marks
8	550 Nm	double	3 Graduation Marks
8	1050 Nm	double	6 Graduation Marks

Note: Stronger pre-load is obtainable by means of multiple spring layers, but then T_{v max.} has to be smaller. Disk springs can also be ordered separately.

How to adjust the pre-load pinion shaft, see page GG-6.

Calculation of Center Distance "a" between pinion and rack.

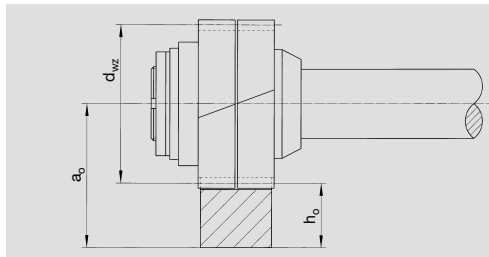

$$a_o = \frac{d_{wz}}{2} + h_o$$

m	a	x	h _o
2	53.83	-	22
3	57.83	-	26
4	66.83	-	35
5	76.29	0.5	34
6	87.38	0.5	43
8	125.93	0.5	71



Description of Operation

Pre-load pinion shafts consist of an output shaft, a helical split pinion and a pre-load unit. The split pinion is manufactured as a unit with an axial distance of $s = 1 \text{ mm}$ ($m = 2...4$) and $s = 2 \text{ mm}$ ($m = 5...8$). By reducing the distance between the pinions (axial displacement of the outer pinion) the backlash is reduced and pre-load initiated when teeth are in mesh with the rack. A defined pre-load torque between rack and split pinion can be produced by means of the pre-load unit.

Adjusting Instructions

The pre-load unit consists of:

- an adjusting nut which is secured against turning by means of a safety washer and a countersunk screw
- a disk spring assembly
- a thrust plate.

The reverse side of the thrust plate is provided with 24 marks at $m = 2...4$ and 12 at $m = 5...8$, and the adjusting nut with 4 marks (graduations).

1. Determine the optimal tooth contact with non-preloaded split-pinion shaft. For this purpose mount the pinion shaft with gap „s“ (see above).
2. The backlash between rack and split pinion should be $< 0.1 \text{ mm}$.
3. Tighten the adjusting nut (loosen the countersunk screw) until no backlash remains. The two flanks of the split pinion should be in mutual contact. This can be checked by scanning the tooth flanks with a dial indicator.
4. The specified degree of pre-load (T_v) can be produced by turning the adjusting nut by a definite number of graduation marks (TS) (see adjusting diagram).

The pre-load torque „ T_v “ is the torque which ensures backlash-free positioning of the rack and pinion drive. The transmissible torque outside the positioning points „ $T_{2\text{max}}$.“ can be determined according to the following formula:

$$T_{2\text{max.}} = T_2 - T_v$$

If: $T_{v \text{ max.}} = T_{2 \text{ max.}}$ the drive is free from play throughout the travelling distance.

Attention: The pre-load is adjusted in assembled condition; therefore the front side of the pinion shaft must be accessible.

To adjust the pre-load, we recommend our adjusting wrench (page GG-8).

Lubrication Recommendations

Felt gearwheel or sliding brush with grease supply by means of an electronically controlled lubricator. Due to the elasticity of the teeth, the felt gearwheels can be used even with maximum backlash compensation. Lubricants see Servo-Catalog page ZE-2 to ZE-9.

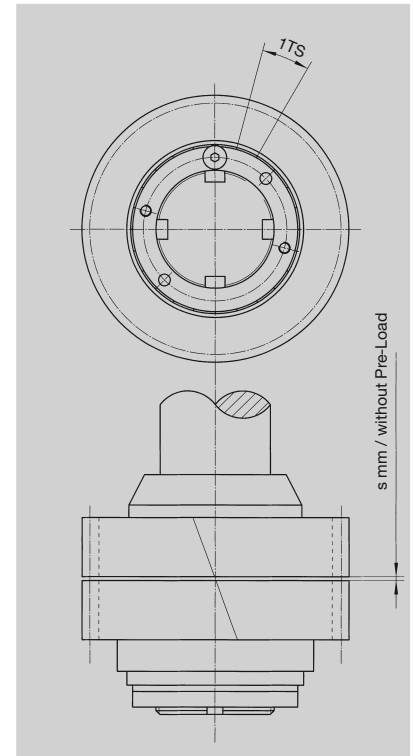

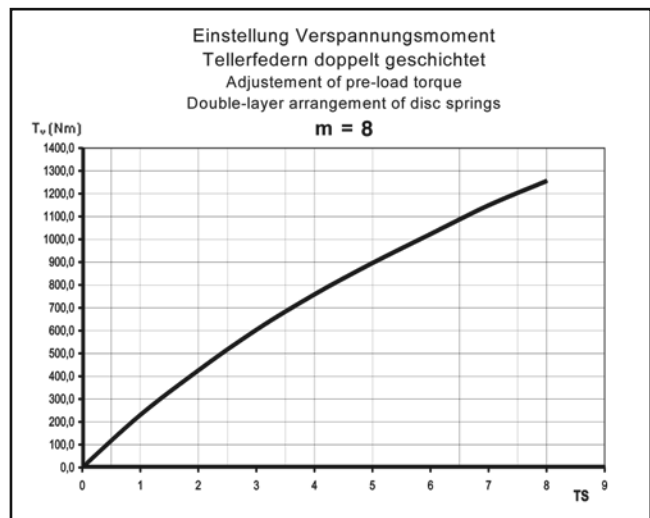
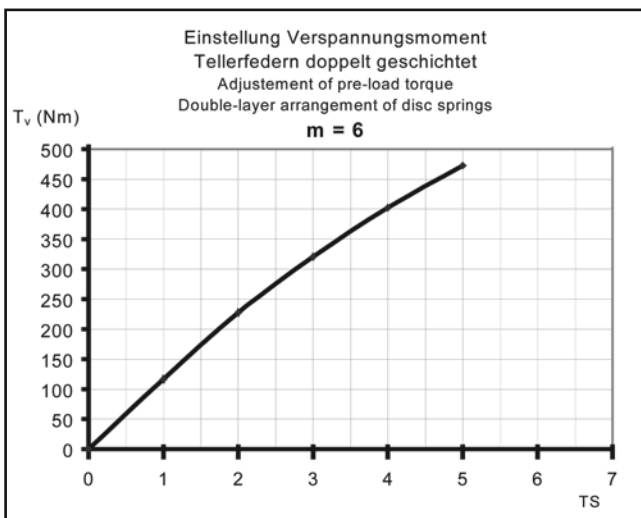
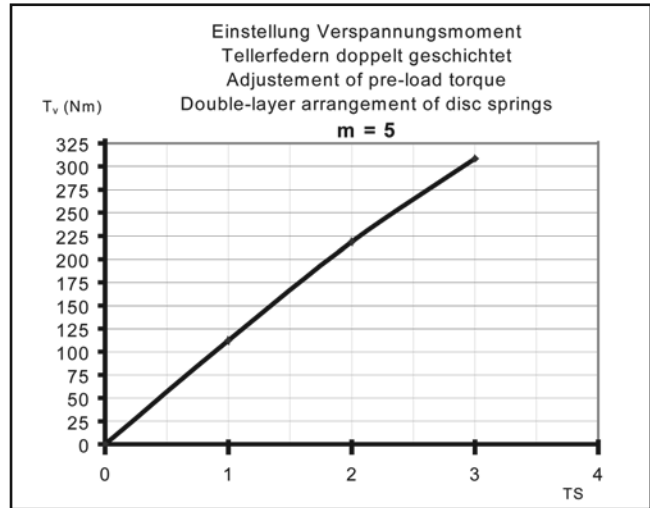
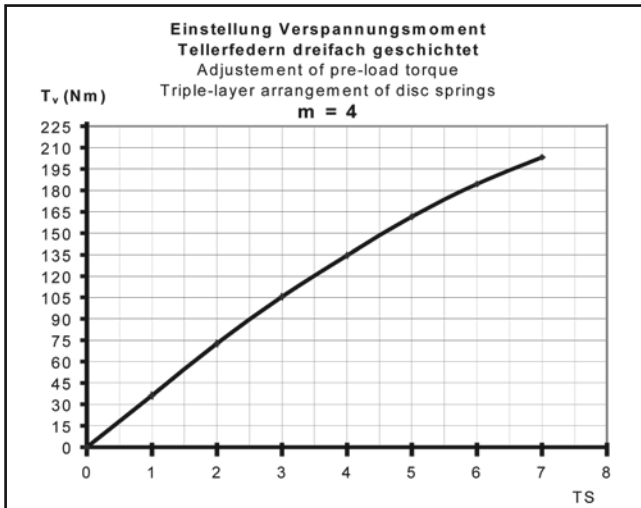
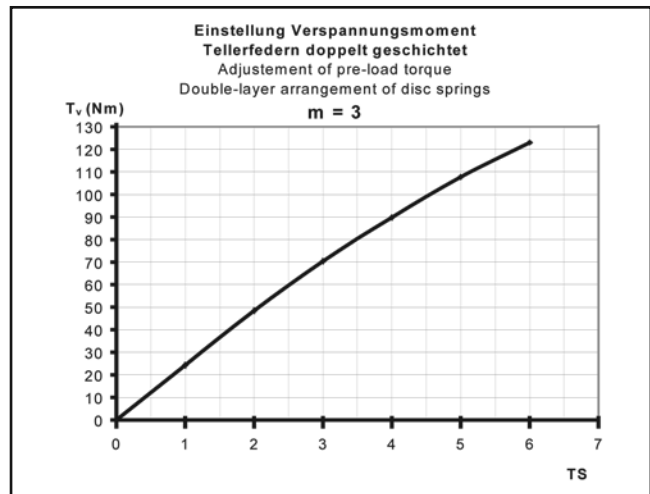
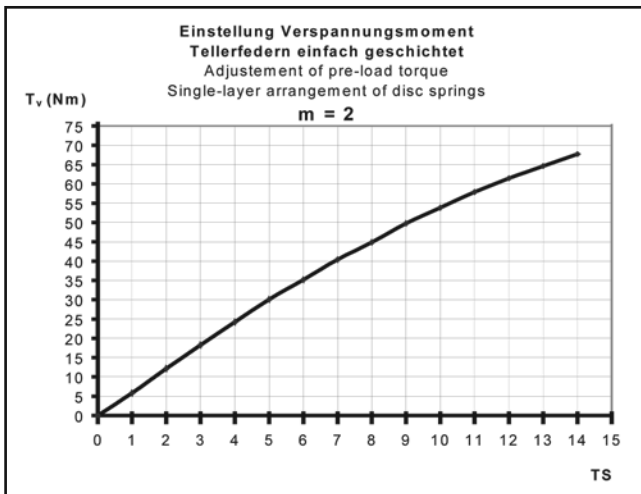

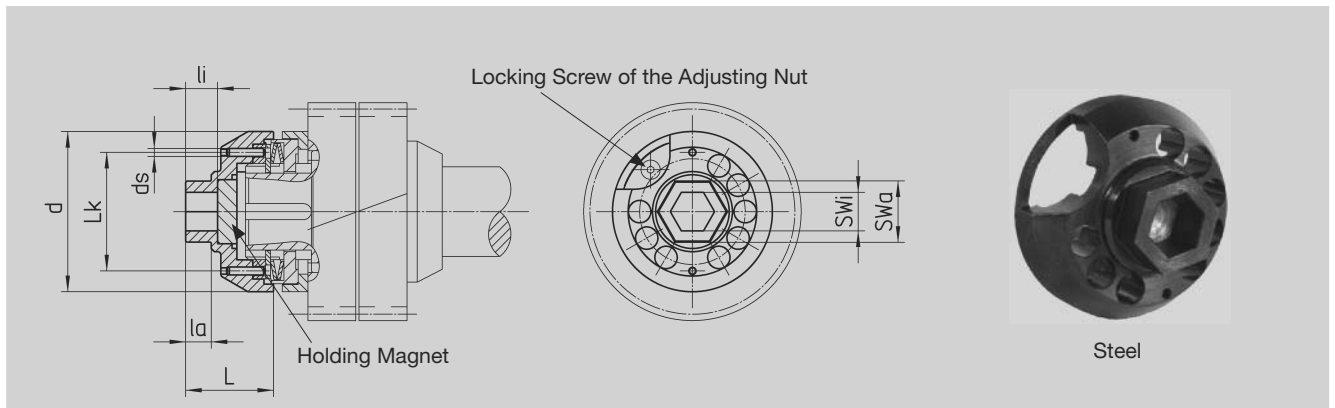

Order Code	Pre-Load $T_{2\max}$ Pinion Shafts	SWa	la	SWi	li	ds	Lk	d	L	kg
74 90 001	74 92 330	19	8	12	10.0	2.5	37	50	27.5	0.113
	74 92 430									
	74 93 320									
	74 93 420									
	74 93 520									
74 94 515										
74 90 002	74 95 615	19	8	12	12.5	4.0	50	74	34.0	0.338
	74 96 613									
	74 96 713									
74 90 003	74 98 612	22	9	12	13.0	6.0	67	96	40.0	0.625
	74 98 712									

Attention:

Apply the adjusting wrench by hand.

Be careful to position the adjusting wrench correctly in relation to the locking screw.

Pins must engage the adjusting nut (do not tap).

The holding magnet holds the adjusting wrench in position.

Loosen the locking screw by the adjusting nut.

Mind the functional characteristics and adjusting instructions for making the adjustment.

Use the Allen wrench with width over flats SWi or the fork wrench with width over flats SWa for turning the adjusting wrench.

Tighten the locking screw by the adjusting nut.



For Output Drive Shafts of Gear Series HT, HP, E, B, BG and Gearwheels with Ground Teeth

Supplied as Complete Set

$$J_{red} = \frac{J}{i^2}$$

Order Code	$T_{2\max}$ (Nm)	d_2	d_1	d_3	D	L_1	L_2	L_3	l	G	J 10 ⁻⁴ kg m ²	kg
80 81 024	270	20	24	36	50.2	23.0	19.5	7.60	14.0	5 x M5	0.780	0.2
80 83 030	400	25	30	44	60.2	25.0	21.5	9.00	18.0	7 x M5	1.756	0.3
	200	19										
	130	16										
80 84 036	540	28	36	52	72.2	27.5	23.5	10.00	22.0	5 x M6	4.029	0.4
	270	22										
80 80 044	870	33	44	61	80.2	29.5	25.5	11.00	22.0	7 x M6	6.524	0.6
	810	32										
	490	25										
80 85 050	1350	38	50	72	90.2	31.5	27.5	12.00	22.0	9 x M6	11.322	0.8
	1180	36										
	870	32										
	730	30										
80 80 055	1480	44	55	75	100.2	34.5	30.5	13.00	23.0	8 x M6	18.729	1.1
	810	35										
	630	32										
80 86 062	2300	48	62	89	110.2	34.5	30.5	13.00	22.0	12 x M6	27.137	1.3
	1420	40										
80 80 068	1940	50	68	86	115.2	34.5	30.5	13.00	22.0	10 x M6	31.648	1.4
	1490	45										
80 87 080	3240	60	80	100	145.3	38.0	32.5	14.00	22.0	7 x M8	88.870	1.9
	2580	55										
80 80 110	7710	75	110	145	185.2	57.0	50.0	22.00	39.0	10 x M10	351.503	5.9
80 80 125	11080	85	125	160	215.3	61.0	54.6	23.00	42.0	12 x M10	664.000	8.3



Description

The series 24 cylindrical gears (pages ZA-24 to ZA-27 and ZB-21 to ZB-27) can be fitted on shafts (tolerance h7) either with key or with shrink plate fitting proceed as follows:

Mounting

Slide shrink plate onto cylindrical gear hub (do not tighten the screws before). Push the cylindrical gear on the shaft up to a stop or the desired position. Now make the transverse pressure connection by uniformly tightening the clamping bolts. Tighten the bolts on after the other in several passes to the correct torque specified in the table (do not tighten crosswise). Check the torque with an indicating torque wrench.



Servo-Motor Mounting Guide for HT and HP Servo-Worm Gear Units

The pairing of servo-motors to servo-worm reducers only considers the servo shaft and flange dimensions; the servo-motor performance with the reducer must also be checked, as well as the individual application requirements.

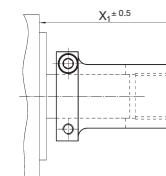

* Coupling to stop

Center Distance 50

Motor Sizes						Gearbox							
Shaft-Ø	Shaft Length	Pilot-Ø	Max. Length of Pilot	Bolt Circle	Fixing Screw	Coupling	Add. Flange	Motor Flange	HT-Servo EN ISO 9409	Gearbox Clamp Connection	HP-Servo Key Way	Gearbox Clamp Connection	Dimension for Coupling x1
10	32	80	6	100	M6	65 43 110		65 59 303	98 03 0xx	98 13 0xx	58 03 0xx	58 13 0xx	*
11	23	60	6	75	M8	65 43 111		65 59 306	98 03 0xx	98 13 0xx	58 03 0xx	58 13 0xx	*
11	23	60	6	90	M5	65 43 111	265 23 085	65 59 301	98 03 0xx	98 13 0xx	58 03 0xx	58 13 0xx	68
11	23	60	6	90	M5	65 43 111	265 23 085	65 59 301	98 03 0xx	98 13 0xx	58 03 0xx	58 13 0xx	*
11	25	60	4	75	M8	65 43 111		65 59 306	98 03 0xx	98 13 0xx	58 03 0xx	58 13 0xx	*
11	30	50	6	70	M4	65 43 111	265 23 084	65 59 301	98 03 0xx	98 13 0xx	58 03 0xx	58 13 0xx	*
11	30	80	4	100	M6	65 43 111	265 24 108	65 59 303	98 03 0xx	98 13 0xx	58 03 0xx	58 13 0xx	*
14	30	50	6	70	M5	65 43 914	265 23 087	65 59 301	98 03 0xx	98 13 0xx	58 03 0xx	58 13 0xx	*
14	30	50	4	95	M6	65 43 114		65 59 302	98 03 0xx	98 13 0xx	58 03 0xx	58 13 0xx	*
14	30	60	6	75	M8	65 43 914		65 59 306	98 03 0xx	98 13 0xx	58 03 0xx	58 13 0xx	*
14	30	70	4	90	M5	65 43 914	265 23 086	65 59 301	98 03 0xx	98 13 0xx	58 03 0xx	58 03 0xx	72
14	30	70	3.5	90	M6	65 43 914	265 23 096	65 59 301	98 03 0xx	98 13 0xx	58 03 0xx	58 13 0xx	*
14	30	80	6	100	M6	65 43 114		65 59 303	98 03 0xx	98 13 0xx	58 03 0xx	58 13 0xx	*
14	30	95	6	115	M8	65 43 114		65 59 301	98 03 0xx	98 13 0xx	58 03 0xx	58 13 0xx	*
16	40	60	6	75	M8	65 43 116		65 59 306	98 03 0xx	98 13 0xx	58 03 0xx	58 13 0xx	68
16	40	95	6	115	M8	65 43 116		65 59 301	98 03 0xx	98 13 0xx	58 03 0xx	58 13 0xx	*
16	40	70	6	90	M6	65 43 116	265 23 096	65 59 301	98 03 0xx	98 13 0xx	58 03 0xx	58 13 0xx	66
16	40	110	4	145	M8	65 43 916	265 23 081	65 59 305			58 03 0xx	58 13 0xx	*
16	43	95	4	115	M8	65 43 116	265 23 099	65 59 301	98 03 0xx	98 13 0xx	58 03 0xx	58 13 0xx	*
16	43	95	4	115	M8	65 43 116	265 23 099	65 59 305			58 03 0xx	58 13 0xx	*
19	35	70	6	90	M6	65 43 919	265 23 096	65 59 301	98 03 0xx	98 13 0xx	58 03 0xx	58 13 0xx	*
19	40	70	6	90	M5	65 43 919	265 23 086	65 59 301	98 03 0xx	98 13 0xx	58 03 0xx	58 13 0xx	*
19	40	80	6	100	M6	65 43 119		65 59 303	98 03 0xx	98 13 0xx	58 03 0xx	58 13 0xx	*
19	40	95	6	115	M8	65 43 119		65 59 301	98 03 0xx	98 13 0xx	58 03 0xx	58 13 0xx	*
19	40	95	6	130	M8	65 43 919		65 59 304	98 03 0xx	98 13 0xx	58 03 0xx	58 13 0xx	*
19	40	95	6	130	M8	65 43 919		65 59 304	98 03 0xx	98 13 0xx	58 03 0xx	58 13 0xx	*
19	40	95	6	115	M8	65 43 919	265 21 096	65 59 306	98 03 0xx	98 13 0xx	58 03 0xx	58 13 0xx	80
19	40	110	6	130	M8	65 43 919		65 59 402	98 03 0xx	98 13 0xx	58 03 0xx	58 13 0xx	*
19	50	95	6	115	M8	65 43 119		65 59 305			58 03 0xx	58 13 0xx	*
19	50	110	6	145	M8	65 43 119	265 23 095	65 59 301	98 03 0xx	98 13 0xx	58 03 0xx	58 13 0xx	*
19	55	80	6	100	M6	65 43 919	265 24 089	65 59 304	98 03 0xx	98 13 0xx	58 03 0xx	58 13 0xx	87
19	55	95	4	115	M8	65 43 119	265 23 088	65 59 301	98 03 0xx	98 13 0xx	58 03 0xx	58 13 0xx	*
24	50	95	3	115	M8	65 43 924	265 24 091	65 59 305	98 03 0xx	98 13 0xx	58 03 0xx	58 13 0xx	*
24	55	110	6	145	M8	65 43 924	265 24 084	65 59 301	98 03 0xx	98 13 0xx	58 03 0xx	58 13 0xx	82





ATLANTA

Servo-Motor Mounting Guide for HT and HP Servo-Worm Gear Units

Further information see next page.

* Coupling to stop

Center Distance 63

Motor Sizes						Gearbox							
Shaft-Ø	Shaft Length	Pilot-Ø	Max. Length of Pilot	Bolt Circle	Fixing Screw	Coupling	Add. Flange	Motor Flange	HT-Servo EN ISO 9409	Gearbox Clamp Connection	HP-Servo Key Way	Gearbox Clamp Connection	Dimension for Coupling x1
14	30	50	6	70	M5	535 72 075	265 23 087	65 59 401	98 04 0xx	98 14 0xx	58 04 0xx	58 14 0xx	*
14	30	50	6	95	M6	65 44 114	265 23 096	65 59 404	98 04 0xx	98 14 0xx	58 04 0xx	58 14 0xx	60
14	30	60	4	75	M5	535 72 075	265 23 094	65 59 401	98 04 0xx	98 14 0xx	58 04 0xx	58 14 0xx	*
14	30	80	6	100	M6	535 72 075	265 24 089	65 59 403	98 04 0xx	98 14 0xx	58 04 0xx	58 14 0xx	*
14	30	95	4	115	M8	65 44 114		65 59 401	98 04 0xx	98 14 0xx	58 04 0xx	58 14 0xx	*
19	28	130	4	165	M10	65 44 219		65 59 407	98 04 0xx	98 14 0xx	58 04 0xx	58 14 0xx	*
19	35	70	6	90	M6	65 44 219	265 23 096	65 59 401	98 04 0xx	98 14 0xx	58 04 0xx	58 14 0xx	*
19	37.5	95	4	100	M8	65 44 119		65 59 401	98 04 0xx	98 14 0xx	58 04 0xx	58 14 0xx	*
19	40	70	6	90	M6	65 44 119	265 23 096	65 59 401	98 04 0xx	98 14 0xx	58 04 0xx	58 14 0xx	72.5
19	40	80	6	100	M6	65 44 919	265 24 089	65 59 403	98 04 0xx	98 14 0xx	58 04 0xx	58 14 0xx	*
19	40	95	4	115	M8	65 44 119		65 59 401	98 04 0xx	98 14 0xx	58 04 0xx	58 14 0xx	*
19	40	95	4	130	M8	65 44 119		65 59 403	98 04 0xx	98 14 0xx	58 04 0xx	58 14 0xx	*
19	40	110	4	130	M8	65 44 119		65 59 404	98 04 0xx	98 14 0xx	58 04 0xx	58 14 0xx	*
19	40	110	6	145	M8	65 44 919	265 24 093	65 59 401	98 04 0xx	98 14 0xx	58 04 0xx	58 14 0xx	*
19	40	130	4	165	M10	65 44 119		65 59 407	98 04 0xx	98 14 0xx	58 04 0xx	58 14 0xx	*
19	40	110	5	215	M12	65 44 919	265 25 099	65 59 406	98 04 0xx	98 14 0xx	58 04 0xx	58 14 0xx	*
19	46	130	4	165	M10	65 44 119		65 59 407	98 04 0xx	98 14 0xx	58 04 0xx	58 14 0xx	*
19	50	110	6	145	M8	65 44 119	265 24 093	65 59 401	98 04 0xx	98 14 0xx	58 04 0xx	58 14 0xx	84
19	55	95	4	115	M8	65 44 119	265 23 088	65 59 401	98 04 0xx	98 14 0xx	58 04 0xx	58 14 0xx	*
19	58	110	6	145	M8	65 44 119	265 24 093	65 59 401	98 04 0xx	98 14 0xx	58 04 0xx	58 14 0xx	88
22	53.5	130	4	165	M10	581 24 001		65 59 409	98 04 0xx	98 14 0xx	58 04 0xx	58 14 0xx	91
22	55	110	6	145	M8	581 24 001	265 24 093	65 59 401	98 04 0xx	98 14 0xx	58 04 0xx	58 14 0xx	90
22	58	110	6	145	M8	581 24 001	265 24 093	65 59 401	98 04 0xx	98 14 0xx	58 04 0xx	58 14 0xx	97
24	50	95	3	115	M8	65 44 024	265 24 091	65 59 401	98 04 0xx	98 14 0xx	58 04 0xx	58 14 0xx	*
24	50	110	5	130	M8	65 44 024		65 59 402	98 04 0xx	98 14 0xx	58 04 0xx	58 14 0xx	*
24	50	110	5	165	M10	65 44 024		65 59 406	98 04 0xx	98 14 0xx	58 04 0xx	58 14 0xx	*
24	50	130	4	165	M10	65 44 024		65 59 407	98 04 0xx	98 14 0xx	58 04 0xx	58 14 0xx	*
24	55	110	6	145	M8	65 44 024	265 24 093	65 59 401	98 04 0xx	98 14 0xx	58 04 0xx	58 14 0xx	85
28	58	130	4	165	M10	65 44 928		65 59 409	98 04 0xx	98 14 0xx	58 04 0xx	58 14 0xx	*
28	60	130	4	165	M10	65 44 928		65 59 409	98 04 0xx	98 14 0xx	58 04 0xx	58 14 0xx	*
32	50	130	4	165	M10	65 44 932		65 59 409	98 04 0xx	98 14 0xx	58 04 0xx	58 14 0xx	*
32	58	130	4	165	M10	65 44 932		65 59 409	98 04 0xx	98 14 0xx	58 04 0xx	58 14 0xx	*
32	58	130	5	215	M12	65 44 932	265 25 099	65 59 406	98 04 0xx	98 14 0xx	58 04 0xx	58 14 0xx	*
32	58	180	6	215	M12	65 44 932	265 26 098	65 59 406	98 04 0xx	98 14 0xx	58 04 0xx	58 14 0xx	105
32	60	130	5	215	M12	65 44 932	265 25 099	65 59 406	98 04 0xx	98 14 0xx	58 04 0xx	58 14 0xx	*
32	60	180	6	215	M12	65 44 932	265 26 098	65 59 406	98 04 0xx	98 14 0xx	58 04 0xx	58 14 0xx	105
35	79	114.3	4	200	M12	65 44 935	265 26 089	65 59 406	98 04 0xx	98 14 0xx	58 04 0xx	58 14 0xx	*
35	80	114.3	4	200	M12	65 44 935	265 26 088	65 59 406	98 04 0xx	98 14 0xx	58 04 0xx	58 14 0xx	110



Servo-Motor Mounting Guide for HT and HP Servo-Worm Gear Units

The pairing of servo-motors to servo-worm reducers only considers the servo shaft and flange dimensions; the servo-motor performance with the reducer must also be checked, as well as the individual application requirements.

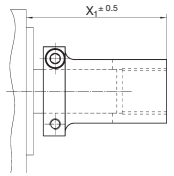

* Coupling to stop

Center Distance 80

Motor Sizes						Gearbox							
Shaft-Ø	Shaft Length	Pilot-Ø	Max. Length of Pilot	Bolt Circle	Fixing Screw	Coupling	Add. Flange	Motor Flange	HT-Servo EN ISO 9409	Gearbox Clamp Connection	HP-Servo Key Way	Gearbox Clamp Connection	Dimension for Coupling x1
19	40	70	3	90	M6	581 20 002	265 25 104	65 59 501	98 05 0xx	98 15 0xx	58 05 0xx	58 15 0xx	*
19	40	80	4	100	M6	581 20 002	265 25 094	65 59 501	98 05 0xx	98 15 0xx	58 05 0xx	58 15 0xx	*
19	40	95	6	115	M8	581 20 002	265 25 092	65 59 501	98 05 0xx	98 15 0xx	58 05 0xx	58 15 0xx	*
19	40	95	6	130	M8	581 20 002	265 25 093	65 59 501	98 05 0xx	98 15 0xx	58 05 0xx	58 15 0xx	*
19	40	110	4	130	M8	581 20 002	265 25 090	65 59 501	98 05 0xx	98 15 0xx	58 05 0xx	58 15 0xx	*
19	46	130	5	165	M10	581 20 002		65 59 507	98 05 0xx	98 15 0xx	58 05 0xx	58 15 0xx	*
19	55	95	6	115	M8	581 20 002	265 24 099	65 59 507	98 05 0xx	98 15 0xx	58 05 0xx	58 15 0xx	*
22	53.5	130	5	165	M10	528 44 005		65 59 507	98 05 0xx	98 15 0xx	58 05 0xx	58 15 0xx	*
22	55	110	6	145	M8	502 27 047	265 25 081	65 59 505	98 05 0xx	98 15 0xx	58 05 0xx	58 15 0xx	117
22	58	110	6	145	M8	502 27 047	265 25 081	65 59 505	98 05 0xx	98 15 0xx	58 05 0xx	58 15 0xx	117
24	40	110	6	165	M10	65 46 024		65 59 501	98 05 0xx	98 15 0xx	58 05 0xx	58 15 0xx	82
24	50	110	6	165	M10	65 46 024		65 59 501	98 05 0xx	98 15 0xx	58 05 0xx	58 15 0xx	*
24	50	130	4	165	M10	65 46 024		65 59 502	98 05 0xx	98 15 0xx	58 05 0xx	58 15 0xx	*
28	42	180	5	215	M12	65 46 928		65 59 505	98 05 0xx	98 15 0xx	58 05 0xx	58 15 0xx	*
28	58	130	5	165	M10	65 46 928		65 59 507	98 05 0xx	98 05 0xx	58 05 0xx	58 15 0xx	*
28	58	180	5	215	M12	65 46 928		65 59 505	98 05 0xx	98 15 0xx	58 05 0xx	58 15 0xx	*
28	60	180	5	215	M12	65 46 928		65 59 505	98 05 0xx	98 15 0xx	58 05 0xx	58 15 0xx	*
32	50	130	5	165	M10	65 46 932		65 59 507	98 05 0xx	98 15 0xx	58 05 0xx	58 15 0xx	103
32	58	130	5	165	M10	65 46 932		65 59 507	98 05 0xx	98 15 0xx	58 05 0xx	58 15 0xx	*
32	58	130	5	215	M12	65 46 932		65 59 506	98 05 0xx	98 15 0xx	58 05 0xx	58 15 0xx	*
32	58	180	5	215	M12	65 46 932		65 59 505	98 05 0xx	98 15 0xx	58 05 0xx	58 15 0xx	*
32	60	130	5	215	M12	65 46 932		65 59 506	98 05 0xx	98 15 0xx	58 05 0xx	58 15 0xx	*
32	60	180	5	215	M12	65 46 932		65 59 505	98 05 0xx	98 15 0xx	58 05 0xx	58 15 0xx	*
35	79-80	114.3	4	200	M12	65 46 935	265 26 089	65 59 501	98 05 0xx	98 15 0xx	58 05 0xx	58 15 0xx	*
38	80	180	5	215	M12	65 46 938		65 59 504	98 05 0xx	98 15 0xx	58 05 0xx	58 15 0xx	*
42	110	250	6	300	M16	505 33 019	265 27 028	65 59 504	98 05 0xx	98 15 0xx	58 05 0xx	58 15 0xx	149





ATLANTA

Servo-Motor Mounting Guide for HT and HP Servo-Worm Gear Units

The pairing of servo-motors to servo-worm reducers only considers the servo shaft and flange dimensions; the servo-motor performance with the reducer must also be checked, as well as the individual application requirements.

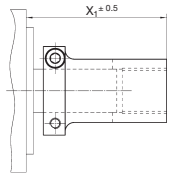

* Coupling to stop

Center Distance 100

Shaft-Ø	Shaft Length	Motor Sizes				Fixing Screw	Coupling	Add. Flange	Motor Flange	Gearbox				Dimension for Coupling x1
		Pilot-Ø	Max. Length of Pilot	Bolt Circle						HT-Servo Gearbox EN ISO 9409	Clamp Connection	HP-Servo Gearbox Key Way	Clamp Connection	
19	40	80	5	100	M6	502 27 026	265 25 109	65 59 501	98 06 0xx	98 16 0xx	58 06 0xx	98 16 0xx	97	
19	40	95	6	115	M8	581 20 002	265 25 092	65 59 501	98 06 0xx	98 16 0xx	58 06 0xx	58 16 0xx	*	
19	40	95	6	130	M8	581 20 002	265 25 093	65 59 501	98 06 0xx	98 16 0xx	58 06 0xx	58 16 0xx	*	
19	40	110	4	130	M8	581 20 002	265 25 090	65 59 501	98 06 0xx	98 16 0xx	58 06 0xx	58 16 0xx	*	
19	58	110	6	145	M8	535 72 058	265 25 081	65 59 505	98 06 0xx	98 16 0xx	58 06 0xx	58 16 0xx	*	
24	40	110	4	165	M10	65 46 024		65 59 501	98 06 0xx	98 16 0xx	58 06 0xx	58 16 0xx	82	
24	50	110	6	165	M10	65 46 024		65 59 501	98 06 0xx	98 16 0xx	58 06 0xx	58 16 0xx	*	
24	50	130	4	165	M10	65 46 024		65 59 502	98 06 0xx	98 16 0xx	58 06 0xx	58 16 0xx	*	
28	58	180	4	215	M12	65 46 928		65 59 505	98 06 0xx	98 16 0xx	58 06 0xx	58 16 0xx	*	
28	60	130	4	165	M10	65 46 928		65 59 507	98 06 0xx	98 16 0xx	58 06 0xx	58 16 0xx	*	
28	60	180	4	215	M12	65 46 928		65 59 505	98 06 0xx	98 16 0xx	58 06 0xx	58 16 0xx	*	
32	50	130	4	165	M10	65 46 932		65 59 507	98 06 0xx	98 16 0xx	58 06 0xx	58 16 0xx	100	
32	58	130	4	165	M10	65 46 932		65 59 507	98 06 0xx	98 16 0xx	58 06 0xx	58 16 0xx	*	
32	58	130	4	215	M12	65 46 932		65 59 506	98 06 0xx	98 16 0xx	58 06 0xx	58 16 0xx	*	
32	58	180	4	215	M12	65 46 932		65 59 505	98 06 0xx	98 16 0xx	58 06 0xx	58 16 0xx	*	
32	60	130	4	215	M12	65 46 932		65 59 506	98 06 0xx	98 16 0xx	58 06 0xx	58 16 0xx	*	
32	60	180	4	215	M12	65 46 932		65 59 505	98 06 0xx	98 16 0xx	58 06 0xx	58 16 0xx	*	
35	79-80	114.3	4	200	M12	65 46 935	265 26 089	65 59 501	98 06 0xx	98 16 0xx	58 06 0xx	58 16 0xx	*	
38	80	180	6	215	M12	65 46 938		65 59 504	98 06 0xx	98 16 0xx	58 06 0xx	58 16 0xx	*	
42	110	250	6	300	M16	505 33 019	265 27 028	65 59 504	98 06 0xx	98 16 0xx	58 06 0xx	58 16 0xx	149	

Center Distance 125

28	60	180	6	215	M12	65 46 928					58 47 0xx	58 87 0xx	*
32	60	180	6	215	M12	65 46 932					58 47 0xx	58 87 0xx	*
38	80	180	6	215	M12	65 46 938					58 47 1xx	58 87 1xx	*
48	58	180	6	215	M12	65 47 948					58 47 0xx	58 87 0xx	*
48	80 - 85	180	6	215	M12	65 47 948					58 47 1xx	58 87 1xx	*



ATLANTA

Servo-Motor Mounting Guide for E, B and BG Servo-Worm Gear Units

The pairing of servo-motors to servo-worm gear units only considers the servo shaft and flange dimensions; the servo-motor performance with the gear units must also be checked, as well as the individual application requirements.

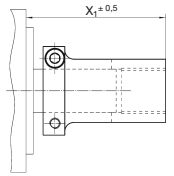

* Coupling to stop

Center Distance 32

Motor Sizes						Gearbox									
Shaft-Ø	Shaft Length	Pilot-Ø	Max. Length of Pilot	Bolt Circle	Fixing Srew	Coupling	Add. Flange	Motor Flange	E Servo Gearbox Key Way	E Servo Gearbox Clamp Connection	B Servo Gearbox Key Way	B Servo Gearbox Clamp Connection	BG Servo Gearbox Key Way	BG Servo Gearbox Clamp Connection	Dimen. for coupl. x1
8	25	30	2.5	46	M4	65 51 008	265 23 076	65 59 103	59 01 0xx	59 16 0xx	57 01 0xx	57 16 0xx			59
9	20	40	2.5	63	M5	65 51 009		65 59 101	59 01 0xx	59 11 0xx	57 01 0xx	57 11 0xx			49
9	24	40	2.5	63	M5	65 51 009		65 59 101	59 01 0xx	59 11 0xx	57 01 0xx	57 11 0xx			49
10	32	80	4	100	M6	65 51 010		65 59 104	59 01 0xx	59 11 0xx	57 01 0xx	57 11 0xx			56
11	23	60	3.5	75	M5	65 51 011		65 59 103	59 01 0xx	59 11 0xx	57 01 0xx	57 11 0xx			51
11	23	60	5	90	M5	65 51 011		5 02 99 001	59 01 0xx	59 11 0xx	57 01 0xx	57 11 0xx			50
11	30	50	4	70	M5	65 51 011		65 59 102	59 01 0xx	59 11 0xx	57 01 0xx	57 11 0xx			56
11	30	80	3	100	M6	65 51 011		65 59 104	59 01 0xx	59 11 0xx	57 01 0xx	57 11 0xx			56
14	30	50	4	70	M5	65 51 014		65 59 102	59 01 0xx	59 11 0xx	57 01 0xx	57 11 0xx			56
14	30	50	5	95	M6	65 51 014	265 21 078	65 59 103	59 01 0xx	59 11 0xx	57 01 0xx	57 11 0xx			62
14	30	60	3.5	75	M5	65 51 014		65 59 103	59 01 0xx	59 11 0xx	57 01 0xx	57 11 0xx			52
14	30	60	5	90	M5	65 51 014		5 02 99 001	59 01 0xx	59 11 0xx	57 01 0xx	57 11 0xx			52
14	30	70	4	90	M5	65 51 014	265 21 098	65 59 102	59 01 0xx	59 11 0xx	57 01 0xx	57 11 0xx			64
14	30	80	5	100	M6	65 51 014		65 59 104	59 01 0xx	59 11 0xx	57 01 0xx	57 11 0xx			56
16	35	80	5	100	M6	65 51 016		65 59 104	59 01 0xx	59 11 0xx	57 01 0xx	57 11 0xx			56
16	40	70	5	90	M6	65 51 016	265 21 097	65 59 102	59 01 0xx	59 11 0xx	57 01 0xx	57 11 0xx			71
16	40	80	5	100	M6	65 51 016		65 59 104	59 01 0xx	59 11 0xx	57 01 0xx	57 11 0xx			56
19	40	80	5	100	M6	65 53 019		65 59 104	59 01 0xx	59 11 0xx	57 01 0xx	57 11 0xx			56
19	40	95	5	115	M8	65 53 019	265 21 096	65 59 103	59 01 0xx	59 11 0xx	57 01 0xx	57 11 0xx			67





ATLANTA

Servo-Motor Mounting Guide for E, B and BG Servo-Worm Gear Units

Further information see page GI - 8.

* Coupling to stop

Center Distance 50

Motor Sizes						Gearbox										Dimen. for coupl. x1
Shaft-Ø	Shaft Length	Pilot-Ø	Max. Length of Pilot	Bolt Circle	Fixing Srew	Coupling	Add. Flange	Motor Flange	E Servo Gearbox		B Servo Gearbox		BG Servo Gearbox			
									Key Way	Clamp Connection	Key Way	Clamp Connection	Key Way	Clamp Connection		
10	32	80	6	100	M6	65 51 010		65 59 303	59 03 0xx	59 13 0xx	57 03 0xx	57 13 0xx	51 03 0xx	51 13 0xx	56	
11	23	60	7	75	M5	65 43 111		65 59 306	59 03 0xx	59 13 0xx	57 03 0xx	57 13 0xx	51 03 0xx	51 13 0xx	*	
11	23	60	6	90	M5	65 43 111	265 23 085	65 59 301	59 03 0xx	59 13 0xx	57 03 0xx	57 13 0xx	51 03 0xx	51 13 0xx	*	
11	23	95	6	115	M8	65 51 011		65 59 301	59 03 0xx	59 13 0xx	57 03 0xx	57 13 0xx	51 03 0xx	51 13 0xx	51	
11	25	60	6	75	M5	65 43 111		65 59 306	59 03 0xx	59 13 0xx	57 03 0xx	57 13 0xx	51 03 0xx	51 13 0xx	68.5	
11	30	50	6	70	M4	65 43 111	265 23 084	65 59 301	59 03 0xx	59 13 0xx	57 03 0xx	57 13 0xx	51 03 0xx	51 13 0xx	*	
11	30	80	6	100	M6	65 51 011		65 59 303	59 03 0xx	59 13 0xx	57 03 0xx	57 13 0xx	51 03 0xx	51 13 0xx	56	
14	30	50	6	70	M5	65 43 914	265 23 087	65 59 301	59 03 0xx	59 13 0xx	57 03 0xx	57 13 0xx	51 03 0xx	51 13 0xx	*	
14	30	50	6	95	M6	65 51 014		65 59 302	59 03 0xx	59 13 0xx	57 03 0xx	57 13 0xx	51 03 0xx	51 13 0xx	56	
14	30	60	7	75	M5	65 43 914		65 59 306	59 03 0xx	59 13 0xx	57 03 0xx	57 13 0xx	51 03 0xx	51 13 0xx	*	
14	30	70	6	90	M5	65 43 914	265 23 086	65 59 301	59 03 0xx	59 13 0xx	57 03 0xx	57 13 0xx	51 03 0xx	51 13 0xx	*	
14	30	80	6	100	M6	65 51 014		65 59 303	59 03 0xx	59 13 0xx	57 03 0xx	57 13 0xx	51 03 0xx	51 13 0xx	56	
14	30	95	6	115	M8	65 51 014		65 59 301	59 03 0xx	59 13 0xx	57 03 0xx	57 13 0xx	51 03 0xx	51 13 0xx	56	
16	35	80	6	100	M6	65 51 016		65 59 303	59 03 0xx	59 13 0xx	57 03 0xx	57 13 0xx	51 03 0xx	51 13 0xx	56	
16	40	60	7	75	M5	65 51 016		65 59 306	59 03 0xx	59 13 0xx	57 03 0xx	57 13 0xx	51 03 0xx	51 13 0xx	68	
16	40	70	7	90	M6	65 51 016		65 59 307	59 03 0xx	59 13 0xx	57 03 0xx	57 13 0xx	51 03 0xx	51 13 0xx	64	
16	40	80	6	100	M6	65 51 016		65 59 303	59 03 0xx	59 13 0xx	57 03 0xx	57 13 0xx	51 03 0xx	51 13 0xx	56	
16	40	110	7	145	M8	65 51 016		65 59 410	59 03 0xx	59 13 0xx	57 03 0xx	57 13 0xx	51 03 0xx	51 13 0xx	68	
16	43	95	5	115	M8	65 51 016	265 23 099	65 59 301	59 03 0xx	59 13 0xx	57 03 0xx	57 13 0xx	51 03 0xx	51 13 0xx	66	
19	35	70	7	90	M6	65 53 019		65 59 307	59 03 0xx	59 13 0xx	57 03 0xx	57 13 0xx	51 03 0xx	51 13 0xx	64	
19	40	70	7	90	M6	65 53 019		65 59 307	59 03 0xx	59 13 0xx	57 03 0xx	57 13 0xx	51 03 0xx	51 13 0xx	64	
19	40	80	6	100	M6	65 53 019		65 59 303	59 03 0xx	59 13 0xx	57 03 0xx	57 13 0xx	51 03 0xx	51 13 0xx	56	
19	40	95	6	115	M8	65 53 019		65 59 301	59 03 0xx	59 13 0xx	57 03 0xx	57 13 0xx	51 03 0xx	51 13 0xx	56	
19	40	95	6	130	M8	65 43 919		65 59 304	59 03 0xx	59 13 0xx	57 03 0xx	57 13 0xx	51 03 0xx	51 13 0xx	*	
19	40	110	7	130	M8	65 53 019		65 59 402	59 03 0xx	59 13 0xx	57 03 0xx	57 13 0xx	51 03 0xx	51 13 0xx	72	
19	40	110	7	145	M8	65 53 019		65 59 410	59 03 0xx	59 13 0xx	57 03 0xx	57 13 0xx	51 03 0xx	51 13 0xx	67	
19	46	130	5	165	M10	65 53 019	265 23 097	65 59 301	59 03 0xx	59 13 0xx	57 03 0xx	57 13 0xx	51 03 0xx	51 13 0xx	72	
19	50	110	6	145	M8	65 53 019	265 23 095	65 59 301	59 03 0xx	59 13 0xx	57 03 0xx	57 13 0xx	51 03 0xx	51 13 0xx	80	
19	55	110	7	145	M8	65 53 019		65 59 411	59 03 0xx	59 13 0xx	57 03 0xx	57 13 0xx	51 03 0xx	51 13 0xx	78	
19	58	110	7	145	M8	65 53 019		65 59 411	59 03 0xx	59 13 0xx	57 03 0xx	57 13 0xx	51 03 0xx	51 13 0xx	78	
22	58	110	7	145	M8	65 53 022		65 59 411	59 03 0xx	59 13 0xx	57 03 0xx	57 13 0xx	51 03 0xx	51 13 0xx	78	
22	55	114.3	7	200	M12	65 53 022		65 59 414	59 03 0xx	59 13 0xx	57 03 0xx	57 13 0xx	51 03 0xx	51 13 0xx	85	
24	50	95	5	115	M8	65 53 024		65 59 305	59 03 0xx	59 13 0xx	57 03 0xx	57 13 0xx	51 03 0xx	51 13 0xx	72.5	
24	55	110	7	145	M8	65 53 024		65 59 411	59 03 0xx	59 13 0xx	57 03 0xx	57 13 0xx	51 03 0xx	51 13 0xx	78	
28	55	110	7	145	M8	65 53 028		65 59 411	59 03 0xx	59 13 0xx	57 03 0xx	57 13 0xx	51 03 0xx	51 13 0xx	78	
28	55	114.3	7	200	M12	65 53 028		65 59 414	59 03 0xx	59 13 0xx	57 03 0xx	57 13 0xx	51 03 0xx	51 13 0xx	85	
35	79	114.3	7	200	M12	65 53 035		65 59 412	59 03 0xx	59 13 0xx	57 03 0xx	57 13 0xx	51 03 0xx	51 13 0xx	98	
35	80	114.3	7	200	M12	65 53 035		65 59 412	59 03 0xx	59 13 0xx	57 03 0xx	57 13 0xx	51 03 0xx	51 13 0xx	98	



ATLANTA

Servo-Motor Mounting Guide for E, B and BG Servo-Worm Gear Units

Further information see page GI – 8.

* Coupling to stop

Center Distance 63

Motor Sizes						Gearbox									Dimen. for coupl. x1
Shaft-Ø	Shaft Length	Pilot-Ø	Max. Length of Pilot	Bolt Circle	Fixing Srew	Coupling	Add. Flange	Motor Flange	E Servo Gearbox Key Way Clamp Connection	B Servo Gearbox Key Way Clamp Connection	BG Servo Gearbox Key Way Clamp Connection				
11	23	95	7	115	M8	65 54 011		65 59 401	59 04 0xx	59 14 0xx	57 04 0xx	57 14 0xx	51 04 0xx	51 14 0xx	71
14	30	50	7	70	M5	535 72 075	265 23 087	65 59 401	59 04 0xx	59 14 0xx	57 04 0xx	57 14 0xx	51 04 0xx	51 14 0xx	80
14	30	50	3	95	M6	65 44 114	265 24 080	65 59 404	59 04 0xx	59 14 0xx	57 04 0xx	57 14 0xx	51 04 0xx	51 14 0xx	70
14	30	60	4	75	M5	65 54 014	265 23 094	65 59 401	59 04 0xx	59 14 0xx	57 04 0xx	57 14 0xx	51 04 0xx	51 14 0xx	76
14	30	80	5	100	M8	65 54 014	265 24 089	65 59 403	59 04 0xx	59 14 0xx	57 04 0xx	57 14 0xx	51 04 0xx	51 14 0xx	80
14	30	95	3	115	M8	65 54 014		65 59 401	59 04 0xx	59 14 0xx	57 04 0xx	57 14 0xx	51 04 0xx	51 14 0xx	72
16	40	80	7	100	M6	65 54 016	265 24 089	65 59 403	59 04 0xx	59 14 0xx	57 04 0xx	57 14 0xx	51 04 0xx	51 14 0xx	87
16	43	95	7	115	M8	65 54 016		65 59 401	59 04 0xx	59 14 0xx	57 04 0xx	57 14 0xx	51 04 0xx	51 14 0xx	68
16	40	110	7	145	M8	65 54 016		65 59 410	59 04 0xx	59 14 0xx	57 04 0xx	57 14 0xx	51 04 0xx	51 14 0xx	70
19	35	70	7	90	M6	65 54 019	265 23 096	65 59 401	59 04 0xx	59 14 0xx	57 04 0xx	57 14 0xx	51 04 0xx	51 14 0xx	84
19	40	70	7	90	M6	65 54 019	265 23 096	65 59 401	59 04 0xx	59 14 0xx	57 04 0xx	57 14 0xx	51 04 0xx	51 14 0xx	78
19	40	95	7	115	M8	65 54 019		65 59 401	59 04 0xx	59 14 0xx	57 04 0xx	57 14 0xx	51 04 0xx	51 14 0xx	70
19	40	95	7	130	M8	65 54 019		65 59 403	59 04 0xx	59 14 0xx	57 04 0xx	57 14 0xx	51 04 0xx	51 14 0xx	70
19	40	110	7	130	M8	65 54 019		65 59 402	59 04 0xx	59 14 0xx	57 04 0xx	57 14 0xx	51 04 0xx	51 14 0xx	75
19	40	110	7	145	M8	65 54 019		65 59 410	59 04 0xx	59 14 0xx	57 04 0xx	57 14 0xx	51 04 0xx	51 14 0xx	70
19	40	130	7	165	M10	65 54 019		65 59 407	59 04 0xx	59 14 0xx	57 04 0xx	57 14 0xx	51 04 0xx	51 14 0xx	75
19	46	130	7	165	M10	65 54 019		65 59 407	59 04 0xx	59 14 0xx	57 04 0xx	57 14 0xx	51 04 0xx	51 14 0xx	75
19	55	95	7	115	M8	65 54 019	265 23 104	65 59 401	59 04 0xx	59 14 0xx	57 04 0xx	57 14 0xx	51 04 0xx	51 14 0xx	85
19	55	110	7	145	M8	65 54 019		65 59 411	59 04 0xx	59 14 0xx	57 04 0xx	57 14 0xx	51 04 0xx	51 14 0xx	81
19	58	110	7	145	M8	65 54 019		65 59 411	59 04 0xx	59 14 0xx	57 04 0xx	57 14 0xx	51 04 0xx	51 14 0xx	81
22	53.5	130	7	165	M10	65 54 022		65 59 409	59 04 0xx	59 14 0xx	57 04 0xx	57 14 0xx	51 04 0xx	51 14 0xx	95
22	55	110	7	145	M8	65 54 022		65 59 411	59 04 0xx	59 14 0xx	57 04 0xx	57 14 0xx	51 04 0xx	51 14 0xx	92
22	55	114.3	7	200	M12	65 54 022		65 59 414	59 04 0xx	59 14 0xx	57 04 0xx	57 14 0xx	51 04 0xx	51 14 0xx	88
22	58	110	7	145	M8	65 54 022		65 59 411	59 04 0xx	59 14 0xx	57 04 0xx	57 14 0xx	51 04 0xx	51 14 0xx	81
24	50	95	3.5	115	M8	65 54 024	265 24 091	65 59 401	59 04 0xx	59 14 0xx	57 04 0xx	57 14 0xx	51 04 0xx	51 14 0xx	77
24	55	110	7	145	M8	65 54 024		65 59 411	59 04 0xx	59 14 0xx	57 04 0xx	57 14 0xx	51 04 0xx	51 14 0xx	81
24	58	110	7	145	M8	65 54 024		65 59 415	59 04 0xx	59 14 0xx	57 04 0xx	57 14 0xx	51 04 0xx	51 14 0xx	86
28	60	130	7	165	M10	65 54 028		65 59 409	59 04 0xx	59 14 0xx	57 04 0xx	57 14 0xx	51 04 0xx	51 14 0xx	95
28	58	130	7	165	M10	65 54 028		65 59 409	59 04 0xx	59 14 0xx	57 04 0xx	57 14 0xx	51 04 0xx	51 14 0xx	95
28	55	114.3	7	200	M12	65 54 028		65 59 414	59 04 0xx	59 14 0xx	57 04 0xx	57 14 0xx	51 04 0xx	51 14 0xx	88
28	55	110	5	145	M8	65 54 028		65 59 411	59 04 0xx	59 14 0xx	57 04 0xx	57 14 0xx	51 04 0xx	51 14 0xx	78.2
32	50	130	7	165	M10	65 54 032		65 59 409	59 04 0xx	59 14 0xx	57 04 0xx	57 14 0xx	51 04 0xx	51 14 0xx	95
32	58	130	7	165	M10	65 54 032		65 59 409	59 04 0xx	59 14 0xx	57 04 0xx	57 14 0xx	51 04 0xx	51 14 0xx	95
32	58	130	4	215	M12	65 44 932	265 25 099	65 59 406	59 04 0xx	59 14 0xx	57 04 0xx	57 14 0xx	51 04 0xx	51 14 0xx	*
32	60	130	4	215	M12	65 44 932	265 25 099	65 59 406	59 04 0xx	59 14 0xx	57 04 0xx	57 14 0xx	51 04 0xx	51 14 0xx	*
35	79	114.3	7	200	M12	65 54 035		65 59 412	59 04 0xx	59 14 0xx	57 04 0xx	57 14 0xx	51 04 0xx	51 14 0xx	102
35	80	114.3	7	200	M12	65 54 035		65 59 412	59 04 0xx	59 14 0xx	57 04 0xx	57 14 0xx	51 04 0xx	51 14 0xx	102





ATLANTA

Servo-Motor Mounting Guide for E, B and BG Servo-Worm Gear Units

The pairing of servo-motors to servo-worm gear units only considers the servo shaft and flange dimensions; the servo-motor performance with the gear units must also be checked, as well as the individual application requirements.

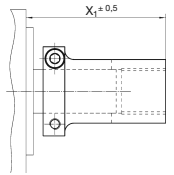

* Coupling to stop

Center Distance 80

Motor Sizes						Gearbox									
Shaft-Ø	Shaft Length	Pilot-Ø	Max. Length of Pilot	Bolt Circle	Fixing Srew	Coupling	Add. Flange	Motor Flange	E Servo Gearbox		B Servo Gearbox		BG Servo Gearbox		Dimen. for coupl. x1
									Key Way	Clamp Connection	Key Way	Clamp Connection	Key Way	Clamp Connection	
16	40	110	7	145	M8	65 55 016		65 59 508	59 05 0xx	59 15 0xx	57 05 0xx	57 15 0xx	51 05 0xx	51 15 0xx	80
19	40	80	4	100	M6	65 55 019	265 25 094	65 59 501	59 05 0xx	59 15 0xx	57 05 0xx	57 15 0xx	51 05 0xx	51 15 0xx	90
19	40	95	5	115	M8	581 20 002	265 25 092	65 59 501	59 05 0xx	59 15 0xx	57 05 0xx	57 15 0xx	51 05 0xx	51 15 0xx	*
19	40	95	5	130	M8	581 20 002	265 25 093	65 59 501	59 05 0xx	59 15 0xx	57 05 0xx	57 15 0xx	51 05 0xx	51 15 0xx	*
19	40	110	4	130	M8	65 55 019	265 25 090	65 59 501	59 05 0xx	59 15 0xx	57 05 0xx	57 15 0xx	51 05 0xx	51 15 0xx	89
19	40	110	7	145	M8	65 55 019		65 59 508	59 05 0xx	59 15 0xx	57 05 0xx	57 15 0xx	51 05 0xx	51 15 0xx	82
19	40	130	7	165	M10	65 55 019		65 59 507	59 05 0xx	59 15 0xx	57 05 0xx	57 15 0xx	51 05 0xx	51 15 0xx	85
19	40	130	7	165	M10	65 55 019		65 59 502	59 05 0xx	59 15 0xx	57 05 0xx	57 15 0xx	51 05 0xx	51 15 0xx	84
19	46	130	7	165	M10	581 20 002		65 59 507	59 05 0xx	59 15 0xx	57 05 0xx	57 15 0xx	51 05 0xx	51 15 0xx	95
19	55	80	7	100	M6	65 55 019	265 26 080	65 59 501	59 05 0xx	59 15 0xx	57 05 0xx	57 15 0xx	51 05 0xx	51 15 0xx	97.5
19	55	95	7	115	M8	65 55 019	265 25 092	65 59 501	59 05 0xx	59 15 0xx	57 05 0xx	57 15 0xx	51 05 0xx	51 15 0xx	80
19	55	110	7	145	M8	65 55 019		65 59 509	59 05 0xx	59 15 0xx	57 05 0xx	57 15 0xx	51 05 0xx	51 15 0xx	100
19	58	110	7	145	M8	65 55 019		65 59 509	59 05 0xx	59 15 0xx	57 05 0xx	57 15 0xx	51 05 0xx	51 15 0xx	100
22	53.5	130	4	165	M10	65 55 022	265 25 097	65 59 501	59 05 0xx	59 15 0xx	57 05 0xx	57 15 0xx	51 05 0xx	51 15 0xx	103.5
22	55	110	3	145	M8	502 27 047	265 25 081	65 59 505	59 05 0xx	59 15 0xx	57 05 0xx	57 15 0xx	51 05 0xx	51 15 0xx	117
22	55	110	7	145	M8	65 55 022		65 59 509	59 05 0xx	59 15 0xx	57 05 0xx	57 15 0xx	51 05 0xx	51 15 0xx	100
22	55	114.3	7	200	M12	65 55 022		65 59 512	59 05 0xx	59 15 0xx	57 05 0xx	57 15 0xx	51 05 0xx	51 15 0xx	97.5
22	58	110	7	145	M8	65 55 022		65 59 509	59 05 0xx	59 15 0xx	57 05 0xx	57 15 0xx	51 05 0xx	51 15 0xx	100
24	40	110	7	165	M10	65 55 024		65 59 501	59 05 0xx	59 15 0xx	57 05 0xx	57 15 0xx	51 05 0xx	51 15 0xx	77.5
24	58	110	7	145	M8	65 55 024		65 59 509	59 05 0xx	59 15 0xx	57 05 0xx	57 15 0xx	51 05 0xx	51 15 0xx	100
28	55	110	7	145	M8	65 55 028		65 59 509	59 05 0xx	59 15 0xx	57 05 0xx	57 15 0xx	51 05 0xx	51 15 0xx	82.5
28	55	114.3	7	200	M12	65 55 028		65 59 512	59 05 0xx	59 15 0xx	57 05 0xx	57 15 0xx	51 05 0xx	51 15 0xx	97.5
28	58	130	7	165	M10	65 55 028		65 59 507	59 05 0xx	59 15 0xx	57 05 0xx	57 15 0xx	51 05 0xx	51 15 0xx	104
28	58	180	7	215	M12	65 55 028		65 59 505	59 05 0xx	59 15 0xx	57 05 0xx	57 15 0xx	51 05 0xx	51 15 0xx	104
28	60	130	7	165	M10	65 55 028		65 59 507	59 05 0xx	59 15 0xx	57 05 0xx	57 15 0xx	51 05 0xx	51 15 0xx	105
28	60	180	7	215	M12	65 55 028		65 59 505	59 05 0xx	59 15 0xx	57 05 0xx	57 15 0xx	51 05 0xx	51 15 0xx	104
32	50	130	7	165	M10	65 46 932		65 59 507	59 05 0xx	59 15 0xx	57 05 0xx	57 15 0xx	51 05 0xx	51 15 0xx	*
32	58	130	7	165	M10	65 46 932		65 59 507	59 05 0xx	59 15 0xx	57 05 0xx	57 15 0xx	51 05 0xx	51 15 0xx	*
32	58	130	7	215	M12	65 55 032		65 59 506	59 05 0xx	59 15 0xx	57 05 0xx	57 15 0xx	51 05 0xx	51 15 0xx	104
32	58	180	7	215	M12	65 55 032		65 59 505	59 05 0xx	59 15 0xx	57 05 0xx	57 15 0xx	51 05 0xx	51 15 0xx	104
32	60	130	7	215	M12	65 55 032		65 59 506	59 05 0xx	59 15 0xx	57 05 0xx	57 15 0xx	51 05 0xx	51 15 0xx	104
32	60	180	7	215	M12	65 55 032		65 59 505	59 05 0xx	59 15 0xx	57 05 0xx	57 15 0xx	51 05 0xx	51 15 0xx	104
35	79 - 80	114.3	7	200	M12	65 55 035		65 59 510	59 05 0xx	59 15 0xx	57 05 0xx	57 15 0xx	51 05 0xx	51 15 0xx	118
38	80	180	6	215	M12	65 55 038		65 59 504	59 05 0xx	59 15 0xx	57 05 0xx	57 15 0xx	51 05 0xx	51 15 0xx	119
42	110	250	5	300	M16	505 33 019	265 27 025	65 59 503	59 05 0xx	59 15 0xx	57 05 0xx	57 15 0xx	51 05 0xx	51 15 0xx	*



ATLANTA

Servo-Motor Mounting Guide for E, B and BG Servo-Worm Gear Units

The pairing of servo-motors to servo-worm gear units only considers the servo shaft and flange dimensions; the servo-motor performance with the gear units must also be checked, as well as the individual application requirements.

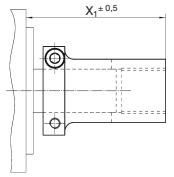

* Coupling to stop

Center Distance 100

Motor Sizes						Gearbox							Dimen. for coupl. x1		
Shaft-Ø	Shaft Length	Pilot-Ø	Max. Length of Pilot	Bolt Circle	Fixing Srew	Coupling	Add. Flange	Motor Flange	E Servo Gearbox		B Servo Gearbox			BG Servo Gearbox	
									Key Way	Clamp Connection	Key Way	Clamp Connection	Key Way	Clamp Connection	
24	40	110	7	165	M10	65 55 024		65 59 501	59 06 0xx	59 16 0xx	57 06 0xx	57 16 0xx			84
24	50	110	7	165	M10	65 55 024		65 59 501	59 06 0xx	59 16 0xx	57 06 0xx	57 16 0xx			84
24	50	130	7	165	M10	65 55 024		65 59 502	59 06 0xx	59 16 0xx	57 06 0xx	57 16 0xx			84
28	42	180	7	215	M12	65 55 028		65 59 505	59 06 0xx	59 16 0xx	57 06 0xx	57 16 0xx			94
28	58	130	7	165	M10	65 55 028		65 59 507	59 06 0xx	59 16 0xx	57 06 0xx	57 16 0xx			104
28	58	180	7	215	M12	65 55 028		65 59 505	59 06 0xx	59 16 0xx	57 06 0xx	57 16 0xx			94
28	60	130	7	165	M10	65 55 028		65 59 507	59 06 0xx	59 16 0xx	57 06 0xx	57 16 0xx			104
28	60	180	7	215	M12	65 55 028		65 59 505	59 06 0xx	59 16 0xx	57 06 0xx	57 16 0xx			94
32	50	130	7	165	M10	65 55 032		65 59 502	59 06 0xx	59 16 0xx	57 06 0xx	57 16 0xx			84
32	58	130	7	165	M10	65 55 032		65 59 507	59 06 0xx	59 16 0xx	57 06 0xx	57 16 0xx			102
32	58	180	7	215	M12	65 55 032		65 59 505	59 06 0xx	59 16 0xx	57 06 0xx	57 16 0xx			104
32	60	130	7	215	M10	65 55 032	265 25 099	65 59 501	59 06 0xx	59 16 0xx	57 06 0xx	57 16 0xx			100
32	60	180	7	215	M12	65 55 032		65 59 505	59 06 0xx	59 16 0xx	57 06 0xx	57 16 0xx			104
35	79 - 80	114.3	7	200	M12	65 55 035		65 59 510	59 06 0xx	59 16 0xx	57 06 0xx	57 16 0xx			117
38	80	180	6	215	M12	65 55 038		65 59 504	59 06 0xx	59 16 0xx	57 06 0xx	57 16 0xx			115





ATLANTA Rack and Pinions

The Widest Range of High-Quality Racks on the World.

The new quality classes of ATLANTA racks with hardened & ground teeth, reduce frictional losses and create high-efficiency rack & pinion drives at a level never achieved before.

With a complete ATLANTA servo gearbox family, ATLANTA can now offer a complete rack & pinion drive system family. This makes it possible to supply, from one source, complete rack & pinion drive systems perfectly tailored to meet the customers requirements including gearbox, pinion and rack.



TR Pinion & Rack

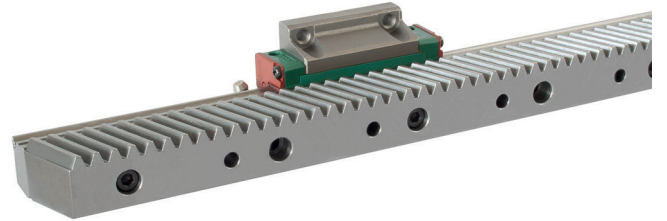

Integrated Rack



Sheet metal processing machine with full automatic loading



5 Axis Machine Tool



UHPR – Ultra High Precision Rack

Quality 3
Quality 5

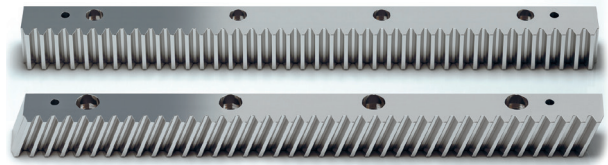

HPR – High Precision Rack

Quality 6
Quality 7

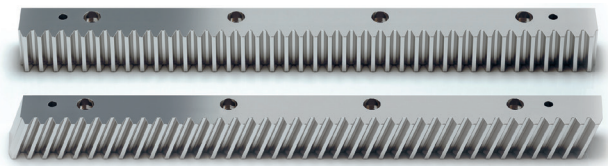

PR – Precision Rack

Quality 8

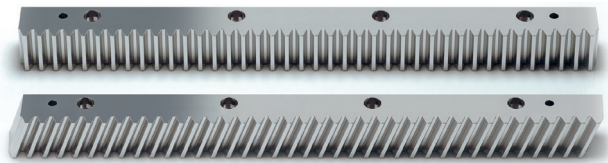

BR – Basic Rack

Quality 9
Quality 10

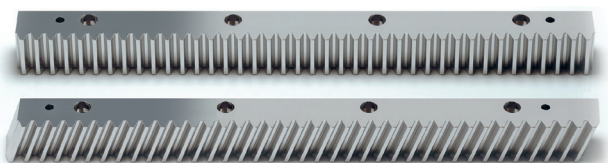

Ritzel Pinions

Quality 5 – 8



All the racks and pinions here listed have a pressure angle 20°



Advantages of Using Long, Ground Racks from ATLANTA

For mounted racks, the obtained accuracy and required installation time are important. With ATLANTA ground racks with lengths of 1,500 mm and 2,000 mm, the total pitch error per meter is reduced dramatically. Thus, the pitch error of the entire axis is correspondingly lower. By using long racks, the number of rack joints is reduced, which improves the accuracy of the entire axis and significantly reduces the installation time at the same time.

Ground racks have the advantage that the complete rack is more precise, the meshing takes place evenly and the pinion bearing stress is reduced unlike a milled tooth. The ground rack drives have lower friction which increase energy efficiency.

Example:

Module: 4
Quality 6

Assembly length: 6 meter mounted with companion rack for assembly i.e. $Q_{joint} = 25 \mu m$

Time: Number of screws $\times t_{screw}$ + number of joints $\times t_{joint}$ + number of pins $\times t_{pin}$

Accuracy: $GT_f: 44 \mu m$ **Maximum pitch error:** $3 \times 44 \mu m + 2 \times 25 \mu m = 182 \mu m$

Time: 2 meter racks: Number of screws: $3 \times 16 = 48$ screws Number of joints: 2 Number of pins: 0



Accuracy: $GT_f: 34 \mu m (1000mm)$ **Maximum pitch error:** $6 \times 34 \mu m + 5 \times 25 \mu m = 329 \mu m$

Time: 1 meter racks: Number of screws: $6 \times 8 = 48$ screws Number of joints: 5 Number of pins: 0

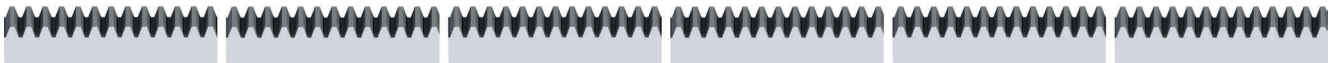

Accuracy: $GT_f: 26 \mu m$ **Maximum pitch error:** $12 \times 26 \mu m + 11 \times 25 \mu m = 587 \mu m$

Time: 0.5 meter racks: Number of screws: $12 \times 4 = 48$ screws Number of joints: 11 Number of pins: $12 \times 2 = 24$

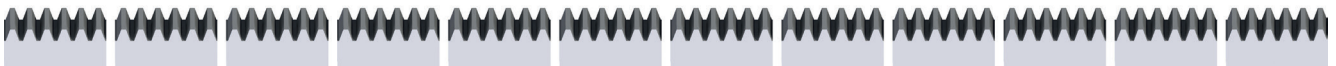



Class	ATLANTA Quality	Module	Total Pitch Error ¹⁾ (± μm/m)	Tooth Thickness Tolerance (μm)	Max. Length (mm)	Max. Feed Force per Pinion Contact ²⁾ (kN)	Applications (Examples)	
UHPR Ultra High Precision Rack	3	5	12	-13	1000	76.5	High Precision Machine Tools with Electrical Preload	
		6	12	-13	1000	109.0		
		8	12	-13	960	191.0		
		10	12	-13	1000	287.5		
		12	12	-13	1000	409.0		
HPR High Precision Rack	5	3	26	-15	1000	31.0	Machine Tools, Lifting Axis, Multiple Pinion Contact	
		4	26	-15	1000	60.0		
		5	26	-15	1000	92.0		
	6	2	34	-20	2000	19.5	Wood, Plastic, Composite, Aluminium Working Machines	
		3	34	-20	2000	31.0		
		4	34	-20	2000	60.0		
		1.5	2	34	-20	1000	9.0	Machine Tools, Integratable Racks, Water Cutting Machines, Tube Bending Systems, Plasma Cutting Machines
			3	34	-20	2000	15.5	
			4	34	-20	2000	28.5	
			5	34	-20	2000	51.5	
			6	34	-20	2000	76.0	
			8	34	-20	1920	109.0	
7	2	52	-36	2000	15.5	Woodworking Machines, Linear Axis with High Requirement for a Smooth Running		
	3	52	-36	2000	28.5			
	4	52	-36	2000	51.5			
	5	52	-36	2000	76.0			
	6	52	-36	2000	109.0			
8	2	60	-59	1000	13.5	Portals, Handling Linear Axis		
	3	60	-59	1000	24.5			
	4	60	-59	1000	44.0			
	5	60	-59	1000	64.5			
	8	2	100	-110	2000		8.0	Linear Axis
3		100	-110	2000	14.0			
4		100	-110	2000	27.0			
BR Basic Rack	9	1.5	150	-110	2000	1.5	Linear Axis with Low Load Feed Units for Adjustment	
		2	150	-110	2000	4.0		
		3	150	-110	2000	7.0		
		4	150	-110	2000	13.5		
		5	150	-110	2000	16.0		
		6	150	-110	2000	23.0		
		8	150	-110	1920	41.5		
	10	1.5	200	-110	1000	3.5	Lifting Axis, Handling, Welding Robots	
		2	200	-110	2000	9.5		
		3	200	-110	2000	17.5		
4	200	-110	2000	32.0				
	5	200	-110	2000	49.0			
	6	200	-110	2000	67.5			
	8	200	-110	1920	118.5			
	10	200	-110	1000	178.5			
12	200	-110	1000	252.5				







¹⁾ Values available for 1000 mm. Other total pitch errors for other length, see detailed description.

²⁾ Values are only valid for special steel according to ATLANTA-Standard.









When using the maximum capacity of the teeth, or multiple pinions in contact, the mounting screw loads must be checked separately! Please ask ATLANTA for advice!



Class	Series	Module	ATLANTA-Quality	Page
UHPR	48	5, 6, 8, 10, 12	3	ZA-4
	29	3, 4, 5, 6	5	ZA-5
HPR	29	2, 3, 4	6	ZA-6
	29	1.5, 2, 3, 4, 5, 6, 8, 10, 12	6	ZA-7
	29	2, 3, 4, 5, 6, 8, 10	7	ZA-8
PR	39	2, 3, 4, 5	8	ZA-9
	38	2, 3, 4	8	ZA-10
BR	47	1.5, 2, 3, 4, 5, 6, 8, 10	9	ZA-11
	39	1.5, 2, 3, 4, 5, 6, 8, 10, 12	10	ZA-12-13
	Selection and Load Tables			ZA-30-38
	Electronically Controlled Lubricators, Sliding-Type Lubricating Brushes and Hose-Connection Sets			ZE-2-6
	Felt Gear and Mounting Shaft			ZE-7-8
	Mounting			ZF-9

¹⁾ All our helical racks are right hand, except the companion racks, which are left hand!



	Series	Module	Heat-Treatment of Teeth	Tolerance of Teeth	Page
	78	2, 3, 4, 5, 6	Case-Hardened	≤ 5	ZA-14-18
	78 .. 5..	2, 3, 4, 5	Case-Hardened	5 e 24	ZA-19-22
	79	1.5, 2, 3, 4	Case-Hardened	5 e 24	ZA-23
	24	1.5, 2, 3, 4, 5, 6, 8, 10	Case-Hardened	7 e 25	ZA-24-26
	24	2, 3, 4, 5, 6, 8	Induction Hardened	6 e 25	ZA-27
	21 .. 5..	1.5, 2, 3, 4, 5, 6, 8, 10, 12	Soft	8 e 25	ZA-28-29
	Short Description TR-Pinion, Mounting Instructions				ZF-11-13
	Selection and Load Tables for Rack Drives				ZH-2-6
	Electronically Controlled Lubricators, Sliding-Type Lubricating Brushes and Hose-Connection Sets				ZE-2-6

¹⁾ All our helical pinions are left hand!





ATLANTA-Quality 3

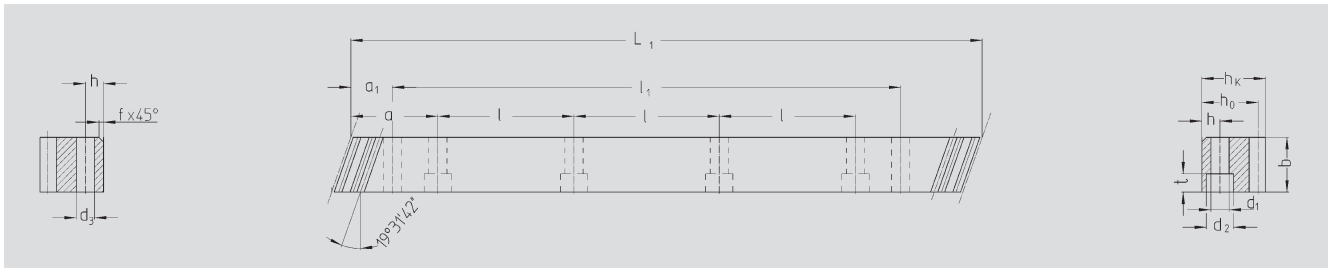

Order Code	Module	L ₁	N° of teeth	b ^{+0.4}	h _k	h ₀	f	a	l	N° of holes	h	d ₁	d ₂	t	a ₁	l ₁	d ₃	kg
48 50 105	5	1000.00	60	49	39	34	2.5	62.5	125	8	12	13.5	20	13	37.5	925	11.7	12.15
48 60 105	6	1000.00	50	59	49	43	2.5	62.5	125	8	16	17.5	26	17	37.5	925	15.7	18.10
48 80 105	8	960.00	36	79	79	71	2.5	60.0	120	8	25	22.0	33	21	120.0	720	19.7	42.50
48 10 105	10	1000.00	30	99	99	89	2.5	62.5	125	8	32	33.0	48	32	125.0	750	19.7	68.70
48 12 105	12	1000.00	25	120	120	108	2.5	40.0	125	8	40	39.0	58	38	102.5	750	19.7	111.00

Total pitch error

$$GT_f/1000 \leq 0.012 \text{ mm}$$

- Teeth hardened with the ATLANTA high performance hardening process and ground
- Heat-treatable steel according to ATLANTA-Standard
- Ground on all sides after hardening
- Signed with effective total pitch error (20°C)

Inspection measurement data available as an option.

To achieve precision rack joints, we recommend our patented rack assembly kit, see page ZF-4.

For lubrication of racks & pinions, we recommend our automatic lubrication systems, see page ZE-1.

For the calculation and selection of the rack & pinion drive, see page ZD-1.

Screws for rack mounting, see page ZF-3.





ATLANTA-Quality 5

StrongLine

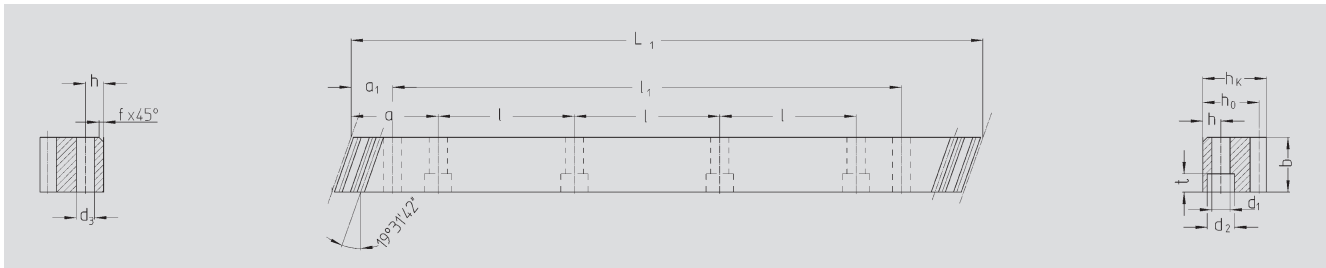

Order Code	Module	L ₁	N° of teeth	b ^{+0.4}	h _k	h ₀	f	a	l	N° of holes	h	d ₁	d ₂	t	a ₁	l ₁	d ₃	
29 35 100	3	1000.00	100	29	29	26	2.0	62.5	125	8	10	12	17.5	11	27.5	945	11.7	5.9
29 45 100	4	1000.00	75	39	39	35	2.0	62.5	125	8	13	16	23.0	15	30.0	940	15.7	10.7
29 55 100	5	1000.00	60	49	49	44	2.5	62.5	125	8	15	18	26.0	17	34.5	931	15.7	16.3
29 65 100	6	1000.00	50	59	59	53	2.5	62.5	125	8	20	22	33.0	21	97.5	805	19.7	24.5

Total pitch error $GT_f/1000 \leq 0.026 \text{ mm}$

- Teeth case hardened and ground
- Case hardening steel according to ATLANTA-Standard
- Ground on all sides after hardening
- Signed with effective total pitch error (20°C)

Inspection measurement data available as an option.

Mounting racks, see page ZF-2.

To achieve precision rack joints, we recommend our patented rack assembly kit, see page ZF-4.



For lubrication of racks & pinions, we recommend our automatic lubrication systems, see page ZE-1.

For the calculation and selection of the rack & pinion drive, see page ZD-1.

Screws for rack mounting, see page ZF-3.



ATLANTA-Quality 6

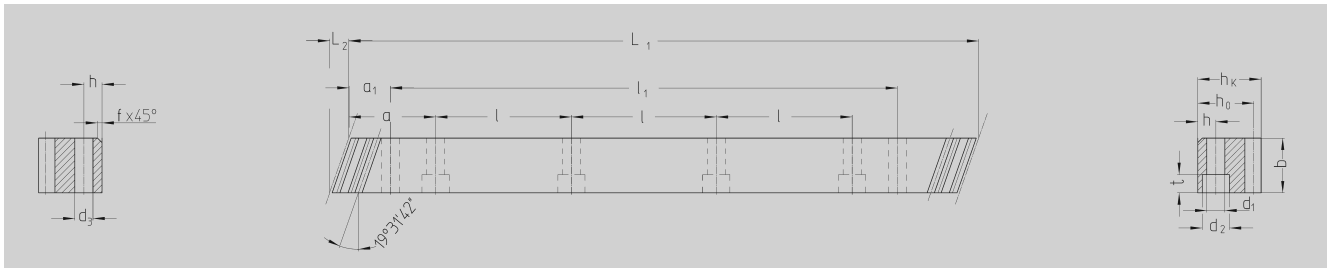

Order Code	Module	L ₁	L ₂	N° of Teeth	b	h _k	h ₀	f	a	l	N° of Holes	h	d ₁	d ₂	t	a ₁	l ₁	d ₃	kg
29 20 050 ²⁾	2	500.00	8.5	75	24	24	22	2	62.5	125	4	8	7	11	7	31.7	436.6	5.7	2.10
29 21 050	2	500.00	8.5	75	24	24	22	2	62.5	125	4	without Mounting Holes							2.10
29 20 100	2	1000.00	8.5	150	24	24	22	2	62.5	125	8	8	7	11	7	31.7	936.6	5.7	4.10
29 21 100	2	1000.00	8.5	150	24	24	22	2	62.5	125	8	without Mounting Holes							4.10
29 20 150	2	1500.00	8.5	225	24	24	22	2	62.5	125	12	8	7	11	7	31.7	1436.6	5.7	6.15
29 21 150	2	1500.00	8.5	225	24	24	22	2	62.5	125	12	without Mounting Holes							6.15
29 20 200	2	2000.00	8.5	300	24	24	22	2	62.5	125	16	8	7	11	7	31.7	1936.6	5.7	8.20
29 21 200	2	2000.00	8.5	300	24	24	22	2	62.5	125	16	without Mounting Holes							8.20
29 30 050 ²⁾	3	500.00	10.3	50	29	29	26	2	62.5	125	4	9	10	15	9	35.0	430.0	7.7	2.90
29 31 050	3	500.00	10.3	50	29	29	26	2	62.5	125	4	without Mounting Holes							2.90
29 30 100	3	1000.00	10.3	100	29	29	26	2	62.5	125	8	9	10	15	9	35.0	930.0	7.7	5.90
29 31 100	3	1000.00	10.3	100	29	29	26	2	62.5	125	8	without Mounting Holes							5.90
29 30 150	3	1500.00	10.3	150	29	29	26	2	62.5	125	12	9	10	15	9	35.0	1430.0	7.7	8.85
29 31 150	3	1500.00	10.3	150	29	29	26	2	62.5	125	12	without Mounting Holes							8.85
29 30 200	3	2000.00	10.3	200	29	29	26	2	62.5	125	16	9	10	15	9	35.0	1930.0	7.7	11.80
29 31 200	3	2000.00	10.3	200	29	29	26	2	62.5	125	16	without Mounting Holes							11.80
29 40 050 ¹⁾²⁾	4	506.67	13.8	38	39	39	35	2	62.5	125	4	12	10	15	9	33.3	433.0	7.7	5.40
29 41 050	4	506.67	13.8	38	39	39	35	2	62.5	125	4	without Mounting Holes							5.40
29 40 100 ²⁾	4	1000.00	13.8	75	39	39	35	2	62.5	125	8	12	10	15	9	33.3	933.4	7.7	10.70
29 41 100	4	1000.00	13.8	75	39	39	35	2	62.5	125	8	without Mounting Holes							10.70
29 42 100	4	1000.00	13.8	75	39	39	35	2	62.5	125	8	12	14	20	13	33.3	933.4	11.7	10.70
29 41 150	4	1506.67	13.8	113	39	39	35	2	62.5	125	12	without Mounting Holes							16.00
29 42 150 ¹⁾	4	1506.67	13.8	113	39	39	35	2	62.5	125	12	12	14	20	13	33.3	1433.4	11.7	16.00
29 41 200	4	2000.00	13.8	150	39	39	35	2	62.5	125	16	without Mounting Holes							21.40
29 42 200	4	2000.00	13.8	150	39	39	35	2	62.5	125	16	12	14	20	13	33.3	1933.4	11.7	21.40

- 1) This racks should be used for continuous linking only with the left side (see sketch).
- 2) The screw joint limits the feed force.

Total pitch error:

$GT_f / 500 \leq 0.026 \text{ mm}$

$GT_f / 1000 \leq 0.034 \text{ mm}$

$GT_f / 1500 \leq 0.041 \text{ mm} (\leq 0.027 / 1000 \text{ mm})$

$GT_f / 2000 \leq 0.044 \text{ mm} (\leq 0.022 / 1000 \text{ mm})$

- Teeth induction-hardened and ground
- Material 16MnCr5, carburized
- Ground on all sides after hardening

Highlighted items will become obsolete in the future. Please check with the factory for delivery information.

Mounting racks, see page ZF-2.

To achieve precision rack joints, we recommend our patented rack assembly kit, see page ZF-4.

For lubrication of racks & pinions, we recommend our automatic lubrication systems, see page ZE-1.

For the calculation and selection of the rack & pinion drive, see page ZD-1.

Screws for rack mounting, see page ZF-3.



ATLANTA-Quality 6

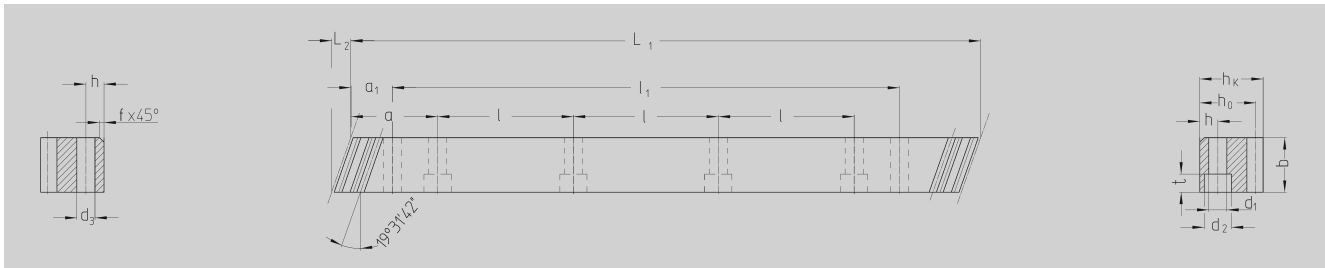

Order Code	Module	L ₁	L ₂	N° of Teeth	b	h _k	h ₀	f	a	l	N° of Holes	h	d ₁	d ₂	t	a ₁	l ₁	d ₃	kg	
29 15 055 ²⁾	1.5	500.00	6.74	100	19	19	17.5	2	62.5	125	4	8	7	11	7	31.7	436.6	5.7	1.30	
29 16 055	1.5	500.00	6.74	100	19	19	17.5	2	62.5	125	4	without Mounting Holes								1.30
29 15 105	1.5	1000.00	6.74	200	19	19	17.5	2	62.5	125	8	8	7	11	7	31.7	936.6	5.7	2.60	
29 16 105	1.5	1000.00	6.74	200	19	19	17.5	2	without Mounting Holes								2.60			
29 20 105	2	1000.00	8.50	150	24	24	22	2	62.5	125	8	8	7	11	7	31.7	936.6	5.7	4.10	
29 21 105	2	1000.00	8.50	150	24	24	22	2	without Mounting Holes								4.10			
29 20 155	2	1500.00	8.50	225	24	24	22	2	62.5	125	12	8	7	11	7	31.7	1436.6	5.7	6.15	
29 21 155	2	1500.00	8.50	225	24	24	22	2	without Mounting Holes								6.15			
29 20 205	2	2000.00	8.50	300	24	24	22	2	62.5	125	16	8	7	11	7	31.7	1936.6	5.7	8.20	
29 21 205	2	2000.00	8.50	300	24	24	22	2	without Mounting Holes								8.20			
29 30 105	3	1000.00	10.30	100	29	29	26	2	62.5	125	8	9	10	15	9	35.0	930.0	7.7	5.90	
29 31 105	3	1000.00	10.30	100	29	29	26	2	without Mounting Holes								5.90			
29 30 155	3	1500.00	10.30	150	29	29	26	2	62.5	125	12	9	10	15	9	35.0	1430.0	7.7	8.85	
29 31 155	3	1500.00	10.30	150	29	29	26	2	without Mounting Holes								8.85			
29 30 205	3	2000.00	10.30	200	29	29	26	2	62.5	125	16	9	10	15	9	35.0	1930.0	7.7	11.80	
29 31 205	3	2000.00	10.30	200	29	29	26	2	without Mounting Holes								11.80			
29 40 105 ²⁾	4	1000.00	13.80	75	39	39	35	2	62.5	125	8	12	10	15	9	33.3	933.4	7.7	10.70	
29 41 105	4	1000.00	13.80	75	39	39	35	2	without Mounting Holes								10.70			
29 42 105	4	1000.00	13.80	75	39	39	35	2	62.5	125	8	12	14	20	13	33.3	939.4	11.7	13.00	
29 42 155 ¹⁾	4	1506.67	13.80	113	39	39	35	2	62.5	125	12	12	14	20	13	33.3	1433.4	11.7	19.50	
29 40 205	4	2000.00	13.80	150	39	39	35	2	62.5	125	16	12	10	15	9	33.3	1933.4	7.7	21.40	
29 41 205	4	2000.00	13.80	150	39	39	35	2	without Mounting Holes								21.40			
29 42 205	4	2000.00	13.80	150	39	39	35	2	62.5	125	16	12	14	20	13	33.3	1933.4	11.7	21.40	
29 50 055 ²⁾	5	500.00	17.40	30	49	39	34	2.5	62.5	125	4	12	14	20	13	37.5	425.0	11.7	6.50	
29 51 055	5	500.00	17.40	30	49	39	34	2.5	without Mounting Holes								6.50			
29 50 105	5	1000.00	17.40	60	49	39	34	2.5	62.5	125	8	12	14	20	13	37.5	925.0	11.7	13.00	
29 51 105	5	1000.00	17.40	60	49	39	34	2.5	without Mounting Holes								13.00			
29 50 155	5	1500.00	17.40	90	49	39	34	2.5	62.5	125	12	12	14	20	13	37.5	1425.0	11.7	19.50	
29 51 155	5	1500.00	17.40	90	49	39	34	2.5	without Mounting Holes								19.50			
29 50 205	5	2000.00	17.40	120	49	39	34	2.5	62.5	125	16	12	14	20	13	37.5	1925.0	11.7	26.00	
29 51 205	5	2000.00	17.40	120	49	39	34	2.5	without Mounting Holes								26.00			
29 60 055 ²⁾	6	500.00	20.90	25	59	49	43	2.5	62.5	125	4	16	18	26	17	37.5	425.0	15.7	9.90	
29 61 055	6	500.00	20.90	25	59	49	43	2.5	without Mounting Holes								9.90			
29 60 105	6	1000.00	20.90	50	59	49	43	2.5	62.5	125	8	16	18	26	17	37.5	925.0	15.7	18.10	
29 61 105	6	1000.00	20.90	50	59	49	43	2.5	without Mounting Holes								18.10			
29 60 155	6	1500.00	20.90	75	59	49	43	2.5	62.5	125	12	16	18	26	17	37.5	1425.0	15.7	27.10	
29 61 155	6	1500.00	20.90	75	59	49	43	2.5	without Mounting Holes								27.10			
29 60 205	6	2000.00	20.90	100	59	49	43	2.5	62.5	125	16	16	18	26	17	37.5	1925.0	15.7	36.20	
29 61 205	6	2000.00	20.90	100	59	49	43	2.5	without Mounting Holes								36.20			
29 80 055 ²⁾	8	480.00	28.00	18	79	79	71	2.5	60.0	120	4	25	22	33	21	120.0	240.0	19.7	21.00	
29 81 055	8	480.00	28.00	18	79	79	71	2.5	without Mounting Holes								21.00			
29 80 105	8	960.00	28.00	36	79	79	71	2.5	60.0	120	8	25	22	33	21	120.0	720.0	19.7	42.50	
29 81 105	8	960.00	28.00	36	79	79	71	2.5	without Mounting Holes								42.50			
29 80 205	8	1920.00	28.00	72	79	79	71	2.5	60.0	120	16	25	22	33	21	120.0	1680.0	19.7	85.00	
29 81 205	8	1920.00	28.00	72	79	79	71	2.5	without Mounting Holes								85.00			
29 10 105	10	1000.00	35.11	30	99	99	89	2.5	62.5	125	8	32	33	48	32	125.0	750.0	19.7	68.72	
29 11 105	10	1000.00	35.11	30	99	99	89	2.5	without Mounting Holes								68.72			
29 10 155	10	1500.00	35.11	45	99	99	89	2.5	62.5	125	12	32	33	48	32	125	1250.0	19.7	103.00	
29 11 155	10	1500.00	35.11	45	99	99	89	2.5	without Mounting Holes								103.00			
29 12 105	12	1000.00	42.56	25	120	120	108	2.5	40.0	125	8	40	39	58	38	125.0	750.0	19.7	111.00	
29 13 105	12	1000.00	42.56	25	120	120	108	2.5	without Mounting Holes								111.00			



1) These racks should be used for continuous linking only with the left side (see sketch).
 2) The screw joint limits the feed force.

**Total pitch error: $GT_f / 500 \leq 0.026 \text{ mm}$, $GT_f / 1000 \leq 0.034 \text{ mm}$
 $GT_f / 1500 \leq 0.041 \text{ mm}$ ($\leq 0.027/1000 \text{ mm}$), $GT_f / 2000 \leq 0.044 \text{ mm}$ ($\leq 0.022/1000 \text{ mm}$)**

• Further information see next page.



ATLANTA-Quality 7

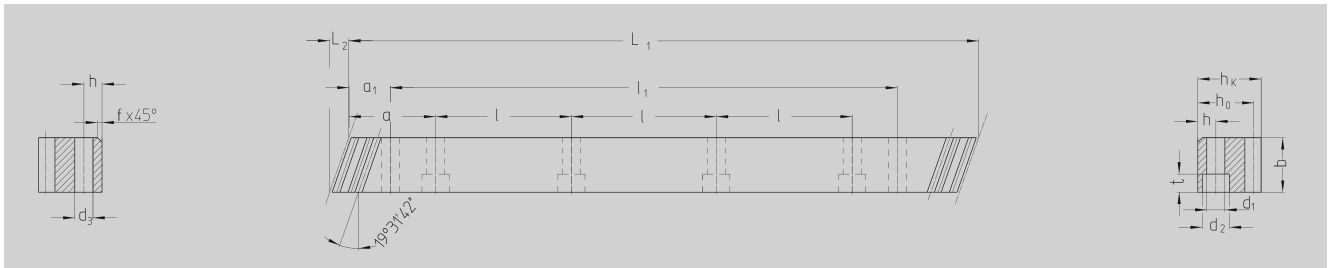

Order Code	Module	L ₁	L ₂	N° of Teeth	b	h _k	h ₀	f	a	l	N° of Holes	h	d ₁	d ₂	t	a ₁	l ₁	d ₃	kg
29 20 107	2	1000.00	8.5	150	24	24	22	2	62.5	125	8	8	7	11	7	31.7	936.6	5.7	4.10
29 20 157	2	1500.00	8.5	225	24	24	22	2	62.5	125	12	8	7	11	7	31.7	1436.6	5.7	6.15
29 20 207	2	2000.00	8.5	300	24	24	22	2	62.5	125	16	8	7	11	7	31.7	1936.6	5.7	8.20
29 30 107	3	1000.00	10.3	100	29	29	26	2	62.5	125	8	9	10	15	9	35.0	930.0	7.7	5.90
29 30 157	3	1500.00	10.3	150	29	29	26	2	62.5	125	12	9	10	15	9	35.0	1430.0	7.7	8.85
29 30 207	3	2000.00	10.3	200	29	29	26	2	62.5	125	16	9	10	15	9	35.0	1930.0	7.7	11.80
29 40 107	4	1000.00	13.8	75	39	39	35	2	62.5	125	8	12	14	20	13	33.3	933.4	11.7	10.70
29 40 157 ¹⁾	4	1506.67	13.8	113	39	39	35	2	62.5	125	12	12	14	20	13	33.3	1433.4	11.7	16.00
29 40 207	4	2000.00	13.8	150	39	39	35	2	62.5	125	16	12	14	20	13	33.3	1933.4	11.7	21.40
29 50 107	5	1000.00	17.4	60	49	39	34	2.5	62.5	125	8	12	14	20	13	37.5	925.0	11.7	13.00
29 50 157	5	1500.00	17.4	90	49	39	34	2.5	62.5	125	12	12	14	20	13	37.5	1425.0	11.7	19.50
29 50 207	5	2000.00	17.4	120	49	39	34	2.5	62.5	125	16	12	14	20	13	37.5	1925.0	11.7	26.00
29 60 107	6	1000.00	20.9	50	59	49	43	2.5	62.5	125	8	16	18	26	17	37.5	925.0	15.7	18.10
29 60 157	6	1500.00	20.9	75	59	49	43	2.5	62.5	125	12	16	18	26	17	37.5	1425.0	15.7	27.10
29 60 207	6	2000.00	20.9	100	59	49	43	2.5	62.5	125	16	16	18	26	17	37.5	1925.0	15.7	36.20
29 80 107	8	960.00	28.0	36	79	79	71	2.5	60.0	120	8	25	22	33	21	120.0	720.0	19.7	42.50
29 80 157	8	1440.00	28.0	54	79	79	71	2.5	60.0	120	12	25	22	33	21	120.0	1200.0	19.7	65.00
29 80 207	8	1920.00	28.0	72	79	79	71	2.5	60.0	120	16	25	22	33	21	120.0	1680.0	19.7	85.00
29 10 107	10	1000.00	35.11	30	99	99	89	2.5	62.5	125	8	32	33	48	32	125.0	750.0	19.7	68.72
29 10 157	10	1500.00	35.11	45	99	99	89	2.5	62.5	125	12	32	33	48	32	125.0	1425.0	19.7	104.00

1) These racks should be used for continuous linking only with the left side (see sketch).



Total pitch error:

- GT_f/1000 ≤ 0.052 mm
- GT_f/1500 ≤ 0.062 mm (≤ 0.041/1000 mm)
- GT_f/2000 ≤ 0.068 mm (≤ 0.034/1000 mm)

- Teeth induction-hardened and ground
- Material C45
- Ground on all sides after hardening

Mounting racks, see page ZF-2.

To achieve precision rack joints, we recommend our patented rack assembly kit, see page ZF-4.

For lubrication of racks & pinions, we recommend our automatic lubrication systems, see page ZE-1.

For the calculation and selection of the rack & pinion drive, see page ZD-1.

Screws for rack mounting, see page ZF-3.



ATLANTA-Quality 8

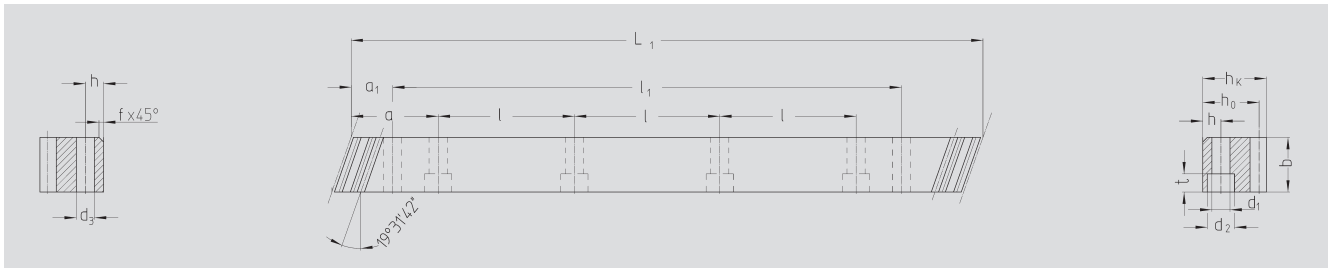

Order Code	Module	L ₁	N° of teeth	b ^{+0,4}	h _k	h ₀	f	a	l	N° of holes	h	d ₁	d ₂	t	a ₁	l ₁	d ₃	kg
39 20 108	2	1000.00	150	25	24	22	2	62.5	125	8	8	7	11	7	31.7	936.6	5.7	4.10
39 20 208	2	2000.00	300	25	24	22	2	62.5	125	16	8	7	11	7	31.7	1936.6	5.7	8.40
39 30 108	3	1000.00	100	30	29	26	2	62.5	125	8	9	10	15	9	35.0	930.0	7.7	5.90
39 30 208	3	2000.00	200	30	29	26	2	62.5	125	16	9	10	15	9	35.0	1930.0	7.7	12.00
39 40 108	4	1000.00	75	40	39	35	2	62.5	125	8	12	14	20	13	33.3	933.4	11.7	10.70
39 40 208	4	2000.00	150	40	39	35	2	62.5	125	16	12	14	20	13	33.3	1933.4	11.7	21.00
39 50 108	5	1000.00	60	50	39	34	2.5	62.5	125	8	12	14	20	13	37.5	925.0	11.7	13.00
39 50 208	5	2000.00	120	50	39	34	2.5	62.5	125	16	12	14	20	13	37.5	1925.0	11.7	26.00

**500 mm and other length on request.
Without bores on request.**

Total pitch error:

$$GT_f / 1000 \leq 0.060 \text{ mm}$$

$$GT_f / 2000 \leq 0.078 \text{ mm } (\leq 0.039 \text{ mm}/1000)$$

- Teeth hardened with the ATLANTA high performance hardening process and ground
- Heat-treatable, bright steel according to ATLANTA-Standard

Mounting racks, see page ZF-2.

To achieve precision rack joints, we recommend our patented rack assembly kit, see page ZF-4.

For lubrication of racks & pinions, we recommend our automatic lubrication systems, see page ZE-1.

For the calculation and selection of the rack & pinion drive, see page ZD-1.

Screws for rack mounting, see page ZF-3.





ATLANTA-Quality 8

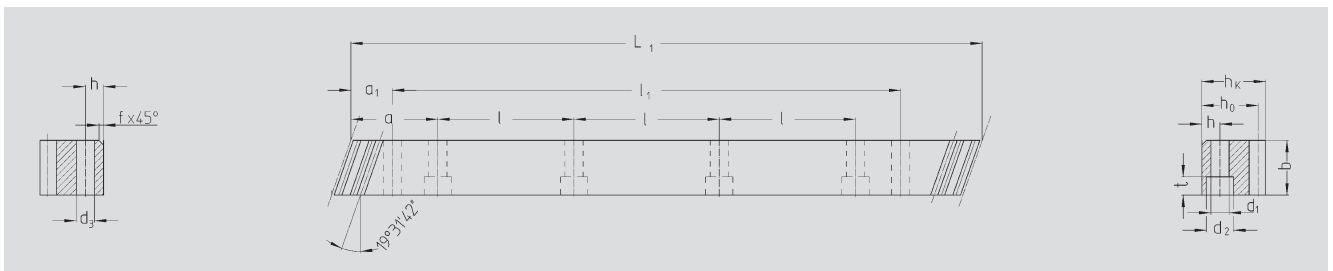

Order Code	Module	L ₁	N° of teeth	b _{0.5}	h _k	h ₀	f	a	l	N° of holes	h	d ₁	d ₂	t	a ₁	l ₁	d ₃	kg
38 21 100	2	1000.00	150	25	24	22	2	62.5	125	8	8	7	11	7	31.7	936.6	5.7	4.30
38 20 100	2	1000.00	150	25	24	22	2	without mounting holes										4.30
38 21 200	2	2000.00	300	25	24	22	2	62.5	125	16	8	7	11	7	31.7	1936.6	5.7	8.60
38 20 200	2	2000.00	300	25	24	22	2	without mounting holes										8.60
38 31 100	3	1000.00	100	30	29	26	2	62.5	125	8	9	10	15	9	35.0	930.0	7.7	6.10
38 30 100	3	1000.00	100	30	29	26	2	without mounting holes										6.10
38 31 200	3	2000.00	200	30	29	26	2	62.5	125	16	9	10	15	9	35.0	1930.0	7.7	12.20
38 30 200	3	2000.00	200	30	29	26	2	without mounting holes										12.20
38 41 100	4	1000.00	75	40	39	35	2	62.5	125	8	12	10	15	9	33.3	933.4	7.7	10.90
38 40 100	4	1000.00	75	40	39	35	2	without mounting holes										10.90
38 41 200	4	2000.00	150	40	39	35	2	62.5	125	16	12	10	15	9	33.3	1933.4	7.7	21.80
38 40 200	4	2000.00	150	40	39	35	2	without mounting holes										21.80

500 mm and other length on request.

Total pitch error

$$GT_f/1000 \leq 0.100 \text{ mm}$$

$$GT_f/2000 \leq 0.200 \text{ mm}$$

- Milled teeth, quenched and tempered
- Heat-treatable steel according to ATLANTA-Standard
- Bright steel, backside machined



Mounting racks, see page ZF-2.

To achieve precision rack joints, we recommend our patented rack assembly kit, see page ZF-4.

For lubrication of racks & pinions, we recommend our automatic lubrication systems, see page ZE-1.

For the calculation and selection of the rack & pinion drive, see page ZD-1.

Screws for rack mounting, see page ZF-3.



ATLANTA-Quality 9

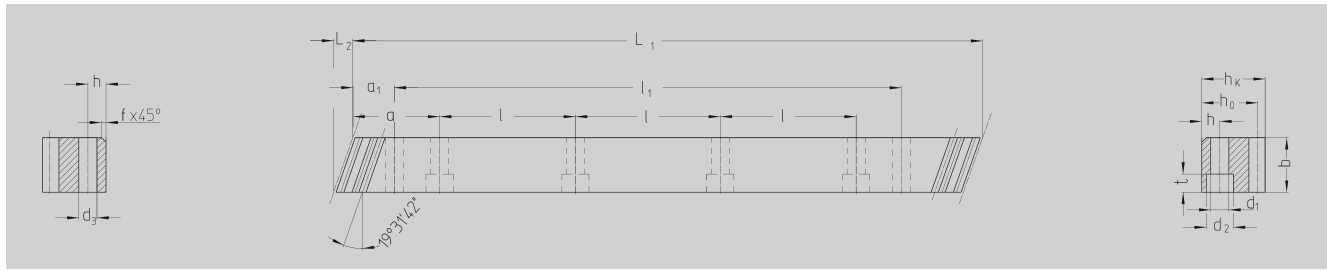

Order Code	Module	L ₁	L ₂	N° of Teeth	b	h _k	h ₀	f	a	l	N° of Holes	h	d ₁	d ₂	t	a ₁	l ₁	d ₃	kg
47 15 100	1.5	1000.00	6.0	200	17	17	15.5		62.5	125	8	6	6	10	6	31.7	936.6	5.7	1.30
47 16 100	1.5	1000.00	6.0	200	17	17	15.5		62.5	125	12	6	6	10	6	31.7	1436.6	5.7	1.30
47 15 150	1.5	1500.00	6.0	300	17	17	15.5		62.5	125	12	6	6	10	6	31.7	1436.6	5.7	1.95
47 16 150	1.5	1500.00	6.0	300	17	17	15.5		62.5	125	16	6	6	10	6	31.7	1936.6	5.7	1.95
47 15 200	1.5	2000.00	6.0	400	17	17	15.5		62.5	125	16	6	6	10	6	31.7	1936.6	5.7	2.60
47 16 200	1.5	2000.00	6.0	400	17	17	15.5		62.5	125	16	6	6	10	6	31.7	1936.6	5.7	2.60
47 20 050	2	500.00	9.2	75	26	24	22		62.5	125	4	8	7	11	7	31.7	436.6	5.7	2.20
47 21 050	2	500.00	9.2	75	26	24	22		62.5	125	8	8	7	11	7	31.7	936.6	5.7	2.20
47 20 100	2	1000.00	9.2	150	26	24	22		62.5	125	8	8	7	11	7	31.7	936.6	5.7	4.40
47 21 100	2	1000.00	9.2	150	26	24	22		62.5	125	16	8	7	11	7	31.7	1936.6	5.7	4.40
47 20 200	2	2000.00	9.2	300	26	24	22		62.5	125	16	8	7	11	7	31.7	1936.6	5.7	8.80
47 21 200	2	2000.00	9.2	300	26	24	22		62.5	125	16	8	7	11	7	31.7	1936.6	5.7	8.80
47 30 050	3	500.00	11.0	50	31	29	26		62.5	125	4	9	10	15	9	35.0	430.0	7.7	3.10
47 31 050	3	500.00	11.0	50	31	29	26		62.5	125	8	9	10	15	9	35.0	930.0	7.7	3.10
47 30 100	3	1000.00	11.0	100	31	29	26		62.5	125	8	9	10	15	9	35.0	930.0	7.7	6.20
47 31 100	3	1000.00	11.0	100	31	29	26		62.5	125	16	9	10	15	9	35.0	1930.0	7.7	6.20
47 30 200	3	2000.00	11.0	200	31	29	26		62.5	125	16	9	10	15	9	35.0	1930.0	7.7	12.50
47 31 200	3	2000.00	11.0	200	31	29	26		62.5	125	24	9	10	15	9	35.0	2930.0	7.7	12.50
47 30 300	3	3000.00	11.0	300	31	29	26		62.5	125	24	9	10	15	9	35.0	2930.0	7.7	18.60
47 31 300	3	3000.00	11.0	300	31	29	26		62.5	125	24	9	10	15	9	35.0	2930.0	7.7	18.60
47 40 050 ¹⁾	4	506.67	14.5	38	41	39	35		62.5	125	4	12	10	15	9	33.3	433.0	7.7	5.60
47 41 050	4	506.67	14.5	38	41	39	35		62.5	125	8	12	10	15	9	33.3	933.4	7.7	5.60
47 40 100	4	1000.00	14.5	75	41	39	35		62.5	125	8	12	10	15	9	33.3	933.4	7.7	11.10
47 41 100	4	1000.00	14.5	75	41	39	35		62.5	125	16	12	10	15	9	33.3	1933.4	7.7	11.10
47 40 200	4	2000.00	14.5	150	41	39	35		62.5	125	16	12	10	15	9	33.3	1933.4	7.7	22.20
47 41 200	4	2000.00	14.5	150	41	39	35		62.5	125	16	12	10	15	9	33.3	1933.4	7.7	22.20
47 50 100	5	1000.00	17.7	60	50	39	34		62.5	125	8	12	14	20	13	37.5	925.0	11.7	13.26
47 51 100	5	1000.00	17.7	60	50	39	34		62.5	125	16	12	14	20	13	37.5	1925.0	11.7	13.26
47 50 200	5	2000.00	17.7	120	50	39	34		62.5	125	16	12	14	20	13	37.5	1925.0	11.7	26.52
47 51 200	5	2000.00	17.7	120	50	39	34		62.5	125	16	12	14	20	13	37.5	1925.0	11.7	26.52
47 60 100	6	1000.00	21.3	50	60	49	43		62.5	125	8	16	18	26	17	37.5	925.0	15.7	20.12
47 61 100	6	1000.00	21.3	50	60	49	43		62.5	125	16	16	18	26	17	37.5	1925.0	15.7	20.12
47 60 200	6	2000.00	21.3	100	60	49	43		62.5	125	16	16	18	26	17	37.5	1925.0	15.7	40.24
47 61 200	6	2000.00	21.3	100	60	49	43		62.5	125	16	16	18	26	17	37.5	1925.0	15.7	40.24
47 80 100	8	960.00	28.7	36	81	79	71		60.0	120	8	25	22	33	21	120.0	720.0	19.7	44.85
47 81 100	8	960.00	28.7	36	81	79	71		60.0	120	16	25	22	33	21	120.0	1680.0	19.7	44.85
47 80 200	8	1920.00	28.7	72	81	79	71		60.0	120	16	25	22	33	21	120.0	1680.0	19.7	89.71
47 81 200	8	1920.00	28.7	72	81	79	71		60.0	120	16	25	22	33	21	120.0	1680.0	19.7	89.71
47 10 100	10	1000.00	35.5	30	100	99	89		62.5	125	8	32	33	48	32	125	750	19.7	69.80
47 11 100	10	1000.00	35.5	30	100	99	89		62.5	125	8	32	33	48	32	125	750	19.7	69.80

1) These racks should be used for continuous linking only with the left side (see sketch).

Total pitch error $GT_f/1000 \leq 0.150$ mm.

- Milled teeth
- Material C45
- Bright Steel

Mounting racks, see page ZF-2.

Further information see page ZA–10.





ATLANTA-Quality 10

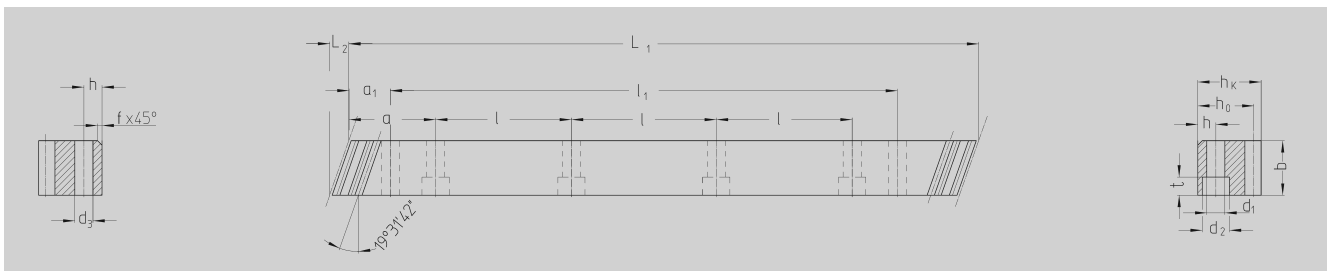

Order Code	Module	L ₁	L ₂	N° of Teeth	b	h _k	h ₀	f	a	l	N° of Holes	h	d ₁	d ₂	t	a ₁	l ₁	d ₃	kg	
39 15 050 ²⁾	1.5	500.00	6.02	100	17	17	15.5	2	62.5	125	4	6	6	10	6	31.7	436.6	5.7	1.30	
39 16 050	1.5	500.00	6.02	100	17	17	15.5	2				without Mounting Holes								1.30
39 15 100	1.5	1000.00	6.02	200	17	17	15.5	2	62.5	125	8	6	6	10	6	31.7	936.6	5.7	2.60	
39 16 100	1.5	1000.00	6.02	200	17	17	15.5	2				without Mounting Holes								2.60
39 20 050 ²⁾	2	500.00	8.87	75	25	24	22	2	62.5	125	4	8	7	11	7	31.7	436.6	5.7	2.10	
39 21 050	2	500.00	8.87	75	25	24	22	2				without Mounting Holes								2.10
39 20 100	2	1000.00	8.87	150	25	24	22	2	62.5	125	8	8	7	11	7	31.7	936.6	5.7	4.20	
39 21 100	2	1000.00	8.87	150	25	24	22	2				without Mounting Holes								4.20
39 20 200	2	2000.00	8.87	300	25	24	22	2	62.5	125	16	8	7	11	7	31.7	1936.6	5.7	8.40	
39 21 200	2	2000.00	8.87	300	25	24	22	2				without Mounting Holes								8.40
39 30 050 ²⁾	3	500.00	10.64	50	30	29	26	2	62.5	125	4	9	10	15	9	35.0	430.0	7.7	3.00	
39 31 050	3	500.00	10.64	50	30	29	26	2				without Mounting Holes								3.00
39 30 100	3	1000.00	10.64	100	30	29	26	2	62.5	125	8	9	10	15	9	35.0	930.0	7.7	6.00	
39 31 100	3	1000.00	10.64	100	30	29	26	2				without Mounting Holes								6.00
39 30 200	3	2000.00	10.64	200	30	29	26	2	62.5	125	16	9	10	15	9	35.0	1930.0	7.7	12.00	
39 31 200	3	2000.00	10.64	200	30	29	26	2				without Mounting Holes								12.00
39 40 050 ¹⁾²⁾	4	506.67	14.2	38	40	39	35	2	62.5	125	4	12	10	15	9	33.3	433.0	7.7	5.30	
39 41 050	4	506.67	14.2	38	40	39	35	2				without Mounting Holes								5.30
39 40 100 ²⁾	4	1000.00	14.2	75	40	39	35	2	62.5	125	8	12	10	15	9	33.3	933.4	7.7	10.50	
39 41 100	4	1000.00	14.2	75	40	39	35	2				without Mounting Holes								10.50
39 42 100	4	1000.00	14.2	75	40	39	35	2	62.5	125	8	12	14	20	13	33.3	933.4	11.7	10.50	
39 42 150 ¹⁾	4	1506.67	14.2	113	40	39	35	2	62.5	125	12	12	14	20	13	33.3	1433.4	11.7	15.75	
39 40 200	4	2000.00	14.2	150	40	39	35	2	62.5	125	16	12	10	15	9	33.3	1933.4	7.7	21.00	
39 41 200	4	2000.00	14.2	150	40	39	35	2				without Mounting Holes								21.00
39 42 200	4	2000.00	14.2	150	40	39	35	2	62.5	125	16	12	14	20	13	33.3	1933.4	11.7	21.00	
39 50 050 ²⁾	5	500.00	17.7	30	50	39	34	2.5	62.5	125	4	12	14	20	13	37.5	425.0	11.7	6.50	
39 51 050	5	500.00	17.7	30	50	39	34	2.5				without Mounting Holes								6.50
39 50 100	5	1000.00	17.7	60	50	39	34	2.5	62.5	125	8	12	14	20	13	37.5	925.0	11.7	13.00	
39 51 100	5	1000.00	17.7	60	50	39	34	2.5				without Mounting Holes								13.00
39 50 200	5	2000.00	17.7	120	50	39	34	2.5	62.5	125	16	12	14	20	13	37.5	1925.0	11.7	26.00	
39 51 200	5	2000.00	17.7	120	50	39	34	2.5				without Mounting Holes								26.00
39 60 050 ²⁾	6	500.00	21.4	25	60	49	43	2.5	62.5	125	4	16	18	26	17	37.5	425.0	15.7	9.90	
39 61 050	6	500.00	21.4	25	60	49	43	2.5				without Mounting Holes								9.90
39 60 100	6	1000.00	21.4	50	60	49	43	2.5	62.5	125	8	16	18	26	17	37.5	925.0	15.7	19.80	
39 61 100	6	1000.00	21.4	50	60	49	43	2.5				without Mounting Holes								19.80
39 60 200	6	2000.00	21.4	100	60	49	43	2.5	62.5	125	16	16	18	26	17	37.5	1925.0	15.7	39.60	
39 61 200	6	2000.00	21.4	100	60	49	43	2.5				without Mounting Holes								39.60

- 1) These racks should be used for continuous linking only with the left side (see sketch).
- 2) The screw joint limits the feed force.

Total pitch error $GT_f/1000 \leq 0.200$ mm.

- Milled teeth and induction hardened
- Material C45
- Backside machined, profile blasted

Further information see page ZA-13.



ATLANTA-Quality 10

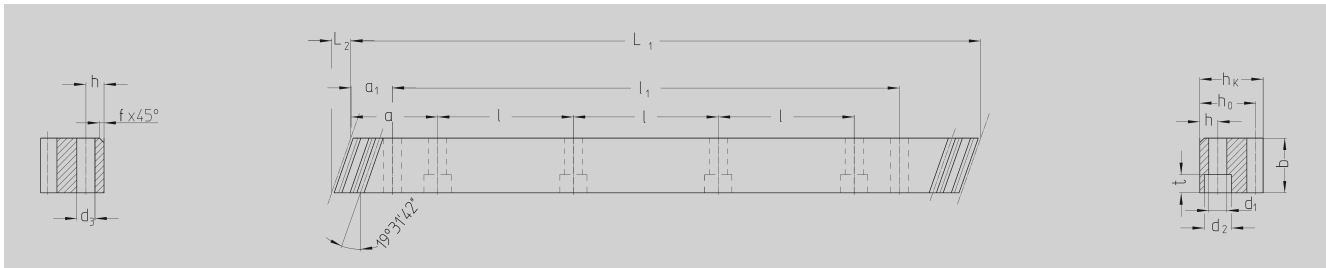

Order Code	Module	L ₁	L ₂	N° of Teeth	b	h _k	h ₀	f	a	l	N° of Holes	h	d ₁	d ₂	t	a ₁	l ₁	d ₃	kg
39 80 050 ²⁾	8	480.00	28.4	18	80	79	71	2.5	60.0	120	4	25	22	33	21	120.0	240	19.7	21.00
39 81 050	8	480.00	28.4	18	80	79	71	2.5					without Mounting Holes						21.00
39 80 100	8	960.00	28.4	36	80	79	71	2.5	60.0	120	8	25	22	33	21	120.0	720	19.7	42.50
39 81 100	8	960.00	28.4	36	80	79	71	2.5					without Mounting Holes						42.50
39 80 200	8	1920.00	28.4	72	80	79	71	2.5	60.0	120	16	25	22	33	21	120.0	1680	19.7	85.00
39 81 200	8	1920.00	28.4	72	80	79	71	2.5					without Mounting Holes						85.00
39 10 100	10	1000.00	35.46	30	100	99	89	2.5	62.5	125	8	32	33	48	32	125.0	750	19.7	68.72
39 11 100	10	1000.00	35.46	30	100	99	89	2.5					without Mounting Holes						68.72
39 12 100	12	1000.00	42.56	25	120	120	108	2.5	40.0	125	8	40	39	58	38	102.5	750	19.7	120.00
39 13 100	12	1000.00	42.56	25	120	120	108	2.5					without Mounting Holes						120.00

- 1) These racks should be used for continuous linking only with the left side (see sketch).
- 2) The screw joint limits the feed force.

Total pitch error $GT_f / 1000 \leq 0.200$ mm.

- Milled teeth and induction hardened
- Material C45
- Backside machined, profile blasted

Mounting racks, see page ZF-2.



To achieve precision rack joints, we recommend our patented rack assembly kit, see page ZF-4.

For lubrication of racks & pinions, we recommend our automatic lubrication systems, see page ZE-1.

For the calculation and selection of the rack & pinion drive, see page ZD-1.

Screws for rack mounting, see page ZF-3.



Bolt Circle-ø 50, helical tooth system, 19° 31' 42" left-hand

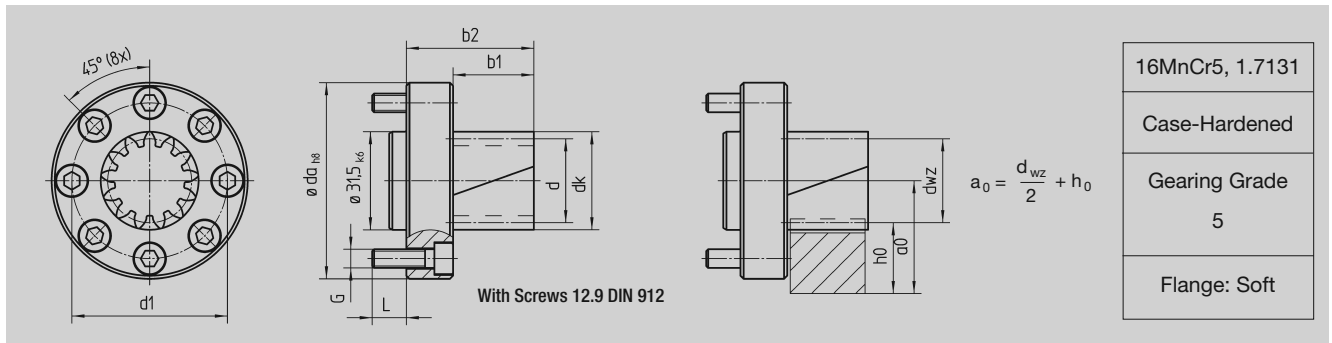

Order Code	No. of Teeth z	Profile Modification Factor x	Interface											
			d_{wz}	d_k	b_1	b_2	L	a_0	ISO	d_1	G	d_{ah8}	L	kg
Module 2														
78 21 912	12	0.5	27.46	31.50	26.0	41	80.00	35.73	9409-1-A-50	50	M6	63	11	0.5
78 21 916	16	0	33.95	37.95	26.0	41	106.67	38.98	9409-1-A-50	50	M6	63	11	0.6

Further number of teeth on request, min. number of teeth 12, max. number of teeth 16

Bolt Circle-ø 63, helical tooth system, 19° 31' 42" left-hand

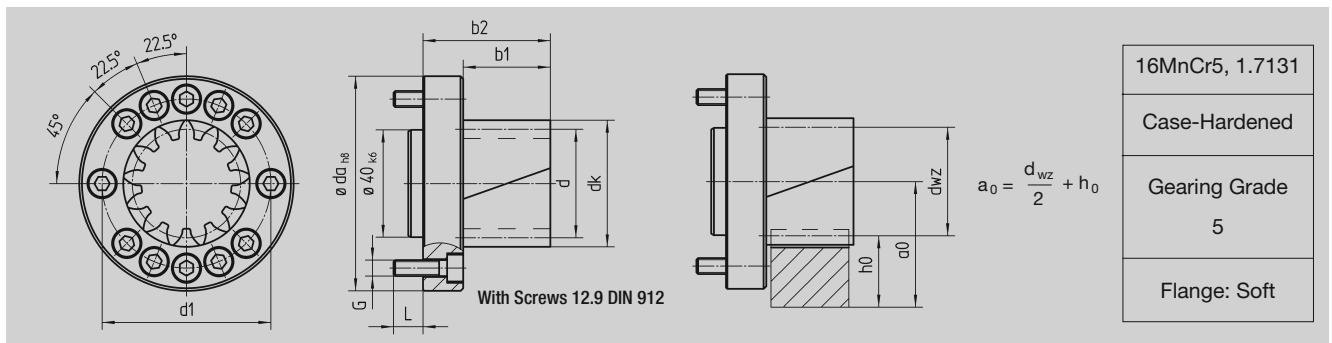

Order Code	No. of Teeth z	Profile Modification Factor x	Interface											
			d_{wz}	[mm] d_k	[mm] b_1	[mm] b_2	[mm] L	[mm] a_0	ISO	d_1	G	d_{ah8}	L	kg
Module 2														
78 22 912	12	0.5	27.46	31.5	26.0	41	80.00	35.73	9409-1-A-63	63	M6	80	11	0.8
78 22 919	19	0	40.32	44.3	26.0	41	126.67	42.16	9409-1-A-63	63	M6	80	11	0.9
78 22 923	23	0	48.81	52.8	26.0	41	153.33	46.40	9409-1-A-63	63	M6	80	11	1.0

Further number of teeth on request, min. number of teeth 12, max. number of teeth 23

Module 3														
78 32 912	12	0.5	41.20	47.2	32.5	47.5	120.00	46.60	9409-1-A-63	63	M6	80	11	1.0
78 32 914	14	0.3	46.36	52.4	32.5	47.5	140.00	49.18	9409-1-A-63	63	M6	80	11	1.0

Further number of teeth on request, min. number of teeth 12, max. number of teeth 14



Bolt Circle-ø 80, helical tooth system, 19° 31' 42" left-hand

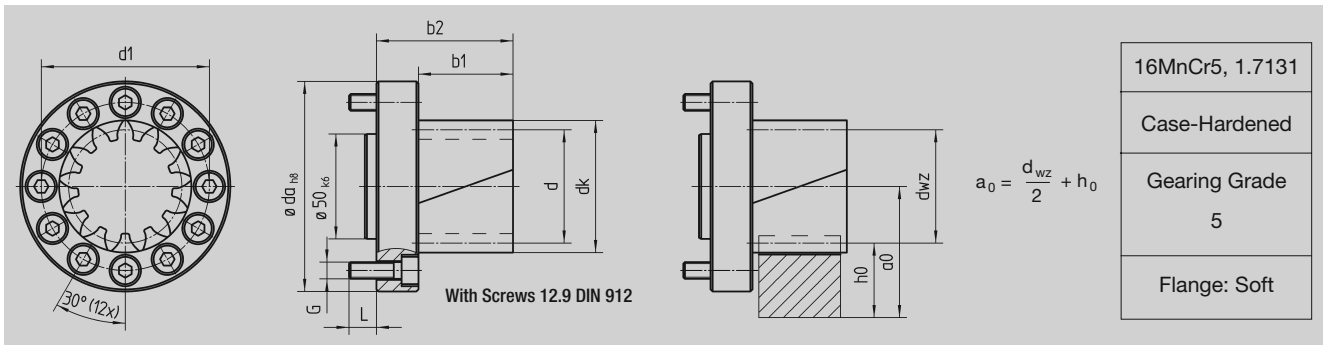

Order Code	No. of Teeth	Profile Modification Factor	Interface							ISO	d ₁	G	d _{ah8}	L	kg
			z	x	d _{wz}	d _k	b ₁	b ₂	L						
Module 2															
78 23 912	12	0.5	27.46	31.5	26.0	46	80.00	37.73	9409-1-A-80	80	M8	100	13	1.4	
78 23 923 ⁽¹⁾	23	0	48.81	52.8	26.0	46	153.33	46.40	9409-1-A-80	80	M8	100	13	1.6	
78 23 929 ⁽¹⁾	29	0	61.54	65.5	26.0	46	193.33	52.77	9409-1-A-80	80	M8	100	13	1.9	

Further number of teeth on request, min. number of teeth 12, max. number of teeth 29

Highlighted items will become obsolete in the future. Please check with the factory for delivery information.

Module 3															
78 33 912	12	0.5	41.20	47.2	32.5	52.5	120.00	46.60	9409-1-A-80	80	M8	100	13	1.6	
78 33 916	16	0	50.93	56.9	32.5	52.5	160.00	51.46	9409-1-A-80	80	M8	100	13	1.8	
78 33 917 ⁽¹⁾	17	0	54.11	60.1	32.5	52.5	170.00	53.06	9409-1-A-80	80	M8	100	13	1.9	
78 33 919	19	0	60.48	66.5	32.5	52.5	190.00	56.24	9409-1-A-80	80	M8	100	13	2.0	

Further number of teeth on request, min. number of teeth 12, max. number of teeth 19

Highlighted items will become obsolete in the future. Please check with the factory for delivery information.

Module 4															
78 43 912	12	0.5	54.93	62.9	45.0	65	160.00	62.46	9409-1-A-80	80	M8	100	13	2.1	

Further number of teeth on request, min. number of teeth 12, max. number of teeth 13

(1) Also available as pinion for counter bearing.





Bolt Circle- \varnothing 125, helical tooth system, $19^{\circ} 31' 42''$ left-hand

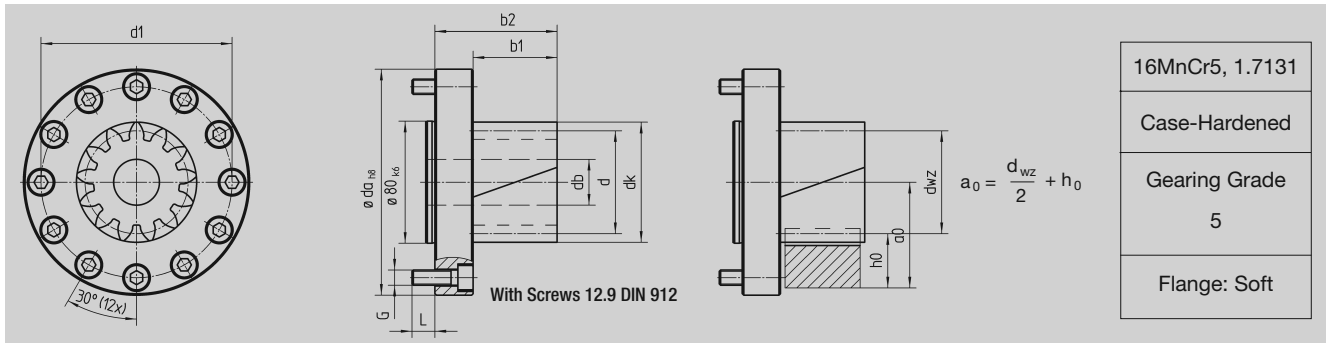

Order Code	No. of Teeth	Profile Modification Factor	Interface											kg	
			z	x	d_{wz}	d_k	b_1	b_2	L	a_0	ISO	d_1	G		d_{ah8}
Module 3															
78 34 912	12	0.5	41.20	47.20	32.5	57.5	120	46.60	9409-1-A-125	125	M10	148	15	-	3.8
78 34 312	12	0.5	41.20	47.20	32.5	57.5	120	46.60	-	125	M12	148	17	-	3.8
78 34 919	19	0	60.48	66.50	32.5	57.5	190	56.24	9409-1-A-125	125	M10	148	15	-	4.2
78 34 319	19	0	60.48	66.50	32.5	57.5	190	56.24	-	125	M12	148	17	-	4.2
78 34 925	25	0	79.58	85.60	32.5	57.5	250	65.79	9409-1-A-125	125	M10	148	15	-	4.8
78 34 926 ⁽¹⁾	26	0	82.76	88.80	32.5	57.5	260	67.38	9409-1-A-125	125	M10	148	15	-	4.9
78 34 326	26	0	82.76	88.80	32.5	57.5	260	67.38	-	125	M12	148	17	-	4.9
78 34 932 ⁽¹⁾	32	0	101.86	107.90	32.5	57.5	320	76.93	9409-1-A-125	125	M10	148	15	-	5.6
78 34 332	32	0	101.86	107.90	32.5	57.5	320	79.63	-	125	M12	148	17	-	5.6

Further number of teeth on request, min. number of teeth 12, max. number of teeth 32

Highlighted items will become obsolete in the future. Please check with the factory for delivery information.

Module 4															
78 44 912	12	0.5	54.93	62.90	45.0	70.0	160.00	62.46	9409-1-A-125	125	M10	148	15	-	4.4
78 44 312	12	0.5	54.93	62.90	45.0	70.0	160.00	62.46	-	125	M12	148	17	-	4.3
78 44 915	15	0	63.66	71.70	45.0	70.0	200.00	66.83	9409-1-A-125	125	M10	148	15	-	4.7
78 44 916	16	0	67.91	75.90	45.0	70.0	213.33	68.95	9409-1-A-125	125	M10	148	15	-	4.8
78 44 917	17	0	72.15	80.15	32.5	57.5	170.00	53.06	9409-1-A-125	125	M10	148	15	-	5.0
78 44 317	17	0	72.15	80.15	32.5	57.5	170.00	53.06	-	125	M12	148	17	-	5.0
78 44 919	19	0.11	81.52	89.50	45.0	70.0	256.10	75.76	9409-1-A-125	125	M10	148	15	-	5.4
78 44 319	19	0.11	81.52	89.50	45.0	70.0	256.10	75.76	-	125	M12	148	17	-	5.3
78 44 920 ⁽¹⁾	20	0	84.88	92.90	45.0	70.0	266.67	77.44	9409-1-A-125	125	M10	148	15	-	5.5
78 44 320	20	0	84.88	92.90	45.0	70.0	266.67	77.44	-	125	M12	148	17	-	5.5
78 44 923	23	0	97.62	105.60	45.0	70.0	306.67	83.81	-	125	M10	148	15	-	6.1

Further number of teeth on request, min. number of teeth 12, max. number of teeth 23

Highlighted items will become obsolete in the future. Please check with the factory for delivery information.

Module 5															
78 54 912	12	0.5	68.66	78.70	55	80	200.00	68.33 ⁽²⁾	9409-1-A-125	125	M10	148	15	-	5.1
78 54 312	12	0.5	68.66	78.70	55	80	200.00	68.33 ⁽²⁾	-	125	M12	148	17	-	5.1
78 54 916 ⁽¹⁾	16	0	84.88	94.90	55	80	266.67	76.44 ⁽²⁾	9409-1-A-125	125	M10	148	15	-	6.0
78 54 316	16	0	84.88	94.90	55	80	266.67	76.44 ⁽²⁾	-	125	M12	148	17	-	6.3
78 54 918	18	0	95.49	105.50	55	80	300.00	81.75 ⁽²⁾	9409-1-A-125	125	M10	148	15	-	6.6
78 54 318	18	0	95.49	105.50	55	80	300.00	81.75 ⁽²⁾	-	125	M12	148	17	-	6.6

Further number of teeth on request, min. number of teeth 12, max. number of teeth 18

Highlighted items will become obsolete in the future. Please check with the factory for delivery information.

Module 6															
78 64 912	12	0.5	82.39	94.40	65	90	240.00	84.20	9409-1-A-125	125	M10	148	15	25	5.8
78 64 312	12	0.5	82.39	94.40	65	90	240.00	84.20	-	125	M12	148	17	25	5.9
78 64 913	13	0.5	88.76	100.80	65	90	260.00	87.38	9409-1-A-125	125	M10	148	15	25	6.3
78 64 915	15	0	95.49	107.50	65	90	300.00	90.75	9409-1-A-125	125	M10	148	15	25	6.8

Further number of teeth on request, min. number of teeth 12, max. number of teeth 15

Highlighted items will become obsolete in the future. Please check with the factory for delivery information.

(1) Also available as pinion for counter bearing.

(2) For 29 55 ... $a'_0 = a_0 + 10$.



Bolt Circle- ϕ 140, helical tooth system, 19° 31' 42" left-hand

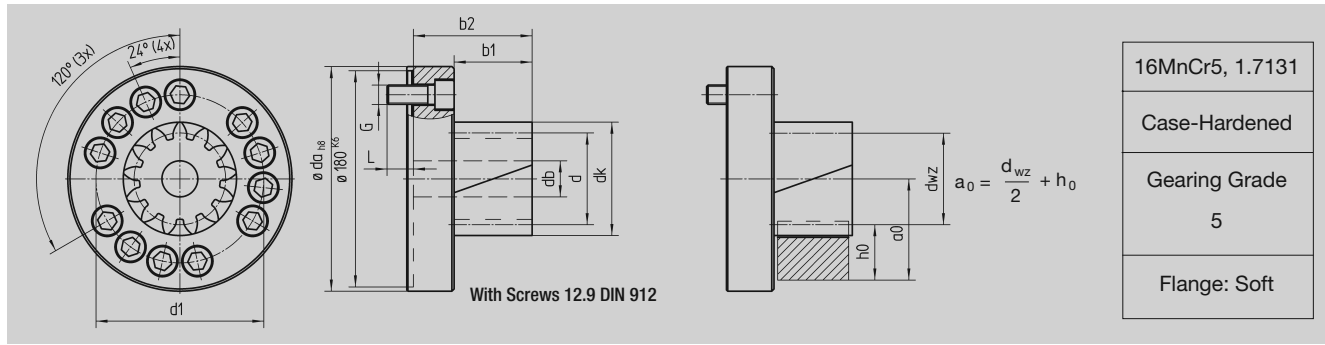

Order Code	No. of Teeth	Profile Modification Factor	Interface												
			d_{wz}	d_k	b_1	b_2	L	a_0	ISO	d_1	G	d_{aH8}	L	d_b	kg
Module 4															
78 46 912	12	0.5	54.93	62.90	45	79	160.00	62.46	-	140	M16	187	22	-	8.1
78 46 919	19	0.11	81.52	89.50	45	79	256.10	75.76	-	140	M16	187	22	-	9.1
78 46 920	20	0	84.88	92.90	45	79	266.67	77.40	-	140	M16	187	22	-	9.2
78 46 320	20	0	84.88	92.90	45	79	266.67	77.40	-	145	M20	187	16	-	9.6

Further number of teeth on request, min. number of teeth 12, max. number of teeth 25

Highlighted items will become obsolete in the future. Please check with the factory for delivery information.

Module 5

78 56 914	14	0.3	77.27	87.30	55	89	233.33	72.64 ⁽²⁾	-	140	M16	187	22	-	9.2
78 56 918	18	0	95.49	105.50	55	89	300.00	81.74 ⁽²⁾	-	140	M16	187	22	-	10.3
78 56 919	19	0	100.80	110.80	55	89	316.67	84.40 ⁽²⁾	-	140	M16	187	22	-	10.6

Further number of teeth on request, min. number of teeth 12, max. number of teeth 20

Highlighted items will become obsolete in the future. Please check with the factory for delivery information.

Module 6

78 66 912	12	0.5	82.39	94.40	65	99	240.00	84.20	-	140	M16	187	22	25	9.5
78 66 915	15	0	95.49	107.50	65	99	300.00	90.75	-	140	M16	187	22	25	10.5
78 66 916 ⁽¹⁾	16	0	101.86	113.90	65	99	320.00	93.93	-	140	M16	187	22	25	11.3

Further number of teeth on request, min. number of teeth 12, max. number of teeth 16

Highlighted items will become obsolete in the future. Please check with the factory for delivery information.

(1) Also available as pinion for counter bearing.

(2) For 29 55 ... $a'_0 = a_0 + 10$.





Bolt Circle-ø 160, helical tooth system, 19° 31' 42" left-hand

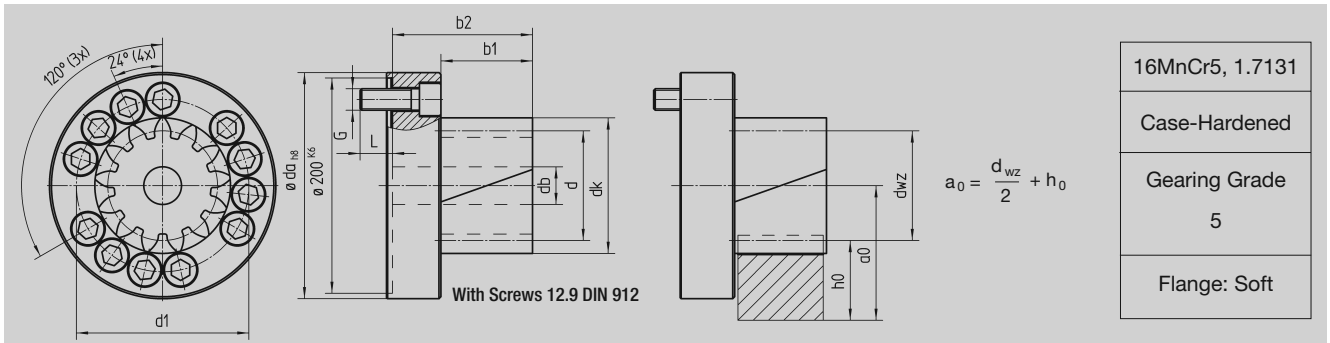

Order Code	No. of Teeth	Profile Modification Factor	Interface												
			d_{wz}	d_k	b_1	b_2	L	a_0	ISO	d_1	G	d_{ah8}	L	d_b	kg
Module 5															
78 57 912	12	0.5	68.66	78.7	55	100	200.00	68.33 ⁽¹⁾	-	160	M20	210	30	-	13.8
78 57 919	19	0	100.80	110.8	55	100	316.67	84.40 ⁽¹⁾	-	160	M20	210	30	-	15.6

Further number of teeth on request, min. number of teeth 12, max. number of teeth 22

Highlighted items will become obsolete in the future. Please check with the factory for delivery information.

Module 6															
78 67 912	12	0.5	82.39	94.4	65	110	240.00	84.20	-	160	M20	210	30	25	14.5
78 67 916	16	0	101.86	113.9	65	110	320.00	93.93	-	160	M20	210	30	25	15.9

Further number of teeth on request, min. number of teeth 12, max. number of teeth 18

Highlighted items will become obsolete in the future. Please check with the factory for delivery information.

Module 8															
78 87 912	12	0.5	109.86	125.9	85	130	320.00	125.93	-	160	M20	210	30	30	17.8

⁽²⁾ For 29 55 ... $a'_0 = a_0 + 10$.



Helical Tooth System, 19° 31' 42" left-hand

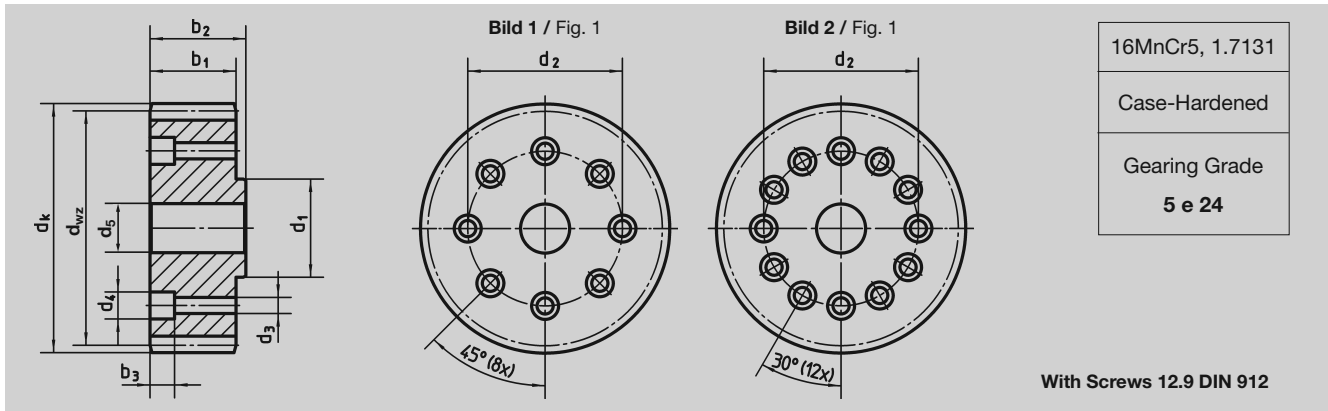

Order Code	Fig.	Module	N° of Teeth z	x ⁽¹⁾	d _{wz}	d _k	d _{1h6}	d ₂	d ₃	d ₄	d ₅ ^{H6}	b ₁	b ₂	b ₃	L=PI*d L	kg	Interface ISO
78 20 526	1	2	26	0.4065	56.80	60.60	20.0	31.5	5.5	10	15	26	29.0	12	173.33	0.4	9409-1-A-31.5
78 20 527	1	2	27	0	57.30	61.29	20.0	31.5	5.5	10	15	30	33.5	11	180.00	0.5	9409-1-A-31.5
78 20 529	1	2	29	0.4150	63.20	67.00	20.0	31.5	5.5	10	15	26	29.0	12	193.33	0.5	9409-1-A-31.5
78 20 535	1	2	35	0.3819	75.80	79.60	20.0	31.5	5.5	10	15	26	29.0	12	233.33	0.8	9409-1-A-31.5
78 25 529	1	2	29	0.4150	63.20	67.00	25.0	40.0	6.6	11	20	26	30.0	14	193.33	0.5	9409-1-A-40
78 21 533	1	2	33	0.3928	71.60	75.30	31.5	50.0	6.6	11	20	26	30.0	14	220.00	0.7	9409-1-A-50
78 20 536	1	2	36	0	76.40	80.39	31.5	50.0	6.6	11	20	30	34.0	8	240.00	1.2	9409-1-A-50
78 21 537	1	2	37	0.4209	80.20	84.00	31.5	50.0	6.6	11	20	26	30.0	14	246.67	0.9	9409-1-A-50
78 31 531	1	3	31	0.3540	100.80	106.60	31.5	50.0	6.6	11	20	31	35.5	9	310.00	1.8	9409-1-A-50
78 29 501	2	2	37	0.4209	80.20	84.00	31.5	50.0	6.6	11	20	26	30.0	14	246.67	0.9	9409-1-A-50

(1) Profile modification factor

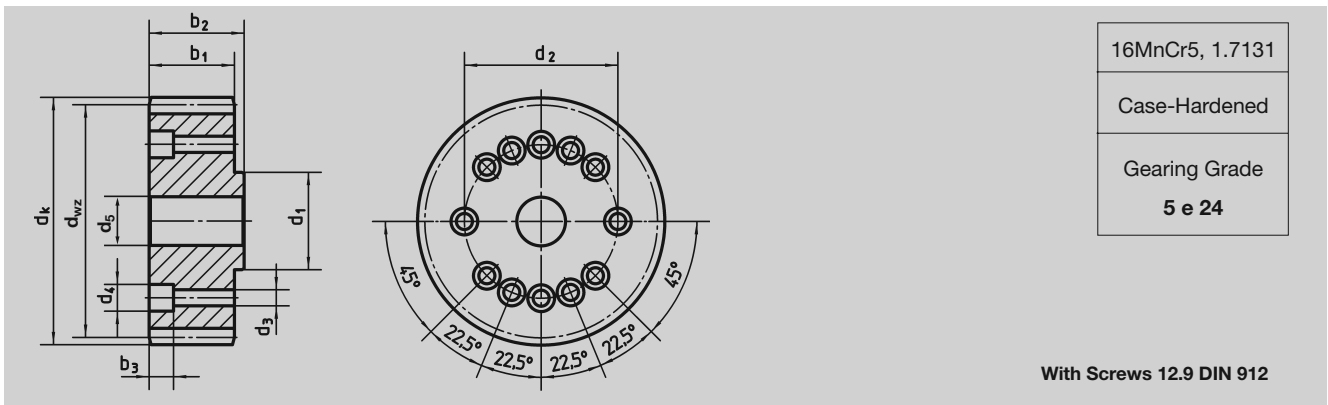

Order Code	Module	N° of Teeth z	x ⁽¹⁾	d _{wz}	d _k	d _{1h6}	d ₂	d ₃	d ₄	d ₅ ^{H6}	b ₁	b ₂	b ₃	L=PI*d L	kg	Interface ISO
78 22 540	2	40	0.3792	86.40	90.20	40.0	63.0	6.6	11	31.5	26	30	14	266.69	1.0	9409-1-A-63
78 22 545	2	45	0.3267	96.80	100.60	40.0	63.0	6.6	11	31.5	26	30	14	300.00	1.4	9409-1-A-63
78 30 530	3	30	0	95.49	101.49	40.0	63.0	6.6	11	20.0	35	39	10	300.00	2.2	9409-1-A-63

(1) Profile modification factor

The max. torque is limited by the threaded connection.

Calculation of center distance a between gearwheel and rack.

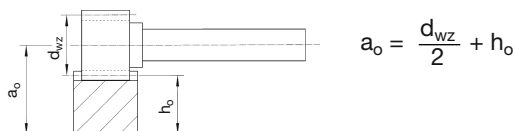



Helical Tooth System, 19° 31' 42" left-hand

16MnCr5, 1.7131

Case-Hardened

Gearing Grade

5 e 24

With Screws 12.9 DIN 912

Order Code	Module	N° of Teeth z	χ ⁽¹⁾	d _{wz}	d _k	d _{1h6}	d ₂	d ₃	d ₄	d ₅ ^{H6}	b ₁	b ₂	b ₃	L=PI*d		Interface ISO
														L	kg	
78 33 535	3	35	0.3652	113.60	119.40	50	80	9	15	40	31	35.0	11	350.00	1.8	9409-1-A-80
78 33 540	3	40	0.3792	129.60	135.40	50	80	9	15	40	31	35.0	11	400.00	2.5	9409-1-A-80
78 40 530	4	30	0	127.32	135.32	50	80	9	15	40	45	49.0	11	400.00	3.5	9409-1-A-80
78 50 521	5	21	0	111.40	121.40	50	80	9	-	40	59	64.5	-	350.00	3.5	9409-1-A-80
78 50 536	5	36	0	190.99	200.98	80	125	11	18	60	55	61.0	13	600.00	8.0	9409-1-A-125

(1) Profile modification factor
The max. torque is limited by the threaded connection.

Foil Coated with Diamonds to increase the Friction Coefficient

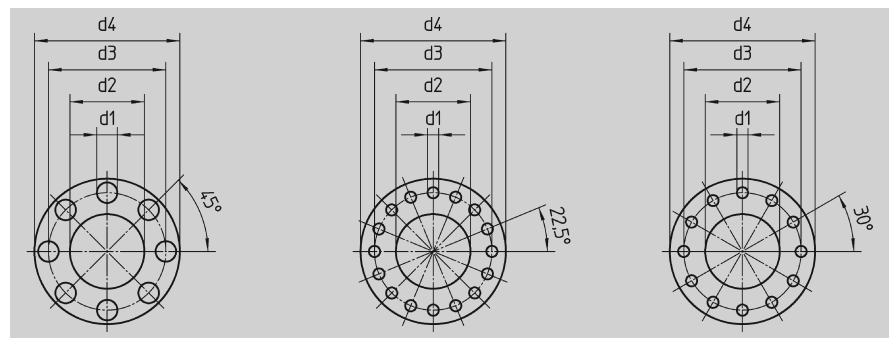

Order Code	Fig. No.	ISO Connection	d ₁	d ₂	d ₃	d ₄
78 01 001	Fig. 1	A – 31.5	5.5	20.0	31.5	39
78 01 002	Fig. 1	A – 50	6.6	31.5	50.0	62
78 01 003	Fig. 2	A – 63	6.6	40.0	63.0	80
78 01 004	Fig. 3	A – 80	9.0	50.0	80.0	100
78 01 005	Fig. 3	A – 125	11.0	80.0	125.0	148

A transmission of the torque in connections based on friction is limited by the friction coefficient of the materials which are used. The change of the size of a construction is sometimes not possible, so the only possibility to transmit a higher torque is to increase the coefficient of friction. The foil which is coated with diamonds is able to increase this friction coefficient.

Material	Rz [µm]	p [Mpa]	Coefficient of Friction			
			Static		Dynamic	
			Average from 5 test results	Standard deviation	Average from 5 test results	Standard deviation
C45	1-3	50	0.38	0.16	-	-
(HV = 262)		100	0.45	0.07	0.41	0.05
16MnCr5	1-3	50	0.46	0.14	-	-
(HV = 735)		100	0.34	0.05	0.38	0.11

If you need more information please contact us.



Helical Tooth System, 19° 31' 42" left-hand

Interface A50

16MnCr5, 1.7131
Case-Hardened
Gearing Grade 5 e 24
Flange: Soft

Set consists of Order Code Gear and Order Code Flange

With Screws 12.9 DIN 912

Order Code Pinion	Order Code Flange	Module	N° of Teeth z	x ⁽¹⁾	d _{wz}	d _k	d _{1h6}	d ₂	d ₃	d ₄	d ₅	d ₆	d ₇	b ₁	b ₂	b ₃	b ₄	L=PI*d L	kg	Interface ISO
78 20 526	265 78001	2	26	0.4065	56.80	60.60	31.5	50	63	20	1.5	6.6	11	26	36	2.5	6.5	173.33	0.6	9409-1-A-31.5/50
78 20 527	265 78001	2	27	0	57.30	61.29	31.5	50	63	20	1.5	6.6	11	30	40	2.5	6.5	180.00	0.7	9409-1-A-31.5/50
78 20 529	265 78001	2	29	0.4150	63.20	67.00	31.5	50	63	20	1.5	6.6	11	26	36	2.5	6.5	193.33	0.7	9409-1-A-31.5/50
78 20 535	265 78001	2	35	0.3819	75.80	79.60	31.5	50	63	20	1.5	6.6	11	26	36	2.5	6.5	233.33	1.0	9409-1-A-31.5/50

(1) Profile modification factor

Interface A63

16MnCr5, 1.7131
Case-Hardened
Gearing Grade 5 e 24
Flange: Soft

Set consists of Order Code Gear and Order Code Flange

With Screws 12.9 DIN 912

Order Code Pinion	Order Code Flange	Module	N° of Teeth z	x ⁽¹⁾	d _{wz}	d _k	d _{1h6}	d ₂	d ₃	d ₄	d ₅	d ₆	d ₇	b ₁	b ₂	b ₃	b ₄	L=PI*d L	kg	Interface ISO
78 20 526	265 78002	2	26	0.4065	56.80	60.60	40	63	80	20	1.5	6.6	11	26	36	3	6.5	173.33	0.7	9409-1-A-31.5/63
78 20 527	265 78002	2	27	0	57.30	61.29	40	63	80	20	1.5	6.6	11	30	40	3	6.5	180.00	0.8	9409-1-A-31.5/63
78 20 529	265 78002	2	29	0.4150	63.20	67.0	40	63	80	20	1.5	6.6	11	26	36	3	6.5	193.33	0.8	9409-1-A-31.5/63
78 20 535	265 78002	2	35	0.3819	75.80	79.60	40	63	80	20	1.5	6.6	11	26	36	3	6.5	233.33	1.1	9409-1-A-31.5/63

(1) Profile modification factor

The max. torque is limited by the threaded connection.





Helical Tooth System, 19° 31' 42" left-hand

Interface A80

16MnCr5, 1.7131
Case-Hardened
Gearing Grade 5 e 24
Flange: Soft

With Screws 12.9 DIN 912

Set consists of Order Code Gear and order Code Flange

Order Code Pinion	Order Code Flange	Module	N° of Teeth z	x ⁽¹⁾	d _{wz}	d _k	d _{1h6}	d ₂	d ₃	d ₄	d ₅	d ₆	d ₇	b ₁	b ₂	b ₃	b ₄	L=PI*d L	kg	Interface ISO
78 20 526	265 78001⁽²⁾ 265 78003⁽²⁾	2	26	0.4065	56.80	60.60	50	80	100	31.5	15	9	15	26	49	4	9	173.33	1.2	9409-1-A-31.5/50/80
78 20 527	265 78001⁽²⁾ 265 78003⁽²⁾	2	27	0	57.30	61.29	50	80	100	31.5	15	9	15	30	53	4	9	180.00	1.3	9409-1-A-31.5/50/80
78 20 529	265 78001⁽²⁾ 265 78003⁽²⁾	2	29	0.4150	63.20	67.00	50	80	100	31.5	15	9	15	26	49	4	9	193.33	1.3	9409-1-A-31.5/50/80
78 20 535	265 78001⁽²⁾ 265 78003⁽²⁾	2	35	0.3819	75.80	79.60	50	80	100	31.5	15	9	15	26	49	4	9	233.33	1.6	9409-1-A-31.5/50/80
78 21 533	265 78003	2	33	0.3928	71.60	75.30	50	80	100	31.5	20	9	15	26	39	4	9	220.00	1.3	9409-1-A-50/80
78 20 536	265 78003	2	36	0	76.40	80.40	50	80	100	31.5	20	9	15	30	43	4	9	240.00	1.4	9409-1-A-50/80
78 21 537	265 78003	2	37	0.4209	80.20	84.00	50	80	100	31.5	20	9	15	26	39	4	9	246.67	1.5	9409-1-A-50/80
78 31 531	265 78003	3	31	0.3540	100.80	106.60	50	80	100	31.5	20	9	15	31	44	4	9	310.00	2.4	9409-1-A-50/80

(1) Profile modification factor (2) 2 flange



Interface A125

16MnCr5, 1.7131
Case-Hardened
Gearing Grade 5 e 24
Flange: Soft

With Screws 12.9 DIN 912

Set consists of Order Code Gear and Order Code Flange

Order Code Pinion	Order Code Flange	Module	N° of Teeth z	x ⁽¹⁾	d _{wz}	d _k	d _{1h6}	d ₂	d ₃	d ₄	d ₅	d ₆	d ₇	b ₁	b ₂	b ₃	b ₄	L=PI*d L	kg	Interface ISO
78 31 531	265 78003⁽²⁾ 265 78004⁽²⁾	3	31	0.3540	100.80	106.60	80	125	148	50	20	11	18	31	63	6	14	310.00	3.4	9409-1-A-50/80/125
78 33 535	265 78004	3	35	0.3652	113.60	119.40	80	125	148	50	40	11	18	31	50	6	14	350.00	3.8	9409-1-A80/125
78 33 540	265 78004	3	40	0.3792	129.60	135.40	80	125	148	50	40	11	18	31	50	6	14	400.00	4.5	9409-1-A80/125
78 40 530	265 78004	4	30	0	127.32	135.32	80	125	148	50	40	11	18	45	64	6	14	400.00	5.5	9409-1-A80/125
78 50 521	265 78004	5	21	0	111.40	121.40	80	125	148	50	40	11	18	59	78	6	14	350.00	5.5	9409-1-A80/125

(1) Profile modification factor (2) 2 flange

The max. torque is limited by the threaded connection.



Helical Tooth System, 19° 31' 42" left-hand

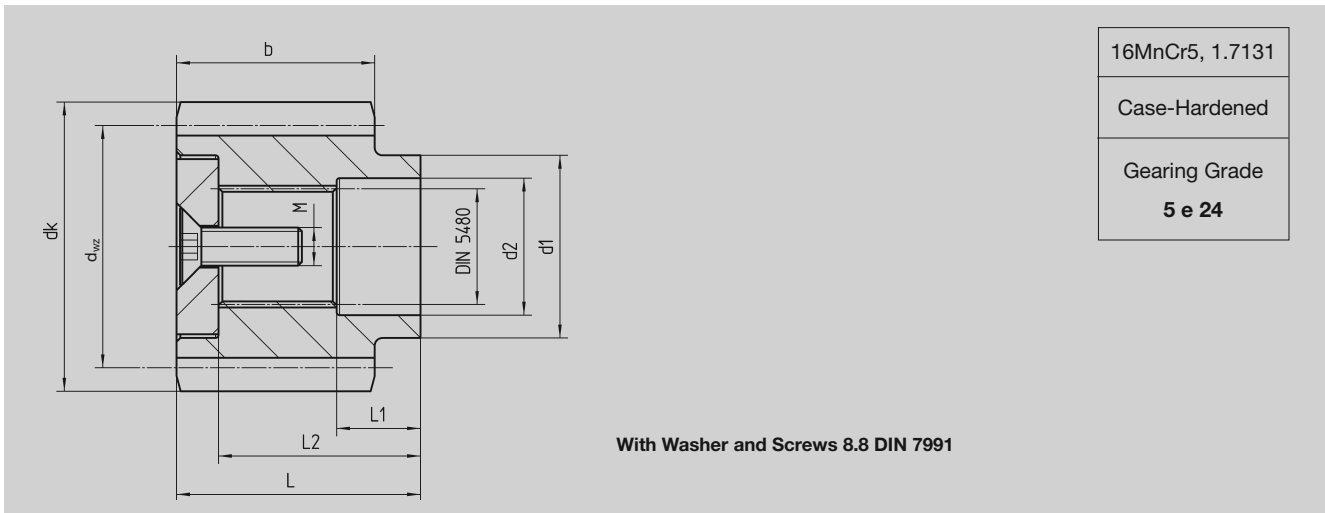

Order Code	N° of Teeth	Module	Profile Modification Factor	d_{wz}	d_k	d_1	L	d_2	L_1	L_2	b	M	DIN 5480	kg
79 11 538	38	1.5	-	60.48	63.48	30	33	24	12	27.5	20	M8x25	N22x1.25x30x16x7H	0.1
79 20 515	15	2	0.5922	34.20	38.0	24	32	18	11	26.5	26	M5x16	N16x0.8x30x18x7H	0.2
79 20 516	16	2	0.6117	36.40	40.1	24	32	18	11	26.5	26	M5x16	N16x0.8x30x18x7H	0.2
79 20 518	18	2	0.5000	40.20	44.0	24	32	18	11	26.5	26	M5x16	N16x0.8x30x18x7H	0.3
79 21 518	18	2	0.5000	40.20	44.0	30	33	24	12	27.5	26	M8x25	N22x1.25x30x16x7H	0.3
79 21 520	20	2	0.4900	44.40	48.2	30	33	24	12	27.5	26	M8x25	N22x1.25x30x16x7H	0.3
79 21 522	22	2	0.4786	48.60	52.5	30	33	24	12	27.5	26	M8x25	N22x1.25x30x16x7H	0.4
79 21 525	25	2	-	53.05	57.05	30	33	24	12	27.5	26	M8x25	N22x1.25x30x16x7H	0.4
79 22 523	23	2	0.4981	50.80	54.6	40	34	35	13	27.0	26	M12x35	N32x1.25x30x24x7H	0.4
79 22 525	25	2	0.4871	55.00	59.0	40	34	35	13	27.0	26	M12x35	N32x1.25x30x24x7H	0.4
79 22 527	27	2	0.3760	58.80	62.6	40	34	35	13	27.0	26	M12x35	N32x1.25x30x24x7H	0.5
79 33 520	20	3	0.4563	66.40	72.2	50	51	41	20	41.0	31	M16x45	N40x2x30x18x7H	0.7
79 33 522	22	3	0.4620	72.80	78.6	50	51	41	20	41.0	31	M16x45	N40x2x30x18x7H	0.8
79 33 524	24	3	0.4676	79.20	85.0	50	51	41	20	41.0	31	M16x45	N40x2x30x18x7H	1.0
79 44 520	20	4	0.4000	88.08	96.1	75	54	56	20	44.0	41	M20x50	N55x2x30x26x7H	1.5
79 45 525	25	4	0.3400	108.82	116.8	90	65	72	24	55.0	41	M20x50	N70x2x30x34x7H	3.0



Calculation of center distance a between gearwheel and rack.





Helical Tooth System, Ground Teeth, 19° 31' 42" left-hand, with Bore ØH6 and Keyway acc. to DIN 6885

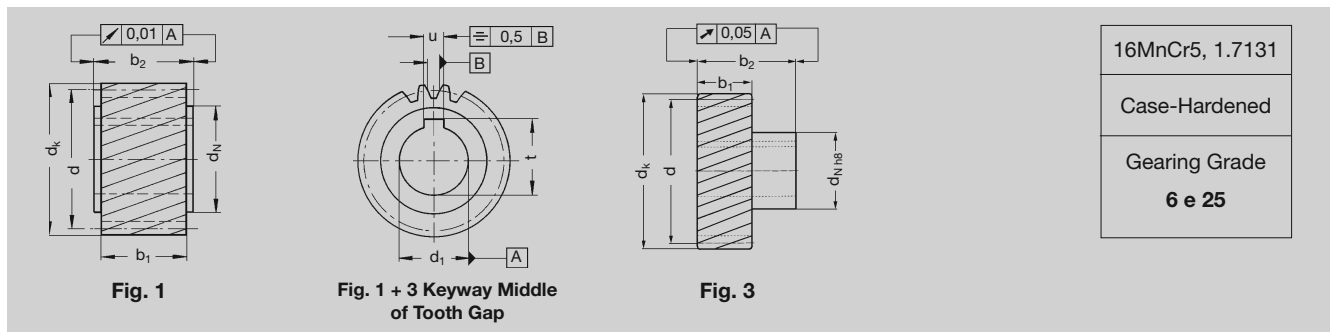

Order Code	Fig.	N° of Teeth z	d	d*PI	d _k	d ₁ H6	d _N	b ₁	b ₂	u	t	kg	Shrink-Disk on Page GH-1
Module 1.5													
24 11 520 ¹⁾	1	20	31.83	100.00	34.83	11	25	20	22	4	12.8	0.13	
24 14 520 ¹⁾	1	20	31.83	100.00	34.83	14	25	20	22	5	16.3	0.13	
24 16 520 ¹⁾	1	20	31.83	100.00	34.83	16	25	20	22	5	18.3	0.13	
24 16 321 ¹⁾	3	21	33.42	105.00	36.42	16	30	20	46	5	18.3	0.15	80 83 030
Module 2													
24 26 518	1	18	38.197	120.00	42.2	16	25	28	30	5	18.3	0.2	
24 29 520	1	20	42.44	133.33	46.4	19*	30	28	30	6	21.8	0.3	
24 29 320	3	20	42.44	133.33	46.4	19*	30	28	56	6	21.8	0.3	80 83 030
24 22 520	1	20	42.44	133.33	46.4	20	30	28	30	6	22.8	0.3	
24 20 320	3	20	42.44	133.33	46.4	22*	36	28	56	6	24.8	0.3	80 84 036
24 23 520	1	20	42.44	133.33	46.4	22	30	28	30	6	24.8	0.3	
24 26 521	1	21	44.56	140.00	48.6	16	25	28	30	5	18.3	0.3	
24 20 321	3	21	44.56	140.00	48.6	22	36	28	56	6	24.8	0.2	80 84 036
24 29 522	1	22	46.69	146.67	50.7	19*	30	28	30	6	21.8	0.2	
24 29 322	3	22	46.69	146.67	50.7	19*	30	28	56	6	21.8	0.2	80 83 030
24 20 522	1	22	46.69	146.67	50.7	22*	30	28	30	6	24.8	0.3	
24 20 322	3	22	46.69	146.67	50.7	22*	36	28	56	6	24.8	0.3	80 84 036
24 29 525	1	25	53.05	166.67	57.1	19*	30	28	30	6	21.8	0.4	
24 29 325	3	25	53.05	166.67	57.1	19*	30	28	56	6	21.8	0.4	80 83 030
24 22 525	1	25	53.05	166.67	57.1	20	30	28	30	6	22.8	0.4	
24 20 525	1	25	53.05	166.67	57.1	22*	30	28	30	6	24.8	0.3	
24 20 325	3	25	53.05	166.67	57.1	22*	36	28	56	6	24.8	0.3	80 84 036
24 23 525	1	25	53.05	166.67	57.1	25	36	28	30	8	28.3	0.4	
24 29 528	1	28	59.42	186.67	63.4	19*	30	28	30	6	21.8	0.4	
24 29 328	3	28	59.42	186.67	63.4	19*	30	28	56	6	21.8	0.4	80 83 030
24 20 528	1	28	59.42	186.67	63.4	22*	30	28	30	6	24.8	0.4	
24 20 328	3	28	59.42	186.67	63.4	22*	36	28	56	6	24.8	0.4	80 84 036
24 25 528	1	28	59.42	186.67	63.4	35	48	28	30	10	38.3	0.4	
24 26 530	1	30	63.66	200.00	67.7	16	25	28	30	5	18.3	0.7	
24 22 530	1	30	63.66	200.00	67.7	20	30	28	30	6	22.8	0.6	
24 20 330	3	30	63.66	200.00	67.7	22	36	28	56	6	24.8	0.6	80 84 036
24 23 530	1	30	63.66	200.00	67.7	25	36	28	30	8	28.3	0.8	
24 24 530	1	30	63.66	200.00	67.7	30*	45	28	30	8	33.3	0.8	
24 22 330	3	30	63.66	200.00	67.7	30	50	28	60	8	33.3	0.8	80 85 050
24 23 330	3	30	63.66	200.00	67.7	32	55	28	65	10	35.3	0.8	80 80 055
24 22 532	1	32	67.91	213.33	71.9	20	30	28	30	6	22.8	0.8	
24 20 532	1	32	67.91	213.33	71.9	22*	30	28	30	6	24.8	0.7	
24 20 332	3	32	67.91	213.33	71.9	22*	36	28	56	6	27.8	0.7	80 84 036
24 23 532	1	32	67.91	213.33	71.9	25	36	28	30	8	28.3	0.7	
24 25 532	1	32	67.91	213.33	71.9	35	48	28	30	10	38.3	0.6	
24 25 536	1	36	76.39	240.00	80.4	35	48	28	30	10	38.3	0.8	
24 23 339	3	39	82.76	260.00	86.8	32	55	28	65	10	35.3	1.3	80 80 055
24 25 540	1	40	84.88	266.67	88.9	35	48	28	30	10	38.3	1.1	

* H7 tolerance

¹⁾ Gearing grade 6 f 24



Helical Tooth System, Ground Teeth, 19° 31' 42" left-hand, with Bore ØH6 and Keyway acc. to DIN 6885

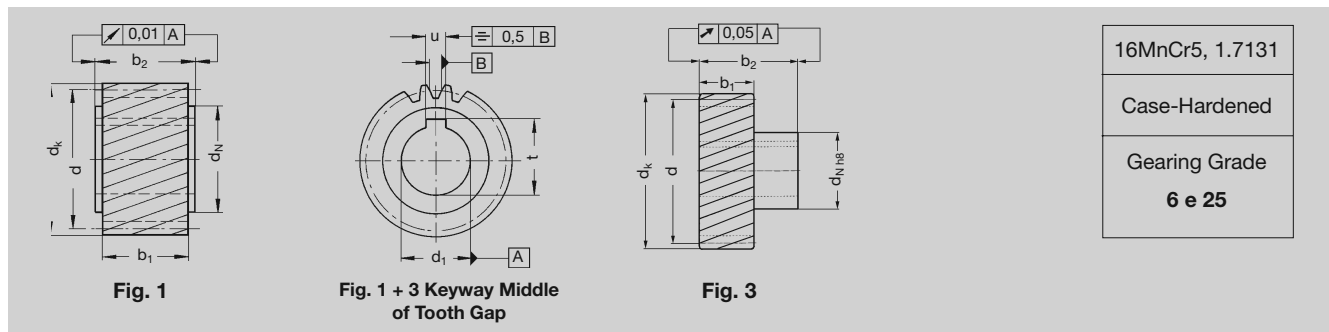

Order Code	Fig.	N° of Teeth z	d	d*PI	d _k	d ₁ ^{H6}	d _N	b ₁	b ₂	u	t	kg	Shrink-Disk on Page GH-1
Module 3													
24 30 320	3	20	63.66	200.00	69.7	22	36	28	56	6	24.8	0.6	80 84 036
24 31 320	3	20	63.66	200.00	69.7	25	44	28	60	8	28.3	0.7	80 80 044
24 34 520	1	20	63.66	200.00	69.7	30	45	28	30	8	33.3	0.8	
24 32 320	3	20	63.66	200.00	69.7	30	50	28	60	8	33.3	0.8	80 85 050
24 33 320	3	20	63.66	200.00	69.7	32	55	28	65	10	35.3	0.8	80 80 055
24 35 520	1	20	63.66	200.00	69.7	35	48	28	30	10	38.3	0.7	
24 33 522	1	22	70.03	220.00	76.0	25	36	28	30	8	28.3	0.8	
24 34 522	1	22	70.03	220.00	76.0	30	45	28	30	8	33.3	0.7	
24 33 322	3	22	70.03	220.00	76.0	32*	55	28	65	10	35.3	1.0	80 80 055
24 35 522	1	22	70.03	220.00	76.0	35	48	28	30	10	38.3	0.7	
24 35 322	3	22	70.03	220.00	76.0	40*	62	28	65	12	43.3	1.0	80 86 062
24 30 325	3	25	79.58	250.00	85.6	22	36	28	56	6	24.8	1.0	80 84 036
24 33 525	1	25	79.58	250.00	85.6	25	36	28	30	8	28.3	1.0	
24 31 325	3	25	79.58	250.00	85.6	25	44	28	60	8	28.3	1.1	80 80 044
24 34 525	1	25	79.58	250.00	85.6	30	45	28	30	8	33.3	1.0	
24 32 325	3	25	79.58	250.00	85.6	30	50	28	60	8	33.3	1.2	80 85 050
24 33 325	3	25	79.58	250.00	85.6	32	55	28	65	10	35.3	1.2	80 80 055
24 35 525	1	25	79.58	250.00	85.6	35	48	28	30	10	38.3	0.9	
24 34 325	3	25	79.58	250.00	85.6	35	55	28	65	10	38.3	1.1	80 80 055
24 36 525	1	25	79.58	250.00	85.6	40	70	28	50	12	43.3	1.1	
24 35 325	3	25	79.58	250.00	85.6	40*	62	28	65	12	43.3	1.1	80 86 062
24 33 328	3	28	89.13	280.00	95.1	32*	55	28	65	10	35.3	1.1	80 80 055
24 35 328	3	28	89.13	280.00	95.1	40*	62	28	65	12	43.3	1.1	80 86 062
24 33 332	3	32	101.86	320.00	107.85	32*	55	28	65	10	35.3	2.1	80 80 055
24 35 332	3	32	101.86	320.00	107.85	40*	62	28	65	12	43.3	2.1	80 86 062

* H7 tolerance





Helical Tooth System, Ground Teeth, 19° 31' 42" left-hand, with Bore ØH6 and Keyway acc. to DIN 6885

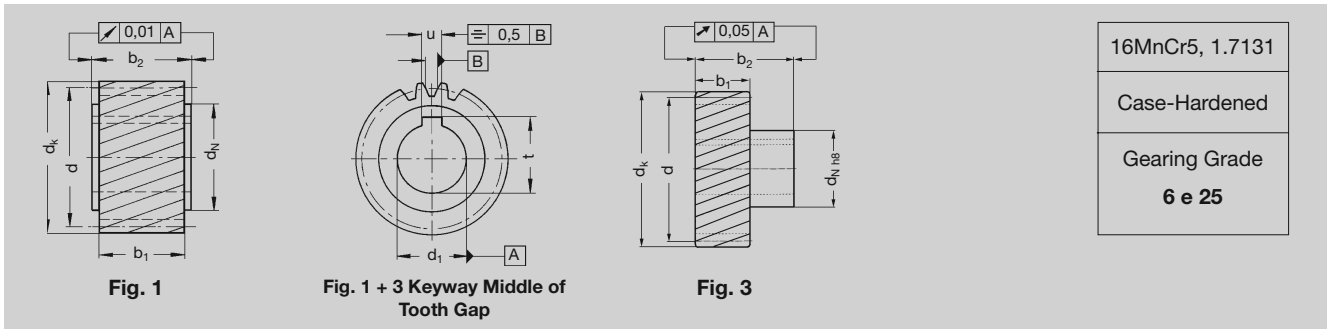

16MnCr5, 1.7131
Case-Hardened
Gearing Grade 6 e 25

Order Code	Fig.	N° of Teeth z	d	d*PI	dk	d1 ^{H6}	dN	b1	b2	u	t	kg	Shrink-Disk on Page GH-1
Module 4													
24 45 515	1	15	63.66	200.00	71.7	35	52	40	50	10	38.3	1.4	
24 43 318	3	18	76.39	240.00	84.4	32	55	40	75	10	35.3	1.5	80 80 055
24 45 520	1	20	84.88	266.67	92.9	35	52	40	50	10	38.3	1.9	
24 47 520	1	20	84.88	266.67	92.9	45	65	40	50	14	48.8	1.6	
24 43 321	3	21	89.13	280.00	97.1	32	55	40	75	10	35.3	2.0	80 80 055
24 44 321	3	21	89.13	280.00	97.1	35	55	40	75	10	38.3	1.9	80 80 055
24 45 321	3	21	89.13	280.00	97.1	40	62	40	75	12	43.3	1.9	80 86 062
24 46 321	3	21	89.13	280.00	97.1	45	68	40	75	14	48.8	1.7	80 80 068
24 45 522	1	22	93.37	293.33	101.4	35	52	40	50	10	38.3	2.3	
24 47 522	1	22	93.37	293.33	101.4	45	65	40	50	14	48.8	2.0	
24 43 324	3	24	101.86	320.00	109.9	32	55	40	75	10	35.3	2.6	80 80 055
24 44 324	3	24	101.86	320.00	109.9	35	55	40	75	10	38.3	2.5	80 80 055
24 45 324	3	24	101.86	320.00	109.9	40	62	40	75	12	43.3	2.5	80 86 062
24 46 324	3	24	101.86	320.00	109.9	45	68	40	75	14	48.8	2.3	80 80 068
24 47 324	3	24	101.86	320.00	109.9	55	80	40	80	16	59.3	2.4	80 87 080
24 45 525	1	25	106.10	333.33	114.1	35	52	40	50	10	38.3	3.1	
24 47 525	1	25	106.10	333.33	114.1	45	65	40	50	14	48.8	2.8	
24 47 325	3	25	106.10	333.33	114.1	55	80	40	80	16	59.3		80 87 080
Module 5													
24 56 318	3	18	95.49	300.00	105.5	45	68	50	85	14	48.8	2.7	80 80 068
24 56 324	3	24	127.32	400.00	137.3	45	68	50	85	14	48.8	4.9	80 80 068
24 57 324	3	24	127.32	400.00	137.3	55	80	50	90	16	59.3	4.9	80 87 080
24 58 324	3	24	127.32	400.00	137.3	75	110	50	110	20	79.9	5.6	80 80 110
Module 6													
24 67 320	3	20	127.32	400.00	139.3	55	80	60	100	16	59.3	5.7	80 87 080
24 68 320	3	20	127.32	400.00	139.3	75	110	60	120	20	79.9	6.3	80 80 110
24 67 325	3	25	159.16	500.00	171.2	55	80	60	100	16	59.3	9.0	80 87 080
24 68 325	3	25	159.16	500.00	171.2	75	110	60	120	20	79.9	9.6	80 80 110
Module 8													
24 88 318	3	18	152.79	480.00	168.8	75	110	80	140	20	79.9	10.8	80 80 110
24 89 320*	3	20	169.80	533.44	185.8	85	125	80	145	22	90.4	13.6	80 80 125
Module 10													
24 09 720*		20	212.21	666.68	232.2	85	125	100	165	22	90.4	26.2	80 80 125

* Gearing grade 5 f 23



Helical Tooth System, left-hand, 19° 31' 42", without Bore

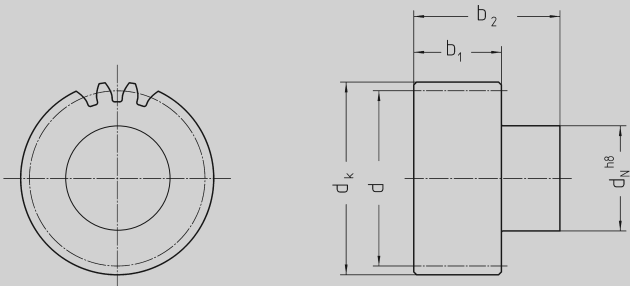

16MnCr5, 1.7131
Carburized, Teeth Induction Hardened
Gearing Grade 6 e 25

Order Code	Module	N° of Teeth	d	d*PI	d _k	d _N	b ₁	b ₂	kg	Shrink-Disk on Page GH-1
24 99 121	1.5	21	33.42	105.00	36.4	30	20	46	0.3	80 83 030
24 99 218	2	18	38.20	120.00	42.2	30	28	56	0.3	80 83 030
24 99 220	2	20	42.44	133.33	46.4	30	28	56	0.4	80 83 030
24 99 222	2	22	46.69	146.67	50.7	36	28	56	0.5	80 84 036
24 99 225	2	25	53.05	166.67	57.1	44	28	60	0.8	80 80 044
24 99 228	2	28	59.42	186.67	63.4	50	28	60	1.0	80 85 050
24 99 230	2	30	63.66	200.00	67.7	50	28	60	1.1	80 85 050
24 99 232	2	32	67.91	213.33	71.9	55	28	65	1.4	80 80 055
24 99 318	3	18	57.30	180.00	63.3	44	28	60	0.8	80 80 044
24 99 320	3	20	63.66	200.00	69.7	50	28	60	1.0	80 85 050
24 99 322	3	22	70.03	220.00	76.0	55	28	65	1.4	80 80 055
24 99 325	3	25	79.58	250.00	85.6	62	28	65	1.8	80 86 062
24 99 328	3	28	89.13	280.00	95.1	68	28	65	2.3	80 80 068
24 99 418	4	18	76.39	240.00	84.4	62	40	77	2.0	80 86 062
24 99 420	4	20	84.88	266.67	92.9	62	40	77	2.4	80 86 062
24 99 421	4	21	89.13	280.00	97.1	68	40	77	2.8	80 80 068
24 99 422	4	22	93.37	293.33	101.4	68	40	77	2.9	80 80 068
24 99 424	4	24	101.86	320.00	109.9	80	40	80	3.9	80 87 080
24 99 425	4	25	106.10	333.33	114.1	80	40	80	4.0	80 87 080
24 99 522	5	22	116.71	366.67	126.7	80	50	90	5.5	80 87 080
24 99 524	5	24	127.32	400.00	137.3	110	50	110	9.6	80 80 110
24 99 525	5	25	132.63	416.67	142.6	110	50	110	9.1	80 80 110
24 99 620	6	20	127.32	400.00	139.3	110	60	120	9.7	80 80 110
24 99 820 ¹⁾	8	20	169.77	533.33	185.8	125	80	145	19.4	80 80 125

¹⁾ With bore Ø40^{H7}

The pinion could be fixed at d_k or d_n to be reworked (see page ZF-10).

Maximum bore diameter of the pinion on request.





Helical Tooth System, left-hand, 19° 31' 42", prebored

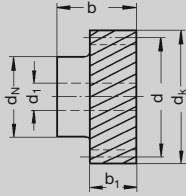

Soft
Ck45 1.0503
Gearing Grade 8 e 25

Order Code	N° of Teeth	b ₁	b	d	d _k	d ₁ ^(J8)	d _N	kg
Module 1.5								
21 15 520	20	17	30	31.83	34.8	9	25	0.14
21 15 525	25	17	30	39.79	42.8	9	30	0.22
Module 2								
21 20 520	20	28	35	42.44	46.4	9	30	0.35
21 20 525	25	28	35	53.05	57.1	12	35	0.54
21 20 530	30	28	35	63.66	67.7	12	40	0.76
Module 3								
21 30 520	20	30	50	63.66	69.7	14	45	0.99
21 30 525	25	30	50	79.58	85.6	14	60	1.60
Module 4								
21 40 515	15	40	60	63.66	71.7	16	50	1.10
21 40 520	20	40	60	84.88	92.9	16	60	2.21
21 40 525	25	40	60	106.10	114.1	16	75	3.45

Further finishing (turning bores, keywaying, threading, etc.) is possible within short time.





Helical Tooth System, left-hand, 19° 31' 42", prebored

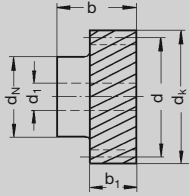

Soft
Ck45 1.0503
Gearing Grade 8 e 25

Order Code	N° of Teeth	b ₁	b	d	d _k	d ₁ ^(J8)	d _N	
Module 5								
21 50 520	20	50	70	106.10	116.1	20	70	4.0
21 50 525	25	50	70	132.60	142.6	20	80	6.2
Module 6								
21 60 520	20	60	80	127.30	139.3	20	90	7.0
21 60 525	25	60	80	159.20	171.2	20	110	10.8
Module 8								
21 80 520	20	80	120	166.08	182.0	40	120	15.8
Module 10*								
21 10 518	18	100	150	190.99	211.0	40	150	32.7
Module 12*								
21 12 518	18	130	180	229.18	253.18	40	170	47.2

* With threads for handling

Further finishing (turning bores, keywaying, threading, etc.) is possible within short time.



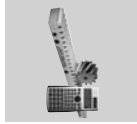

ATLANTA

Rack and Pinion Drive – Calculation and Selection – Module 1.5 – Helical Tooth System

Rack		HPR	BR	
Quality		6	9	10
Rack	Material	C45	C45	C45
	Heat Treatment	Ind. Hardened	Soft	Ind. Hardened
Pinion	Material	16MnCr5	C45	C45
	Heat Treatment	Case Hardened	Soft	Ind. Hardened
No. of Pinion Teeth ¹⁾	Pitch Circle Dia.	Max. Feed Force		
12	19.10 mm	3.0 kN	0.4 kN	1.5 kN
13	20.69 mm	3.0 kN	0.4 kN	1.5 kN
14	22.28 mm	4.0 kN	0.5 kN	2.0 kN
15	23.87 mm	4.5 kN	0.5 kN	2.0 kN
16	25.46 mm	4.5 kN	0.6 kN	2.5 kN
17	27.06 mm	5.0 kN	0.6 kN	2.5 kN
18	28.65 mm	5.0 kN	0.6 kN	2.5 kN
19	30.24 mm	5.5 kN	0.7 kN	3.0 kN
20	31.83 mm	6.0 kN	0.7 kN	3.0 kN
21	33.42 mm	6.0 kN	0.8 kN	3.0 kN
22	35.01 mm	6.5 kN	0.8 kN	3.5 kN
23	36.61 mm	7.0 kN	0.8 kN	3.5 kN
24	38.20 mm	7.0 kN	0.9 kN	3.5 kN
25	39.79 mm	7.5 kN	0.9 kN	3.5 kN
26	41.38 mm	8.0 kN	1.0 kN	3.5 kN
27	42.97 mm	8.0 kN	1.0 kN	3.5 kN
28	44.56 mm	8.5 kN	1.0 kN	3.5 kN
29	46.16 mm	9.0 kN	1.0 kN	3.5 kN
30	47.75 mm	9.0 kN	1.0 kN	3.5 kN
31	49.34 mm	9.0 kN	1.0 kN	3.5 kN
32	50.93 mm	9.0 kN	1.0 kN	3.5 kN
33	52.52 mm	9.0 kN	1.0 kN	3.5 kN
34	54.11 mm	9.0 kN	1.0 kN	3.5 kN
35	55.70 mm	9.0 kN	1.0 kN	3.5 kN
36	57.30 mm	9.0 kN	1.0 kN	3.5 kN
37	58.89 mm	9.0 kN	1.0 kN	3.5 kN
38	60.48 mm	9.0 kN	1.0 kN	3.5 kN
39	62.07 mm	9.0 kN	1.5 kN	3.5 kN
40	63.66 mm	9.0 kN	1.5 kN	3.5 kN

Maximum permissible Feed Forces ¹⁾ in kN

which are achieved with good grease lubrication (i.e. use of the electronic lubricator described on page ZE-2/3 or manual lubrication at least once a day) and $v=1.5$ m/s, $S_B=1.0$ as well as a linear load distribution factor of 1.0.

The values in the load tables are maximum values under perfect conditions and is a guide value.

A calculation of the application and configuration is in any cases needed.

Calculation and example see page ZD-2.

1) For keyway transmission make a separate calculation, torque with shrink disk see on page GH-1.

When using the maximum capacity of the teeth, or multiple pinions in contact, the mounting screw loads must be checked separately!

1) Check availability (chapter ZA)



ATLANTA

Rack and Pinion Drive – Calculation and Selection – Module 2 – Helical Tooth System

Rack		UHPR	HPR			PR			BR			
Quality		5	6		7	8			9		10	
Rack	Material	16MnCr5	16MnCr5	C45	C45	C45	42CrMo4		C45		C45	
	Heat Treatment	Case Hardened	Induction Hardened		Ind. Hardened	Ind. Hardened	Quenched + Tempered		Soft		Induction Hardened	
Pinion	Material	16MnCr5	16MnCr5	16MnCr5	16MnCr5	16MnCr5	16MnCr5	C45	16MnCr5	C45	16MnCr5	C45
	Heat Treatment	Case Hardened	Case Hardened	Case Hardened	Case Hardened	Case Hardened	Case Hardened	Ind. Hardened	Case Hardened	Soft	Case Hardened	Ind. Hardened
No. of Pinion Teeth ¹⁾	Pitch Circle Dia.	Maximum Feed Force										
12	25.46 mm	8.5 kN	8.0 kN	6.0 kN	6.0 kN	5.0 kN	2.0 kN	1.0 kN	1.0 kN	0.6 kN	3.5 kN	2.5 kN
13	27.59 mm	9.0 kN	8.5 kN	6.0 kN	6.0 kN	5.5 kN	2.0 kN	1.0 kN	1.0 kN	0.6 kN	4.0 kN	2.5 kN
14	29.71 mm	10.5 kN	10.0 kN	7.5 kN	7.5 kN	6.5 kN	2.5 kN	1.5 kN	1.0 kN	0.7 kN	4.5 kN	3.0 kN
15	31.83 mm	12.0 kN	11.0 kN	8.0 kN	8.0 kN	7.0 kN	2.5 kN	1.5 kN	1.5 kN	0.8 kN	5.0 kN	3.5 kN
16	33.95 mm	13.0 kN	12.0 kN	9.0 kN	9.0 kN	7.5 kN	3.0 kN	2.0 kN	1.5 kN	0.9 kN	5.5 kN	3.5 kN
17	36.08 mm	13.5 kN	13.0 kN	9.5 kN	9.5 kN	8.0 kN	3.0 kN	2.0 kN	1.5 kN	1.0 kN	6.0 kN	4.0 kN
18	38.20 mm	14.5 kN	13.5 kN	10.0 kN	10.0 kN	8.5 kN	3.5 kN	2.0 kN	1.5 kN	1.0 kN	6.5 kN	4.0 kN
19	40.32 mm	15.5 kN	14.5 kN	10.5 kN	10.5 kN	9.0 kN	3.5 kN	2.0 kN	2.0 kN	1.0 kN	7.0 kN	4.5 kN
20	42.44 mm	16.5 kN	15.5 kN	11.5 kN	11.5 kN	9.5 kN	4.0 kN	2.5 kN	2.0 kN	1.0 kN	7.0 kN	4.5 kN
21	44.56 mm	17.0 kN	16.0 kN	12.0 kN	12.0 kN	10.5 kN	4.0 kN	2.5 kN	2.0 kN	1.0 kN	7.5 kN	5.0 kN
22	46.69 mm	18.0 kN	17.0 kN	12.5 kN	12.5 kN	11.0 kN	4.0 kN	2.5 kN	2.0 kN	1.0 kN	8.0 kN	5.5 kN
23	48.81 mm	19.0 kN	17.5 kN	13.0 kN	13.0 kN	11.5 kN	4.5 kN	3.0 kN	2.5 kN	1.0 kN	8.5 kN	5.5 kN
24	50.93 mm	19.5 kN	18.0 kN	13.5 kN	13.5 kN	12.0 kN	4.5 kN	3.0 kN	2.5 kN	1.0 kN	8.5 kN	5.5 kN
25	53.05 mm	20.0 kN	18.5 kN	14.5 kN	14.5 kN	12.5 kN	5.0 kN	3.0 kN	2.5 kN	1.5 kN	9.0 kN	5.5 kN
26	55.17 mm	20.0 kN	18.5 kN	15.0 kN	15.0 kN	13.0 kN	5.0 kN	3.0 kN	2.5 kN	1.5 kN	9.0 kN	5.5 kN
27	57.30 mm	20.0 kN	18.5 kN	15.0 kN	15.0 kN	13.0 kN	5.5 kN	3.5 kN	2.5 kN	1.5 kN	9.0 kN	5.5 kN
28	59.42 mm	20.0 kN	18.5 kN	15.0 kN	15.0 kN	13.0 kN	5.5 kN	3.5 kN	3.0 kN	1.5 kN	9.5 kN	5.5 kN
29	61.54 mm	20.0 kN	18.5 kN	15.0 kN	15.0 kN	13.0 kN	6.0 kN	3.5 kN	3.0 kN	1.5 kN	9.5 kN	5.5 kN
30	63.66 mm	20.0 kN	18.5 kN	15.0 kN	15.0 kN	13.0 kN	6.0 kN	4.0 kN	3.0 kN	1.5 kN	9.5 kN	6.0 kN
31	65.78 mm	20.5 kN	19.0 kN	15.5 kN	15.5 kN	13.0 kN	6.0 kN	4.0 kN	3.0 kN	1.5 kN	9.5 kN	6.0 kN
32	67.91 mm	20.5 kN	19.0 kN	15.5 kN	15.5 kN	13.0 kN	6.5 kN	4.0 kN	3.5 kN	1.5 kN	9.5 kN	6.0 kN
33	70.03 mm	20.5 kN	19.0 kN	15.5 kN	15.5 kN	13.5 kN	6.5 kN	4.0 kN	3.5 kN	2.0 kN	9.5 kN	6.0 kN
34	72.15 mm	20.5 kN	19.0 kN	15.5 kN	15.5 kN	13.5 kN	7.0 kN	4.5 kN	3.5 kN	2.0 kN	9.5 kN	6.0 kN
35	74.27 mm	20.5 kN	19.0 kN	15.5 kN	15.5 kN	13.5 kN	7.0 kN	4.5 kN	3.5 kN	2.0 kN	9.5 kN	6.0 kN
36	76.39 mm	20.5 kN	19.0 kN	15.5 kN	15.5 kN	13.5 kN	7.5 kN	4.5 kN	4.0 kN	2.0 kN	9.5 kN	6.0 kN
37	78.52 mm	20.5 kN	19.0 kN	15.5 kN	15.5 kN	13.5 kN	7.5 kN	5.0 kN	4.0 kN	2.0 kN	9.5 kN	6.0 kN
38	80.64 mm	20.5 kN	19.0 kN	15.5 kN	15.5 kN	13.5 kN	7.5 kN	5.0 kN	4.0 kN	2.0 kN	9.5 kN	6.0 kN
39	82.76 mm	20.5 kN	19.0 kN	15.5 kN	15.5 kN	13.5 kN	8.0 kN	5.0 kN	4.0 kN	2.0 kN	9.5 kN	6.0 kN
40	84.88 mm	20.5 kN	19.5 kN	15.5 kN	15.5 kN	13.5 kN	8.0 kN	5.0 kN	4.0 kN	2.0 kN	9.5 kN	6.0 kN

1) Check availability (chapter ZA)

Maximum permissible feed forces – description see page ZA-30





ATLANTA

Rack and Pinion Drive – Calculation and Selection – Module 3 – Helical Tooth System

Rack		UHPR	HPR			PR			BR			
Quality		5	6		7	8			9		10	
Rack	Material	16MnCr5	16MnCr5	C45	C45	C45	42CrMo4		C45		C45	
	Heat Treatment	Case Hardened	Induction Hardened		Ind. Hardened	Ind. Hardened	Quenched + Tempered		Soft		Induction Hardened	
Pinion	Material	16MnCr5	16MnCr5	16MnCr5	16MnCr5	16MnCr5	16MnCr5	C45	16MnCr5	C45	16MnCr5	C45
	Heat Treatment	Case Hardened	Case Hardened	Case Hardened	Case Hardened	Case Hardened	Case Hardened	Ind. Hardened	Case Hardened	Soft	Case Hardened	Ind. Hardened
No. of Pinion Teeth ¹⁾	Pitch Circle Dia.	Maximum Feed Force										
12	38.20 mm	13.5 kN	13.0 kN	9.5 kN	9.5 kN	8.0 kN	3.0 kN	2.5 kN	1.5 kN	1.0 kN	5.5 kN	5.0 kN
13	41.38 mm	16.0 kN	15.0 kN	11.0 kN	11.0 kN	9.0 kN	3.5 kN	3.0 kN	1.5 kN	1.5 kN	6.5 kN	6.0 kN
14	44.56 mm	19.0 kN	18.0 kN	13.0 kN	13.0 kN	11.0 kN	4.5 kN	3.5 kN	2.0 kN	1.5 kN	8.0 kN	7.5 kN
15	47.75 mm	21.0 kN	19.5 kN	14.5 kN	14.5 kN	12.0 kN	5.0 kN	4.0 kN	2.5 kN	2.0 kN	9.0 kN	8.0 kN
16	50.93 mm	22.5 kN	21.0 kN	15.5 kN	15.5 kN	13.0 kN	5.0 kN	4.5 kN	2.5 kN	2.0 kN	9.5 kN	8.5 kN
17	54.11 mm	24.0 kN	22.5 kN	16.5 kN	16.5 kN	14.0 kN	5.5 kN	4.5 kN	2.5 kN	2.0 kN	10.0 kN	9.0 kN
18	57.30 mm	25.5 kN	24.0 kN	17.5 kN	17.5 kN	14.5 kN	6.0 kN	5.0 kN	3.0 kN	2.0 kN	11.0 kN	10.0 kN
19	60.48 mm	27.0 kN	25.5 kN	19.0 kN	19.0 kN	15.5 kN	6.0 kN	5.5 kN	3.0 kN	2.5 kN	11.5 kN	10.5 kN
20	63.66 mm	28.5 kN	27.0 kN	20.0 kN	20.0 kN	16.5 kN	6.5 kN	5.5 kN	3.0 kN	2.5 kN	12.0 kN	11.0 kN
21	66.85 mm	29.0 kN	28.5 kN	21.0 kN	21.0 kN	17.5 kN	7.0 kN	6.0 kN	3.5 kN	2.5 kN	13.0 kN	11.5 kN
22	70.03 mm	29.5 kN	29.5 kN	22.0 kN	22.0 kN	18.5 kN	7.5 kN	6.5 kN	3.5 kN	2.5 kN	13.5 kN	12.0 kN
23	73.21 mm	29.5 kN	29.5 kN	23.0 kN	23.0 kN	19.0 kN	7.5 kN	6.5 kN	4.0 kN	3.0 kN	14.0 kN	13.0 kN
24	76.39 mm	29.5 kN	29.5 kN	24.0 kN	24.0 kN	20.0 kN	8.0 kN	7.0 kN	4.0 kN	3.0 kN	15.0 kN	13.0 kN
25	79.58 mm	30.0 kN	30.0 kN	25.5 kN	25.0 kN	21.0 kN	8.5 kN	7.5 kN	4.0 kN	3.0 kN	15.5 kN	13.0 kN
26	82.76 mm	30.0 kN	30.0 kN	26.5 kN	26.5 kN	22.0 kN	8.5 kN	7.5 kN	4.5 kN	3.5 kN	16.0 kN	13.0 kN
27	85.94 mm	30.0 kN	30.0 kN	27.5 kN	27.5 kN	22.5 kN	9.0 kN	8.0 kN	4.5 kN	3.5 kN	17.0 kN	13.5 kN
28	89.13 mm	30.5 kN	30.5 kN	27.5 kN	27.5 kN	23.5 kN	9.5 kN	8.0 kN	4.5 kN	3.5 kN	17.0 kN	13.5 kN
29	92.31 mm	30.5 kN	30.5 kN	27.5 kN	27.5 kN	23.5 kN	10.0 kN	8.5 kN	5.0 kN	4.0 kN	17.0 kN	13.5 kN
30	95.49 mm	30.5 kN	30.5 kN	27.5 kN	27.5 kN	24.0 kN	10.0 kN	9.0 kN	5.0 kN	4.0 kN	17.5 kN	13.5 kN
31	98.68 mm	30.5 kN	30.5 kN	28.0 kN	28.0 kN	24.0 kN	10.5 kN	9.0 kN	5.5 kN	4.0 kN	17.5 kN	13.5 kN
32	101.86 mm	31.0 kN	30.5 kN	28.0 kN	28.0 kN	24.0 kN	11.0 kN	9.5 kN	5.5 kN	4.0 kN	17.5 kN	13.5 kN
33	105.04 mm	31.0 kN	31.0 kN	28.0 kN	28.0 kN	24.0 kN	11.5 kN	10.0 kN	5.5 kN	4.5 kN	17.5 kN	13.5 kN
34	108.23 mm	31.0 kN	31.0 kN	28.0 kN	28.0 kN	24.0 kN	11.5 kN	10.0 kN	6.0 kN	4.5 kN	17.5 kN	13.5 kN
35	111.41 mm	31.0 kN	31.0 kN	28.0 kN	28.0 kN	24.0 kN	12.0 kN	10.5 kN	6.0 kN	4.5 kN	17.5 kN	13.5 kN
36	114.59 mm	31.0 kN	31.0 kN	28.5 kN	28.5 kN	24.5 kN	12.5 kN	11.0 kN	6.0 kN	5.0 kN	17.5 kN	13.5 kN
37	117.77 mm	31.0 kN	31.0 kN	28.5 kN	28.5 kN	24.5 kN	13.0 kN	11.0 kN	6.5 kN	5.0 kN	17.5 kN	13.5 kN
38	120.96 mm	31.0 kN	31.0 kN	28.5 kN	28.5 kN	24.5 kN	13.0 kN	11.5 kN	6.5 kN	5.0 kN	17.5 kN	13.5 kN
39	124.14 mm	31.0 kN	31.0 kN	28.5 kN	28.5 kN	24.5 kN	13.5 kN	11.5 kN	7.0 kN	5.0 kN	17.5 kN	13.5 kN
40	127.32 mm	31.0 kN	31.0 kN	28.5 kN	28.5 kN	24.5 kN	14.0 kN	12.0 kN	7.0 kN	5.5 kN	17.5 kN	13.5 kN

1) Check availability (chapter ZA)

Maximum permissible feed forces – description see page ZA-30



ATLANTA

Rack and Pinion Drive – Calculation and Selection – Module 4 – Helical Tooth System

Rack		UHPR	HPR			PR			BR			
Quality		5	6		7	8			9		10	
Rack	Material	16MnCr5	16MnCr5	C45	C45	C45	42CrMo4		C45		C45	
	Heat Treatment	Case Hardened	Induction Hardened		Ind. Hardened	Ind. Hardened	Quenched + Tempered		Soft		Induction Hardened	
Pinion	Material	16MnCr5	16MnCr5	16MnCr5	16MnCr5	16MnCr5	16MnCr5	C45	16MnCr5	C45	16MnCr5	C45
	Heat Treatment	Case Hardened	Case Hardened	Case Hardened	Case Hardened	Case Hardened	Case Hardened	Ind. Hardened	Case Hardened	Soft	Case Hardened	Ind. Hardened
No. of Pinion Teeth ¹⁾	Pitch Circle Dia.	Maximum Feed Force										
12	50.93 mm	25.5 kN	24.0 kN	18.0 kN	17.5 kN	15.0 kN	6.0 kN	5.0 kN	3.0 kN	2.0 kN	11.0 kN	9.5 kN
13	55.17 mm	30.0 kN	28.0 kN	20.5 kN	20.5 kN	17.5 kN	7.0 kN	5.5 kN	3.5 kN	2.5 kN	13.0 kN	11.0 kN
14	59.42 mm	34.5 kN	32.5 kN	24.0 kN	24.0 kN	20.5 kN	8.0 kN	6.5 kN	4.0 kN	3.0 kN	15.0 kN	12.5 kN
15	63.66 mm	39.5 kN	37.0 kN	27.5 kN	27.5 kN	23.5 kN	9.5 kN	7.5 kN	4.5 kN	3.5 kN	17.0 kN	14.5 kN
16	67.91 mm	42.5 kN	39.5 kN	29.5 kN	29.5 kN	25.0 kN	10.0 kN	8.0 kN	5.0 kN	3.5 kN	18.5 kN	15.5 kN
17	72.15 mm	45.0 kN	42.0 kN	31.5 kN	31.0 kN	26.5 kN	10.5 kN	8.5 kN	5.5 kN	4.0 kN	19.5 kN	16.5 kN
18	76.39 mm	48.0 kN	45.0 kN	33.5 kN	33.0 kN	28.5 kN	11.5 kN	9.0 kN	5.5 kN	4.0 kN	21.0 kN	17.5 kN
19	80.64 mm	51.0 kN	47.5 kN	35.5 kN	35.0 kN	30.0 kN	12.0 kN	10.0 kN	6.0 kN	4.5 kN	22.5 kN	19.0 kN
20	84.88 mm	54.0 kN	50.0 kN	37.0 kN	37.0 kN	31.5 kN	13.0 kN	10.5 kN	6.5 kN	4.5 kN	23.5 kN	20.0 kN
21	89.13 mm	55.5 kN	53.0 kN	39.0 kN	39.0 kN	33.5 kN	13.5 kN	11.0 kN	7.0 kN	5.0 kN	25.0 kN	21.0 kN
22	93.37 mm	56.0 kN	55.5 kN	41.0 kN	41.0 kN	35.0 kN	14.0 kN	11.5 kN	7.0 kN	5.0 kN	26.0 kN	22.0 kN
23	97.62 mm	56.5 kN	56.5 kN	43.0 kN	43.0 kN	37.0 kN	15.0 kN	12.0 kN	7.5 kN	5.5 kN	27.5 kN	23.0 kN
24	101.86 mm	57.0 kN	57.0 kN	45.0 kN	45.0 kN	38.5 kN	15.5 kN	12.5 kN	8.0 kN	5.5 kN	28.5 kN	23.5 kN
25	106.10 mm	57.5 kN	57.5 kN	47.0 kN	47.0 kN	40.0 kN	16.0 kN	13.0 kN	8.0 kN	6.0 kN	30.0 kN	23.5 kN
26	110.35 mm	58.0 kN	57.5 kN	49.0 kN	49.0 kN	42.0 kN	17.0 kN	13.5 kN	8.5 kN	6.0 kN	30.5 kN	24.0 kN
27	114.59 mm	58.0 kN	58.0 kN	49.5 kN	49.5 kN	42.0 kN	17.5 kN	14.5 kN	9.0 kN	6.5 kN	31.0 kN	24.0 kN
28	118.84 mm	58.5 kN	58.5 kN	49.5 kN	49.5 kN	42.0 kN	18.5 kN	15.0 kN	9.5 kN	6.5 kN	31.0 kN	24.0 kN
29	123.08 mm	58.5 kN	58.5 kN	50.0 kN	50.0 kN	42.5 kN	19.0 kN	15.5 kN	9.5 kN	7.0 kN	31.0 kN	24.0 kN
30	127.32 mm	58.5 kN	58.5 kN	50.0 kN	50.0 kN	42.5 kN	19.5 kN	16.0 kN	10.0 kN	7.0 kN	31.0 kN	24.0 kN
31	131.57 mm	59.0 kN	59.0 kN	50.0 kN	50.0 kN	42.5 kN	20.5 kN	16.5 kN	10.5 kN	7.5 kN	31.0 kN	24.5 kN
32	135.81 mm	59.0 kN	59.0 kN	50.5 kN	50.5 kN	43.0 kN	21.0 kN	17.0 kN	11.0 kN	7.5 kN	31.5 kN	24.5 kN
33	140.06 mm	59.0 kN	59.0 kN	50.5 kN	50.5 kN	43.0 kN	22.0 kN	17.5 kN	11.0 kN	8.0 kN	31.5 kN	24.5 kN
34	144.30 mm	59.5 kN	59.5 kN	50.5 kN	50.5 kN	43.0 kN	22.5 kN	18.0 kN	11.5 kN	8.0 kN	31.5 kN	24.5 kN
35	148.54 mm	59.5 kN	59.5 kN	51.0 kN	51.0 kN	43.5 kN	23.0 kN	19.0 kN	12.0 kN	8.5 kN	31.5 kN	24.5 kN
36	152.79 mm	59.5 kN	59.5 kN	51.0 kN	51.0 kN	43.5 kN	24.0 kN	19.5 kN	12.0 kN	8.5 kN	31.5 kN	24.5 kN
37	157.03 mm	59.5 kN	59.5 kN	51.0 kN	51.0 kN	43.5 kN	24.5 kN	20.0 kN	12.5 kN	9.0 kN	31.5 kN	24.5 kN
38	161.28 mm	59.5 kN	59.5 kN	51.5 kN	51.5 kN	43.5 kN	25.5 kN	20.5 kN	13.0 kN	9.0 kN	32.0 kN	24.5 kN
39	165.52 mm	60.0 kN	59.5 kN	51.5 kN	51.5 kN	43.5 kN	26.0 kN	21.0 kN	13.5 kN	9.5 kN	32.0 kN	24.5 kN
40	169.77 mm	60.0 kN	60.0 kN	51.5 kN	51.5 kN	44.0 kN	27.0 kN	21.5 kN	13.5 kN	10.0 kN	32.0 kN	24.5 kN

1) Check availability (chapter ZA)

Maximum permissible feed forces – description see page ZA-30





ATLANTA

Rack and Pinion Drive – Calculation and Selection – Module 5 – Helical Tooth System

Rack		UHPR		HPR		PR			BR			
Quality		4	5	6	7	8			9	10		
Rack	Material	C45	16MnCr5	C45	C45	C45	42CrMo4		C45		C45	
	Heat Treatment	Ind. Hardened	Case Hardened	Induction Hardened		Ind. Hardened	Quenched + Tempered		Soft		Induction Hardened	
Pinion	Material	16MnCr5	16MnCr5	16MnCr5	16MnCr5	16MnCr5	16MnCr5	C45	16MnCr5	C45	16MnCr5	C45
	Heat Treatment	Case Hardened	Case Hardened	Case Hardened	Case Hardened	Case Hardened	Case Hardened	Ind. Hardened	Case Hardened	Soft	Case Hardened	Ind. Hardened
No. of Pinion Teeth ¹⁾	Pitch Circle Dia.	Maximum Feed Force										
12	63.66 mm	28.0 kN	40.5 kN	28.0 kN	28.0 kN	23.5 kN	9.5 kN	7.5 kN	5.0 kN	3.5 kN	17.5 kN	15.0 kN
13	68.97 mm	32.5 kN	47.0 kN	32.5 kN	32.5 kN	27.5 kN	11.0 kN	9.0 kN	5.5 kN	4.0 kN	20.5 kN	17.5 kN
14	74.27 mm	37.5 kN	54.5 kN	37.5 kN	37.5 kN	32.0 kN	13.0 kN	10.5 kN	6.5 kN	4.5 kN	23.5 kN	20.0 kN
15	79.58 mm	43.0 kN	62.0 kN	43.0 kN	43.0 kN	36.5 kN	14.5 kN	12.0 kN	7.5 kN	5.5 kN	27.0 kN	23.0 kN
16	84.88 mm	46.0 kN	66.5 kN	46.0 kN	46.0 kN	39.0 kN	16.0 kN	13.0 kN	8.0 kN	5.5 kN	29.0 kN	24.5 kN
17	90.19 mm	49.5 kN	71.0 kN	49.5 kN	49.5 kN	42.0 kN	17.0 kN	13.5 kN	8.5 kN	6.0 kN	31.0 kN	26.0 kN
18	95.49 mm	52.5 kN	75.5 kN	52.5 kN	52.5 kN	44.5 kN	18.0 kN	14.5 kN	9.0 kN	6.5 kN	33.0 kN	28.0 kN
19	100.80 mm	55.5 kN	80.0 kN	55.5 kN	55.5 kN	47.0 kN	19.0 kN	15.5 kN	9.5 kN	7.0 kN	35.0 kN	29.5 kN
20	106.10 mm	58.5 kN	84.5 kN	58.5 kN	58.5 kN	49.5 kN	20.0 kN	16.5 kN	10.5 kN	7.5 kN	37.0 kN	31.0 kN
21	111.41 mm	62.0 kN	87.0 kN	61.5 kN	61.5 kN	52.5 kN	21.0 kN	17.0 kN	11.0 kN	7.5 kN	39.0 kN	33.0 kN
22	116.71 mm	65.0 kN	88.0 kN	65.0 kN	65.0 kN	55.0 kN	22.5 kN	18.0 kN	11.5 kN	8.0 kN	41.0 kN	34.5 kN
23	122.02 mm	68.0 kN	88.5 kN	68.0 kN	68.0 kN	57.5 kN	23.5 kN	19.0 kN	12.0 kN	8.5 kN	43.0 kN	36.5 kN
24	127.32 mm	71.0 kN	89.5 kN	71.0 kN	71.0 kN	60.5 kN	24.5 kN	20.0 kN	12.5 kN	9.0 kN	45.0 kN	37.0 kN
25	132.63 mm	74.5 kN	90.0 kN	74.5 kN	74.5 kN	63.0 kN	25.5 kN	20.5 kN	13.0 kN	9.5 kN	47.0 kN	37.0 kN
26	137.93 mm	75.0 kN	90.5 kN	75.0 kN	75.0 kN	63.5 kN	26.5 kN	21.5 kN	13.5 kN	10.0 kN	48.0 kN	37.5 kN
27	143.24 mm	75.5 kN	91.0 kN	75.5 kN	75.5 kN	64.0 kN	27.5 kN	22.5 kN	14.0 kN	10.0 kN	48.0 kN	37.5 kN
28	148.54 mm	75.5 kN	91.0 kN	75.5 kN	75.5 kN	64.0 kN	29.0 kN	23.5 kN	15.0 kN	10.5 kN	48.5 kN	38.0 kN
29	153.85 mm	76.0 kN	91.5 kN	76.0 kN	76.0 kN	64.5 kN	30.0 kN	24.5 kN	15.5 kN	11.0 kN	48.5 kN	38.0 kN
30	159.16 mm	76.5 kN	92.0 kN	76.0 kN	76.0 kN	64.5 kN	31.0 kN	25.0 kN	16.0 kN	11.5 kN	49.0 kN	38.0 kN

1) Check availability (chapter ZA)



ATLANTA

Rack and Pinion Drive – Calculation and Selection – Module 6 – Helical Tooth System

Rack		UHPR	HPR		BR			
Quality		4	6	7	9		10	
Rack	Material	C45	C45	C45	C45		C45	
	Heat Treatment	Ind. Hardened	Induction Hardened		Soft		Induction Hardened	
Pinion	Material	16MnCr5	16MnCr5	16MnCr5	16MnCr5	C45	16MnCr5	C45
	Heat Treatment	Case Hardened	Case Hardened	Case Hardened	Case Hardened	Soft	Case Hardened	Ind. Hardened
No. of Pinion Teeth ¹⁾	Pitch Circle Dia.	Maximum Feed Force						
12	76.39 mm	40.5 kN	40.5 kN	40.5 kN	7.0 kN	5.0 kN	25.5 kN	21.5 kN
13	82.76 mm	47.5 kN	47.0 kN	47.0 kN	8.0 kN	6.0 kN	29.5 kN	25.0 kN
14	89.13 mm	54.5 kN	54.5 kN	54.5 kN	9.5 kN	7.0 kN	34.5 kN	29.0 kN
15	95.49 mm	62.5 kN	62.5 kN	62.5 kN	11.0 kN	8.0 kN	39.0 kN	33.0 kN
16	101.86 mm	67.0 kN	67.0 kN	67.0 kN	11.5 kN	8.5 kN	42.0 kN	35.5 kN
17	108.23 mm	71.5 kN	71.5 kN	71.5 kN	12.5 kN	9.0 kN	45.0 kN	38.0 kN
18	114.59 mm	76.0 kN	76.0 kN	76.0 kN	13.5 kN	9.5 kN	47.5 kN	40.5 kN
19	120.96 mm	80.5 kN	80.5 kN	80.5 kN	14.0 kN	10.0 kN	50.5 kN	43.0 kN
20	127.32 mm	85.0 kN	85.0 kN	85.0 kN	15.0 kN	10.5 kN	53.5 kN	45.0 kN
21	133.69 mm	89.5 kN	89.5 kN	89.5 kN	15.5 kN	11.5 kN	56.5 kN	47.5 kN
22	140.06 mm	94.0 kN	94.0 kN	94.0 kN	16.5 kN	12.0 kN	59.0 kN	50.0 kN
23	146.42 mm	98.5 kN	98.5 kN	98.5 kN	17.5 kN	12.5 kN	62.0 kN	52.5 kN
24	152.79 mm	103.0 kN	103.0 kN	103.0 kN	18.0 kN	13.0 kN	65.0 kN	53.0 kN
25	159.16 mm	107.0 kN	107.0 kN	107.0 kN	19.0 kN	13.5 kN	66.5 kN	53.5 kN
26	165.52 mm	107.5 kN	107.5 kN	107.5 kN	20.0 kN	14.0 kN	66.5 kN	53.5 kN
27	171.89 mm	108.0 kN	108.0 kN	108.0 kN	20.5 kN	15.0 kN	67.0 kN	54.0 kN
28	178.25 mm	108.5 kN	108.0 kN	108.0 kN	21.5 kN	15.5 kN	67.0 kN	54.0 kN
29	184.62 mm	109.0 kN	108.5 kN	108.5 kN	22.0 kN	16.0 kN	67.5 kN	54.5 kN
30	190.99 mm	109.0 kN	109.0 kN	109.0 kN	23.0 kN	16.5 kN	67.5 kN	54.5 kN

1) Check availability (chapter ZA)

Maximum permissible feed forces – description see page ZA-30



ATLANTA
Rack and Pinion Drive – Calculation and Selection – Module 8 – Helical Tooth System

Rack		UHPR	HPR			BR		
Quality		4	6	7	9	10		
Rack	Material	C45	C45	C45	C45		C45	
	Heat Treatment	Ind. Hardened	Induction Hardened			Soft		Induction Hardened
Pinion	Material	16MnCr5	16MnCr5	16MnCr5	16MnCr5	C45	16MnCr5	C45
	Heat Treatment	Case Hardened	Case Hardened	Case Hardened	Case Hardened	Soft	Case Hardened	Ind. Hardened
No. of Pinion Teeth ¹⁾	Pitch Circle Dia.	Maximum Feed Force						
12	101.86 mm	73.0 kN	72.5 kN	72.5 kN	12.5 kN	9.0 kN	45.5 kN	38.5 kN
13	110.35 mm	84.5 kN	84.5 kN	84.5 kN	15.0 kN	10.5 kN	53.0 kN	44.5 kN
14	118.84 mm	98.0 kN	97.5 kN	97.5 kN	17.0 kN	12.5 kN	61.5 kN	52.0 kN
15	127.32 mm	111.5 kN	111.5 kN	111.5 kN	19.5 kN	14.0 kN	70.0 kN	59.5 kN
16	135.81 mm	119.5 kN	119.5 kN	119.5 kN	21.0 kN	15.0 kN	75.0 kN	63.5 kN
17	144.30 mm	127.5 kN	127.5 kN	127.5 kN	22.5 kN	16.0 kN	80.0 kN	67.5 kN
18	152.79 mm	135.5 kN	135.5 kN	135.5 kN	24.0 kN	17.0 kN	85.0 kN	72.0 kN
19	161.28 mm	143.5 kN	143.5 kN	143.5 kN	25.5 kN	18.0 kN	90.0 kN	76.5 kN
20	169.77 mm	151.5 kN	151.5 kN	151.5 kN	27.0 kN	19.5 kN	95.5 kN	80.5 kN
21	178.25 mm	160.0 kN	160.0 kN	159.5 kN	28.5 kN	20.5 kN	100.5 kN	85.0 kN
22	186.74 mm	168.0 kN	168.0 kN	167.5 kN	29.5 kN	21.5 kN	105.5 kN	89.0 kN
23	195.23 mm	176.0 kN	176.0 kN	176.0 kN	31.0 kN	22.5 kN	110.5 kN	92.5 kN
24	203.72 mm	184.0 kN	184.0 kN	184.0 kN	32.5 kN	23.5 kN	115.5 kN	93.0 kN
25	212.21 mm	187.0 kN	187.0 kN	187.0 kN	34.0 kN	24.5 kN	116.5 kN	93.5 kN
26	220.70 mm	188.0 kN	188.0 kN	188.0 kN	35.5 kN	25.5 kN	117.0 kN	94.0 kN
27	229.18 mm	189.0 kN	189.0 kN	188.5 kN	37.0 kN	26.5 kN	117.5 kN	94.5 kN
28	237.67 mm	189.5 kN	189.5 kN	189.5 kN	38.5 kN	27.5 kN	117.5 kN	95.0 kN
29	246.16 mm	190.5 kN	190.5 kN	190.5 kN	40.0 kN	28.5 kN	118.0 kN	95.0 kN
30	254.65 mm	191.0 kN	191.0 kN	191.0 kN	41.5 kN	29.5 kN	118.5 kN	95.5 kN

1) Check availability (chapter ZA)

Maximum permissible feed forces – description see page ZA-30



ATLANTA
Rack and Pinion Drive – Calculation and Selection – Module 10 – Helical Tooth System

Rack		UHPR	HPR		BR			
Quality		4	6	7	9	10		
Rack	Material	C45	C45	C45	C45		C45	
	Heat Treatment	Ind. Hardened	Induction Hardened		Soft		Induction Hardened	
Pinion	Material	16MnCr5	16MnCr5	16MnCr5	16MnCr5	C45	16MnCr5	C45
	Heat Treatment	Case Hardened	Case Hardened	Case Hardened	Case Hardened	Soft	Case Hardened	Ind. Hardened
No. of Pinion Teeth ¹⁾	Pitch Circle Dia.	Maximum Feed Force						
12	127.32 mm	114.5 kN	114.0 kN	114.0 kN	20.0 kN	14.5 kN	71.5 kN	60.5 kN
13	137.93 mm	132.5 kN	132.5 kN	132.5 kN	23.5 kN	16.5 kN	83.0 kN	70.0 kN
14	148.54 mm	153.5 kN	153.5 kN	153.5 kN	27.0 kN	19.5 kN	96.0 kN	81.5 kN
15	159.16 mm	175.0 kN	175.0 kN	175.0 kN	31.0 kN	22.0 kN	109.5 kN	93.0 kN
16	169.77 mm	187.5 kN	187.5 kN	187.5 kN	33.0 kN	24.0 kN	117.5 kN	99.5 kN
17	180.38 mm	200.0 kN	200.0 kN	200.0 kN	35.5 kN	25.5 kN	125.5 kN	106.0 kN
18	190.99 mm	212.5 kN	212.5 kN	212.5 kN	37.5 kN	27.0 kN	133.5 kN	113.0 kN
19	201.60 mm	225.5 kN	225.5 kN	225.0 kN	40.0 kN	28.5 kN	141.5 kN	119.5 kN
20	212.21 mm	238.0 kN	238.0 kN	237.5 kN	42.0 kN	30.5 kN	149.5 kN	126.0 kN
21	222.82 mm	250.5 kN	250.5 kN	250.5 kN	44.5 kN	32.0 kN	157.0 kN	133.0 kN
22	233.43 mm	263.0 kN	263.0 kN	263.0 kN	46.5 kN	33.5 kN	165.0 kN	140.0 kN
23	244.04 mm	276.0 kN	276.0 kN	276.0 kN	49.0 kN	35.0 kN	173.0 kN	142.0 kN
24	254.65 mm	286.0 kN	285.5 kN	285.5 kN	51.0 kN	37.0 kN	178.0 kN	143.0 kN
25	265.26 mm	287.5 kN	287.0 kN	287.0 kN	53.5 kN	38.5 kN	178.5 kN	143.5 kN

1) Check availability (chapter ZA)

Maximum permissible feed forces – description see page ZA-30

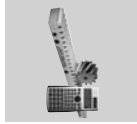

ATLANTA
Rack and Pinion Drive – Calculation and Selection – Module 12 – Helical Tooth System

Rack		UHPR	HPR	BR	
Quality		4	6	10	
Rack	Material	C45	C45	C45	
	Heat Treatment	Ind. Hardened	Ind. Hardened	Induction Hardened	
Pinion	Material	16MnCr5	16MnCr5	16MnCr5	C45
	Heat Treatment	Case Hardened	Case Hardened	Case Hardened	Ind. Hardened
No. of Pinion Teeth ¹⁾	Pitch Circle Dia.	Maximum Feed Force			
12	152.79 mm	163.0 kN	163.0 kN	101.0 kN	85.5 kN
13	165.52 mm	189.5 kN	189.5 kN	117.5 kN	99.0 kN
14	178.25 mm	219.0 kN	219.0 kN	136.0 kN	115.0 kN
15	190.99 mm	249.5 kN	249.5 kN	155.0 kN	131.0 kN
16	203.72 mm	267.5 kN	267.0 kN	166.0 kN	140.5 kN
17	216.45 mm	285.5 kN	285.5 kN	177.0 kN	150.0 kN
18	229.18 mm	303.0 kN	303.0 kN	188.5 kN	159.5 kN
19	241.92 mm	321.5 kN	321.0 kN	199.5 kN	169.0 kN
20	254.65 mm	339.5 kN	339.0 kN	210.5 kN	178.5 kN
21	267.38 mm	357.5 kN	357.0 kN	222.0 kN	187.5 kN
22	280.11 mm	375.5 kN	375.0 kN	233.0 kN	197.5 kN
23	292.85 mm	394.0 kN	393.5 kN	244.5 kN	200.0 kN
24	305.58 mm	407.5 kN	407.5 kN	251.0 kN	201.5 kN
25	318.31 mm	409.0 kN	409.0 kN	252.5 kN	202.5 kN

1) Check availability (chapter ZA)

Maximum permissible feed forces – description see page ZA-30



Class	ATLANTA Quality	Module	Total Pitch Error ¹⁾ (± μm/m)	Tooth Thickness Tolerance (μm)	Max. Length (mm)	Max. Feed Force per Pinion Contact ²⁾ (kN)	Applications (Examples)	
UHPR Ultra High Precision Rack	3	5	12	-13	1005	62.0	High Precision Machine Tools with Electrical Preload	
		6	12	-13	1018	89.0		
		8	12	-13	1005	156.0		
		10	12	-13	1005	234.0		
		12	12	-13	1018	333.5		
HPR High Precision Rack	5	3	26	-15	1018	25.5	Backlash Free Drives with Electrical Preload Machine Tools, Lifting Axis, Multiple Pinion Contact	
		4	26	-15	1005	49.0		
		5	26	-15	1005	75.0		
		6	26	-15	1018	107.0		
HPR High Precision Rack	6	2	34	-20	1005	15.5	Wood, Plastic, Composite, Aluminium Working Machines	
		3	34	-20	1018	25.5		
		4	34	-20	1005	49.0		
	6	2	34	-20	2011	12.5	Machine Tools, Integratable Racks, Water Cutting Machines, Tube Bending Systems, Plasma Cutting Machines	
		3	34	-20	2036	23.5		
		4	34	-20	2011	42.0		
		5	34	-20	2011	62.0		
		6	34	-20	2036	89.0		
		8	34	-20	2011	155.5		
	10	34	-20	1005	234.0			
		12	34	-20	1018	333.0		
		7	2	52	-36	1005	12.5	Woodworking Machines, Linear Axis with High Requirement for a Smooth Running
			3	52	-36	1018	23.0	
4			52	-36	1005	42.0		
5	52		-36	1005	62.0			
6	52		-36	1018	89.0			
8	2	60	-59	1005	12.0	Portals, Handling Linear Axis		
	3	60	-59	1018	22.0			
	4	60	-59	1005	39.0			
	5	60	-59	1005	57.5			
PR Precision Rack	8	2	100	-110	2011	7.0	Linear Axis	
		3	100	-110	2036	12.0		
		4	100	-110	2011	23.0		
BR Basic Rack	9	1	150	-110	999	0.7	Linear Axis with Low Load Feed Units for Adjustment	
		1.5	150	-110	1998	1.0		
		2	150	-110	3016	3.0		
		2.5	150	-110	2003	3.0		
		3	150	-110	3054	6.5		
		4	150	-110	3016	12.5		
		5	150	-110	2011	14.5		
		6	150	-110	2036	21.5		
		8	150	-110	2011	38.5		
	10	150	-110	1005	49.5			
	10	1	200	-110	999	2.0	Driving and Lifting Axes for Higher Loads but Without Special Accuracy	
		1.5	200	-110	1998	3.5		
		2	200	-110	3016	7.0		
3		200	-110	3054	16.5			
4		200	-110	3016	29.5			
5		200	-110	2011	45.5			
6		200	-110	2036	63.0			
8	200	-110	2011	110.0				
10	200	-110	1005	166.0				



¹⁾ Values available for 1000 mm. Other total pitch errors for other length, see detailed description (Kap. ZB).

²⁾ Values are only valid for special steel according ATLANTA-Standard.

When using the maximum capacity of the teeth, or multiple pinions in contact, the mounting screw loads must be checked separately! Please ask ATLANTA for advice!



Class	Series	Module	ATLANTA-Quality	Page
UHPR	46	5, 6, 8, 10, 12	3	ZB-4
	28	3, 4, 5, 6	5	ZB-5
HPR	28	2, 3, 4	6	ZB-6
	28	2, 3, 4, 5, 6, 8, 10, 12	6	ZB-7
	28	2, 3, 4, 5, 6, 8	7	ZB-8
PR	34	2, 3, 4, 5	8	ZB-9
	33	2, 3, 4	8	ZB-10
BR	25	1, 1.5, 2, 2.5, 3, 4, 5, 6, 8, 10	9	ZB-11–12
	34	1, 1.5, 2, 3, 4, 5, 6, 8, 10	10	ZB-15



Selection and Load Tables

ZB-36–46



Electrically Controlled Lubricators, Sliding-Type Lubricating Brushes and Hose-Connection Sets

ZE-2–6



Felt Gear and Mounting Shaft

ZE-7–8









Mounting

ZF-9





	Series	Module	Heat-Treatment of Teeth	Tolerance of Teeth	Page
	78	2, 3, 4, 5, 6, 8	Case-Hardened	≤ 5	ZB-16–20
	24	2, 3, 4, 5, 6, 8, 10	Case-Hardened	6 e 25	ZB-21–26
	24	2, 3, 4, 5	Induction-Hardened	6 e 25	ZB-27
	21/23.. ...	1, 1.5, 2, 2.5, 3, 4, 5, 6, 8, 10, 12	Soft	8 e 25	ZB-28–35
	Short Description TR-Pinion, Mounting Instructions				ZF-11–13
	Selection and Load Tables for Rack Drives				ZD-2–4
	Electronically Controlled Lubricators, Sliding-Type Lubricating Brushes and Hose-Connection Sets				ZE-2–6





ATLANTA-Quality 3

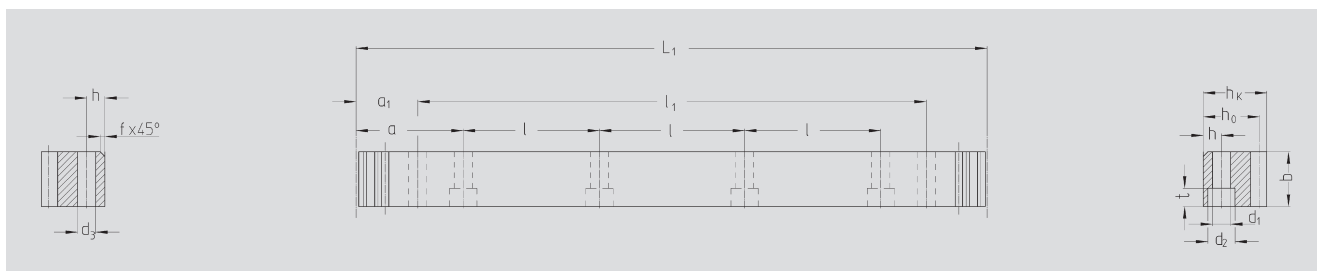

Order Code	Module	L ₁	N° of teeth	b ^{+0,4}	h _k	h ₀	f	a	l	N° of holes	h	d ₁	d ₂	t	a ₁	l ₁	d ₃	kg
46 50 105	5	1005.3	64	49	39	34	2.5	62.8	125.66	8	12	13.5	20	13	30.10	945.0	11.7	12.2
46 60 105	6	1017.9	54	59	49	43	2.5	63.6	127.23	8	16	17.5	26	17	31.40	955.0	15.7	18.5
46 80 105	8	1005.3	40	79	79	71	2.5	62.8	125.66	8	25	22.0	33	21	26.60	952.0	19.7	22.0
46 10 105	10	1005.3	32	99	99	89	2.5	62.8	125.66	8	32	33.0	48	32	125.66	753.9	19.7	68.0
46 12 105	12	1017.9	27	120	120	108	2.5	63.6	127.23	8	40	39.0	58	38	127.23	763.4	19.7	111.0

Total pitch error $GT_f/1000 \leq 0.012 \text{ mm}$

- Teeth hardened with the ATLANTA high performance hardening process and ground
- Heat-treatable steel according to ATLANTA-Standard
- Ground on all sides after hardening
- Signed with effective total pitch error (20°C)

Inspection measurement data available as an option.

To achieve precision rack joints, we recommend our patented rack assembly kit, see page ZF-4.

For lubrication of rack & pinions we recommend our automatic lubrication systems, see page ZE-1.

For the calculation and selection of the rack & pinion drive, see page ZD-1.

Screws for rack mounting, see page ZF-3.





ATLANTA-Quality 5

StrongLine

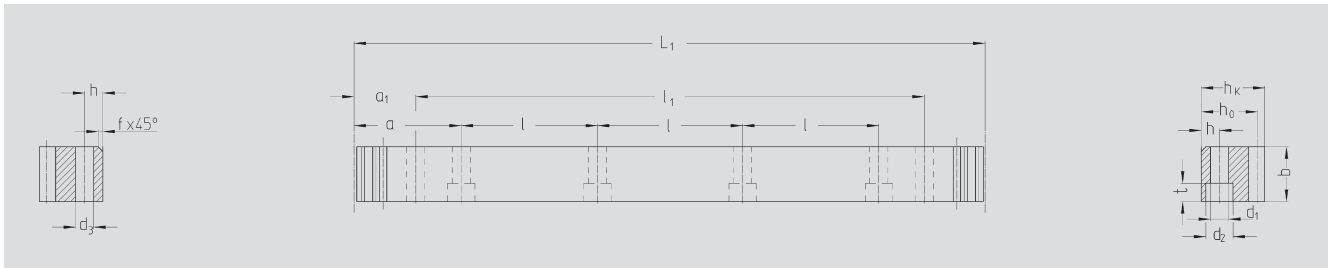

Order Code	Module	L ₁	N° of teeth	b ^{+0,4}	h _k	h ₀	f	a	l	N° of holes	h	d ₁	d ₂	t	a ₁	l ₁	d ₃	kg
28 35 100	3	1017.88	108	29	29	26	2.0	63.61	127.23	8	10	12	17.5	11	28.6	960.6	11.7	5.9
28 45 100	4	1005.31	80	39	39	35	2.0	62.83	125.66	8	13	16	23.0	15	30.3	944.7	15.7	10.7
28 55 100	5	1005.31	64	49	49	44	2.5	62.83	125.66	8	15	18	26.0	17	34.8	935.7	15.7	16.3
28 65 100	6	1017.88	54	59	59	53	2.5	63.62	127.23	8	20	22	33.0	21	98.6	820.6	19.7	24.5

Total pitch error

$$GT_f/1000 \leq 0.026 \text{ mm}$$

- Teeth case hardened and ground
- Case hardening steel according to ATLANTA-Standard
- Ground on all sides after hardening
- Signed with effective total pitch error (20°C)

Inspection measurement data available as an option.

Mounting racks, see page ZF-2.

To achieve precision rack joints, we recommend our patented rack assembly kit, see page ZF-4.

For lubrication of rack & pinions we recommend our automatic lubrication systems, see page ZE-1.

For the calculation and selection of the rack & pinion drive, see page ZD-1.

Screws for rack mounting, see page ZF-3.





ATLANTA-Quality 6

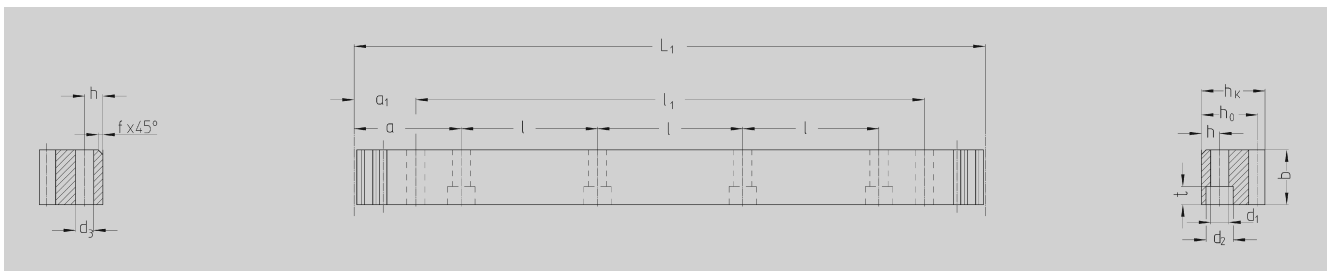

Order Code	Module	L ₁	N° of Teeth	b	h _k	h ₀	f	a	l	N° of Holes	h	d ₁	d ₂	t	a ₁	l ₁	d ₃	kg
28 20 025 ¹⁾	2	251.3	40	24	24	22.0	2	62.8	125.66	2	8	7	11	7	31.3	188.7	5.7	1.00
28 21 025	2	251.3	40	24	24	22.0	2	62.8	125.66	2	8	7	11	7	31.3	188.7	5.7	1.00
28 20 050 ¹⁾	2	502.7	80	24	24	22.0	2	62.8	125.66	4	8	7	11	7	31.3	440.1	5.7	2.10
28 21 050	2	502.7	80	24	24	22.0	2	62.8	125.66	4	8	7	11	7	31.3	440.1	5.7	2.10
28 20 100	2	1005.3	160	24	24	22.0	2	62.8	125.66	8	8	7	11	7	31.3	942.7	5.7	4.20
28 21 100	2	1005.3	160	24	24	22.0	2	62.8	125.66	8	8	7	11	7	31.3	942.7	5.7	4.20
28 30 025 ¹⁾	3	254.5	27	29	29	26.0	2	63.6	127.23	2	9	10	15	9	34.4	185.7	7.7	1.50
28 31 025	3	254.5	27	29	29	26.0	2	63.6	127.23	2	9	10	15	9	34.4	185.7	7.7	1.50
28 30 050 ¹⁾	3	508.9	54	29	29	26.0	2	63.6	127.23	4	9	10	15	9	34.4	440.1	7.7	3.00
28 31 050	3	508.9	54	29	29	26.0	2	63.6	127.23	4	9	10	15	9	34.4	440.1	7.7	3.00
28 30 100	3	1017.9	108	29	29	26.0	2	63.6	127.23	8	9	10	15	9	34.4	949.1	7.7	6.00
28 31 100	3	1017.9	108	29	29	26.0	2	63.6	127.23	8	9	10	15	9	34.4	949.1	7.7	6.00
28 40 025 ¹⁾	4	251.3	20	39	39	35.0	2	62.8	125.66	2	12	10	15	9	37.5	176.3	7.7	2.60
28 41 025	4	251.3	20	39	39	35.0	2	62.8	125.66	2	12	10	15	9	37.5	176.3	7.7	2.60
28 40 050 ¹⁾	4	502.7	40	39	39	35.0	2	62.8	125.66	4	12	10	15	9	37.5	427.7	7.7	5.30
28 41 050	4	502.7	40	39	39	35.0	2	62.8	125.66	4	12	10	15	9	37.5	427.7	7.7	5.30
28 40 100 ¹⁾	4	1005.3	80	39	39	35.0	2	62.8	125.66	8	12	10	15	9	37.5	930.3	7.7	10.50
28 41 100	4	1005.3	80	39	39	35.0	2	62.8	125.66	8	12	10	15	9	37.5	930.3	7.7	10.50
28 42 100	4	1005.3	80	39	39	35.0	2	62.8	125.66	8	12	14	20	13	37.5	930.3	11.7	10.50
28 42 150	4	1507.9	120	39	39	35.0	2	62.8	125.66	12	12	14	20	13	37.5	1432.9	11.7	16.00
28 42 200	4	2010.62	160	39	39	35.0	2	62.8	125.66	16	12	14	20	13	37.5	1935.6	11.7	21.00

1) The screw joint limits the feed force.

Total pitch error:

$GT_f / 500 \leq 0.026 \text{ mm}$

$GT_f / 1000 \leq 0.034 \text{ mm}$

$GT_f / 1500 \leq 0.041 \text{ mm} (\leq 0.027 / 1000 \text{ mm})$

$GT_f / 2000 \leq 0.044 \text{ mm} (\leq 0.022 / 1000 \text{ mm})$

- Teeth induction-hardened and ground
- Material 16MnCr5, carburized
- Ground on all sides after hardening

Mounting racks, see page ZF-2.

Highlighted items will become obsolete in the future. Please check with the factory for delivery information.

To achieve precision rack joints, we recommend our patented rack assembly kit, see page ZF-4.

For lubrication of rack & pinions we recommend our automatic lubrication systems, see page ZE-1.

For the calculation and selection of the rack & pinion drive, see page ZD-1.

Screws for rack mounting, see page ZF-3.



ATLANTA-Quality 6

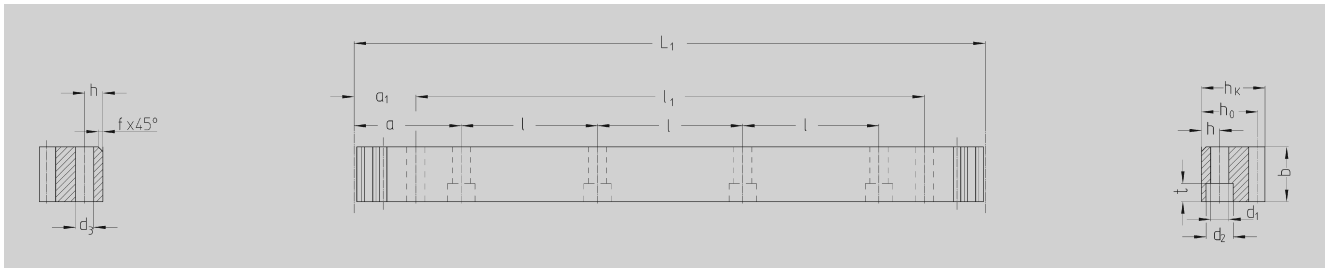

Order Code	Module	L ₁	N° of Teeth	b	h _k	h ₀	f	a	l	N° of Holes	h	d ₁	d ₂	t	a ₁	l ₁	d ₃	kg	
28 20 105	2	1005.30	160	24	24	22.0	2	62.8	125.66	8	8	7	11	7	31.3	942.70	5.7	4.20	
28 21 105	2	1005.30	160	24	24	22.0	2	62.8	125.66	without Mounting Holes									4.20
28 20 205	2	2010.62	320	24	24	22.0	2	62.8	125.66	16	8	7	11	7	31.3	1948.00	5.7	8.40	
28 21 205	2	2010.62	320	24	24	22.0	2	62.8	125.66	without Mounting Holes									8.40
28 30 105	3	1017.90	108	29	29	26.0	2	63.6	127.23	8	9	10	15	9	34.4	949.10	7.7	6.00	
28 31 105	3	1017.90	108	29	29	26.0	2	63.6	127.23	without Mounting Holes									6.00
28 30 205	3	2035.75	216	29	29	26.0	2	63.6	127.23	16	9	10	15	9	34.4	1967.00	7.7	12.00	
28 31 205	3	2035.75	216	29	29	26.0	2	63.6	127.23	without Mounting Holes									12.00
28 40 105 ¹⁾	4	1005.30	80	39	39	35.0	2	62.8	125.66	8	12	10	15	9	37.5	930.30	7.7	10.50	
28 41 105	4	1005.30	80	39	39	35.0	2	62.8	125.66	without Mounting Holes									10.50
28 40 205	4	2010.62	160	39	39	35.0	2	62.8	125.66	16	12	10	15	9	37.5	1935.60	7.7	21.00	
28 41 205	4	2010.62	160	39	39	35.0	2	62.8	125.66	without Mounting Holes									21.00
28 42 105	4	1005.30	80	39	39	35.0	2	62.8	125.66	8	12	14	20	13	37.5	930.3	11.7	10.50	
28 42 155	4	1507.90	120	39	39	35.0	2	62.8	125.66	12	12	14	20	13	37.5	1432.9	11.7	16.00	
28 42 205	4	2010.62	160	39	39	35.0	2	62.8	125.66	16	12	14	20	13	37.5	1935.6	11.7	21.00	
28 50 055 ¹⁾	5	502.60	32	49	39	34	2.5	62.8	125.66	4	12	14	20	13	30.1	442.40	11.7	6.70	
28 51 055	5	502.60	32	49	39	34	2.5	62.8	125.66	without Mounting Holes									6.70
28 50 105	5	1005.30	64	49	39	34	2.5	62.8	125.66	8	12	14	20	13	30.1	945.00	11.7	13.40	
28 51 105	5	1005.30	64	49	39	34	2.5	62.8	125.66	without Mounting Holes									13.40
28 50 155	5	1507.96	96	49	39	34	2.5	62.8	125.66	12	12	14	20	13	30.1	1447.70	11.7	20.10	
28 51 155	5	1507.96	96	49	39	34	2.5	62.8	125.66	without Mounting Holes									20.10
28 50 205	5	2010.62	128	49	39	34	2.5	62.8	125.66	16	12	14	20	13	30.1	1950.40	11.7	26.80	
28 51 205	5	2010.62	128	49	39	34	2.5	62.8	125.66	without Mounting Holes									26.80
28 60 055 ¹⁾	6	508.90	27	59	49	43	2.5	63.6	127.23	4	16	18	26	17	31.4	446.10	15.7	10.40	
28 61 055	6	508.90	27	59	49	43	2.5	63.6	127.23	without Mounting Holes									10.40
28 60 105	6	1017.88	54	59	49	43	2.5	63.6	127.23	8	16	18	26	17	31.4	955.00	15.7	20.20	
28 61 105	6	1017.88	54	59	49	43	2.5	63.6	127.23	without Mounting Holes									20.20
28 60 155	6	1526.81	81	59	49	43	2.5	63.6	127.23	12	16	18	26	17	31.4	1464.00	15.7	30.30	
28 61 155	6	1526.81	81	59	49	43	2.5	63.6	127.23	without Mounting Holes									30.30
28 60 205	6	2035.75	108	59	49	43	2.5	63.6	127.23	16	16	18	26	17	31.4	1973.00	15.7	40.40	
28 61 205	6	2035.75	108	59	49	43	2.5	63.6	127.23	without Mounting Holes									40.40
28 80 055 ¹⁾	8	502.65	20	79	79	71	2.5	62.8	125.66	4	25	22	33	21	26.6	449.45	19.7	22.38	
28 81 055	8	502.65	20	79	79	71	2.5	62.8	125.66	without Mounting Holes									22.38
28 80 105	8	1005.30	40	79	79	71	2.5	62.8	125.66	8	25	22	33	21	26.6	952.00	19.7	44.76	
28 81 105	8	1005.30	40	79	79	71	2.5	62.8	125.66	without Mounting Holes									44.76
28 80 205	8	2010.61	80	79	79	71	2.5	62.8	125.66	16	25	22	33	21	26.6	1957.30	19.7	89.50	
28 81 205	8	2010.61	80	79	79	71	2.5	62.8	125.66	without Mounting Holes									89.50
28 10 105	10	1005.30	32	99	99	89	2.5	62.83	125.66	8	32	33	48	32	125.66	753.96	19.7	68.72	
28 11 105	10	1005.30	32	99	99	89	2.5	62.83	125.66	without Mounting Holes									68.72
28 12 105	12	1017.90	27	120	120	108	2.5	63.60	127.23	8	40	39	58	38	127.23	763.40	19.7	111.00	
28 13 105	12	1017.90	27	120	120	108	2.5	63.60	127.23	without Mounting Holes									20.00

1) The screw joint limits the feed force.

Total pitch error: $GT_f/500 \leq 0.026$ mm, $GT_f/1000 \leq 0.034$ mm
 $GT_f/1500 \leq 0.041$ mm ($\leq 0.027/1000$ mm)
 $GT_f/2000 \leq 0.044$ mm ($\leq 0.022/1000$ mm)

- Teeth induction-hardened and ground
- Material C45
- Ground on all sides after hardening

Mounting racks, see page ZF-2.

Further information see page ZB-4.





ATLANTA-Quality 7

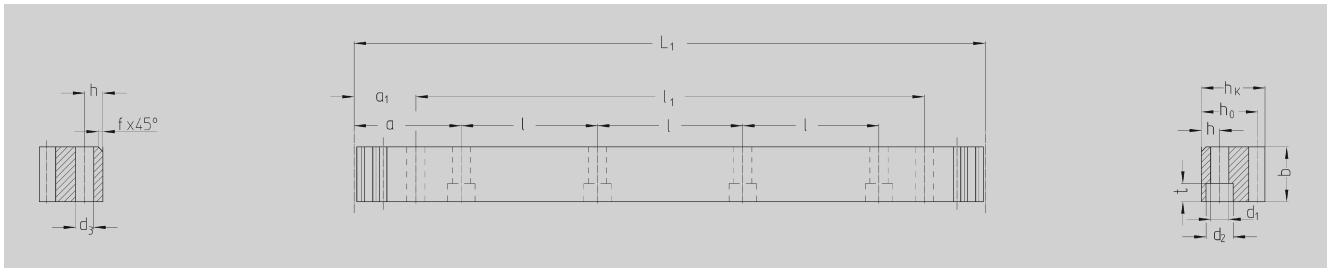

Order Code	Module	L_1	N° of Teeth	b	h_k	h_0	f	a	l	N° of Holes	h	d_1	d_2	t	a_1	l_1	d_3	kg
28 20 107	2	1005.3	160	24	24	22	2	62.8	125.66	8	8	7	11	7	31.3	942.7	5.7	4.2
28 30 107	3	1017.9	108	29	29	26	2	63.6	127.23	8	9	10	15	9	34.4	949.1	7.7	6.0
28 40 107	4	1005.3	80	39	39	35	2	62.8	125.66	8	12	14	20	13	37.5	930.3	7.7	10.5
28 50 107	5	1005.3	64	49	39	34	2.5	62.8	125.66	8	12	14	20	13	30.1	945.0	11.7	13.4
28 60 107	6	1017.88	54	59	49	43	2.5	63.6	127.23	8	16	18	26	17	31.4	955.00	15.7	20.20
28 80 107	8	1005.30	40	79	79	71	2.5	62.8	125.66	8	25	22	33	21	26.6	952.00	19.7	44.76

Total pitch error: $GT_f/1000 \leq 0.052 \text{ mm}$

- Teeth induction-hardened and ground
- Material C45
- Ground on all sides after hardening

Mounting racks see page ZF-2.

To achieve precision rack joints, we recommend our patented rack assembly kit, see page ZF-4.

For lubrication of rack & pinions we recommend our automatic lubrication systems, see page ZE-1.

For the calculation and selection of the rack & pinion drive, see page ZD-1.

Screws for rack mounting, see page ZF-3.





ATLANTA-Quality 8

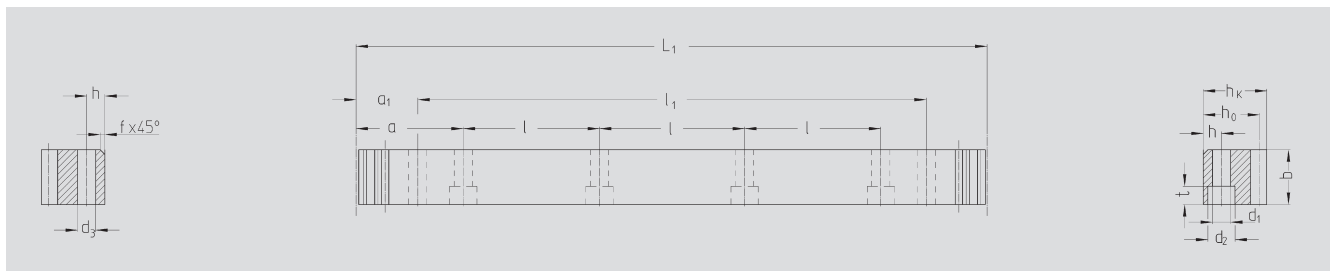

Order Code	Module	L ₁	N° of teeth	b ^{+0,4}	h _k	h ₀	f	a	l	N° of holes	h	d ₁	d ₂	t	a ₁	l ₁	d ₃	kg
34 20 108	2	1005.30	160	25	24	22	2	62.80	125.66	8	8	7	11	7	31.4	942.7	5.7	4.2
34 20 208	2	2010.62	320	25	24	22	2	62.83	125.66	16	8	7	44	7	31.3	1948.0	5.7	8.4
34 30 108	3	1017.90	108	30	29	26	2	63.60	127.23	8	9	10	15	9	34.4	949.1	7.7	6.0
34 30 208	3	2035.75	216	30	29	26	2	63.62	127.23	16	9	10	15	9	34.4	1967.0	7.7	12.0
34 40 108	4	1005.30	80	40	39	35	2	62.80	125.66	8	12	14	20	13	37.5	930.3	11.7	10.5
34 40 208	4	2010.62	160	40	39	35	2	62.83	125.66	16	12	14	20	13	37.5	1935.6	11.7	20.4
34 50 108	5	1005.30	64	50	39	34	2.5	62.80	125.66	8	12	14	20	13	30.2	945.0	11.7	13.4
34 50 208	5	2010.62	128	50	39	34	2.5	62.83	125.66	16	12	14	20	13	30.2	1950.4	11.7	27.6

Without bores on request.

Total pitch error:

$$GT_f/1000 \leq 0.060 \text{ mm}$$

$$GT_f/2000 \leq 0.078 \text{ mm } (\leq 0.039 \text{ mm}/1000)$$

- Teeth hardened with the ATLANTA high performance hardening process and ground
- Heat-treatable steel according to ATLANTA-Standard
- Bright steel, profile blasted

Mounting racks see page ZF-2.

To achieve precision rack joints, we recommend our patented rack assembly kit, see page ZF-4.

For lubrication of rack & pinions we recommend our automatic lubrication systems, see page ZE-1.

For the calculation and selection of the rack & pinion drive, see page ZD-1.

Screws for rack mounting, see page ZF-3.





ATLANTA-Quality 8

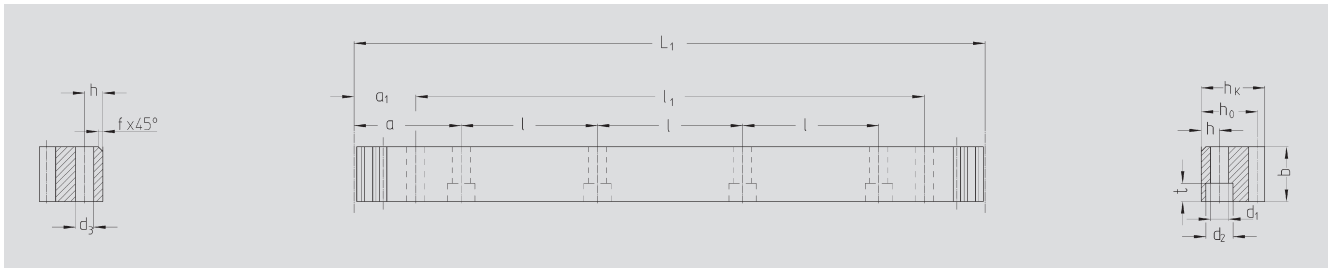

Order Code	Module	L ₁	N° of teeth	b _{-0,5}	h _k	h ₀	f	a	l	N° of holes	h	d ₁	d ₂	t	a ₁	l ₁	d ₃	kg
33 21 100	2	1005.31	160	25	24	22	2	62.83	125.66	8	8	7	11	7	31.3	942.7	5.7	4.30
33 20 100	2	1005.31	160	25	24	22	2	without mounting holes										4.30
33 21 200	2	2010.62	320	25	24	22	2	62.83	125.66	16	8	7	11	7	31.3	1948.0	5.7	8.60
33 20 200	2	2010.62	320	25	24	22	2	without mounting holes										8.60
33 31 100	3	1017.88	108	30	29	26	2	63.62	127.23	8	9	10	15	9	34.4	949.1	7.7	6.20
33 30 100	3	1017.88	108	30	29	26	2	without mounting holes										6.20
33 31 200	3	2035.75	216	30	29	26	2	63.62	127.23	16	9	10	15	9	34.4	1967.0	7.7	12.40
33 30 200	3	2035.75	216	30	29	26	2	without mounting holes										12.40
33 41 100	4	1005.31	80	40	39	35	2	62.83	125.66	8	12	10	15	9	37.5	930.3	7.7	11.00
33 40 100	4	1005.31	80	40	39	35	2	without mounting holes										11.00
33 41 200	4	2010.62	160	40	39	35	2	62.83	125.66	16	12	10	15	9	37.5	1935.6	7.7	22.00
33 40 200	4	2010.62	160	40	39	35	2	without mounting holes										22.00

500 mm and other length on request.

Total pitch error

$$GT_f / 1000 \leq 0.100 \text{ mm,}$$

$$GT_f / 2000 \leq 0.200 \text{ mm.}$$

- Milled teeth, quenched and tempered
- Heat-treatable steel according to ATLANTA-Standard
- Bright steel, backside machined

Mounting racks see page ZF-2.

To achieve precision rack joints, we recommend our patented rack assembly kit, see page ZF-4.

For lubrication of rack & pinions we recommend our automatic lubrication systems, see page ZE-1.

For the calculation and selection of the rack & pinion drive, see page ZD-1.

Screws for rack mounting, see page ZF-3.





ATLANTA-Quality 9

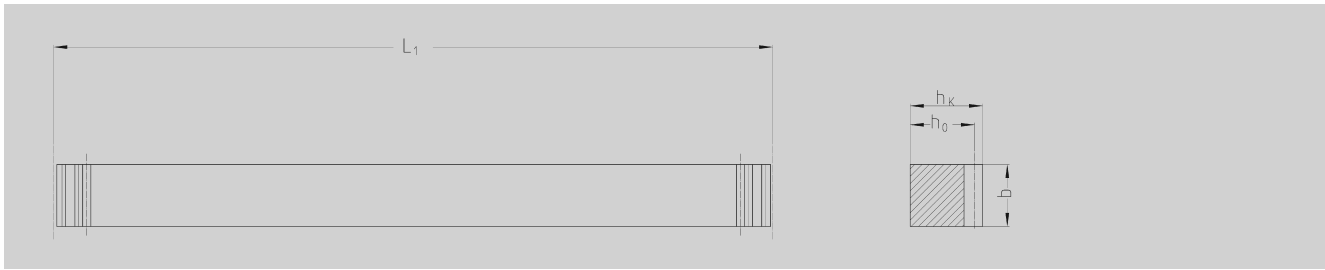

Order Code	Module	L ₁	N° of Teeth	b	h _k	h ₀	Remarks	kg
25 10 025	1	251.33	80	15	15	14	Square Dimension	0.41
25 10 050	1	499.51	159	15	15	14	Square Dimension	0.82
25 10 100	1	999.03	318	15	15	14	Square Dimension	1.64
25 15 025	1.5	249.76	53	17	17	15.5	Square Dimension	0.51
25 15 050	1.5	499.51	106	17	17	15.5	Square Dimension	1.03
25 15 100	1.5	999.03	212	17	17	15.5	Square Dimension	2.06
25 15 200	1.5	1998.05	424	17	17	15.5	Square Dimension	4.11
25 20 025	2	251.33	40	20	20	18	Square Dimension	0.71
25 20 050	2	502.65	80	20	20	18	Square Dimension	1.41
25 20 100	2	999.03	159	20	20	18	Square Dimension	2.81
25 20 150	2	1507.96	240	20	20	18	Square Dimension	4.25
25 20 200	2	1998.05	318	20	20	18	Square Dimension	5.62
25 20 300	2	3015.93	480	20	20	18	Square Dimension	8.49
25 25 025	2.5	251.33	32	25	25	22.5	Square Dimension	1.10
25 25 050	2.5	502.65	64	25	25	22.5	Square Dimension	2.21
25 25 100	2.5	997.46	127	25	25	22.5	Square Dimension	4.38
25 25 200	2.5	2002.77	255	25	25	22.5	Square Dimension	8.80
25 30 025	3	254.47	27	30	30	27	Square Dimension	1.61
25 30 051	3	508.94	54	30	30	27	Square Dimension	3.22
25 30 101	3	1017.88	108	30	30	27	Square Dimension	6.44
25 30 150	3	1526.81	162	30	30	27	Square Dimension	9.66
25 30 201	3	2035.75	216	30	30	27	Square Dimension	12.88
25 30 300	3	3053.63	324	30	30	27	Square Dimension	19.32
25 40 025	4	251.33	20	40	40	36	Square Dimension	2.83
25 40 050	4	502.65	40	40	40	36	Square Dimension	5.65
25 40 100	4	1005.31	80	40	40	36	Square Dimension	11.31
25 40 150	4	1507.96	120	40	40	36	Square Dimension	19.97
25 40 201	4	2010.62	160	40	40	36	Square Dimension	22.61
25 40 300	4	3015.93	240	40	40	36	Square Dimension	33.93

Total pitch error $GT_f/1000 \leq 0.150$ mm.

- Milled teeth
- Material C45
- Bright steel

Mounting racks see page ZF-2.

To achieve precision rack joints, we recommend our patented rack assembly kit, see page ZF-4.

For lubrication of rack & pinions we recommend our automatic lubrication systems, see page ZE-1.

For the calculation and selection of the rack & pinion drive, see page ZD-1.

Screws for rack mounting, see page ZF-3.





ATLANTA-Quality 9

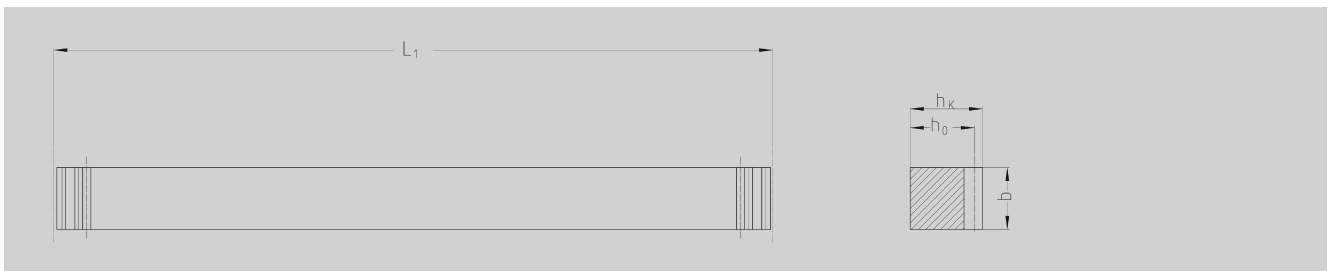

Order Code	Module	L ₁	N° of Teeth	b	h _k	h ₀	Remarks	kg
25 50 025	5	251.33	16	50	40	35	Not square dimension	3.44
25 50 050	5	502.65	32	50	40	35	Not square dimension	6.87
25 50 100	5	1005.31	64	50	40	35	Not square dimension	13.74
25 50 150	5	1507.96	96	50	40	35	Not square dimension	20.40
25 50 200	5	2010.62	128	50	40	35	Not square dimension	27.48
25 52 100	5	1005.31	64	50	50	45	Square dimension	17.10
25 52 200	5	2010.62	128	50	50	45	Square dimension	34.20
25 60 051	6	508.94	27	60	50	44	Not square dimension	10.49
25 60 101	6	1017.88	54	60	50	44	Not square dimension	20.99
25 60 201	6	2035.75	108	60	50	44	Not square dimension	41.97
25 62 101	6	1017.88	54	60	60	54	Square dimension	25.00
25 62 201	6	2035.75	108	60	60	54	Square dimension	50.00
25 80 100	8	1005.31	40	80	79.5	71.5	Square dimension	44.63
25 80 200	8	2010.62	80	80	79.5	71.5	Square dimension	89.26
25 11 100	10	1005.30	32	100	100	90	Square dimension	70.60

Total pitch error $GT_f/1000 \leq 0.150$ mm.

- Milled teeth
- Material C45
- Bright steel

Mounting racks see page ZF-2.



To achieve precision rack joints, we recommend our patented rack assembly kit, see page ZF-4.

For lubrication of rack & pinions we recommend our automatic lubrication systems, see page ZE-1.

For the calculation and selection of the rack & pinion drive, see page ZD-1.

Screws for rack mounting, see page ZF-3.



ATLANTA-Quality 10

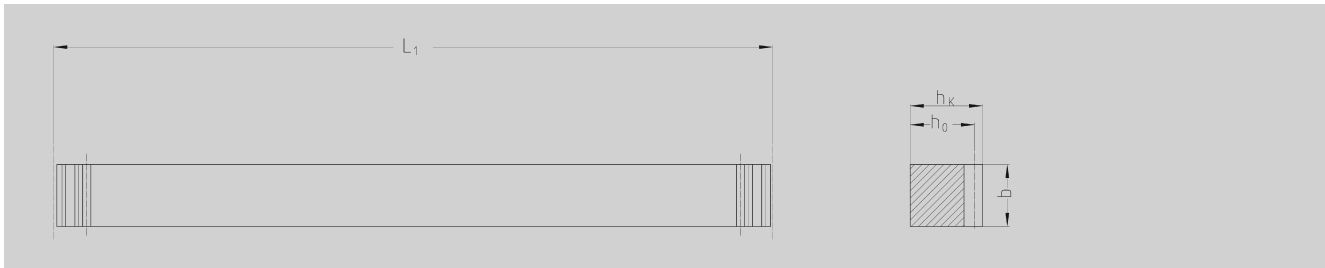

Order Code	Module	L ₁	N° of Teeth	b	h _k	h ₀	Remarks	kg
27 10 025	1	251.33	80	15	15	14	Square dimension	0.41
27 10 050	1	499.51	159	15	15	14	Square dimension	0.82
27 10 100	1	999.03	318	15	15	14	Square dimension	1.64
27 15 025	1.5	249.76	53	17	17	15.5	Square dimension	0.51
27 15 050	1.5	499.51	106	17	17	15.5	Square dimension	1.03
27 15 100	1.5	999.03	212	17	17	15.5	Square dimension	2.06
27 15 200	1.5	1998.05	424	17	17	15.5	Square dimension	4.11
27 20 025	2	251.33	40	20	20	18	Square dimension	0.71
27 20 050	2	502.65	80	20	20	18	Square dimension	1.41
27 20 100	2	999.03	159	20	20	18	Square dimension	2.81
27 20 150	2	1507.96	240	20	20	18	Square dimension	4.25
27 20 200	2	1998.05	318	20	20	18	Square dimension	5.62
27 20 300	2	3015.93	480	20	20	18	Square dimension	8.49
27 25 025	2.5	251.33	32	25	25	22.5	Square dimension	1.10
27 25 050	2.5	502.65	64	25	25	22.5	Square dimension	2.21
27 25 100	2.5	997.46	127	25	25	22.5	Square dimension	4.38
27 25 200	2.5	2002.77	255	25	25	22.5	Square dimension	8.80
27 30 025	3	254.47	27	30	30	27	Square dimension	1.61
27 30 051	3	508.94	54	30	30	27	Square dimension	3.22
27 30 101	3	1017.88	108	30	30	27	Square dimension	6.44
27 30 150	3	1526.81	162	30	30	27	Square dimension	9.66
27 30 201	3	2035.75	216	30	30	27	Square dimension	12.88
27 30 300	3	3053.63	324	30	30	27	Square dimension	19.32
27 40 025	4	251.33	20	40	40	36	Square dimension	2.83
27 40 050	4	502.65	40	40	40	36	Square dimension	5.65
27 40 100	4	1005.31	80	40	40	36	Square dimension	11.31
27 40 150	4	1507.96	120	40	40	36	Square dimension	19.97
27 40 201	4	2010.62	160	40	40	36	Square dimension	22.61
27 40 300	4	3015.93	240	40	40	36	Square dimension	33.93

Total pitch error $GT_f/1000 \leq 0.200$ mm.

- Milled teeth and induction hardened
- Material C45
- Bright steel

Mounting racks see page ZF-2.

To achieve precision rack joints, we recommend our patented rack assembly kit, see page ZF-4.

For lubrication of rack & pinions we recommend our automatic lubrication systems, see page ZE-1.

For the calculation and selection of the rack & pinion drive, see page ZD-1.

Screws for rack mounting see page ZF-3.

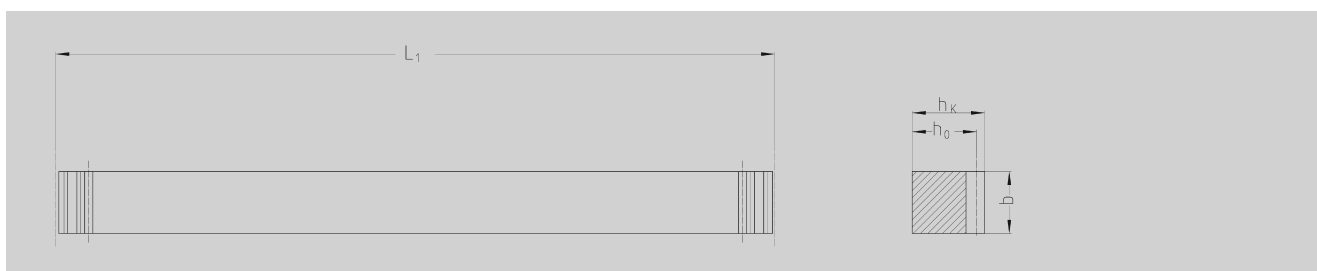

**ATLANTA-Quailty 10**

Order Code	Module	L ₁	N° of Teeth	b	h _k	h ₀	Remarks	kg
27 50 025	5	251.33	16	50	40	35	Not square dimension	3.44
27 50 050	5	502.65	32	50	40	35	Not square dimension	6.87
27 50 100	5	1005.31	64	50	40	35	Not square dimension	13.74
27 50 150	5	1507.96	96	50	40	35	Not square dimension	20.40
27 50 200	5	2010.62	128	50	40	35	Not square dimension	27.48
27 52 100	5	1005.31	64	50	50	45	Square dimension	17.10
27 52 200	5	2010.62	128	50	50	45	Square dimension	34.20
27 60 051	6	508.94	27	60	50	44	Not square dimension	10.49
27 60 101	6	1017.88	54	60	50	44	Not square dimension	20.99
27 60 201	6	2035.75	108	60	50	44	Not square dimension	41.97
27 62 101	6	1017.88	54	60	60	54	Square dimension	25.00
27 62 201	6	2035.75	108	60	60	54	Square dimension	50.00
27 80 100	8	1005.31	40	80	79.5	71.5	Square dimension	44.63
27 80 200	8	2010.62	80	80	79.5	71.5	Square dimension	89.26
27 11 100	10	1005.30	32	100	100	90	Square dimension	70.60

Total pitch error $GT_f/1000 \leq 0.200$ mm.

- Milled teeth and induction hardened
- Material C45
- Bright steel

Mounting racks see page ZF-2.



To achieve precision rack joints, we recommend our patented rack assembly kit, see page ZF-4.

For lubrication of rack & pinions we recommend our automatic lubrication systems, see page ZE-1.

For the calculation and selection of the rack & pinion drive, see page ZD-1.

Screws for rack mounting, see page ZF-3.



ATLANTA-Quality 10

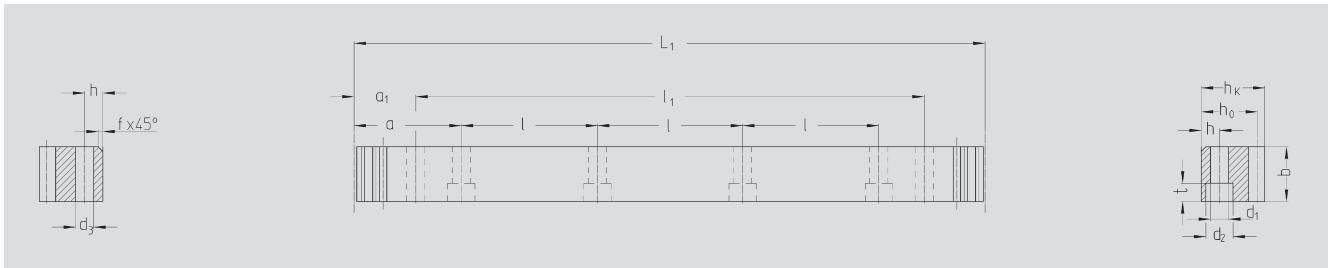

Order Code	Module	L ₁	N° of teeth	b	h _k	h ₀	f	a	l	N° of holes	h	d ₁	d ₂	t	a ₁	l ₁	d ₃	kg
34 93 100	1	999.06	318	15	15	14	2			without mounting holes								1.64
34 93 200	1	1998.05	636	15	15	14	2			without mounting holes								3.28
34 16 100	1.5	999.03	212	17	17	15.5	2			without mounting holes								2.06
34 16 200	1.5	1998.05	424	17	17	15.5	2			without mounting holes								4.12
34 20 100	2	1005.31	160	25	24	22	2	62.83	125.66	8	8	7	11	7	31.3	942.7	5.7	4.20
34 21 100	2	1005.31	160	25	24	22	2			without mounting holes								4.20
34 20 200	2	2010.62	320	25	24	22	2	62.83	125.66	16	8	7	11	7	31.3	1948.0	5.7	8.40
34 21 200	2	2010.62	320	25	24	22	2			without mounting holes								8.40
34 30 100	3	1017.88	108	30	29	26	2	63.62	127.23	8	9	10	15	9	34.4	949.1	7.7	6.00
34 31 100	3	1017.88	108	30	29	26	2			without mounting holes								6.00
34 30 200	3	2035.75	216	30	29	26	2	63.62	127.23	16	9	10	15	9	34.4	1967	7.7	12.00
34 31 200	3	2035.75	216	30	29	26	2			without mounting holes								12.00
34 40 100 ¹⁾	4	1005.31	80	40	39	35	2	62.83	125.66	8	12	10	15	9	37.5	930.3	7.7	10.20
34 41 100	4	1005.31	80	40	39	35	2			without mounting holes								10.20
34 42 100	4	1005.31	80	40	39	35	2	62.83	125.66	8	12	14	20	13	37.5	930.3	11.7	10.20
34 40 200 ¹⁾	4	2010.62	160	40	39	35	2	62.83	125.66	16	12	10	15	9	37.5	1935.6	7.7	20.50
34 41 200	4	2010.62	160	40	39	35	2			without mounting holes								20.50
34 42 200	4	2010.62	160	40	39	35	2	62.83	125.66	16	12	14	20	13	37.5	1935.6	11.7	20.50
34 50 100	5	1005.31	64	50	39	34	2.5	62.83	125.66	8	12	14	20	13	30.2	945.0	11.7	13.80
34 51 100	5	1005.31	64	50	39	34	2.5			without mounting holes								13.80
34 50 200	5	2010.62	128	50	39	t34	2.5	62.83	125.66	16	12	14	20	13	30.2	1950.3	11.7	27.50
34 51 200	5	2010.62	128	50	39	34	2.5			without mounting holes								27.50
34 60 100	6	1017.88	54	60	49	43	2.5	63.62	127.23	8	16	18	26	17	31.4	955.0	15.7	21.00
34 61 100	6	1017.88	54	60	49	43	2.5			without mounting holes								21.00
34 60 200	6	2035.75	108	60	49	43	2.5	63.62	127.23	16	16	18	26	17	31.4	1972.9	15.7	42.00
34 61 200	6	2035.75	108	60	49	43	2.5			without mounting holes								42.00
34 81 100	8	1005.31	40	80	79	71	2.5			without mounting holes								44.63
34 81 200	8	2010.61	80	80	79	71	2.5			without mounting holes								82.26
34 11 100	10	1005.30	32	100	99	89	2.5			without mounting holes								70.60

1) The screw joint limits the feed force.

500 mm and other length on request.

Total pitch error

$$GT_f/1000 \leq 0.200 \text{ mm,}$$

$$GT_f/1500 \leq 0.300 \text{ mm,}$$

$$GT_f/2000 \leq 0.400 \text{ mm.}$$

- Teeth hardened with the ATLANTA high performance hardening process
- Heat-treatable steel according to ATLANTA-Standard
- Bright steel

Mounting racks see page ZF-2.

To achieve precision rack joints, we recommend our patented rack assembly kit, see page ZF-4.

For lubrication of rack & pinions we recommend our automatic lubrication systems, see page ZE-1.

For the calculation and selection of the rack & pinion drive, see page ZD-1.

Screws for rack mounting, see page ZF-3.





Bolt Circle-ø 50, straight tooth system

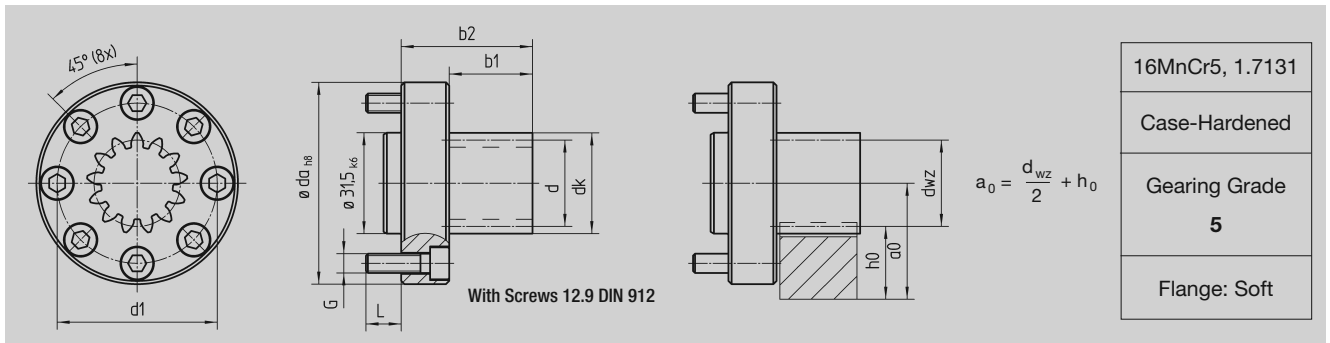

Order Code	No. of Teeth	Profile Modification Factor								Interface				
			z	x	d _{wz}	d _k	b ₁	b ₂	L	a ₀	ISO	d ₁	G	d _{ah8}
Module 2														
78 21 813	13	0.366	27.47	31.5	26	41	81.68	35.73	9409-1-A-50	50	M6	63	11	0.5
78 21 817	17	-0.012	33.95	38.0	26	41	106.81	38.98	9409-1-A-50	50	M6	63	11	0.6

Further number of teeth on request, min. number of teeth 13, max. number of teeth 17

Bolt Circle-ø 63, straight tooth system

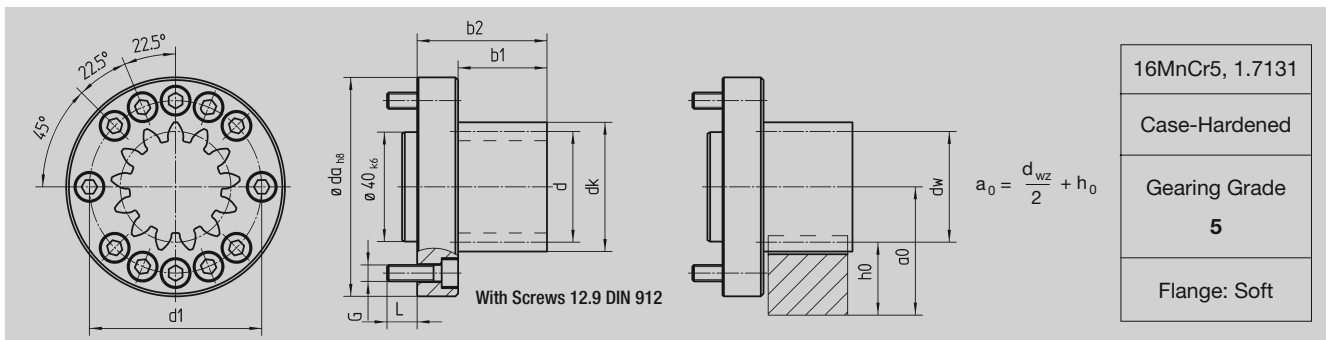

Order Code	No. of Teeth	Profile Modification Factor								Interface				
			z	x	d _{wz}	d _k	b ₁	b ₂	L	a ₀	ISO	d ₁	G	d _{ah8}
Module 2														
78 22 813	13	0.366	27.47	31.5	26	41	81.68	35.73	9409-1-A-63	63	M6	80	11	0.8
78 22 817	17	-0.012	33.95	38.0	26	41	106.81	38.98	9409-1-A-63	63	M6	80	11	0.8
78 22 824	24	0.202	48.81	52.8	26	41	150.80	46.40	9409-1-A-63	63	M6	80	11	1.0

Further number of teeth on request, min. number of teeth 13, max. number of teeth 24

Highlighted items will become obsolete in the future. Please check with the factory for delivery information.

Module 3														
Order Code	No. of Teeth	Profile Modification Factor	d _{wz}	d _k	b ₁	b ₂	L	a ₀	ISO	d ₁	G	d _{ah8}	L	kg
78 32 813	13	0.366	41.20	47.2	32.5	47.5	122.52	46.60	9409-1-A-63	63	M6	80	11	1.0

Further number of teeth on request, min. number of teeth 13, max. number of teeth 15



Bolt Circle- $\varnothing 80$, straight tooth system

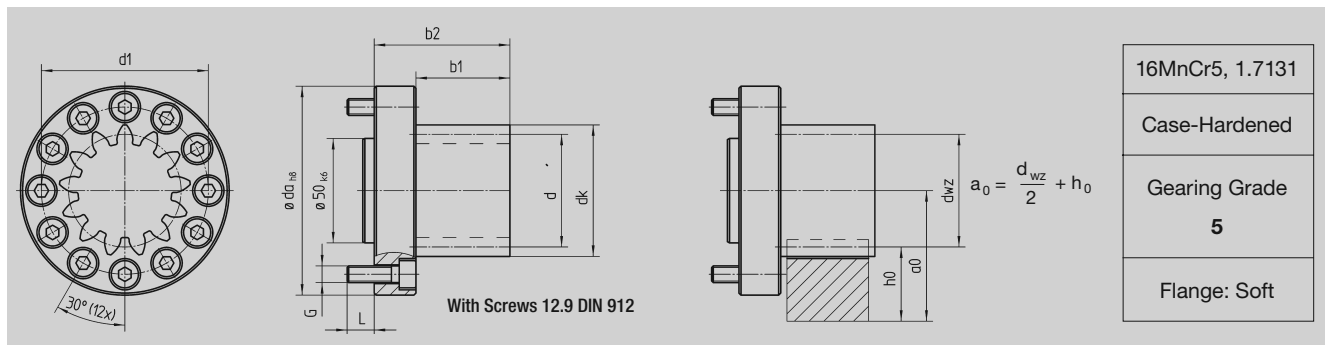

Order Code	No. of Teeth	Profile Modification Factor	Interface											kg
			d_{wz}	d_k	b_1	b_2	L	a_0	ISO	d_1	G	d_{ah8}	L	
Module 2														
78 23 813	13	0.366	27.47	31.5	26	46	81.68	35.73	9409-1-A-80	80	M8	100	13	1.4
78 23 824 ⁽¹⁾	24	0.202	48.81	52.8	26	46	150.80	46.40	9409-1-A-80	80	M8	100	13	1.6
Further number of teeth on request, min. number of teeth 13, max. number of teeth 31														
Module 3														
78 33 813	13	0.366	41.20	47.2	32.5	52.5	122.52	46.60	9409-1-A-80	80	M8	100	13	1.6
78 33 820	20	0.080	60.48	66.5	32.5	52.5	188.50	56.24	9409-1-A-80	80	M8	100	13	2.0
Further number of teeth on request, min. number of teeth 13, max. number of teeth 20														
Module 4														
78 43 813	13	0.366	54.93	62.9	45	65	163.36	62.47	9409-1-A-80	80	M8	100	13	2.1
78 43 814	14	0.397	59.17	67.2	45	65	175.93	64.59	9409-1-A-80	80	M8	100	13	2.2

⁽¹⁾ Also available as pinion for counter bearing.

Highlighted items will become obsolete in the future. Please check with the factory for delivery information.





Bolt Circle- $\varnothing 125$, straight tooth system

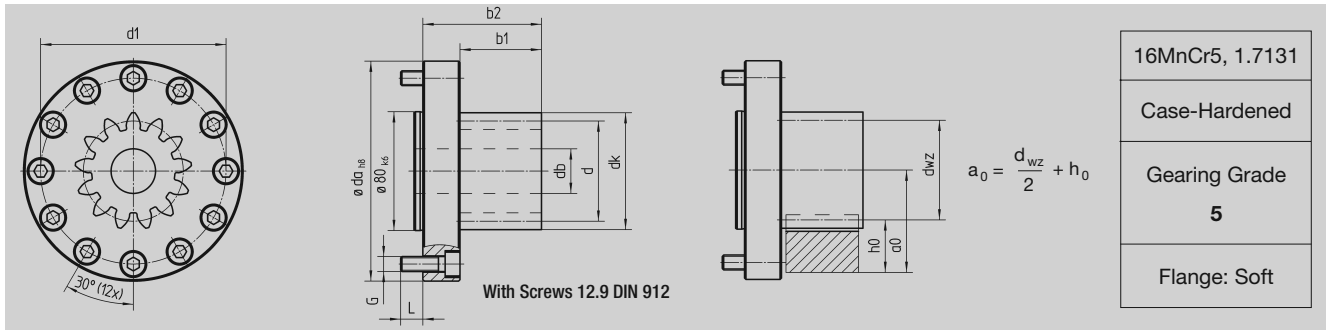

Order Code	No. of Teeth	Profile Modification Factor	Interface							ISO	d ₁	G	d _{ah8}	L	d _b	kg
			z	x	d _{wz}	d _k	b ₁	b ₂	L							
Module 3																
78 34 813	13	0.366	41.20	47.2	32.5	57.5	122.52	46.60	9409-1-A-125	125	M10	148	15	-	3.8	
78 34 413	13	0.366	41.20	47.2	32.5	57.5	122.52	46.60	-	125	M12	148	17	-	3.8	
78 34 820	20	0.080	60.48	66.5	32.5	57.5	188.50	56.24	9409-1-A-125	125	M10	148	15	-	4.2	
78 34 420	20	0.080	60.48	66.5	32.5	57.5	188.50	56.24	-	125	M12	148	17	-	4.2	
78 34 427	27	0.294	82.76	88.8	32.5	57.5	254.47	67.38	-	125	M12	148	17	-	4.9	
78 34 433	33	0.477	101.86	107.9	32.5	57.5	311.02	76.93	-	125	M12	148	17	-	5.6	

Further number of teeth on request, min. number of teeth 13, max. number of teeth 34

Highlighted items will become obsolete in the future. Please check with the factory for delivery information.

Module 4

78 44 813	13	0.366	54.93	62.9	45	70	163.36	62.47	9409-1-A-125	125	M10	148	15	-	4.4
78 44 413	13	0.366	54.93	62.9	45	70	163.36	62.47	-	125	M12	148	17	-	4.4
78 44 820	20	0.190	81.52	89.5	45	70	256.10	75.76	9409-1-A-125	125	M10	148	15	-	5.4
78 44 420	20	0.190	81.52	89.5	45	70	256.10	75.76	-	125	M12	148	17	-	5.4
78 44 821 ⁽¹⁾	21	0.110	84.88	92.9	45	70	263.89	77.44	9409-1-A-125	125	M10	148	15	-	5.5
78 44 421	21	0.110	84.88	92.9	45	70	263.89	77.44	-	125	M12	148	17	-	5.5
78 44 824	24	0.202	97.61	105.6	45	70	301.59	83.81	9409-1-A-125	125	M10	148	15	-	6.1
78 44 424	24	0.202	97.61	105.6	45	70	301.59	83.81	-	125	M12	148	17	-	6.1

Further number of teeth on request, min. number of teeth 13, max. number of teeth 24

Highlighted items will become obsolete in the future. Please check with the factory for delivery information.

Module 5

78 54 813	13	0.366	68.66	78.7	55	80	204.20	68.33(2)	9409-1-A-125	125	M10	148	15	-	5.1
78 54 413	13	0.366	68.66	78.7	55	80	204.20	68.33(2)	-	125	M12	148	17	-	5.1
78 54 417	17	-0.012	84.88	94.9	55	80	267.04	79.44(2)	-	125	M12	148	17	-	6.0
78 54 819	19	0.049	95.49	105.5	55	80	298.45	81.75(2)	9409-1-A-125	125	M10	148	15	-	6.6
78 54 419	19	0.049	95.49	105.5	55	80	298.45	81.75(2)	-	125	M12	148	17	-	6.6

Further number of teeth on request, min. number of teeth 13, max. number of teeth 19

Highlighted items will become obsolete in the future. Please check with the factory for delivery information.

Module 6

78 64 813	13	0.366	82.40	94.4	65	90	245.04	84.20	9409-1-A-125	125	M10	148	15	25	5.8
78 64 413	13	0.366	82.40	94.4	65	90	245.04	84.20	-	125	M12	148	17	25	5.9
78 64 814	14	0.397	88.76	100.8	65	90	263.89	87.38	9409-1-A-125	125	M10	148	15	25	6.3
78 64 816	16	-0.042	95.49	107.5	65	90	301.59	90.75	9409-1-A-125	125	M10	148	15	25	6.8

Further number of teeth on request, min. number of teeth 13, max. number of teeth 16

⁽¹⁾ Also available as pinion for counter bearing.

⁽²⁾ For 29 55 ... a'₀ = a₀ + 10.

Highlighted items will become obsolete in the future. Please check with the factory for delivery information.



Bolt Circle- ϕ 140, straight tooth system

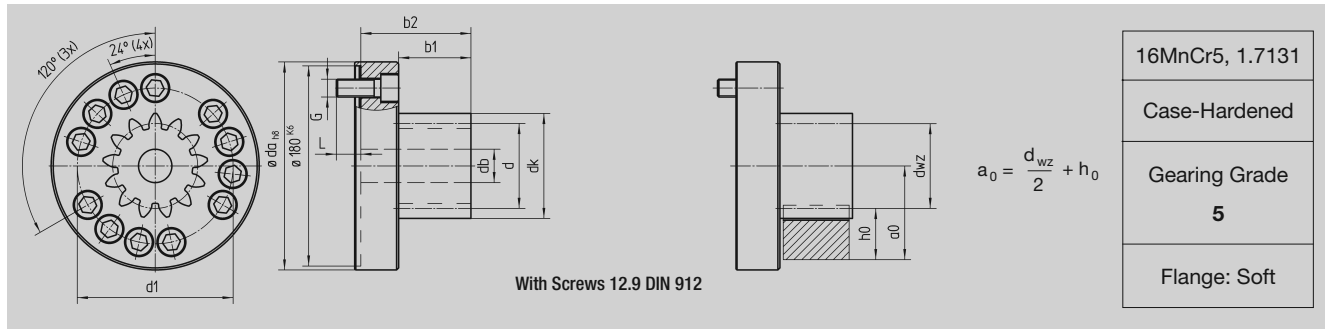

Order Code	No. of Teeth	Profile Modification Factor	Interface							ISO	d_1	G	d_{ah8}	L	d_b	kg
			d_{wz}	d_k	b_1	b_2	L	a_0								
Module 4																
78 46 813	13	0.366	54.93	62.9	45	79	163.36	62.47	-	140	M16	187	22	-	8.1	
78 46 820	20	0.190	81.52	89.5	45	79	256.10	75.76	-	140	M16	187	22	-	9.1	
78 46 821	21	0.110	84.88	92.9	45	79	263.89	77.44	-	140	M16	187	22	-	9.2	

Further number of teeth on request, min. number of teeth 13, max. number of teeth 26

Highlighted items will become obsolete in the future. Please check with the factory for delivery information.

Module 5																
78 56 815	15	0.227	77.27	87.3	55	89	235.62	72.64(2)	-	140	M16	187	22	-	9.2	
78 56 820	20	0.080	100.80	110.8	55	89	314.16	84.40(2)	-	140	M16	187	22	-	10.6	

Further number of teeth on request, min. number of teeth 13, max. number of teeth 21

Highlighted items will become obsolete in the future. Please check with the factory for delivery information.

Module 6																
78 66 813	13	0.366	82.40	94.4	65	99	245.04	84.20	-	140	M16	187	22	25	9.5	
78 66 817 ⁽¹⁾	17	-0.012	101.86	113.9	65	99	320.44	93.93	-	140	M16	187	22	25	10.9	

Further number of teeth on request, min. number of teeth 13, max. number of teeth 17

Highlighted items will become obsolete in the future. Please check with the factory for delivery information.

⁽¹⁾ Also available as pinion for counter bearing.

⁽²⁾ For 29 55 ... $a_0 = a_0 + 10$.





Bolt Circle-ø 160, straight tooth system

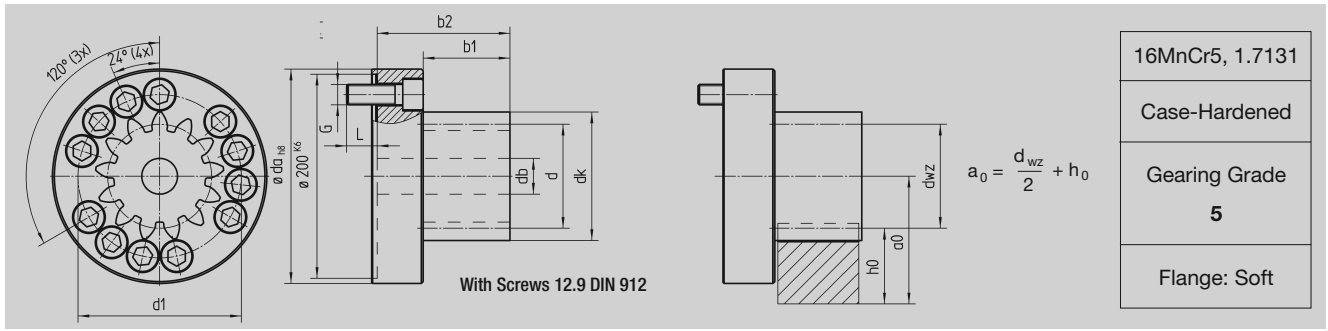

Order Code	No. of Teeth	Profile Modification Factor	Interface							ISO	d ₁	G	d _{ah8}	L	d _b	kg
			d _{wz}	d _k	b ₁	b ₂	L	a ₀								
Module 5																
78 57 813	13	0.366	68.66	78.7	55	100	204.20	68.33(2)	-	160	M20	210	30	-	13.8	
78 57 820	20	0.080	100.80	110.8	55	100	314.16	84.40(2)	-	160	M20	210	30	-	15.6	

Further number of teeth on request, min. number of teeth 13, max. number of teeth 23

Highlighted items will become obsolete in the future. Please check with the factory for delivery information.

Module 6																
78 67 813	13	0.366	82.39	94.4	65	110	245.04	84.20	-	160	M20	210	30	25	14.5	
78 67 817	17	-0.012	101.86	113.9	65	110	320.44	93.93	-	160	M20	210	30	25	15.9	
78 67 819	19	0.049	114.59	126.6	65	110	358.14	100.30	-	160	M20	210	30	25	17.0	

Further number of teeth on request, min. number of teeth 13, max. number of teeth 19

Highlighted items will become obsolete in the future. Please check with the factory for delivery information.

Module 8																
78 87 813	13	0.366	109.86	125.9	85	130	326.73	125.93	-	160	M20	210	30	30	17.8	

(2) For 29 55 ... a'₀ = a₀ + 10.





Straight Tooth System, with Bore ØH6 and Keyway acc. to DIN 6885

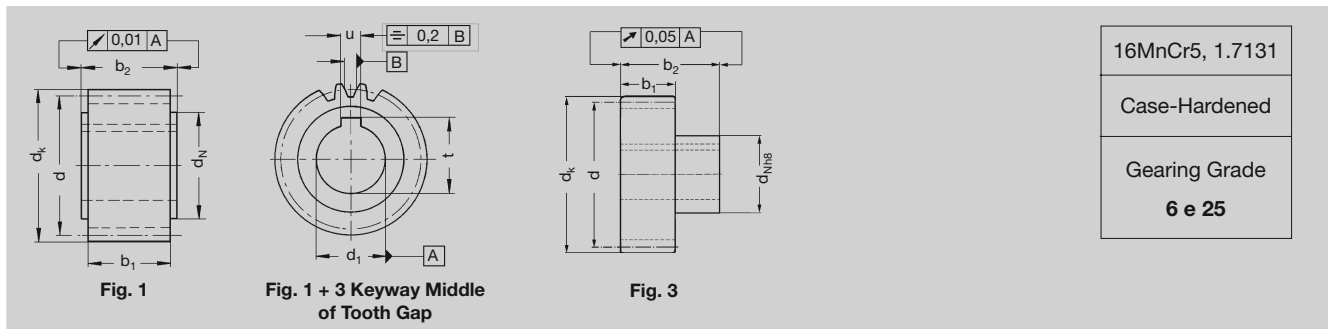

16MnCr5, 1.7131
Case-Hardened
Gearing Grade
6 e 25

Order Code	Fig.	N° of Teeth z	d	d _k	d ₁ ^{H6}	d _N	b ₁	b ₂	u	t	kg	Shrink-Disk on Page GH-1
Module 2												
24 21 216	1	16	32	36	15	25	28	30.0	5	17.3	0.1	
24 21 218	1	18	36	40	15	28	28	30.0	5	17.3	0.2	
24 22 218	1	18	36	40	20	28	28	30.0	6	22.8	0.2	
24 21 220	1	20	40	44	15	25	28	30.0	5	17.3	0.2	
24 29 420	3	20	40	44	19*	30	28	56.0	6	21.8	0.2	80 83 030
24 29 220	1	20	40	44	19*	30	28	30.0	6	21.8	0.2	
24 22 220	1	20	40	44	20*	30	28	30.0	6	22.8	0.2	
24 20 120	3	20	40	44	22*	36	28	56.0	6	24.8	0.3	80 84 036
24 20 220	1	20	40	44	22*	30	28	30.0	6	24.8	0.2	
24 21 222	1	22	44	48	15	25	28	30.0	5	17.3	0.3	
24 29 222	1	22	44	48	19*	30	28	30.0	6	21.8	0.3	
24 29 422	3	22	44	48	19*	30	28	56.0	6	21.8	0.3	80 83 030
24 22 222	1	22	44	48	20	30	28	30.0	6	22.8	0.3	
24 20 222	1	22	44	48	22*	30	28	30.0	6	24.8	0.2	
24 20 122	3	22	44	48	22	36	28	56.0	6	27.8	0.2	80 84 036
24 23 222	1	22	44	48	25	36	28	30.0	8	28.3	0.2	
24 21 225	1	25	50	54	15	25	28	30.0	5	17.3	0.4	
24 26 225	3	25	50	54	16	30	28	54.0	5	18.3	0.3	80 83 030
24 29 225	1	25	50	54	19*	30	28	30.0	6	21.8	0.3	
24 29 425	3	25	50	54	19*	30	28	56.0	6	21.8	0.3	80 83 030
24 22 225	1	25	50	54	20	30	28	30.0	6	22.8	0.4	
24 20 225	1	25	50	54	22	30	28	30.0	6	24.8	0.3	
24 20 425	3	25	50	54	22*	36	28	56.0	6	24.8	0.4	80 84 036
24 23 225	1	25	50	54	25	36	28	30.0	8	28.3	0.3	
24 24 225	1	25	50	54	30	45	28	30.0	8	33.3	0.3	
24 21 228	1	28	56	60	15	25	28	30.0	5	17.3	0.5	
24 29 228	1	28	56	60	19*	30	28	30.0	6	21.8	0.5	
24 29 428	3	28	56	60	19*	30	28	56.0	6	21.8	0.5	80 83 030
24 22 228	1	28	56	60	20	30	28	30.0	6	22.8	0.5	
24 20 128	3	28	56	60	22*	36	28	56.0	6	24.8	0.3	80 84 036
24 20 228	1	28	56	60	22*	30	28	30.0	6	24.8	0.3	
24 23 228	1	28	56	60	25	36	28	30.0	8	28.3	0.4	
24 22 428	3	28	56	60	30	50	28	60.0	8	33.3	0.4	80 85 050
24 24 228	1	28	56	60	30	45	28	30.0	8	33.3	0.4	
24 25 228	1	28	56	60	35	48	28	30.0	10	38.3	0.3	
24 21 232	1	32	64	68	15	36	28	30.0	5	17.3	0.6	
24 26 232	3	32	64	68	16	30	28	54.0	5	18.3	0.6	80 83 030
24 22 232	1	32	64	68	20	30	28	30.0	6	22.8	0.6	
24 20 232	1	32	64	68	22*	30	28	30.0	6	24.8	0.4	
24 20 432	3	32	64	68	22	36	28	56.0	6	24.8	0.6	80 84 036
24 23 232	1	32	64	68	25	36	28	30.0	8	28.3	0.6	
24 22 432	3	32	64	68	30	50	28	60.0	8	33.3	0.6	80 85 050
24 24 232	1	32	64	68	30	45	28	30.0	8	33.3	0.6	
24 23 432	3	32	64	68	32	55	28	65.0	10	35.3	0.5	80 80 055
24 25 232	1	32	64	68	35	48	28	30.0	10	38.3	0.5	
24 22 236	1	36	72	76	20	30	28	30.0	6	22.8	0.8	
24 23 236	1	36	72	76	25	36	28	30.0	8	28.3	0.8	
24 24 236	1	36	72	76	30	45	28	30.0	8	33.3	0.7	
24 25 236	1	36	72	76	35	48	28	30.0	10	38.3	0.7	
24 25 436	3	36	72	76	40	62	28	65.0	12	43.3	0.5	80 86 062
24 27 236	1	36	72	76	45	58	28	30.0	14	48.8	0.6	

* H7 tolerance





Straight Tooth System, with Bore ØH6 and Keyway acc. to DIN 6885

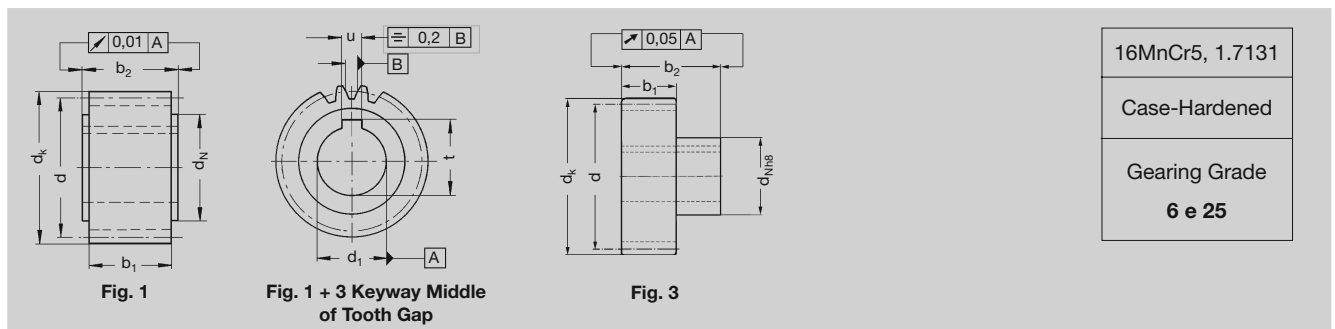

16MnCr5, 1.7131
Case-Hardened
Gearing Grade 6 e 25

Order Code	Fig.	N° of Teeth z	d	d _k	d ₁ ^{H6}	d _N	b ₁	b ₂	u	t	kg	Shrink-Disk on Page GH-1
Modul / Module 2												
24 21 240	1	40	80	84	15	36	28	30.0	5	17.3	1.0	
24 22 240	1	40	80	84	20	30	28	30.0	6	22.8	1.0	
24 23 240	1	40	80	84	25	36	28	30.0	8	28.3	1.0	
24 24 240	1	40	80	84	30	45	28	30.0	8	33.3	1.0	
24 23 440	3	40	80	84	32	55	28	65.0	10	35.3	0.9	80 80 055
24 25 240	1	40	80	84	35	48	28	30.0	10	38.3	0.9	
24 25 440	3	40	80	84	40	62	28	65.0	12	43.3	0.7	80 86 062
24 26 440	3	40	80	84	45	68	28	65.0	14	48.8	1.3	80 80 068
24 27 240	1	40	80	84	45	58	28	30.0	14	48.8	0.8	
24 22 245	1	45	90	94	20	30	28	30.0	6	22.8	1.3	
24 23 245	1	45	90	94	25	36	28	30.0	8	28.3	1.2	
24 25 245	1	45	90	94	35	48	28	30.0	10	38.3	1.2	
24 27 245	1	45	90	94	45	58	28	30.0	14	48.8	1.1	
24 22 250	1	50	100	104	20	30	28	30.0	6	22.8	1.6	
24 23 250	1	50	100	104	25	36	28	30.0	8	28.3	1.5	
24 25 250	1	50	100	104	35	48	28	30.0	10	38.3	1.5	
24 27 250	1	50	100	104	45	58	28	30.0	14	48.8	1.4	
24 26 450	3	50	100	104	45	68	28	65.0	14	48.8	2.0	80 80 068
24 23 256	1	56	112	116	25	36	28	30.0	8	28.3	1.9	
24 25 256	1	56	112	116	35	48	28	30.0	10	38.3	1.8	
24 23 263	1	63	126	130	25	36	28	30.0	8	28.3	2.5	
24 25 271	1	71	142	146	35	48	28	30.0	10	38.3	3.15	
24 25 280	1	80	160	164	35	48	28	30.0	10	38.3	4.2	
24 27 290	1	90	180	184	45	58	28	30.0	14	48.8	5.7	





Straight Tooth System, with Bore ØH6 and Keyway acc. to DIN 6885

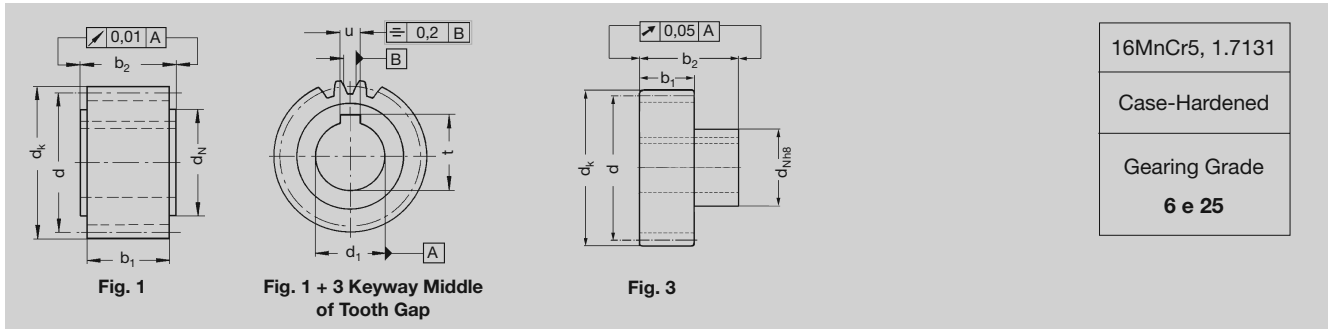

16MnCr5, 1.7131
Case-Hardened
Gearing Grade
6 e 25

Order Code	Fig.	N° of Teeth z	d	dk	d ₁ ^{H6}	d _N	b ₁	b ₂	u	t	kg	Shrink-Disk on Page GH-1
Module 3												
24 33 218	1	18	54	60	25	36	28	30.0	8	28.3	0.4	
24 33 220	1	20	60	66	25	36	28	30.0	8	28.3	0.5	
24 34 220	1	20	60	66	30	45	28	30.0	8	33.3	0.5	
24 35 220	1	20	60	66	35	48	28	30.0	10	38.3	0.4	
24 30 422	3	22	66	72	22	36	28	56.0	6	24.8	0.8	80 84 036
24 31 422	3	22	66	72	25	44	28	60.0	8	28.3	0.9	80 80 044
24 33 222	1	22	66	72	25	36	28	30.0	8	28.3	0.6	
24 32 422	3	22	66	72	30	50	28	60.0	8	33.3	0.9	80 85 050
24 34 222	1	22	66	72	30	45	28	30.0	8	33.3	0.6	
24 33 422	3	22	66	72	32	55	28	65.0	10	35.3	1.0	80 80 055
24 34 422	3	22	66	72	35	55	28	65.0	10	38.3	0.9	80 80 055
24 35 222	1	22	66	72	35	48	28	30.0	10	38.3	0.6	
24 35 422	3	22	66	72	40*	62	28	65	12	43.3	1.0	80 86 062
24 33 225	1	25	75	81	25	36	28	30.0	8	28.3	0.9	
24 34 225	1	25	75	81	30	45	28	30.0	8	33.3	0.8	
24 33 425	3	25	75	81	32*	55	28	65	10	35.3	1.2	80 80 055
24 35 225	1	25	75	81	35	48	28	30.0	10	38.3	0.8	
24 35 425	3	25	75	81	40	62	28	65.0	12	43.3	1.2	80 86 062
24 37 225	1	25	75	81	45	58	28	30.0	14	48.8	0.6	
24 30 428	3	28	84	90	22	36	28	56.0	6	24.8	1.3	80 84 036
24 31 428	3	28	84	90	25	44	28	60.0	8	28.3	1.4	80 80 044
24 33 228	1	28	84	90	25	36	28	30.0	8	28.3	1.1	
24 32 428	3	28	84	90	30	50	28	60.0	8	33.3	1.4	80 85 050
24 34 228	1	28	84	90	30	45	28	30.0	8	33.3	1.1	
24 33 428	3	28	84	90	32	55	28	65.0	10	35.3	1.5	80 80 055
24 34 428	3	28	84	90	35	55	28	65.0	10	38.3	1.4	80 80 055
24 35 228	1	28	84	90	35	48	28	30.0	10	38.3	1.0	
24 35 428	3	28	84	90	40*	62	28	65	12	43.3	1.4	80 86 062
24 36 428	3	28	84	90	45	68	28	65.0	14	48.8	1.5	80 80 068
24 37 228	1	28	84	90	45	58	28	30.0	14	48.8	0.9	
24 33 232	1	32	96	102	25	36	28	30.0	8	28.3	1.5	
24 34 232	1	32	96	102	30	45	28	30.0	8	33.3	1.4	
24 33 432	3	32	96	102	32*	55	28	65	10	35.3	1.8	80 80 055
24 35 232	1	32	96	102	35	48	28	30.0	10	38.3	1.4	
24 35 432	3	32	96	102	40	62	28	65.0	12	43.3	1.8	80 86 062
24 37 232	1	32	96	102	45	58	28	30.0	14	48.8	1.3	
24 39 232	1	32	96	102	60	80	28	30.0	18	64.4	1.1	
24 33 236	1	36	108	114	25	36	28	30.0	8	28.3	1.9	
24 35 236	1	36	108	114	35	48	28	30.0	10	38.3	1.8	
24 36 436	3	36	108	114	45	68	28	65.0	14	48.8	2.2	80 80 068
24 37 236	1	36	108	114	45	58	28	30.0	14	48.8	1.7	
24 39 236	1	36	108	114	60	80	28	30.0	18	64.4	1.4	
24 33 240	1	40	120	126	25	36	28	30	8	28.3	2.3	
24 35 240	1	40	120	126	35	48	28	30.0	10	38.3	2.3	
24 37 240	1	40	120	126	45	58	28	30.0	14	48.8	2.1	
24 39 240	1	40	120	126	60	80	28	30.0	18	64.4	1.9	
24 33 245	1	45	135	141	25	36	28	30.0	8	28.3	3.0	
24 35 245	1	45	135	141	35	48	28	30.0	10	38.3	2.7	
24 37 245	1	45	135	141	45	58	28	30.0	14	48.8	2.4	

* H7 tolerance





Straight Tooth System, with Bore \varnothing H6 and Keyway acc. to DIN 6885

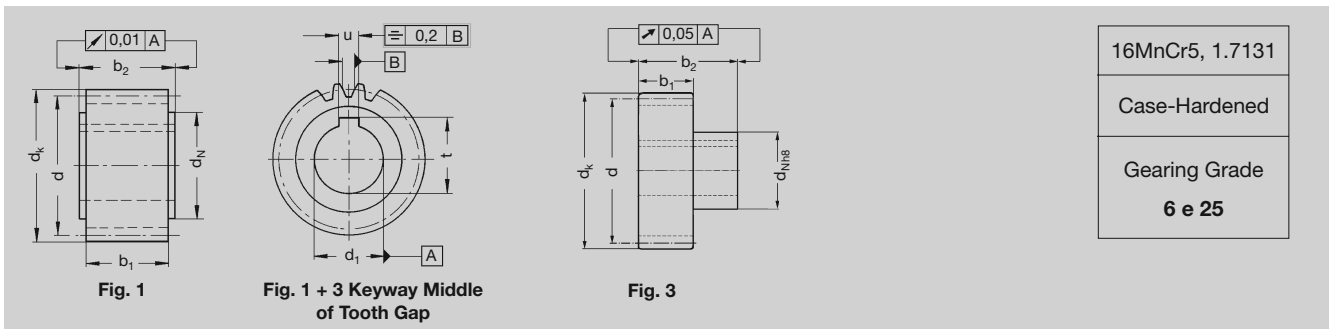

Order Code	Fig.	N° of Teeth z	d	d _k	d ₁ ^{H6}	d _N	b ₁	b ₂	u	t	kg	Shrink-Disk on Page GH-1
Module 3												
24 39 245	1	45	135	141	60	80	28	30.0	18	64.4	2.4	
24 35 250	1	50	150	156	35	48	28	30.0	10	38.3	3.6	
24 37 250	1	50	150	156	45	58	28	30	14	48.8	3.5	
24 37 256	1	56	168	174	45	58	28	30.0	14	48.8	4.4	
24 37 263	1	63	189	195	45	58	28	30.0	14	48.8	5.4	
24 39 263	1	63	189	195	60	80	28	30.0	18	64.4	5.4	





Straight Tooth System, with Bore ØH6 and Keyway acc. to DIN 6885

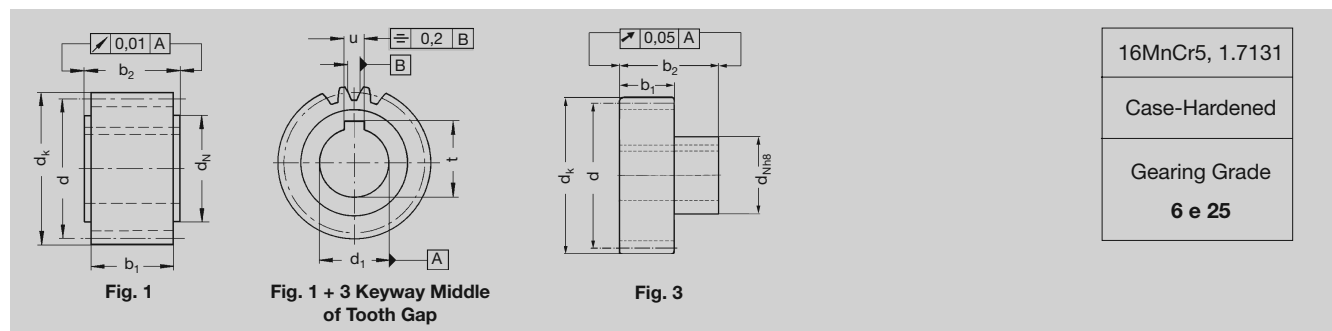

16MnCr5, 1.7131
Case-Hardened
Gearing Grade 6 e 25

Order Code	Fig.	N° of Teeth z	d	d _k	d ₁ ^{H6}	d _N	b ₁	b ₂	u	t	kg	Shrink-Disk on Page GH-1
Module 4												
24 43 420	3	20	80	88	32	55	40	75.0	10	35.3	1.7	80 80 055
24 45 220	1	20	80	88	35	52	40	50.0	10	38.3	1.3	
24 44 420	3	20	80	88	35	55	40	75.0	10	38.3	1.7	80 80 055
24 45 420	3	20	80	88	40	62	40	75.0	12	43.3	1.7	80 86 062
24 47 220	1	20	80	88	45	65	40	50.0	14	48.8	1.2	
24 45 222	1	22	88	96	35	52	40	50.0	10	38.3	1.7	
24 47 222	1	22	88	96	45	65	40	50.0	14	48.8	1.5	
24 46 422	3	22	88	96	45	68	40	75.0	14	48.8	2.0	80 80 068
24 43 425	3	25	100	108	32	55	40	75.0	10	35.3	2.6	80 80 055
24 45 225	1	25	100	108	35	52	40	50.0	10	38.3	2.2	
24 44 425	3	25	100	108	35	55	40	75.0	10	38.3	2.5	80 80 055
24 45 425	3	25	100	108	40	62	40	75.0	12	43.3	2.5	80 86 062
24 47 225	1	25	100	108	45	65	40	50.0	14	48.8	2.0	
24 47 425	3	25	100	108	55	80	40	80.0	16	59.3	2.5	80 87 080
24 45 228	1	28	112	120	35	52	40	50.0	10	38.3	2.9	
24 47 228	1	28	112	120	45	65	40	50.0	14	48.8	2.7	
24 46 428	3	28	112	120	45	68	40	75.0	14	48.8	3.1	80 80 068
24 45 232	1	32	128	136	35	52	40	50.0	10	38.3	3.8	
24 47 232	1	32	128	136	45	65	40	50.0	14	48.8	3.7	
24 47 432	3	32	128	136	55	80	40	80.0	16	59.3	4.1	80 87 080
24 48 432	3	32	128	136	75	110	40	100.0	20	79.9	5.0	80 80 110
24 47 240	1	40	160	168	45	65	40	50.0	14	48.8	5.9	
24 49 240	1	40	160	168	60	80	40	50.0	18	64.4	5.6	
24 48 440	3	40	160	168	75	110	40	100.0	20	79.9	7.3	80 80 110





Straight Tooth System, with Bore $\varnothing H6$ and Keyway acc. to DIN 6885

Keyway Middle of Tooth Gap

16MnCr5, 1.7131

Case-Hardened

Gearing Grade

6 e 25

Order Code	Fig.	N° of Teeth z	d	dk	d ₁ ^{H6}	d _N	b ₁	b ₂	u	t	kg	Shrink-Disk on Page GH-1
Module 5												
24 56 421		21	105	115	45	68	50	85.0	14	48.8	3.7	80 80 068
24 57 421		21	105	115	55	80	50	90.0	16	59.3	3.7	80 87 080
24 56 425		25	125	135	45	68	50	85.0	14	48.8	5.2	80 80 068
24 57 425		25	125	135	55	80	50	90.0	16	59.3	5.1	80 87 080
24 58 425		25	125	135	75	110	50	110.0	20	80.4	4.7	80 80 110
Module 6												
24 67 421		21	126	138	55	80	60	100.0	16	59.3	5.6	80 87 080
24 68 421		21	126	138	75	110	60	120.0	20	79.9	4.7	80 80 110
24 67 425		25	150	162	55	80	60	100.0	16	59.3	8.0	80 87 080
24 68 425		25	150	162	75	110	60	120.0	20	79.9	7.1	80 80 110
Module 8												
24 88 420*		20	160	176	75	110	80	140	20	79.9	12.0	80 80 110
24 89 420*		20	160	176	85	125	80	145	22	90.4	12.1	80 80 125
Module 10												
24 09 620*		20	200	220	85	125	100	165	22	90.4	23	80 80 125

* Gearing quality 5 f 23





Straight Tooth System, 20° Pressure Angle, without Bore

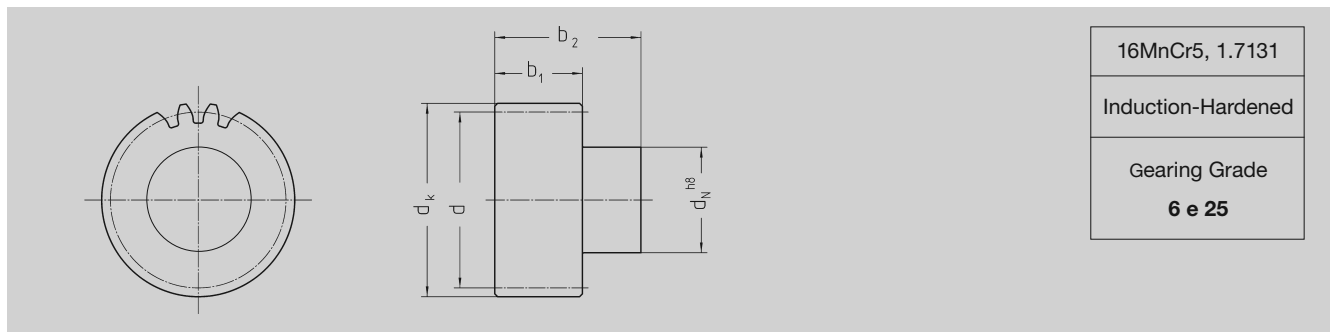

Order Code	Module	N° of Teeth	d	d _k	d _N	b ₁	b ₂	kg	Shrink-Disk on Page GH-1
24 98 218	2	18	36	40	30	28	56	0.3	80 83 030
24 98 220	2	20	40	44	30	28	56	0.4	80 83 030
24 98 222	2	22	44	48	36	28	56	0.5	80 84 036
24 98 225	2	25	50	54	44	28	60	0.7	80 80 044
24 98 228	2	28	56	60	50	28	60	0.9	80 85 050
24 98 230	2	30	60	64	50	28	60	1.0	80 85 050
24 98 232	2	32	64	68	55	28	65	1.3	80 80 055
24 98 236	2	36	72	76	62	28	65	1.6	80 86 062
24 98 240	2	40	80	84	68	28	65	2.0	80 80 068
24 98 318	3	18	54	60	44	28	60	0.8	80 80 044
24 98 320	3	20	60	66	50	28	60	1.0	80 85 050
24 98 322	3	22	66	72	55	28	65	1.3	80 80 055
24 98 325	3	25	75	81	62	28	65	1.7	80 86 062
24 98 328	3	28	84	90	68	28	65	2.1	80 80 068
24 98 330	3	30	90	96	68	28	65	2.2	80 80 068
24 98 332	3	32	96	102	68	28	65	2.4	80 80 068
24 98 336	3	36	108	114	68	28	65	2.8	80 80 068
24 98 340	3	40	120	126	68	28	65	3.3	80 80 068
24 98 418	4	18	72	80	55	40	77	1.7	80 80 055
24 98 420	4	20	80	88	62	40	77	2.2	80 86 062
24 98 422	4	22	88	96	68	40	77	2.7	80 80 068
24 98 425	4	25	100	108	80	40	80	3.7	80 87 080
24 98 428	4	28	112	120	80	40	80	4.4	80 87 080
24 98 430	4	30	120	128	80	40	80	4.6	80 87 080
24 98 432	4	32	128	136	110	40	100	7.9	80 80 110
24 98 436	4	36	144	152	110	40	100	8.9	80 80 110
24 98 440	4	40	160	168	110	40	100	9.9	80 80 110
24 98 521	5	21	105	115	80	50	90	4.9	80 87 080
24 98 522	5	22	110	120	80	50	90	5.0	80 87 080
24 98 525	5	25	125	135	110	50	110	9.0	80 80 110
24 98 528	5	28	140	150	110	50	110	10.2	80 80 110
24 98 530	5	30	150	160	110	50	110	10.9	80 80 110
24 98 621	6	21	126	138	110	60	120	5.9	80 80 110
24 98 625	6	25	150	162	110	60	120	8.9	80 80 110

The pinion could be fixed at d_k or d_n to be reworked (see page ZF-10).

Maximum bore diameter of the pinion on request.





Straight Tooth System, prebored

Fig. 1

Fig. 2

Soft

C45,
1.0503

Gearing Grade

8 e 25

Order Code	Fig.	N° of Teeth z	d	d _k	d ₁	d _N	d ₃	s	kg
21 10 012	1	12	12.0	14.0	6	9	–	–	0.01
21 10 013	1	13	13.0	15.0	6	9	–	–	0.01
21 10 014	1	14	14.0	16.0	6	11	–	–	0.02
21 10 015	1	15	15.0	17.0	6	12	–	–	0.02
21 10 016	1	16	16.0	18.0	6	12	–	–	0.03
21 10 017	1	17	17.0	19.0	6	14	–	–	0.03
21 10 018	1	18	18.0	20.0	6	15	–	–	0.04
21 10 019	1	19	19.0	21.0	6	15	–	–	0.04
21 10 020	1	20	20.0	22.0	6	16	–	–	0.05
21 10 021	1	21	21.0	23.0	6	16	–	–	0.05
21 10 022	1	22	22.0	24.0	6	18	–	–	0.06
21 10 023	1	23	23.0	25.0	6	18	–	–	0.06
21 10 024	1	24	24.0	26.0	9	20	–	–	0.07
21 10 025	1	25	25.0	27.0	9	20	–	–	0.07
21 10 030	1	30	30.0	32.0	9	20	–	–	0.10
21 10 035	1	35	35.0	37.0	9	25	–	–	0.14
21 10 038	1	38	38.0	40.0	9	25	–	–	0.17
21 10 040	1	40	40.0	42.0	9	25	–	–	0.18
21 10 045	1	45	45.0	47.0	9	30	–	–	0.25
21 10 048	1	48	48.0	50.0	9	30	–	–	0.26
21 10 050	1	50	50.0	52.0	9	30	–	–	0.28
21 10 057	1	57	57.0	59.0	9	40	–	–	0.37
21 10 060	1	60	60.0	62.0	9	40	–	–	0.40
23 10 076	2	76	76.0	78.0	10	–	–	–	0.55
23 10 080	2	80	80.0	82.0	10	–	–	–	0.60
23 10 095	2	95	95.0	97.0	10	–	–	–	0.85
23 10 100	2	100	100.0	102.0	10	–	–	–	0.95
23 10 114	2	114	114.0	116.0	10	–	–	–	1.20

Further finishing (turning bores, keywaying, threading, etc.) is possible within short time.

Highlighted items will become obsolete in the future. Please check with the factory for delivery information.





Straight Tooth System, prebored

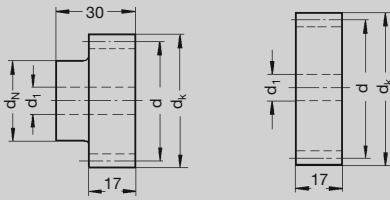

Fig. 1

Fig. 2

Soft
C45, 1.0503
Gearing Grade
8 e 25

Order Code	Fig.	N° of Teeth z	d	dk	d ₁	d _N	d ₃	s	kg
21 15 012	1	12	18.0	21.0	6	14	–	–	0.03
21 15 013	1	13	19.5	22.5	6	14	–	–	0.03
21 15 014	1	14	21.0	24.0	6	16	–	–	0.04
21 15 015	1	15	22.5	25.5	6	18	–	–	0.05
21 15 016	1	16	24.0	27.0	6	18	–	–	0.07
21 15 017	1	17	25.5	28.5	9	20	–	–	0.08
21 15 018	1	18	27.0	30.0	9	20	–	–	0.09
21 15 019	1	19	28.5	31.5	9	20	–	–	0.10
21 15 020	1	20	30.0	33.0	9	25	–	–	0.13
21 15 021	1	21	31.5	34.5	9	25	–	–	0.14
21 15 022	1	22	33.0	36.0	9	25	–	–	0.15
21 15 023	1	23	34.5	37.5	9	25	–	–	0.16
21 15 024	1	24	36.0	39.0	9	25	–	–	0.17
21 15 025	1	25	37.5	40.5	9	25	–	–	0.18
21 15 030	1	30	45.0	48.0	9	30	–	–	0.23
21 15 035	1	35	52.5	55.5	9	40	–	–	0.40
21 15 038	1	38	57.0	60.0	9	40	–	–	0.40
21 15 040	1	40	60.0	63.0	9	40	–	–	0.46
21 15 045	1	45	67.5	70.5	12	50	–	–	0.61
21 15 048	1	48	72.0	75.0	12	50	–	–	0.70
21 15 050	1	50	75.0	78.0	12	50	–	–	0.75
21 15 057	1	57	85.5	88.5	12	60	–	–	1.00
21 15 060	1	60	90.0	93.0	12	60	–	–	1.16
23 15 076	2	76	114.0	117.0	16	–	–	–	1.40
23 15 080	2	80	120.0	123.0	16	–	–	–	1.50
23 15 595	2	95	142.5	145.5	20	–	–	–	2.10

Further finishing (turning bores, keywaying, threading, etc.) is possible within short time.

Highlighted items will become obsolete in the future. Please check with the factory for delivery information.





Straight Tooth System, prebored

Fig. 1

Fig. 2

Soft

C45,
1.0503

Gearing Grade

8 e 25

Order Code	Fig.	N° of Teeth z	d	d _k	d ₁	d _N	d ₃	s	kg
21 20 012	1	12	24.0	28.0	9	18.0	–	–	0.07
21 20 013	1	13	26.0	30.0	9	19.0	–	–	0.12
21 20 014	1	14	28.0	32.0	9	19.0	–	–	0.14
21 20 015	1	15	30.0	34.0	9	24.5	–	–	0.15
21 20 016	1	16	32.0	36.0	9	25.0	–	–	0.17
21 20 017	1	17	34.0	38.0	9	25.0	–	–	0.18
21 20 018	1	18	36.0	40.0	9	25.0	–	–	0.19
21 20 019	1	19	38.0	42.0	9	25.0	–	–	0.20
21 20 020	1	20	40.0	44.0	9	30.0	–	–	0.22
21 20 021	1	21	42.0	46.0	9	30.0	–	–	0.26
21 20 022	1	22	44.0	48.0	9	30.0	–	–	0.27
21 20 023	1	23	46.0	50.0	9	30.0	–	–	0.28
21 20 024	1	24	48.0	52.0	12	35.0	–	–	0.36
21 20 025	1	25	50.0	54.0	12	35.0	–	–	0.39
21 20 028	1	28	56.0	60.0	12	40.0	–	–	0.45
21 20 030	1	30	60.0	64.0	12	40.0	–	–	0.50
21 20 032	1	32	64.0	68.0	12	40.0	–	–	0.60
21 20 035	1	35	70.0	74.0	12	50.0	–	–	0.67
21 20 036	1	36	72.0	76.0	12	50.0	–	–	0.85
21 20 038	1	38	76.0	80.0	12	50.0	–	–	0.90
21 20 040	1	40	80.0	84.0	12	50.0	–	–	0.95
21 20 045	1	45	90.0	94.0	12	60.0	–	–	1.25
21 20 048	1	48	96.0	100.0	15	70.0	–	–	1.50
21 20 050	1	50	100.0	104.0	15	70.0	–	–	1.60
21 20 056	1	56	112.0	116.0	15	70.0	–	–	1.90
21 20 057	1	57	114.0	118.0	15	70.0	–	–	2.00
21 20 060	1	60	120.0	124.0	15	70.0	–	–	2.40
23 20 576	2	76	152.0	156.0	20	–	–	–	2.80
23 20 580	2	80	160.0	164.0	20	–	–	–	3.10
23 20 595	2	95	190.0	194.0	20	–	–	–	4.40

Further finishing (turning bores, keywaying, threading, etc.) is possible within short time.

Highlighted items will become obsolete in the future. Please check with the factory for delivery information.



Straight Tooth System, prebored

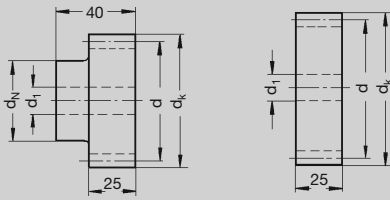

Fig. 1

Fig. 2

Soft
C45, 1.0503
Gearing Grade
8 e 25

Order Code	Fig.	N° of Teeth z	d	d _k	d ₁	d _N	d ₃	s	kg
21 25 012	1	12	30.0	35.0	9	20.0	–	–	0.16
21 25 013	1	13	32.5	37.5	9	20.0	–	–	0.18
21 25 014	1	14	35.0	40.0	9	25.0	–	–	0.22
21 25 015	1	15	37.5	42.5	9	25.0	–	–	0.25
21 25 016	1	16	40.0	45.0	9	30.0	–	–	0.31
21 25 017	1	17	42.5	47.5	9	30.0	–	–	0.35
21 25 018	1	18	45.0	50.0	9	35.0	–	–	0.41
21 25 019	1	19	47.5	52.5	12	35.0	–	–	0.43
21 25 020	1	20	50.0	55.0	12	35.0	–	–	0.47
21 25 021	1	21	52.5	57.5	12	35.0	–	–	0.50
21 25 022	1	22	55.0	60.0	12	40.0	–	–	0.53
21 25 023	1	23	57.5	62.5	12	40.0	–	–	0.62
21 25 024	1	24	60.0	65.0	12	40.0	–	–	0.66
21 25 025	1	25	62.5	67.5	12	45.0	–	–	0.75
21 25 030	1	30	75.0	80.0	12	50.0	–	–	0.97
21 25 035	1	35	87.5	92.5	12	60.0	–	–	1.49
21 25 038	1	38	95.0	100.0	12	60.0	–	–	1.72
21 25 040	1	40	100.0	105.0	12	70.0	–	–	1.84
21 25 045	1	45	112.5	117.5	15	70.0	–	–	2.36
21 25 048	1	48	120.0	125.0	15	80.0	–	–	2.75
21 25 050	1	50	125.0	130.0	15	80.0	–	–	2.94
21 25 057	1	57	142.5	147.5	15	90.0	–	–	3.67
21 25 060	1	60	150.0	155.0	15	90.0	–	–	4.00
23 25 580	2	80	200.0	205.0	25	–	–	–	6.10

Further finishing (turning bores, keywaying, threading, etc.) is possible within short time.

Highlighted items will become obsolete in the future. Please check with the factory for delivery information.





Straight Tooth System, prebored

Fig. 1

Fig. 2

Soft

C45,
1.0503

Gearing Grade

8 e 25

Order Code	Fig.	N° of Teeth z	d	dk	d ₁	d _N	d ₃	s	kg
21 30 012	1	12	36	42	14	25	–	–	0.25
21 30 013	1	13	39	45	14	25	–	–	0.30
21 30 014	1	14	42	48	14	25	–	–	0.34
21 30 015	1	15	45	51	14	35	–	–	0.41
21 30 016	1	16	48	54	14	35	–	–	0.51
21 30 017	1	17	51	57	14	42	–	–	0.67
21 30 018	1	18	54	60	14	45	–	–	0.70
21 30 019	1	19	57	63	14	45	–	–	0.75
21 30 020	1	20	60	66	14	45	–	–	0.82
21 30 021	1	21	63	69	14	45	–	–	0.89
21 30 022	1	22	66	72	14	50	–	–	1.05
21 30 023	1	23	69	75	14	50	–	–	1.10
21 30 024	1	24	72	78	14	50	–	–	1.20
21 30 025	1	25	75	81	14	60	–	–	1.35
21 30 027	1	27	81	87	14	60	–	–	1.60
21 30 028	1	28	84	90	14	60	–	–	1.70
21 30 030	1	30	90	96	14	60	–	–	1.80
21 30 032	1	32	96	102	14	60	–	–	2.00
21 30 035	1	35	105	111	14	80	–	–	2.70
21 30 036	1	36	108	114	14	80	–	–	2.80
21 30 038	1	38	114	120	14	80	–	–	3.00
21 30 040	1	40	120	126	14	80	–	–	3.30
23 30 545	2	45	135	141	20	–	–	–	3.30
23 30 548	2	48	144	150	20	–	–	–	3.80
23 30 550	2	50	150	156	25	–	–	–	4.10
23 30 552	2	52	156	162	25	–	–	–	4.50
23 30 556	2	56	168	174	25	–	–	–	5.20
23 30 560	2	60	180	186	25	–	–	–	6.00
23 30 576	2	76	228	234	25	–	–	–	9.60
23 30 595	2	95	285	291	25	–	–	–	15.00

Further finishing (turning bores, keywaying, threading, etc.) is possible within short time.

Highlighted items will become obsolete in the future. Please check with the factory for delivery information.



Straight Tooth System, prebored

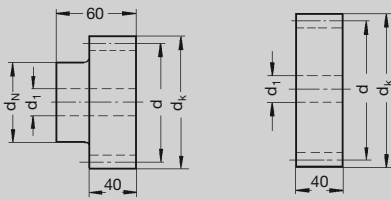

Fig. 1

Fig. 2

Soft
C45, 1.0503
Gearing Grade
8 e 25

Order Code	Fig.	N° of Teeth z	d	d _k	d ₁	d _N	d ₃	s	kg
21 40 012	1	12	48	56	16	35	–	–	0.58
21 40 013	1	13	52	60	16	35	–	–	0.72
21 40 014	1	14	56	64	16	45	–	–	0.90
21 40 015	1	15	60	68	16	45	–	–	1.00
21 40 016	1	16	64	72	16	45	–	–	1.10
21 40 017	1	17	68	76	16	50	–	–	1.30
21 40 018	1	18	72	80	16	50	–	–	1.40
21 40 019	1	19	76	84	16	60	–	–	1.70
21 40 020	1	20	80	88	16	60	–	–	1.80
21 40 021	1	21	84	92	16	70	–	–	2.20
21 40 022	1	22	88	96	16	70	–	–	2.50
21 40 023	1	23	92	100	16	75	–	–	2.60
21 40 024	1	24	96	104	16	75	–	–	2.75
21 40 025	1	25	100	108	16	75	–	–	2.90
21 40 030	1	30	120	128	16	75	–	–	4.00
23 40 538	2	38	152	160	25	–	–	–	5.70
23 40 540	2	40	160	168	25	–	–	–	6.30
23 40 545	2	45	180	188	25	–	–	–	8.00
23 40 550	2	50	200	208	25	–	–	–	9.80
23 40 556	2	56	224	232	25	–	–	–	12.30
23 40 560	2	60	240	248	25	–	–	–	14.20
23 40 580	2	80	320	328	25	–	–	–	25.20
23 40 595	2	95	380	388	25	–	–	–	35.60

Further finishing (turning bores, keywaying, threading, etc.) is possible within short time.

Highlighted items will become obsolete in the future. Please check with the factory for delivery information.





Straight Tooth System, prebored

Fig. 1

Fig. 2

Soft

C45,
1.0503

Gearing Grade

8 e 25

Order Code	Fig.	N° of Teeth z	d	d _k	d ₁	d _N	d ₃	s	kg
21 50 012	1	12	60	70	20	45	–	–	1.20
21 50 013	1	13	65	75	20	45	–	–	1.38
21 50 014	1	14	70	80	20	55	–	–	1.78
21 50 015	1	15	75	85	20	60	–	–	2.00
21 50 016	1	16	80	90	20	60	–	–	2.10
21 50 017	1	17	85	95	20	70	–	–	2.20
21 50 018	1	18	90	100	20	70	–	–	2.58
21 50 019	1	19	95	105	20	70	–	–	2.80
21 50 020	1	20	100	110	20	70	–	–	3.10
21 50 021	1	21	105	115	20	70	–	–	3.80
21 50 022	1	22	110	120	20	80	–	–	4.30
21 50 023	1	23	115	125	20	80	–	–	4.70
21 50 024	1	24	120	130	20	80	–	–	5.00
21 50 025	1	25	125	135	20	80	–	–	5.40
21 50 030	1	30	150	160	20	90	–	–	7.70
23 50 536	2	36	180	190	30	–	–	–	9.90
23 50 540	2	40	200	210	30	–	–	–	12.30
23 50 550	2	50	250	260	30	–	–	–	19.20
23 50 595	2	95	475	485	30	–	–	–	69.50

Further finishing (turning bores, keywaying, threading, etc.) is possible within short time.

Highlighted items will become obsolete in the future. Please check with the factory for delivery information.





Module 6, Straight Tooth System, prebored

Fig. 1

Fig. 2

Soft

C45,
1.0503

Gearing Grade

8 e 25

Order Code	Fig.	N° of Teeth z	d	dk	d1	dN	d3	s	kg
21 60 015	1	15	90	102	20	60	–	–	3.20
21 60 019	1	19	114	126	20	80	–	–	5.40
21 60 020	1	20	120	132	20	90	–	–	6.00
21 60 021	1	21	126	138	20	90	–	–	6.70
21 60 022	1	22	132	144	20	100	–	–	7.40
21 60 025	1	25	150	162	20	110	–	–	9.60
23 60 530	2	30	180	192	30	–	–	–	11.90
23 60 536	2	36	216	228	30	–	–	–	17.20

Further finishing (turning bores, keywaying, threading, etc.) is possible within short time.

Highlighted items will become obsolete in the future. Please check with the factory for delivery information.

Module 8, 10 and 12, Straight Tooth System, prebored

Fig. 1

Fig. 2

Fig. 3

Soft

C45,
1.0503

Gearing Grade

8 e 25

Order Code	Fig.	N° of Teeth z	d	dk	d1	dN	d3	s	kg
Module 8									
21 80 015	1	15	120	136	40	90	–	–	7.70
21 80 018	1	18	144	160	40	100	–	–	9.90
21 80 020	1	20	160	176	40	120	–	–	14.80
21 80 024	1	24	192	208	40	150	–	–	22.00
21 80 025	1	25	200	216	40	150	–	–	23.80
21 80 030	1	30	240	256	40	190	–	–	32.00
Module 10*									
21 11 020	2	20	200	220	40	150	–	–	35.00
Module 12*									
21 12 020	3	20	240	264	40	170	–	–	51.33

* with threads for handling

Further finishing (turning bores, keywaying, threading, etc.) is possible within short time.





ATLANTA

Rack and Pinion Drive – Calculation and Selection – Module 1 – Straight Tooth System

Rack	Quality	BR	
		9	10
Rack	Material	C45	C45
	Heat Treatment	Soft	Ind. Hardened
Pinion	Material	C45	C45
	Heat Treatment	Soft	Ind. Hardened
No. of Pinion Teeth ¹⁾	Pitch Circle Dia.	Maximum Feed Force	
12	12 mm	0.1 kN	0.6 kN
13	13 mm	0.1 kN	0.7 kN
14	14 mm	0.1 kN	0.8 kN
15	15 mm	0.2 kN	0.9 kN
16	16 mm	0.2 kN	1.0 kN
17	17 mm	0.2 kN	1.0 kN
18	18 mm	0.2 kN	1.0 kN
19	19 mm	0.3 kN	1.0 kN
20	20 mm	0.3 kN	1.0 kN
21	21 mm	0.3 kN	1.0 kN
22	22 mm	0.3 kN	1.5 kN
23	23 mm	0.4 kN	1.5 kN
24	24 mm	0.4 kN	1.5 kN
25	25 mm	0.4 kN	1.5 kN
26	26 mm	0.4 kN	1.5 kN
27	27 mm	0.4 kN	1.5 kN
28	28 mm	0.5 kN	1.5 kN
29	29 mm	0.5 kN	1.5 kN
30	30 mm	0.5 kN	1.5 kN
31	31 mm	0.5 kN	2.0 kN
32	32 mm	0.6 kN	2.0 kN
33	33 mm	0.6 kN	2.0 kN
34	34 mm	0.6 kN	2.0 kN
35	35 mm	0.6 kN	2.0 kN
36	36 mm	0.6 kN	2.0 kN
37	37 mm	0.7 kN	2.0 kN
38	38 mm	0.7 kN	2.0 kN
39	39 mm	0.7 kN	2.0 kN
40	40 mm	0.7 kN	2.0 kN

Maximum permissible Feed Forces¹⁾ in kN

which are achieved with good grease lubrication (i.e. use of the electronic lubricator described on page ZE-2/3 or manual lubrication at least once a day) and $v=1.5$ m/s, $S_B=1.0$ as well as a linear load distribution factor of 1.0.

The values in the Load Tables are maximum values under perfect conditions and is a guide value.

A calculation of the application and configuration is in any cases needed.

Calculation and example see page ZD-2.

1) For keyway transmission make a separate calculation, torque with shrink disk see on page GH-1

When using the maximum capacity of the teeth, or multiple pinions in contact, the mounting screw loads must be checked separately!

1) Check availability (chapter ZB)



ATLANTA

Rack and Pinion Drive – Calculation and Selection – Module 1.5 – Straight Tooth System

Rack		BR	
Quality		9	10
Rack	Material	C45	C45
	Heat Treatment	Soft	Ind. Hardened
Pinion	Material	C45	C45
	Heat Treatment	Soft	Ind. Hardened
No. of Pinion Teeth ¹⁾	Pitch Circle Dia.	Maximum Feed Force	
12	18.0 mm	0.2 kN	1.0 kN
13	19.5 mm	0.2 kN	1.0 kN
14	21.0 mm	0.3 kN	1.0 kN
15	22.5 mm	0.3 kN	1.5 kN
16	24.0 mm	0.3 kN	1.5 kN
17	25.5 mm	0.4 kN	1.5 kN
18	27.0 mm	0.4 kN	2.0 kN
19	28.5 mm	0.5 kN	2.0 kN
20	30.0 mm	0.5 kN	2.0 kN
21	31.5 mm	0.6 kN	2.5 kN
22	33.0 mm	0.6 kN	2.5 kN
23	34.5 mm	0.6 kN	2.5 kN
24	36.0 mm	0.7 kN	3.0 kN
25	37.5 mm	0.7 kN	3.0 kN
26	39.0 mm	0.8 kN	3.0 kN
27	40.5 mm	0.8 kN	3.0 kN
28	42.0 mm	0.8 kN	3.0 kN
29	43.5 mm	0.9 kN	3.0 kN
30	45.0 mm	0.9 kN	3.0 kN
31	46.5 mm	1.0 kN	3.5 kN
32	48.0 mm	1.0 kN	3.5 kN
33	49.5 mm	1.0 kN	3.5 kN
34	51.0 mm	1.0 kN	3.5 kN
35	52.5 mm	1.0 kN	3.5 kN
36	54.0 mm	1.0 kN	3.5 kN
37	55.5 mm	1.0 kN	3.5 kN
38	57.0 mm	1.0 kN	3.5 kN
39	58.5 mm	1.0 kN	3.5 kN
40	60.0 mm	1.0 kN	3.5 kN

1) Check availability (chapter ZB)

Maximum permissible feed forces – description see page ZB-36





ATLANTA

Rack and Pinion Drive – Calculation and Selection – Module 2 – Straight Tooth System

Rack		UHPR	HPR			PR			BR			
Quality		5	6		7	8			9		10	
Rack	Material	16MnCr5	16MnCr5	C45	C45	C45	42CrMo4		C45		C45	
	Heat Treatment	Case Hardened	Induction Hardened		Ind. Hardened	Ind. Hardened	Quenched + Tempered		Soft		Induction Hardened	
Pinion	Material	16MnCr5	16MnCr5	16MnCr5	16MnCr5	16MnCr5	16MnCr5	C45	16MnCr5	C45	16MnCr5	C45
	Heat Treatment	Case Hardened	Case Hardened	Case Hardened	Case Hardened	Case Hardened	Case Hardened	Ind. Hardened	Case Hardened	Soft	Case Hardened	Ind. Hardened
No. of Pinion Teeth ¹⁾	Pitch Circle Dia.	Maximum Feed Force										
12	24 mm	3.5 kN	3.5 kN	3.5 kN	3.5 kN	3.5 kN	1.5 kN	1.0 kN	0.8 kN	0.3 kN	2.5 kN	1.5 kN
13	26 mm	4.5 kN	4.5 kN	4.5 kN	4.5 kN	4.0 kN	1.5 kN	1.0 kN	0.9 kN	0.4 kN	3.0 kN	1.5 kN
14	28 mm	5.5 kN	5.5 kN	5.5 kN	5.5 kN	5.0 kN	2.0 kN	1.0 kN	0.9 kN	0.4 kN	3.5 kN	2.0 kN
15	30 mm	6.5 kN	6.5 kN	6.0 kN	6.0 kN	6.0 kN	2.0 kN	1.5 kN	1.0 kN	0.5 kN	4.0 kN	2.0 kN
16	32 mm	7.0 kN	7.0 kN	7.0 kN	7.0 kN	6.5 kN	2.5 kN	1.5 kN	1.0 kN	0.6 kN	4.5 kN	2.5 kN
17	34 mm	8.0 kN	8.0 kN	7.5 kN	7.5 kN	7.0 kN	2.5 kN	1.5 kN	1.0 kN	0.7 kN	4.5 kN	3.0 kN
18	36 mm	9.0 kN	9.0 kN	8.0 kN	8.0 kN	7.5 kN	3.0 kN	2.0 kN	1.0 kN	0.7 kN	5.0 kN	3.0 kN
19	38 mm	10.0 kN	10.0 kN	8.5 kN	8.5 kN	8.0 kN	3.0 kN	2.0 kN	1.0 kN	0.8 kN	5.0 kN	3.5 kN
20	40 mm	10.5 kN	10.5 kN	9.0 kN	9.0 kN	8.5 kN	3.5 kN	2.0 kN	1.5 kN	0.8 kN	5.5 kN	3.5 kN
21	42 mm	11.5 kN	11.5 kN	9.5 kN	9.5 kN	9.0 kN	3.5 kN	2.0 kN	1.5 kN	0.9 kN	5.5 kN	4.0 kN
22	44 mm	12.0 kN	12.0 kN	10.0 kN	10.0 kN	9.5 kN	3.5 kN	2.5 kN	1.5 kN	1.0 kN	6.0 kN	4.0 kN
23	46 mm	13.0 kN	13.0 kN	10.5 kN	10.5 kN	10.0 kN	4.0 kN	2.5 kN	1.5 kN	1.0 kN	6.0 kN	4.5 kN
24	48 mm	13.5 kN	13.5 kN	11.0 kN	11.0 kN	10.5 kN	4.0 kN	2.5 kN	1.5 kN	1.0 kN	6.5 kN	4.5 kN
25	50 mm	14.5 kN	14.5 kN	11.5 kN	11.5 kN	11.0 kN	4.0 kN	2.5 kN	1.5 kN	1.0 kN	6.5 kN	5.0 kN
26	52 mm	15.0 kN	15.0 kN	12.0 kN	12.0 kN	11.0 kN	4.5 kN	3.0 kN	2.0 kN	1.0 kN	7.0 kN	5.0 kN
27	54 mm	16.0 kN	15.0 kN	12.0 kN	12.0 kN	11.5 kN	4.5 kN	3.0 kN	2.0 kN	1.0 kN	7.0 kN	5.0 kN
28	56 mm	16.5 kN	15.0 kN	12.0 kN	12.0 kN	11.5 kN	5.0 kN	3.0 kN	2.0 kN	1.0 kN	7.0 kN	5.5 kN
29	58 mm	16.5 kN	15.0 kN	12.5 kN	12.5 kN	11.5 kN	5.0 kN	3.0 kN	2.0 kN	1.0 kN	7.0 kN	5.5 kN
30	60 mm	16.5 kN	15.0 kN	12.5 kN	12.5 kN	11.5 kN	5.0 kN	3.5 kN	2.0 kN	1.5 kN	7.0 kN	5.5 kN
31	62 mm	16.5 kN	15.0 kN	12.5 kN	12.5 kN	11.5 kN	5.5 kN	3.5 kN	2.0 kN	1.5 kN	7.0 kN	5.5 kN
32	64 mm	16.5 kN	15.5 kN	12.5 kN	12.5 kN	11.5 kN	5.5 kN	3.5 kN	2.5 kN	1.5 kN	7.0 kN	5.5 kN
33	66 mm	16.5 kN	15.5 kN	12.5 kN	12.5 kN	11.5 kN	5.5 kN	3.5 kN	2.5 kN	1.5 kN	7.0 kN	5.5 kN
34	68 mm	16.5 kN	15.5 kN	12.5 kN	12.5 kN	12.0 kN	6.0 kN	3.5 kN	2.5 kN	1.5 kN	7.0 kN	5.5 kN
35	70 mm	16.5 kN	15.5 kN	12.5 kN	12.5 kN	12.0 kN	6.0 kN	4.0 kN	2.5 kN	1.5 kN	7.0 kN	5.5 kN
36	72 mm	17.0 kN	15.5 kN	12.5 kN	12.5 kN	12.0 kN	6.5 kN	4.0 kN	2.5 kN	1.5 kN	7.0 kN	5.5 kN
37	74 mm	17.0 kN	15.5 kN	12.5 kN	12.5 kN	12.0 kN	6.5 kN	4.0 kN	2.5 kN	1.5 kN	7.0 kN	5.5 kN
38	76 mm	17.0 kN	15.5 kN	12.5 kN	12.5 kN	12.0 kN	6.5 kN	4.0 kN	3.0 kN	2.0 kN	7.0 kN	5.5 kN
39	78 mm	17.0 kN	15.5 kN	12.5 kN	12.5 kN	12.0 kN	7.0 kN	4.5 kN	3.0 kN	2.0 kN	7.0 kN	5.5 kN
40	80 mm	17.0 kN	15.5 kN	12.5 kN	12.5 kN	12.0 kN	7.0 kN	4.5 kN	3.0 kN	2.0 kN	7.0 kN	5.5 kN

1) Check availability (chapter ZB)

Maximum permissible feed forces – description see page ZB-36



ATLANTA

Rack and Pinion Drive – Calculation and Selection – Module 2.5 – Straight Tooth System

Rack		BR	
Quality		9	10
Rack	Material	C45	C45
	Heat Treatment	Soft	Ind. Hardened
Pinion	Material	C45	C45
	Heat Treatment	Soft	Ind. Hardened
No. of Pinion Teeth ¹⁾	Pitch Circle Dia.	Maximum Feed Force	
12	30.0 mm	0.5 kN	2.5 kN
13	32.5 mm	0.6 kN	3.0 kN
14	35.0 mm	0.7 kN	3.0 kN
15	37.5 mm	0.8 kN	3.5 kN
16	40.0 mm	0.9 kN	4.0 kN
17	42.5 mm	1.0 kN	4.5 kN
18	45.0 mm	1.0 kN	5.0 kN
19	47.5 mm	1.0 kN	5.5 kN
20	50.0 mm	1.0 kN	5.5 kN
21	52.5 mm	1.5 kN	6.0 kN
22	55.0 mm	1.5 kN	6.5 kN
23	57.5 mm	1.5 kN	7.0 kN
24	60.0 mm	1.5 kN	7.5 kN
25	62.5 mm	1.5 kN	8.0 kN
26	65.0 mm	1.5 kN	8.0 kN
27	67.5 mm	2.0 kN	8.5 kN
28	70.0 mm	2.0 kN	8.5 kN
29	72.5 mm	2.0 kN	8.5 kN
30	75.0 mm	2.0 kN	8.5 kN
31	77.5 mm	2.0 kN	8.5 kN
32	80.0 mm	2.5 kN	8.5 kN
33	82.5 mm	2.5 kN	8.5 kN
34	85.0 mm	2.5 kN	8.5 kN
35	87.5 mm	2.5 kN	8.5 kN
36	90.0 mm	2.5 kN	8.5 kN
37	92.5 mm	3.0 kN	8.5 kN
38	95.0 mm	3.0 kN	8.5 kN
39	97.5 mm	3.0 kN	8.5 kN
40	100.0 mm	3.0 kN	8.5 kN

1) Check availability (chapter ZB)

Maximum permissible feed forces – description see page ZB-36





ATLANTA

Rack and Pinion Drive – Calculation and Selection – Module 3 – Straight Tooth System

Rack		UHPR	HPR			PR			BR			
Quality		5	6		7	8			9		10	
Rack	Material	16MnCr5	16MnCr5	C45	C45	C45	42CrMo4		C45		C45	
	Heat Treatment	Case Hardened	Induction Hardened		Ind. Hardened	Ind. Hardened	Quenched + Tempered		Soft		Induction Hardened	
Pinion	Material	16MnCr5	16MnCr5	16MnCr5	16MnCr5	16MnCr5	16MnCr5	C45	16MnCr5	C45	16MnCr5	C45
	Heat Treatment	Case Hardened	Case Hardened	Case Hardened	Case Hardened	Case Hardened	Case Hardened	Ind. Hardened	Case Hardened	Soft	Case Hardened	Ind. Hardened
No. of Pinion Teeth ¹⁾	Pitch Circle Dia.	Maximum Feed Force										
12	36 mm	6.5 kN	6.5 kN	6.5 kN	6.5 kN	6.0 kN	2.5 kN	2.5 kN	1.5 kN	0.7 kN	5.5 kN	3.5 kN
13	39 mm	7.5 kN	7.5 kN	7.5 kN	7.5 kN	7.0 kN	3.0 kN	2.5 kN	1.5 kN	0.9 kN	6.5 kN	4.0 kN
14	42 mm	9.5 kN	9.5 kN	9.5 kN	9.5 kN	8.5 kN	3.5 kN	3.0 kN	2.0 kN	1.0 kN	8.0 kN	4.5 kN
15	45 mm	11.0 kN	11.0 kN	10.5 kN	10.5 kN	9.5 kN	4.0 kN	3.0 kN	2.0 kN	1.0 kN	8.5 kN	5.5 kN
16	48 mm	12.5 kN	12.5 kN	12.0 kN	11.5 kN	10.5 kN	4.0 kN	3.5 kN	2.0 kN	1.0 kN	9.5 kN	6.0 kN
17	51 mm	14.5 kN	14.5 kN	13.5 kN	13.5 kN	12.0 kN	5.0 kN	4.0 kN	2.5 kN	1.5 kN	10.0 kN	6.5 kN
18	54 mm	16.0 kN	16.0 kN	14.0 kN	14.0 kN	13.0 kN	5.0 kN	4.5 kN	2.5 kN	1.5 kN	10.5 kN	7.0 kN
19	57 mm	17.5 kN	17.5 kN	15.0 kN	15.0 kN	13.5 kN	5.5 kN	4.5 kN	3.0 kN	1.5 kN	11.0 kN	8.0 kN
20	60 mm	18.5 kN	18.5 kN	16.0 kN	16.0 kN	14.5 kN	5.5 kN	5.0 kN	3.0 kN	2.0 kN	11.5 kN	8.5 kN
21	63 mm	20.0 kN	20.0 kN	17.0 kN	17.0 kN	15.0 kN	6.0 kN	5.0 kN	3.0 kN	2.0 kN	12.0 kN	9.0 kN
22	66 mm	21.5 kN	21.5 kN	17.5 kN	17.5 kN	16.0 kN	6.5 kN	5.5 kN	3.5 kN	2.0 kN	13.0 kN	9.5 kN
23	69 mm	22.5 kN	22.5 kN	18.5 kN	18.5 kN	16.5 kN	6.5 kN	5.5 kN	3.5 kN	2.0 kN	13.5 kN	10.0 kN
24	72 mm	24.0 kN	24.0 kN	19.5 kN	19.5 kN	17.5 kN	7.0 kN	6.0 kN	3.5 kN	2.5 kN	14.0 kN	10.5 kN
25	75 mm	24.0 kN	24.0 kN	20.0 kN	20.0 kN	18.5 kN	7.5 kN	6.5 kN	4.0 kN	2.5 kN	14.5 kN	11.5 kN
26	78 mm	24.5 kN	24.5 kN	21.0 kN	21.0 kN	19.0 kN	7.5 kN	6.5 kN	4.0 kN	2.5 kN	15.0 kN	12.0 kN
27	81 mm	24.5 kN	24.5 kN	22.0 kN	22.0 kN	20.0 kN	8.0 kN	7.0 kN	4.0 kN	3.0 kN	15.5 kN	12.0 kN
28	84 mm	24.5 kN	24.5 kN	22.5 kN	22.5 kN	20.5 kN	8.0 kN	7.0 kN	4.5 kN	3.0 kN	16.0 kN	12.5 kN
29	87 mm	25.0 kN	25.0 kN	22.5 kN	22.5 kN	21.0 kN	8.5 kN	7.5 kN	4.5 kN	3.0 kN	16.0 kN	12.5 kN
30	90 mm	25.0 kN	25.0 kN	22.5 kN	22.5 kN	21.0 kN	9.0 kN	7.5 kN	4.5 kN	3.0 kN	16.0 kN	12.5 kN
31	93 mm	25.0 kN	25.0 kN	22.5 kN	22.5 kN	21.0 kN	9.0 kN	8.0 kN	5.0 kN	3.5 kN	16.0 kN	12.5 kN
32	96 mm	25.0 kN	25.0 kN	22.5 kN	22.5 kN	21.5 kN	9.5 kN	8.0 kN	5.0 kN	3.5 kN	16.0 kN	12.5 kN
33	99 mm	25.0 kN	25.0 kN	23.0 kN	23.0 kN	21.5 kN	10.0 kN	8.5 kN	5.5 kN	3.5 kN	16.0 kN	12.5 kN
34	102 mm	25.5 kN	25.5 kN	23.0 kN	23.0 kN	21.5 kN	10.0 kN	9.0 kN	5.5 kN	4.0 kN	16.0 kN	12.5 kN
35	105 mm	25.5 kN	25.5 kN	23.0 kN	23.0 kN	21.5 kN	10.5 kN	9.0 kN	5.5 kN	4.0 kN	16.0 kN	12.5 kN
36	108 mm	25.5 kN	25.5 kN	23.0 kN	23.0 kN	21.5 kN	11.0 kN	9.5 kN	6.0 kN	4.0 kN	16.5 kN	12.5 kN
37	111 mm	25.5 kN	25.5 kN	23.0 kN	23.0 kN	21.5 kN	11.0 kN	9.5 kN	6.0 kN	4.0 kN	16.5 kN	12.5 kN
38	114 mm	25.5 kN	25.5 kN	23.0 kN	23.0 kN	21.5 kN	11.5 kN	10.0 kN	6.0 kN	4.5 kN	16.5 kN	12.5 kN
39	117 mm	25.5 kN	25.5 kN	23.0 kN	23.0 kN	21.5 kN	11.5 kN	10.0 kN	6.5 kN	4.5 kN	16.5 kN	12.5 kN
40	120 mm	25.5 kN	25.5 kN	23.5 kN	23.0 kN	22.0 kN	12.0 kN	10.5 kN	6.5 kN	4.5 kN	16.5 kN	12.5 kN

1) Check availability (chapter ZB)



ATLANTA

Rack and Pinion Drive – Calculation and Selection – Module 4 – Straight Tooth System

Rack		UHRP		HPR			PR			BR		
Quality		5	6		7	8			9	10		
Rack	Material	16MnCr5	16MnCr5	C45	C45	C45	42CrMo4		C45		C45	
	Heat Treatment	Case Hardened	Induction Hardened		Ind. Hardened	Ind. Hardened	Quenched + Tempered		Soft		Induction Hardened	
Pinion	Material	16MnCr5	16MnCr5	16MnCr5	16MnCr5	16MnCr5	16MnCr5	C45	16MnCr5	C45	16MnCr5	C45
	Heat Treatment	Case Hardened	Case Hardened	Case Hardened	Case Hardened	Case Hardened	Case Hardened	Ind. Hardened	Case Hardened	Soft	Case Hardened	Ind. Hardened
No. of Pinion Teeth ¹⁾	Pitch Circle Dia.	Maximum Feed Force										
12	48 mm	12.0 kN	12.0 kN	12.0 kN	12.0 kN	11.5 kN	5.5 kN	4.5 kN	3.0 kN	1.0 kN	11.0 kN	6.5 kN
13	52 mm	14.5 kN	14.5 kN	14.5 kN	14.5 kN	13.5 kN	6.0 kN	4.5 kN	3.5 kN	1.5 kN	13.0 kN	7.5 kN
14	56 mm	18.0 kN	18.0 kN	18.0 kN	18.0 kN	17.0 kN	7.0 kN	5.5 kN	3.5 kN	1.5 kN	15.0 kN	8.5 kN
15	60 mm	20.5 kN	20.0 kN	20.0 kN	20.0 kN	18.5 kN	7.5 kN	6.0 kN	4.0 kN	2.0 kN	17.0 kN	10.0 kN
16	64 mm	23.0 kN	23.0 kN	22.0 kN	22.0 kN	20.5 kN	8.0 kN	6.5 kN	4.5 kN	2.0 kN	18.0 kN	11.0 kN
17	68 mm	27.0 kN	27.0 kN	24.5 kN	24.5 kN	23.0 kN	9.0 kN	7.5 kN	5.0 kN	2.5 kN	19.0 kN	12.0 kN
18	72 mm	30.0 kN	30.0 kN	26.5 kN	26.5 kN	25.0 kN	10.0 kN	8.0 kN	5.5 kN	3.0 kN	20.0 kN	13.0 kN
19	76 mm	32.5 kN	32.5 kN	28.0 kN	28.0 kN	26.0 kN	10.5 kN	8.5 kN	5.5 kN	3.0 kN	21.5 kN	14.0 kN
20	80 mm	35.0 kN	35.0 kN	30.0 kN	30.0 kN	27.5 kN	11.0 kN	9.0 kN	6.0 kN	3.5 kN	22.5 kN	15.0 kN
21	84 mm	37.5 kN	37.5 kN	31.5 kN	31.5 kN	29.0 kN	11.5 kN	9.5 kN	6.5 kN	3.5 kN	23.5 kN	16.5 kN
22	88 mm	40.0 kN	39.5 kN	33.0 kN	33.0 kN	30.5 kN	12.5 kN	10.0 kN	6.5 kN	4.0 kN	24.5 kN	17.5 kN
23	92 mm	42.5 kN	42.0 kN	34.5 kN	34.5 kN	32.0 kN	13.0 kN	10.5 kN	7.0 kN	4.0 kN	26.0 kN	18.5 kN
24	96 mm	44.5 kN	44.5 kN	36.0 kN	36.0 kN	33.5 kN	13.5 kN	11.0 kN	7.5 kN	4.5 kN	27.0 kN	19.5 kN
25	100 mm	46.5 kN	46.5 kN	37.5 kN	37.5 kN	35.0 kN	14.0 kN	11.5 kN	7.5 kN	4.5 kN	28.0 kN	20.5 kN
26	104 mm	47.0 kN	47.0 kN	39.5 kN	39.5 kN	36.5 kN	14.5 kN	12.0 kN	8.0 kN	5.0 kN	28.5 kN	21.5 kN
27	108 mm	47.0 kN	47.0 kN	40.0 kN	40.0 kN	37.5 kN	15.5 kN	12.5 kN	8.5 kN	5.0 kN	28.5 kN	22.0 kN
28	112 mm	47.5 kN	47.5 kN	40.5 kN	40.5 kN	37.5 kN	16.0 kN	13.0 kN	8.5 kN	5.5 kN	28.5 kN	22.0 kN
29	116 mm	47.5 kN	47.5 kN	40.5 kN	40.5 kN	37.5 kN	16.5 kN	13.5 kN	9.0 kN	5.5 kN	29.0 kN	22.5 kN
30	120 mm	48.0 kN	48.0 kN	40.5 kN	40.5 kN	38.0 kN	17.0 kN	14.0 kN	9.5 kN	6.0 kN	29.0 kN	22.5 kN
31	124 mm	48.0 kN	48.0 kN	41.0 kN	41.0 kN	38.0 kN	17.5 kN	14.5 kN	9.5 kN	6.0 kN	29.0 kN	22.5 kN
32	128 mm	48.0 kN	48.0 kN	41.0 kN	41.0 kN	38.0 kN	18.5 kN	15.0 kN	10.0 kN	6.5 kN	29.0 kN	22.5 kN
33	132 mm	48.5 kN	48.5 kN	41.0 kN	41.0 kN	38.0 kN	19.0 kN	15.5 kN	10.5 kN	6.5 kN	29.0 kN	22.5 kN
34	136 mm	48.5 kN	48.5 kN	41.5 kN	41.0 kN	38.5 kN	19.5 kN	16.0 kN	10.5 kN	7.0 kN	29.0 kN	22.5 kN
35	140 mm	48.5 kN	48.5 kN	41.5 kN	41.5 kN	38.5 kN	20.0 kN	16.5 kN	11.0 kN	7.0 kN	29.5 kN	23.0 kN
36	144 mm	49.0 kN	49.0 kN	41.5 kN	41.5 kN	38.5 kN	21.0 kN	17.0 kN	11.5 kN	7.5 kN	29.5 kN	23.0 kN
37	148 mm	49.0 kN	49.0 kN	41.5 kN	41.5 kN	38.5 kN	21.5 kN	17.5 kN	11.5 kN	7.5 kN	29.5 kN	23.0 kN
38	152 mm	49.0 kN	49.0 kN	42.0 kN	41.5 kN	38.5 kN	22.0 kN	18.0 kN	12.0 kN	8.0 kN	29.5 kN	23.0 kN
39	156 mm	49.0 kN	49.0 kN	42.0 kN	42.0 kN	39.0 kN	22.5 kN	18.0 kN	12.5 kN	8.0 kN	29.5 kN	23.0 kN
40	160 mm	49.0 kN	49.0 kN	42.0 kN	42.0 kN	39.0 kN	23.0 kN	18.5 kN	12.5 kN	8.5 kN	29.5 kN	23.0 kN

1) Check availability (chapter ZB)

Maximum permissible feed forces – description see page ZB-36





ATLANTA

Rack and Pinion Drive – Calculation and Selection – Module 5 – Straight Tooth System

Rack		UHPR		HPR		PR			BR			
Quality		4	5	6	7	8			9	10		
Rack	Material	C45	16MnCr5	C45	C45	C45	42CrMo4		C45	C45		
	Heat Treatment	Ind. Hardened	Case Hardened	Induction Hardened		Ind. Hardened	Quenched + Tempered		Soft		Induction Hardened	
Pinion	Material	16MnCr5	16MnCr5	16MnCr5	16MnCr5	16MnCr5	16MnCr5	C45	16MnCr5	C45	16MnCr5	C45
	Heat Treatment	Case Hardened	Case Hardened	Case Hardened	Case Hardened	Case Hardened	Case Hardened	Ind. Hardened	Case Hardened	Soft	Case Hardened	Ind. Hardened
No. of Pinion Teeth ¹⁾	Pitch Circle Dia.	Maximum Feed Force										
12	60 mm	19.0 kN	19.0 kN	19.0 kN	19.0 kN	18.0 kN	8.5 kN	7.0 kN	5.0 kN	2.0 kN	17.5 kN	10.0 kN
13	65 mm	23.0 kN	23.0 kN	23.0 kN	23.0 kN	21.5 kN	9.5 kN	7.5 kN	5.5 kN	2.5 kN	20.5 kN	12.0 kN
14	70 mm	29.0 kN	29.0 kN	28.5 kN	28.5 kN	26.5 kN	11.0 kN	9.0 kN	6.0 kN	2.5 kN	23.5 kN	13.5 kN
15	75 mm	31.5 kN	32.0 kN	31.5 kN	31.5 kN	29.0 kN	11.5 kN	9.5 kN	6.5 kN	3.0 kN	26.5 kN	15.5 kN
16	80 mm	35.0 kN	37.0 kN	35.0 kN	35.0 kN	32.5 kN	13.0 kN	10.5 kN	7.0 kN	3.5 kN	28.0 kN	17.0 kN
17	85 mm	39.5 kN	42.5 kN	39.5 kN	39.0 kN	36.5 kN	14.5 kN	12.0 kN	8.0 kN	4.0 kN	30.0 kN	19.0 kN
18	90 mm	42.0 kN	47.0 kN	42.0 kN	42.0 kN	39.0 kN	15.5 kN	12.5 kN	8.5 kN	4.5 kN	31.5 kN	20.5 kN
19	95 mm	44.5 kN	51.0 kN	44.5 kN	44.5 kN	41.0 kN	16.5 kN	13.5 kN	9.0 kN	5.0 kN	33.5 kN	22.5 kN
20	100 mm	47.0 kN	55.0 kN	47.0 kN	47.0 kN	43.5 kN	17.5 kN	14.0 kN	9.5 kN	5.5 kN	35.0 kN	24.0 kN
21	105 mm	49.5 kN	58.5 kN	49.5 kN	49.5 kN	45.5 kN	18.5 kN	15.0 kN	10.0 kN	6.0 kN	37.0 kN	25.5 kN
22	110 mm	52.0 kN	62.5 kN	52.0 kN	52.0 kN	48.0 kN	19.5 kN	15.5 kN	10.5 kN	6.0 kN	39.0 kN	27.0 kN
23	115 mm	54.5 kN	66.5 kN	54.5 kN	54.5 kN	50.5 kN	20.5 kN	16.5 kN	11.0 kN	6.5 kN	40.5 kN	29.0 kN
24	120 mm	57.0 kN	70.5 kN	57.0 kN	57.0 kN	52.5 kN	21.5 kN	17.0 kN	11.5 kN	7.0 kN	42.5 kN	30.5 kN
25	125 mm	59.5 kN	72.5 kN	59.5 kN	59.5 kN	55.0 kN	22.0 kN	18.0 kN	12.0 kN	7.5 kN	44.0 kN	32.0 kN
26	130 mm	61.0 kN	73.0 kN	61.0 kN	61.0 kN	56.5 kN	23.0 kN	19.0 kN	12.5 kN	8.0 kN	44.5 kN	33.5 kN
27	135 mm	61.5 kN	73.5 kN	61.0 kN	61.0 kN	56.5 kN	24.0 kN	19.5 kN	13.0 kN	8.0 kN	45.0 kN	35.0 kN
28	140 mm	61.5 kN	74.0 kN	61.5 kN	61.5 kN	57.0 kN	25.0 kN	20.5 kN	13.5 kN	8.5 kN	45.0 kN	35.0 kN
29	145 mm	62.0 kN	74.5 kN	61.5 kN	61.5 kN	57.0 kN	26.0 kN	21.0 kN	14.0 kN	9.0 kN	45.0 kN	35.0 kN
30	150 mm	62.0 kN	75.0 kN	62.0 kN	62.0 kN	57.5 kN	27.0 kN	22.0 kN	14.5 kN	9.5 kN	45.5 kN	35.5 kN

1) Check availability (chapter ZB)

Maximum permissible feed forces – description see page ZB-36



ATLANTA

Rack and Pinion Drive – Calculation and Selection – Module 6 – Straight Tooth System

Rack		UHPR	HPR		BR			
Quality		4	6	7	9	10		
Rack	Material	C45	C45	C45	C45		C45	
	Heat Treatment	Ind. Hardened	Induction Hardened		Soft		Induction Hardened	
Pinion	Material	16MnCr5	16MnCr5	16MnCr5	16MnCr5	C45	16MnCr5	C45
	Heat Treatment	Case Hardened	Case Hardened	Case Hardened	Case Hardened	Soft	Case Hardened	Ind. Hardened
No. of Pinion Teeth ¹⁾	Pitch Circle Dia.	Maximum Feed Force						
12	72 mm	27.5 kN	27.5 kN	27.5 kN	7.5 kN	3.0 kN	25.5 kN	15.0 kN
13	78 mm	33.5 kN	33.5 kN	33.5 kN	8.0 kN	3.5 kN	30.0 kN	17.5 kN
14	84 mm	41.5 kN	41.5 kN	41.5 kN	8.5 kN	4.0 kN	34.5 kN	20.0 kN
15	90 mm	46.0 kN	45.5 kN	45.5 kN	9.0 kN	4.5 kN	38.0 kN	22.5 kN
16	96 mm	50.5 kN	50.5 kN	50.5 kN	10.0 kN	5.0 kN	40.5 kN	25.0 kN
17	102 mm	56.5 kN	56.5 kN	56.5 kN	11.5 kN	6.0 kN	43.5 kN	27.5 kN
18	108 mm	61.0 kN	61.0 kN	61.0 kN	12.5 kN	7.0 kN	46.0 kN	30.0 kN
19	114 mm	64.5 kN	64.5 kN	64.5 kN	13.0 kN	7.5 kN	48.5 kN	32.5 kN
20	120 mm	68.0 kN	68.0 kN	68.0 kN	14.0 kN	8.0 kN	51.0 kN	34.5 kN
21	126 mm	71.5 kN	71.5 kN	71.5 kN	14.5 kN	8.5 kN	53.5 kN	37.0 kN
22	132 mm	75.5 kN	75.0 kN	75.0 kN	15.5 kN	9.0 kN	56.0 kN	39.5 kN
23	138 mm	79.0 kN	79.0 kN	78.5 kN	16.0 kN	9.5 kN	58.5 kN	42.0 kN
24	144 mm	82.5 kN	82.5 kN	82.5 kN	17.0 kN	10.5 kN	61.0 kN	44.0 kN
25	150 mm	86.0 kN	86.0 kN	86.0 kN	17.5 kN	11.0 kN	61.5 kN	46.5 kN
26	156 mm	87.5 kN	87.5 kN	87.5 kN	18.5 kN	11.5 kN	62.0 kN	49.0 kN
27	162 mm	88.0 kN	87.5 kN	87.5 kN	19.0 kN	12.0 kN	62.0 kN	50.0 kN
28	168 mm	88.5 kN	88.0 kN	88.0 kN	20.0 kN	12.5 kN	62.5 kN	50.0 kN
29	174 mm	88.5 kN	88.5 kN	88.5 kN	20.5 kN	13.0 kN	62.5 kN	50.5 kN
30	180 mm	89.0 kN	89.0 kN	89.0 kN	21.5 kN	13.5 kN	63.0 kN	50.5 kN

1) Check availability (chapter ZB)

Maximum permissible feed forces – description see page ZB-36





ATLANTA

Rack and Pinion Drive – Calculation and Selection – Module 8 – Straight Tooth System

Rack		UHPR	HPR			BR			
Quality		4	6	7	9	10			
Rack	Material	C45	C45	C45	C45		C45		
	Heat Treatment	Ind. Hardened	Induction Hardened			Soft		Induction Hardened	
Pinion	Material	16MnCr5	16MnCr5	16MnCr5	16MnCr5	C45	16MnCr5	C45	
	Heat Treatment	Case Hardened	Case Hardened	Case Hardened	Case Hardened	Soft	Case Hardened	Ind. Hardened	
No. of Pinion Teeth ¹⁾	Pitch Circle Dia.	Maximum Feed Force							
12	96 mm	49.5 kN	49.5 kN	49.5 kN	13.0 kN	5.5 kN	45.5 kN	26.5 kN	
13	104 mm	60.0 kN	60.0 kN	60.0 kN	14.5 kN	6.5 kN	53.5 kN	31.0 kN	
14	112 mm	74.5 kN	74.5 kN	74.5 kN	16.0 kN	7.5 kN	61.5 kN	35.5 kN	
15	120 mm	82.0 kN	82.0 kN	82.0 kN	16.5 kN	8.0 kN	68.0 kN	40.0 kN	
16	128 mm	90.5 kN	90.0 kN	90.0 kN	18.5 kN	9.5 kN	72.5 kN	44.5 kN	
17	136 mm	101.5 kN	101.5 kN	101.5 kN	21.0 kN	11.0 kN	77.5 kN	49.0 kN	
18	144 mm	109.0 kN	109.0 kN	109.0 kN	22.5 kN	12.5 kN	82.0 kN	53.5 kN	
19	152 mm	115.5 kN	115.5 kN	115.5 kN	23.5 kN	13.5 kN	86.5 kN	57.5 kN	
20	160 mm	121.5 kN	121.5 kN	121.5 kN	25.0 kN	14.5 kN	91.0 kN	62.0 kN	
21	168 mm	128.0 kN	128.0 kN	128.0 kN	26.5 kN	15.5 kN	95.5 kN	66.0 kN	
22	176 mm	134.5 kN	134.5 kN	134.5 kN	27.5 kN	16.5 kN	100.0 kN	70.5 kN	
23	184 mm	141.0 kN	141.0 kN	141.0 kN	29.0 kN	17.5 kN	104.5 kN	74.5 kN	
24	192 mm	147.5 kN	147.5 kN	147.5 kN	30.5 kN	18.5 kN	107.5 kN	79.0 kN	
25	200 mm	152.5 kN	152.5 kN	152.5 kN	31.5 kN	19.5 kN	108.0 kN	83.0 kN	
26	208 mm	153.5 kN	153.0 kN	153.0 kN	33.0 kN	20.5 kN	108.5 kN	87.0 kN	
27	216 mm	154.0 kN	154.0 kN	153.5 kN	34.5 kN	21.5 kN	109.0 kN	87.5 kN	
28	224 mm	154.5 kN	154.5 kN	154.5 kN	35.5 kN	22.5 kN	109.5 kN	88.0 kN	
29	232 mm	155.0 kN	155.0 kN	155.0 kN	37.0 kN	23.5 kN	110.0 kN	88.5 kN	
30	240 mm	156.0 kN	155.5 kN	155.5 kN	38.5 kN	24.5 kN	110.0 kN	88.5 kN	

1) Check availability (chapter ZB)

Maximum permissible feed forces – description see page ZB-36



ATLANTA

Rack and Pinion Drive – Calculation and Selection – Module 10 – Straight Tooth System

Rack		UHPR	HPR	BR			
Quality		4	6	9		10	
Rack	Material	C45	C45	C45		C45	
	Heat Treatment	Ind. Hardened	Ind. Hardened	Soft		Induction Hardened	
Pinion	Material	16MnCr5	16MnCr5	16MnCr5	C45	16MnCr5	C45
	Heat Treatment	Case Hardened	Case Hardened	Case Hardened	Soft	Case Hardened	Ind. Hardened
No. of Pinion Teeth ¹⁾	Pitch Circle Dia.	Maximum Feed Force					
12	120 mm	78.0 kN	77.5 kN	21.0 kN	8.5 kN	71.5 kN	41.5 kN
13	130 mm	94.0 kN	94.0 kN	22.5 kN	10.0 kN	84.0 kN	49.0 kN
14	140 mm	117.0 kN	117.0 kN	25.0 kN	11.5 kN	96.0 kN	56.0 kN
15	150 mm	128.5 kN	128.5 kN	26.5 kN	13.0 kN	107.0 kN	63.0 kN
16	160 mm	141.5 kN	141.5 kN	29.0 kN	15.0 kN	114.0 kN	70.0 kN
17	170 mm	159.5 kN	159.5 kN	33.0 kN	17.5 kN	121.0 kN	77.0 kN
18	180 mm	171.0 kN	171.0 kN	35.0 kN	19.5 kN	128.0 kN	83.5 kN
19	190 mm	181.0 kN	180.5 kN	37.0 kN	21.0 kN	135.5 kN	90.5 kN
20	200 mm	191.0 kN	191.0 kN	39.5 kN	22.5 kN	142.5 kN	97.0 kN
21	210 mm	201.0 kN	201.0 kN	41.5 kN	24.5 kN	149.5 kN	104.0 kN
22	220 mm	211.0 kN	211.0 kN	43.5 kN	26.0 kN	156.5 kN	110.5 kN
23	230 mm	221.0 kN	221.0 kN	45.5 kN	27.5 kN	163.5 kN	117.0 kN
24	240 mm	231.0 kN	231.0 kN	47.5 kN	29.0 kN	165.0 kN	123.5 kN
25	250 mm	234.0 kN	234.0 kN	49.5 kN	31.0 kN	166.0 kN	130.0 kN

1) Check availability (chapter ZB)

Maximum permissible feed forces – description see page ZB-36





ATLANTA

Rack and Pinion Drive – Calculation and Selection – Module 12 – Straight Tooth System

Rack		UHPR	HPR
Quality		4	6
Rack	Material	C45	C45
	Heat Treatment	Ind. Hardened	Ind. Hardened
Pinion	Material	16MnCr5	16MnCr5
	Heat Treatment	Case Hardened	Case Hardened
No. of Pinion Teeth ¹⁾	Pitch Circle Dia.	Maximum Feed Force	
12	144 mm	111.0 kN	111.0 kN
13	156 mm	134.5 kN	134.0 kN
14	168 mm	167.0 kN	167.0 kN
15	180 mm	183.5 kN	183.5 kN
16	192 mm	204.0 kN	203.5 kN
17	204 mm	225.5 kN	225.5 kN
18	216 mm	244.0 kN	243.5 kN
19	228 mm	258.0 kN	258.0 kN
20	240 mm	272.5 kN	272.0 kN
21	252 mm	286.5 kN	286.5 kN
22	264 mm	301.0 kN	300.5 kN
23	276 mm	315.5 kN	315.0 kN
24	288 mm	329.5 kN	329.5 kN
25	300 mm	333.5 kN	333.0 kN

1) Check availability (chapter ZB)

Maximum permissible feed forces – description see page ZB-36



90° Arrangement

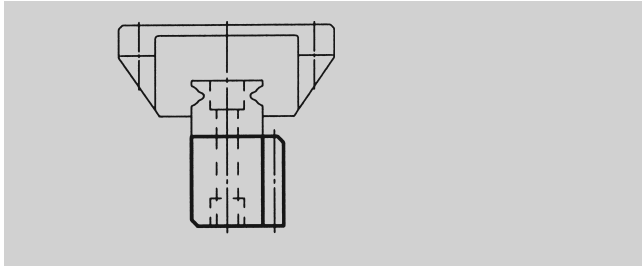

180° Arrangement

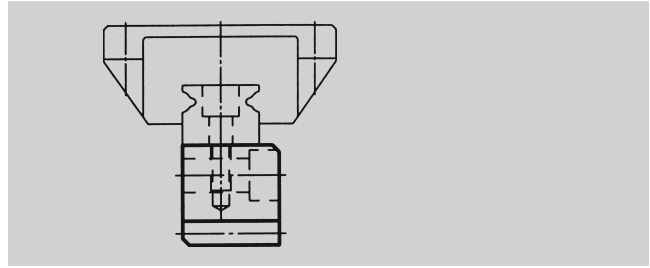

- Adjusting between rack and rail not necessary
- Space-saving and performance-optimized design can be realized
- Different types of integrated racks allows best price-performance-ratio
- Allows assembling of integrated rack and rail outside the machine
- On-site mounting of integrated rack and rail with corresponding device
- Continuous linking of the integrated rack with rails
- Additional requirement: threads in the rail for the 90° arrangement

Helical Integrated Rack





Class	Quality	Module	Total Pitch Error (µm/m)	Tooth Thickness Tolerance (µm)	Max. Length (mm)	Feed Force per Pinion Contact/ Tooth Wide (kN/width)	Applications (Examples)
HPIR High Precision Integrated Rack	6	2	34	-20	960	6.8/24	Machine Tools, Wood, Plastic Working Machines
		3	34	-20	960	12.0/29	
		4	34	-20	960	23.5/39	
BIR Basic Integrated Rack	9	2	150	-110	1920	1.8/25	Pick and Place Applications
		3	150	-110	1920	3.0/30	
		4	150	-110	1920	5.0/40	

Straight Integrated Rack

Class	Quality	Module	Total Pitch Error (µm/m)	Tooth Thickness Tolerance (µm)	Max. Length (mm)	Feed Force per Pinion Contact/ Tooth Wide (kN/width)	Applications (Examples)
HPIR High Precision Integrated Rack	6	5	34	-20	960	5/24	Machine Tools, Wood, Plastic Working Machines
		10	34	-20	960	12/29	
		13.33	34	-20	960	23/39	
BIR Basic Integrated Rack	9	5	150	-110	1920	1.5/25	Pick and Place Applications
		10	150	-110	1920	5.5/30	
		13.33	150	-110	1920	6.5/40	











	Series	Straight/ Helical	Module	Heat-Treatment of Teeth		Page
HPIR	49	Helical ¹⁾	2, 3, 4	Induction-Hardened	6 h 25	ZC-4/5
	49	Straight	5, 10, 13.33 mm	Induction-Hardened	6 h 25	ZC-8/9
BIR	49	Helical ¹⁾	2, 3, 4	Soft	9 e 27	ZC-6/7
	49	Straight	5, 10, 13.33 mm	Soft	9 e 27	ZC-10/11
	Mounting Guide for 90° Version					ZC-12
	Mounting Guide for 180° Version					ZC-13
	Selection and Load Tables					ZC-15-20
	Electronically Controlled Lubricators, Sliding-Type Lubricating Brushes and Hose-Connection Sets					ZE-2-6
	Felt Gear and Mounting Shaft					ZE-7-8
	Mounting					ZF-9

1) All our helical racks are right hand, except the companion racks, which are left hand!





	Series	Pitch	Heat-Treatment of Teeth	Tolerance of Teeth	Page
	24	5, 10, 13.33	Case-Hardened	6 e 25	ZC-14
	07	5, 10	Soft	8 e 25	ZC-14
	Selection and Load Tables				ZC-15-20
	Electronically Controlled Lubricators, Sliding-Type Lubricating Brushes and Hose-Connection Sets				ZE-2-6
	Felt Gear and Mounting Shaft				ZE-7-8
	Mounting				ZF-9

Suitable helical pinions are shown at page ZA -14 and following pages.

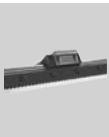



Quality 6 – 90° Version

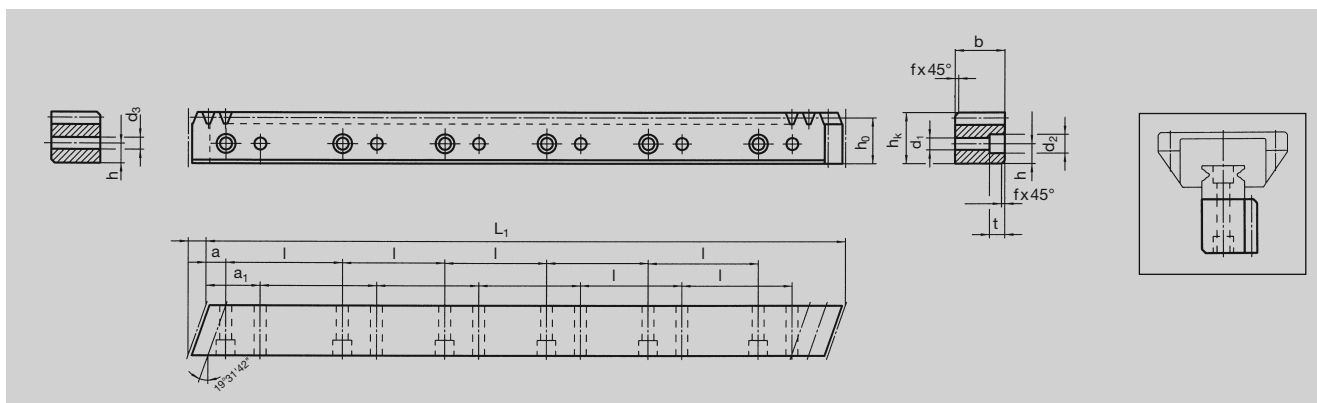

Order Code	Module	L ₁	L ₂	N° of Teeth	b	h _k	h _o	f	a	l	N° of Holes	h	d ₁	d ₂	t	a ₁	d ₃	T kg
49 29 197	2	960	6.70	144	19	19.50	17.50	1	10	60	16	7.5	4.5	7.5	5.3	30	4.5	2.7
49 29 397	2	480	6.70	72	19	19.50	17.50	1	10	60	8	7.5	4.5	7.5	5.3	30	4.5	1.3
49 29 187	2	960	8.50	144	24	24.50	22.50	1	10	60	16	10.0	6.0	9.5	8.5	30	6.0	4.2
49 29 387	2	480	8.50	72	24	24.50	22.50	1	10	60	8	10.0	6.0	9.5	8.5	30	6.0	2.1
49 39 197	3	960	10.30	96	29	29.75	26.75	2	10	60	16	11.5	7.0	11.0	9.0	30	7.0	5.6
49 39 397	3	480	10.30	48	29	29.75	26.75	2	10	60	8	11.5	7.0	11.0	9.0	30	7.0	2.8
49 49 197	4	960	13.83	72	39	39.75	35.75	2	20	80	12	14.0	10.0	15.0	9.0	40	10.0	10.5
49 49 397	4	480	13.83	36	39	39.75	35.75	2	20	80	6	14.0	10.0	15.0	9.0	40	10.0	5.2
49 49 177	4	960	13.83	72	39	48.75	44.75	2	20	80	12	17.0	10.0	15.0	9.0	40	10.0	13.0
49 49 377	4	480	13.83	36	39	48.75	44.75	2	20	80	6	17.0	10.0	15.0	9.0	40	10.0	6.5
49 49 887	4	840	17.38	63	49	58.00	54.00	2	30	105	8	22.5	14.0	20.0	13.0	60	14.0	17.3

Total pitch error: $GT_f/1000 \leq 0.034 \text{ mm}$

- Teeth induction-hardened and ground
- Material C45
- Ground on all sides after hardening

Mounting racks, see page ZF-2.

To achieve precision rack joints, we recommend our patented rack assembly kit, see page ZF-4.

For lubrication of racks & pinions, we recommend our automatic lubrication systems, see page ZE-1.

For the calculation and selection of the rack & pinion drive, see page ZD-1.



Quality 6 – 180° Version

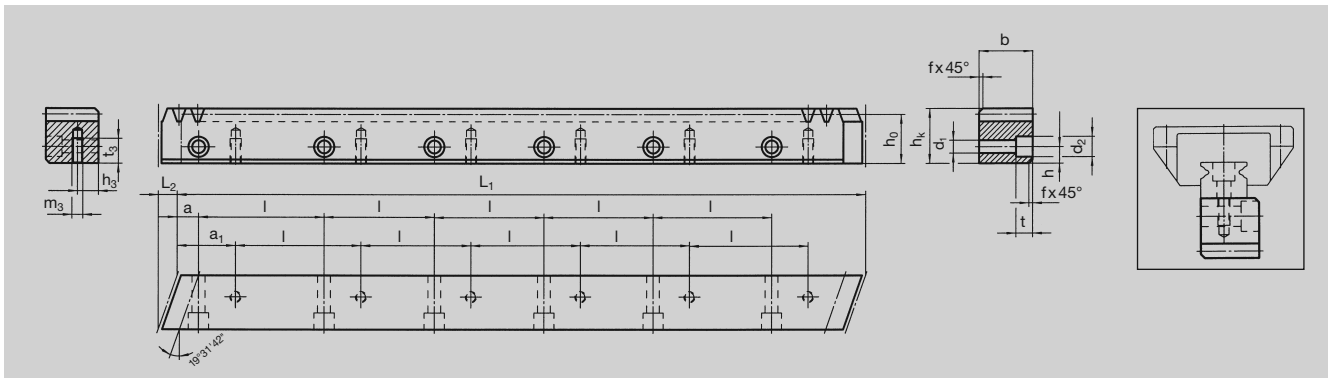

Order Code	Module	L ₁	L ₂	N° of Teeth	b	h _k	h _o	f	a	l	N° of Holes	h	d ₁	d ₂	t	a ₁	m ₃	h ₃	t ₃	kg
49 29 107	2	960	6.70	144	19	19.50	17.50	1	10	60	16	7.5	5.8	10	6	30	M4	7.5	8.0	2.7
49 29 117	2	960	8.50	144	24	24.50	22.50	1	10	60	16	10.0	7.0	11	7	30	M5	10.0	11.0	4.2
49 39 107	3	960	10.30	96	29	29.75	26.75	2	10	60	16	11.5	10.0	15	9	30	M6	11.5	13.5	5.6
49 49 107	4	960	13.83	72	39	39.75	35.75	2	20	80	12	14.0	12.0	18	12	40	M8	14.0	16.0	10.5
49 49 127	4	960	13.83	72	39	48.75	44.75	2	20	80	12	17.0	12.0	18	12	40	M8	17.0	16.0	13.0
49 49 807	4	840	17.38	63	49	58.00	54.00	2	30	105	8	22.5	14.0	20	13	60	M12	22.5	25.0	17.3

Total pitch error: $GT_f/1000 \leq 0.034$ mm

- Teeth induction-hardened and ground
- Material C45
- Ground on all sides after hardening

Mounting racks, see page ZF-2.

To achieve precision rack joints, we recommend our patented rack assembly kit, see page ZF-4.

For lubrication of racks & pinions, we recommend our automatic lubrication systems, see page ZE-1.

For the calculation and selection of the rack & pinion drive, see page ZD-1.





Quality 9 – 90° Version

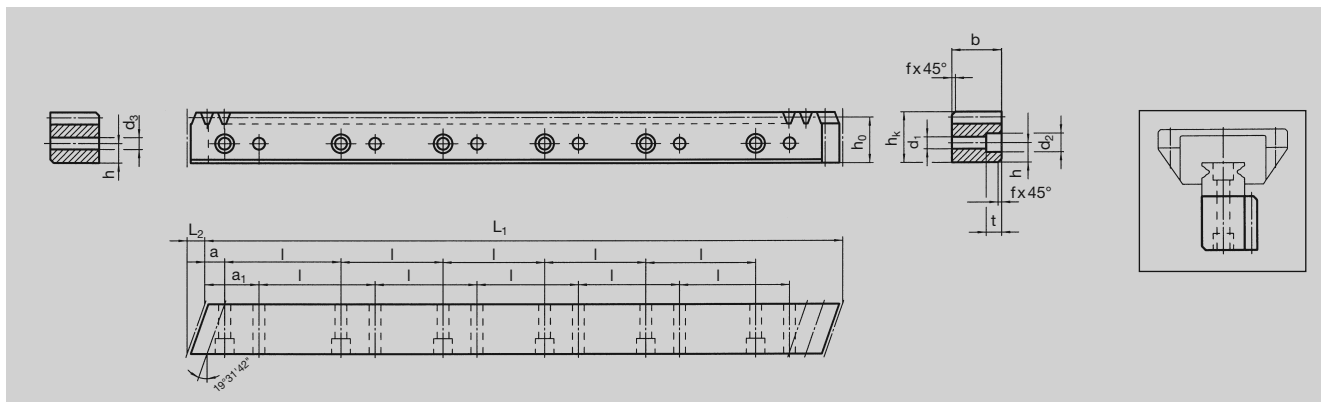

Order Code	Module	L ₁	L ₂	N° of Teeth	b	h _k	h _o	f	a	l	N° of Holes	h	d ₁	d ₂	t	a ₁	d ₃	kg
49 29 292	2	1920	7.10	288	20	19.50	17.50	1	10	60	32	7.5	4.5	7.5	5.3	30	4.5	5.4
49 29 282	2	1920	8.90	288	25	24.50	22.50	1	10	60	32	10.0	6.0	9.5	8.5	30	6.0	8.4
49 39 292	3	1920	10.60	192	30	29.75	26.75	2	10	60	32	11.5	7.0	11.0	9.0	30	7.0	11.2
49 49 292	4	1920	14.20	144	40	39.75	35.75	2	20	80	24	14.0	10.0	15.0	9.0	40	10.0	21.5
49 49 272	4	1920	14.54	144	41	48.75	44.75	2	20	80	24	17.0	10.0	15.0	9.0	40	10.0	29.9

Total pitch error $GT_f/1000 \leq 0.150$ mm.

- Milled teeth
- Material C45
- Bright steel

Mounting racks see page ZF-2.

To achieve precision rack joints, we recommend our patented rack assembly kit, see page ZF-4.

For lubrication of racks & pinions, we recommend our automatic lubrication systems, see page ZE-1.

For the calculation and selection of the rack & pinion drive, see page ZD-1.





Quality 9 – 180° Version

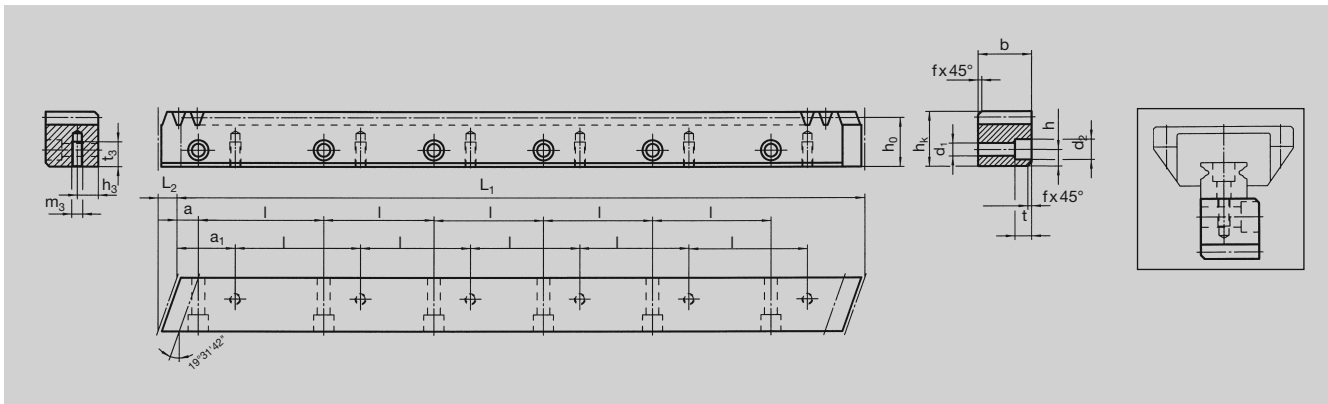

Order Code	Module	L ₁	L ₂	N° of Teeth	b	h _k	h _o	f	a	l	N° of Holes	h	d ₁	d ₂	t	a ₁	m ₃	h ₃	t ₃	kg
49 29 202	2	1920	7.1	288	20	19.50	17.50	1	10	60	32	7.5	5.8	10	6	30	M4	7.5	8.0	5.4
49 29 212	2	1920	8.9	288	25	24.50	22.50	1	10	60	32	10.0	7.0	11	7	30	M5	10.0	11.0	8.4
49 39 202	3	1920	10.6	192	30	29.75	26.75	2	10	60	32	11.5	10.0	15	9	30	M6	11.5	13.5	11.2
49 49 202	4	1920	14.2	144	40	39.75	35.75	2	20	80	24	14.0	12.0	18	12	40	M8	14.0	16.0	21.5

Total pitch error $GT_f/1000 \leq 0.150$ mm.

- Milled teeth
- Material C45
- Bright steel

Mounting racks see page ZF-2.

To achieve precision rack joints, we recommend our patented rack assembly kit, see page ZF-4.

For lubrication of racks & pinions, we recommend our automatic lubrication systems, see page ZE-1.

For the calculation and selection of the rack & pinion drive, see page ZD-1.





Quality 6 – 90° Version

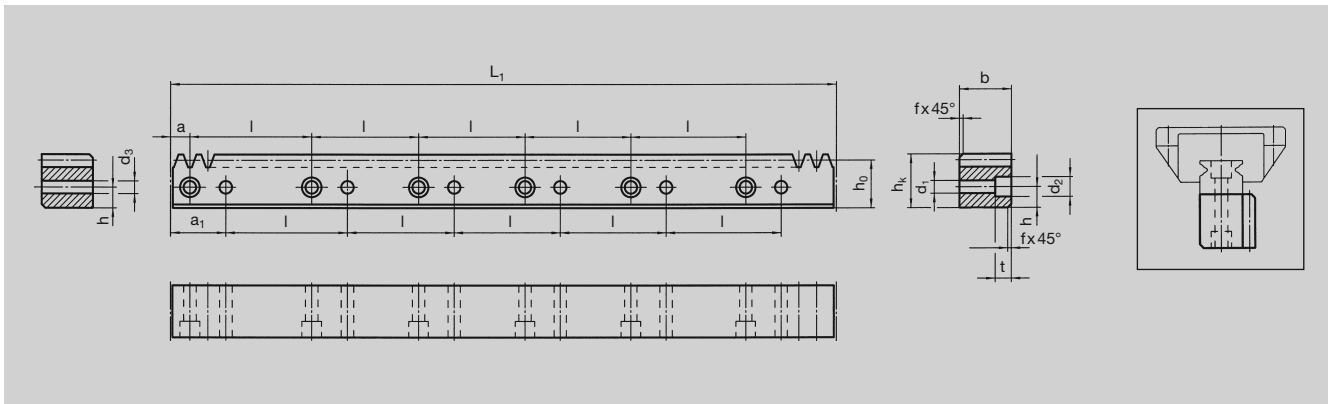

Order Code	Pitch	L ₁	N° of Teeth	b	h _k	h _o	f	a	l	N° of Holes	h	d ₁	d ₂	t	a ₁	d ₃	kg
49 77 197	5	960	192	19	19.50	17.91	1	10	60	16	7.5	4.5	7.5	5.3	30	4.5	2.7
49 77 187	5	960	192	24	24.50	22.91	1	10	60	16	10.0	6.0	9.5	8.5	30	6.0	4.2
49 97 197	10	960	96	29	29.75	26.57	2	10	60	16	11.5	7.0	11.0	9.0	30	7.0	5.6
49 47 197	13.33	960	72	39	39.75	35.50	2	20	80	12	14.0	10.0	15.0	9.0	40	10.0	10.5

Total pitch error: $GT_f/1000 \leq 0.034$ mm

- Teeth induction-hardened and ground
- Material C45
- Ground on all sides after hardening

Mounting racks see page ZF-2 and ZF-4-5.

To achieve precision rack joints, we recommend our patented rack assembly kit, see page ZF-4.

For lubrication of racks & pinions, we recommend our automatic lubrication systems, see page ZE-1.

For the calculation and selection of the rack & pinion drive, see page ZD-1.





Quality 6 – 180° Version

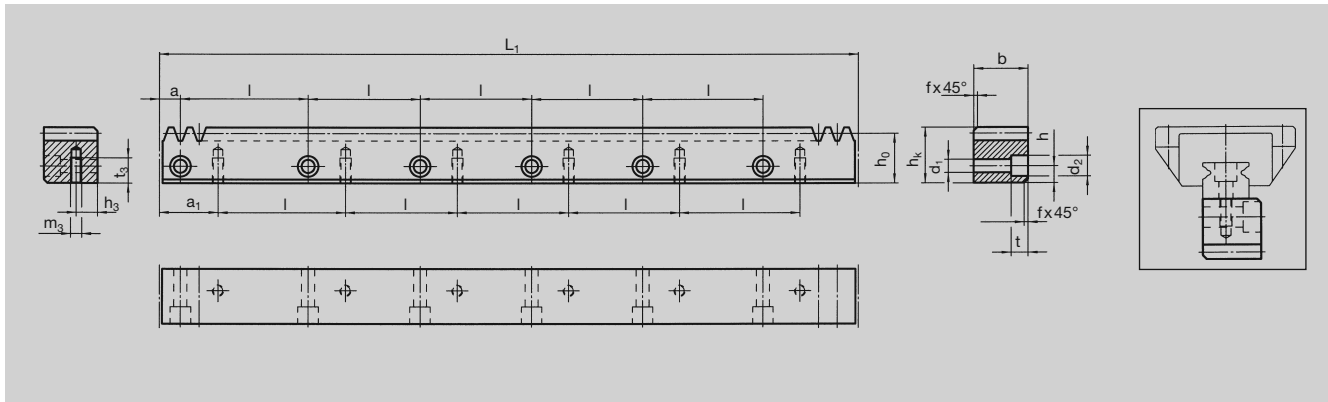

Order Code	Pitch	L ₁	N° of Teeth	b	h _k	h _o	f	a	l	N° of Holes	h	d ₁	d ₂	t	a ₁	m ₃	h ₃	t ₃	kg
49 77 107	5	960	192	19	19.50	17.91	1	10	60	16	7.5	5.8	10	6	30	M4	7.5	8.0	2.7
49 77 117	5	960	192	24	24.50	22.91	1	10	60	16	10.0	7.0	11	7	30	M5	10.0	11.0	4.2
49 97 107	10	960	96	29	29.75	26.57	2	10	60	16	11.5	10.0	15	9	30	M6	11.5	13.5	5.6
49 47 107	13.33	960	72	39	39.75	35.50	2	20	80	12	14.0	12.0	18	12	40	M8	14.0	16.0	10.5

Total Pitch Error: $GT_f/1000 \leq 0.034 \text{ mm}$

- Teeth induction-hardened and ground
- Material C45
- Ground on all sides after hardening

Mounting racks see page ZF-2 and ZF-4-5.

To achieve precision rack joints, we recommend our patented rack assembly kit, see page ZF-4.

For lubrication of racks & pinions, we recommend our automatic lubrication systems, see page ZE-1.

For the calculation and selection of the rack & pinion drive, see page ZD-1.





Quality 9 – 90° Version

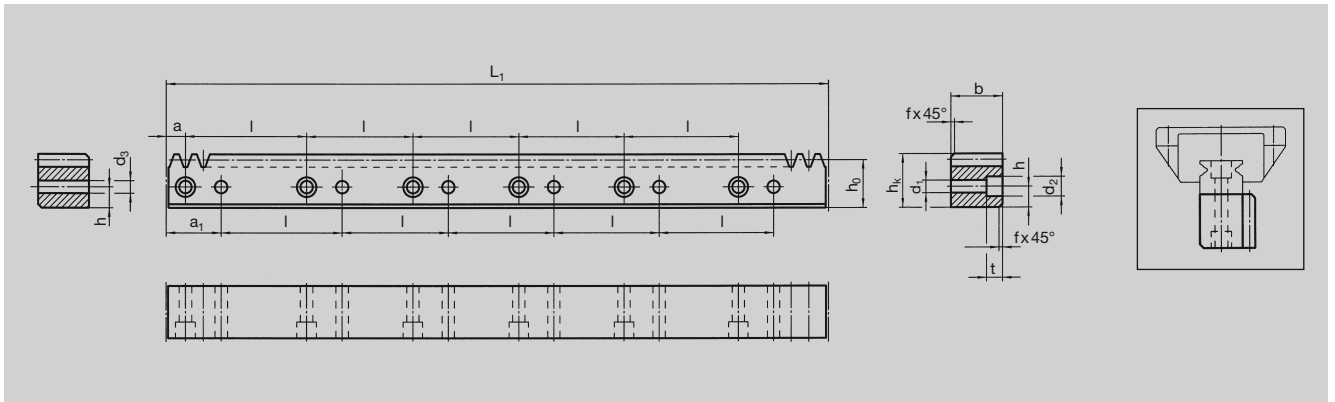

Order Code	Pitch	L ₁	N° of Teeth	b	h _k	h _o	f	a	l	N° of Holes	h	d ₁	d ₂	t	a ₁	d ₃	kg
49 77 292	5	1920	384	20	19.50	17.91	1	10	60	32	7.5	4.5	7.5	5.3	30	4.5	5.4
49 77 282	5	1920	384	25	24.50	22.91	1	10	60	32	10.0	6.0	9.5	8.5	30	6.0	8.4
49 97 292	10	1920	192	30	29.75	26.57	2	10	60	32	11.5	7.0	11.0	9.0	30	7.0	11.2
49 47 292	13.33	1920	144	40	39.75	35.50	2	20	80	24	14.0	10.0	15.0	9.0	40	10.0	21.5

Total pitch error $GT_f/1000 \leq 0.150$ mm.

- Milled teeth
- Material C45
- Bright steel

Mounting racks see page ZF-2 and ZF-4-5.

To achieve precision rack joints, we recommend our patented rack assembly kit, see page ZF-4.

For lubrication of racks & pinions, we recommend our automatic lubrication systems, see page ZE-1.

For the calculation and selection of the rack & pinion drive, see page ZD-1.



Quality 9 – 180° Version

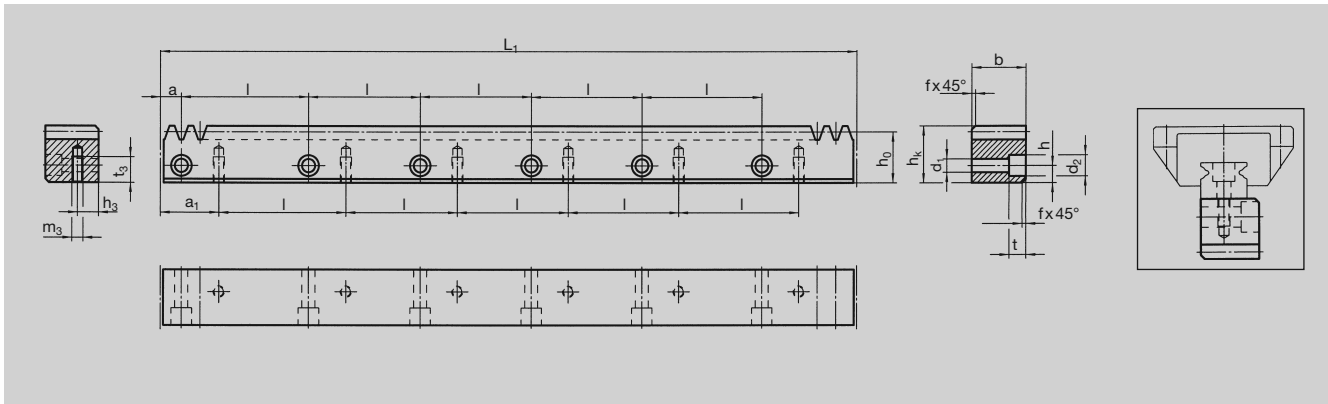

Order Code	Pitch	L ₁	N° of Teeth	b	h _k	h _o	f	a	l	N° of Holes	h	d ₁	d ₂	t	a ₁	m ₃	h ₃	t ₃	kg
49 77 202	5	1920	384	20	19.50	17.91	1	10	60	32	7.5	5.8	10	6	30	M4	7.5	8.0	5.4
49 77 212	5	1920	384	25	24.50	22.91	1	10	60	32	10.0	7.0	11	7	30	M5	10.0	11.0	8.4
49 97 202	10	1920	192	30	29.75	26.57	2	10	60	32	11.5	10.0	15	9	30	M6	11.5	13.5	11.2
49 47 202	13.33	1920	144	40	39.75	35.50	2	20	80	24	14.0	12.0	18	12	40	M8	14.0	16.0	21.5

Total Pitch error $GT_f/1000 \leq 0.150$ mm.

- Milled teeth
- Material C45
- Bright steel

Mounting racks see page ZF-2 and ZF-4-5.

To achieve precision rack joints, we recommend our patented rack assembly kit, see page ZF-4.

For lubrication of racks & pinions, we recommend our automatic lubrication systems, see page ZE-1.

For the calculation and selection of the rack & pinion drive, see page ZD-1.



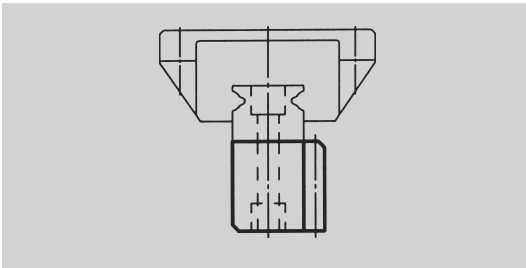

This table with the most usual rails enables (you) to select the rack suitable for the rail. The permissible feed force of the rack has to be checked, too. The rail has to be selected according to the supplier's specifications.

Racks from

90° Assembly (Additional threads required in the rail)

ATLANTA	49 29 197	49 29 187	49 39 197	49 49 197	49 49 177	49 49 887
	49 29 292	49 29 282	49 39 292	49 49 292	49 49 377	
	49 77 197	49 77 187	49 97 197	49 47 197		
	49 77 292	49 77 282	49 97 292	49 47 292		
HIWIN	LGR 15R	LGR 20R	LGR 25R	LGR 30R	LGR 35R	LGR 45R
	AGR 15U	AGR 20R	AGR 25R	AGR 30U		
	HGR 15Z	HGR 20Z	HGR 25Z	HGR 30Z	HGR 35Z	HGR 45Z
IKO		LWL 20				
	LWH 15	LWH 20	LWH 25	LWH 30	LWH 35	LWH 45
	LRX 15	LRX 20	LRX 25	LRX 30	LRX 35	LRX 45
INA		KUSE 20	KUSE 25	KUSE 30	KUSE 35	KUSE 45
	KUVE 15	KUVE 20	KUVE 25	KUVE 30	KUVE 35	KUVE 45
	KUE 15	KUE 20	KUE 25	KUE 30	KUE 35	
NSK	L1H 15	L1H 20	L1H 25	L1H 30	L1H 35	L1H 45
	L1S 15T	L1S 20	L1S 25	L1S 30	L1S 35	
	LY 15	LY 20	LY 25	LY 30	LY 35	LY 45
			LA 25	LA 30	LA 35	LA 45
Schneeberger	BM 15	BM 20	BM 25	BM 30	BM 35	BM 45
SKF	LLBHS 15	LLBHS 20	LLBHS 25	LLBHS 30	LLBHS 35	LLBHS 45
		LLBUS 20	LLBUS 25		LLBUS 35	
Star	1605-G15	1605-G20	1605-G25	1605-G30	1605-G35	1605-G45
	1646-G15	1646-G20	1646-G25	1646-G30	1646-G35	1646-G45
	1645-G15	1645-G20	1645-G25	1645-G30	1645-G35	1645-G45
THK	SSR15	SSR20	SSR25	SSR30	SSR35	
	SHS15	SHS20	SHS25	SHS30	SHS35	SHS45
	SR15	SR20	SR25	SR30	SR35	SR45
	HSR15	HSR20	HSR25	HSR30	HSR35	HSR45
	CSR15	CSR20	CSR25	CSR30	CSR35	CSR45
	GSR15	GSR20	GSR25	GSR30		
				NSR20TBC		

Mounting Device

Order Code 49 01 115 49 01 120 49 01 125 49 01 130 49 01 135 49 01 145

The device for mounting racks on rails (patented), is available upon request.



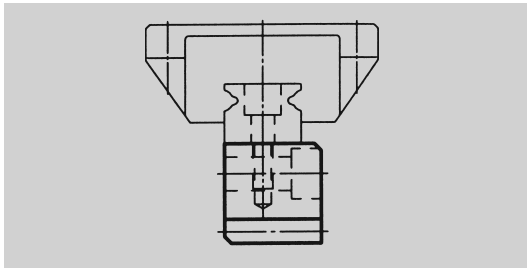

This table with the most usual rails enables (you) to select the rack suitable for the rail. the permissible feed force of the rack has to be checked, too. the rail has to be selected according to the supplier's specifications.

Racks from	180° Assembly					
ATLANTA	49 29 107	49 29 117	49 39 107	49 49 107	49 49 127	49 49 807
	49 29 202	49 29 212	49 39 202	49 49 202		
	49 77 107	49 77 117	49 97 107	49 47 107		
	49 77 202	49 77 212	49 97 202	49 47 202		
HIWIN	LGR 15R	LGR 20R	LGR 25R	LGR 30R	LGR 35R	LGR 45R
	AGR 15U	AGR 20R	AGR 25R	AGR 30U		
	HGR 15R	HGR 20R	HGR 25R	HGR 30R	HGR 35R	HGR 45R
IKO		LWL 20				
	LWH 15	LWH 20	LWH 25	LWH 30	LWH 35	LWH 45
	LRX 15	LRX 20	LRX 25	LRX 30	LRX 35	LRX 45
INA		KUSE 20	KUSE 25	KUSE 30	KUSE 35	KUSE 45
	KUVE 15	KUVE 20	KUVE 25	KUVE 30	KUVE 35	KUVE 45
	KUE 15	KUE 20	KUE 25	KUE 30	KUE 35	
NSK	L1H 15	L1H 20	L1H 25	L1H 30	L1H 35	L1H 45
	L1S 15T	L1S 20	L1S 25		L1S 35	
	LY 15	LY 20	LY 25	LY 30	LY 35	LY 45
			LA 25	LA 30	LA 35	LA 45
Schneeberger	BM 15	BM 20	BM 25	BM 30	BM 35	BM 45
SKF	LLBHS 15	LLBHS 20	LLBHS 25	LLBHS 30	LLBHS 35	LLBHS 45
		LLBUS 20	LLBUS 25		LLBUS 35	
Star	1605-G15	1605-G20	1605-G25	1605-G30	1605-G35	1605-G45
	1646-G15	1646-G20	1646-G25	1646-G30	1646-G35	1646-G45
	1645-G15	1645-G20	1645-G25	1645-G30	1645-G35	1645-G45
THK	SSR15	SSR20	SSR25		SSR35	
	SHS15	SHS20	SHS25	SHS30	SHS35	SHS45
		SR20	SR25		SR35	SR45
	HSR15	HSR20	HSR25	HSR30	HSR35	HSR45
	CSR15	CSR20	CSR25	CSR30	CSR35	CSR45
	GSR15	GSR20	GSR25	GSR30		
		RSR20				



Mounting Device

Order Code	49 01 215	49 01 220	49 01 225	49 01 230	49 01 235	49 01 245
------------	-----------	-----------	-----------	-----------	-----------	-----------

The device for mounting racks on rails (patented), is available upon request.



Straight Tooth System, Ground Teeth



16MnCr5, 1.7131

Case-Hardened

Gearing Grade
6 e 25

Order Code	Module	N° of Teeth z	d	d _k	d ₁ ^{H6}	d _N	b ₁	b ₂	u	t		Shrink-Disk on page GH-1
Pitch 5 mm												
24 06 425	1.591	25	39.79	42.9	16	30	25	51	5	18.3	0.31	80 83 030
24 00 430	1.591	30	47.75	50.9	22	36	25	54	6	24.8	0.43	80 84 036
24 03 440	1.591	40	63.66	66.8	25	44	25	56	8	28.3	0.78	80 80 044
Pitch 10 mm												
24 70 420	3.183	20	63.66	70.0	22	36	31	60	6	24.8	0.83	80 84 036
24 71 425	3.183	25	79.58	85.9	25	44	31	62	8	28.3	1.40	80 80 044
24 73 425	3.183	25	79.58	85.9	32	55	31	68	10	35.3	1.50	80 80 055
Pitch 13.33 mm												
24 93 420	4.244	20	84.89	93.3	32	55	40	77	10	35.3	2.00	80 80 055
24 95 425	4.244	25	106.10	114.6	40	62	40	77	12	43.3	2.90	80 86 062

Straight Tooth System, milled teeth

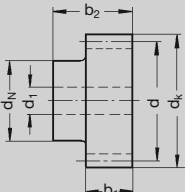

Soft

Ck45
1.0503

Gearing Grade
8 e 25

Order Code	Module m	N° of Teeth z	d	d _k	d ₁	d _N	b ₁	b ₂	
Pitch 5 mm									
07 06 012	1.591	12	19.1	22.3	6	14	12	25	0.03
07 06 015	1.591	15	23.9	27.0	6	18	12	25	0.06
07 06 018	1.591	18	28.6	31.8	8	20	12	25	0.07
07 06 020	1.591	20	31.8	35.0	8	20	12	25	0.10
07 06 025	1.591	25	39.8	43.0	8	25	12	25	0.14
07 06 030	1.591	30	47.7	50.9	10	30	12	25	0.20
07 06 040	1.591	40	63.6	66.8	10	40	12	25	0.36
07 06 050	1.591	50	79.6	82.7	12	50	12	25	0.56
07 06 060	1.591	60	95.5	98.6	12	60	12	25	0.82
Pitch 10 mm									
07 08 012	3.183	12	38.2	44.6	10	25	25	40	0.22
07 08 015	3.183	15	47.7	54.1	12	30	25	40	0.38
07 08 018	3.183	18	57.3	63.7	15	40	25	40	0.50
07 08 020	3.183	20	63.7	70.0	15	40	25	40	0.60
07 08 025	3.183	25	79.6	85.9	15	50	25	40	0.96
07 08 030	3.183	30	95.5	101.9	20	60	25	40	1.46
07 08 040	3.183	40	127.3	133.7	20	80	25	40	2.68

Further finishing (turning bores, keywaying, threading, etc.) is possible within short time.

ATLANTA
Integrated Rack and Pinion Drive – Calculation and Selection – Module 2 – Helical Tooth System

Rack		HPIR	HPIR	BIR			BIR		
Quality		6 Width 19 mm	6 Width 24 mm	9 Width 20 mm			9 Width 25 mm		
Rack	Material	16MnCr5	16MnCr5	C45			C45		
	Heat Treatment	Induction Hardened	Induction Hardened	Soft			Soft		
Pinion	Material	16MnCr5	16MnCr5	16MnCr5	C45		16MnCr5	C45	
	Heat Treatment	Case Hardened	Case Hardened	Case Hardened	Ind. Hardened		Case Hardened	Ind. Hardened	
No. of Pinion Teeth ¹⁾	Pitch Circle Dia.	Maximum Feed Force							
20	42.44	5.0 kN	6.0 kN	1.0 kN	0.8 kN		1.25 kN	1.00 kN	
25	53.05	5.4 kN	6.7 kN	1.0 kN	0.9 kN		1.25 kN	1.10 kN	
28	59.42	5.4 kN	6.7 kN	1.0 kN	1.0 kN		1.25 kN	1.25 kN	
32	67.91	5.5 kN	6.8 kN	1.5 kN	1.0 kN		1.80 kN	1.25 kN	
36	76.39	5.5 kN	6.8 kN	1.5 kN	1.0 kN		1.80 kN	1.25 kN	

1) Check availability (chapter ZA)

Maximum permissible Feed Forces ¹⁾ in kN

which are achieved with good grease lubrication (i.e. use of the electronic lubricator described on page ZE-2/3 or manual lubrication at least once a day) and $v=1.5$ m/s, $S_B=1.0$ as well as a linear load distribution factor $L_{KH\beta}$ of 1.0.

The values in the load tables are maximum values under perfect conditions and is a guide value.

A calculation of the application and configuration is in any cases needed.

Calculation and example see page ZD-1.

1) For keyway transmission make a separate calculation, torque with shrink disk see on page GH-1.





ATLANTA

Integrated Rack and Pinion Drive – Calculation and Selection – Module 3 – Helical Tooth System

Rack		HPIR		BIR					
Quality		6 Width 29 mm		9 Width 30 mm					
Rack	Material	16MnCr5		C45					
	Heat Treatment	Induction Hardened		Soft					
Pinion	Material	16MnCr5		16MnCr5	C45				
	Heat Treatment	Case Hardened		Case Hardened	Induction Hardened				
No. of Pinion Teeth ¹⁾	Pitch Circle Dia.	Maximum Feed Force							
20	63.66	12.0 kN		1.5 kN	1.5 kN				
22	70.03	12.0 kN		1.5 kN	1.5 kN				
25	79.58	12.0 kN		2.5 kN	1.5 kN				
30	95.49	12.0 kN		3.0 kN	2.0 kN				

1) Check availability (chapter ZA)

Maximum permissible feed forces – description see page ZC-15

ATLANTA
Integrated Rack and Pinion Drive – Calculation and Selection – Module 4 – Helical Tooth System

Rack		HPIR		BIR				
Quality		6 Width 39 mm		9 Width 40/41 mm				
Rack	Material	16MnCr5		C45				
	Heat Treatment	Induction Hardened		Soft				
Pinion	Material	16MnCr5		16MnCr5	C45			
	Heat Treatment	Case Hardened		Case Hardened	Induction Hardened			
No. of Pinion Teeth ¹⁾	Pitch Circle Dia.	Maximum Feed Force						
15	63.66	21.0 kN		2.5 kN	1.4 kN			
20	84.88	21.0 kN		3.5 kN	2.5 kN			
21	89.13	22.0 kN		3.5 kN	2.5 kN			
24	101.86	22.5 kN		4.5 kN	3.0 kN			
25	106.10	23.5 kN		5.0 kN	4.0 kN			

1) Check availability (chapter ZA)

Maximum permissible feed forces – description see page ZC-15





ATLANTA

Integrated Rack and Pinion Drive – Calculation and Selection – Pitch 5 – Straight Tooth System

Rack		HPIR	HPIR	BIR			BIR		
Quality		6 Width 19 mm	6 Width 24 mm	9 Width 20 mm			9 Width 25 mm		
Rack	Material	16MnCr5	16MnCr5	C45			C45		
	Heat Treatment	Induction Hardened	Induction Hardened	Soft			Soft		
Pinion	Material	16MnCr5	16MnCr5		C45			C45	
	Heat Treatment	Case Hardened	Case Hardened		Induction Hardened			Induction Hardened	
No. of Pinion Teeth ¹⁾	Pitch Circle Dia.	Maximum Feed Force							
15	23.87	0.8 kN	0.9 kN		0.25 kN			0.3 kN	
20	31.83	2.6 kN	2.9 kN		0.5 kN			0.6 kN	
25	39.79	3.5 kN	4.0 kN		0.6 kN			0.7 kN	
30	47.75	3.7 kN	4.3 kN		0.8 kN			0.9 kN	
40	63.66	4.4 kN	5.0 kN		1.0 kN			1.2 kN	

1) Check availability (chapter ZC)

Maximum permissible feed forces – description see page ZC-15

ATLANTA
Integrated Rack And Pinion Drive – Calculation And Selection – Pitch 10 – Straight Tooth System

Rack		HPIR		BIR						
Quality		6 Width 29 mm		9 Width 30 mm						
Rack		16MnCr5		C45						
	Heat Treatment	Induction Hardened		Soft						
Pinion	Material	16MnCr5		16MnCr5	C45	C45				
	Heat Treatment	Case Hardened		Case Hardened	Induction Hardened	Soft				
No. of Pinion Teeth ¹⁾	Pitch Circle Dia.	Maximum Feed Force								
15	47.75	3.6 kN		2.0 kN	1.5 kN	0.5 kN				
20	63.66	6.7 kN		2.4 kN	2.0 kN	1.4 kN				
25	79.58	11.0 kN		3.5 kN	2.5 kN	2.0 kN				
30	95.49	11.0 kN		4.0 kN	3.0 kN	2.5 kN				
40	127.32	12.0 kN		5.5 kN	4.0 kN	4.0 kN				

1) Check availability (chapter ZC)

Maximum permissible feed forces – description see page ZC-15





ATLANTA





Integrated Rack and Pinion Drive – Calculation and Selection – Pitch 13.33 – Straight Tooth System

Rack		HPIR		BIR					
Quality		6 Width 39 mm		9 Width 40 mm					
Rack	Material	16MnCr5		C45					
	Heat Treatment	Induction Hardened		Soft					
Pinion	Material	16MnCr5		16MnCr5	C45	C45			
	Heat Treatment	Case Hardened		Case Hardened	Induction Hardened	Soft			
No. of Pinion Teeth ¹⁾	Pitch Circle Dia.	Maximum Feed Force							
20	84.88	23.0 kN		5.0 kN	3.5 kN	3.0 kN			
25	106.10	23.0 kN		6.5 kN	4.5 kN	4.0 kN			

1) Check availability (chapter ZC)

Maximum permissible feed forces – description see page ZC-15



		Chapter
	Racks Helical	m = 1.5 m = 2 m = 3 m = 4 m = 5 m = 6 m = 8 m = 10 m = 12 ZA-30 ZA-31 ZA-32 ZA-33 ZA-34 ZA-35 ZA-36 ZA-37 ZA-38
	Racks Straight	m = 1 m = 1.5 m = 2 m = 2.5 m = 3 m = 4 m = 5 m = 6 m = 8 m = 10 m = 12 ZB-36 ZB-37 ZB-38 ZB-39 ZB-40 ZB-41 ZB-42 ZB-43 ZB-44 ZB-45 ZB-46
	Integrated Racks	m = 2 m = 3 m = 4 p = 5 mm p = 10 mm p = 13.33 mm ZC-15 ZC-16 ZC-17 ZC-18 ZC-19 ZC-20
	Calculation, Instruction	ZD-2
	Calculation Example	Travelling Operation Lifting Operation ZD-3 ZD-4
	Actual size of modular gearing according to DIN 867	ZD-5





The values given in the load table are based upon uniform, smooth operation, $K_{H\beta}=1.0$ and reliable grease lubrication. Since, in practice, the applications are very diverse, it is important to consider the given conditions by using appropriate factors S_B , K_A , L_{KHB} and f_n (see below).

Formulas for Determining the Tangential Force

$$a = \frac{v}{t_b} \quad [\text{m/s}^2]$$

$$F_u = \frac{m \cdot g + m \cdot a}{1000} \quad (\text{for lifting axle}) \quad [\text{kN}]$$

$$F_u = \frac{m \cdot g \cdot \mu + m \cdot a}{1000} \quad (\text{for driving axle}) \quad [\text{kN}]$$

$$F_{u \text{ perm.}} = \frac{F_{u \text{ Tab}}}{K_A \cdot S_B \cdot f_n \cdot L_{KHB}} \quad [\text{kN}]$$

Formula dimensions see page ZD-3

The Condition $F_u < F_{u \text{ perm.}}$ Must be Fulfilled.

Load Factor K_A

Drive	Type of load from the machines to be driven		
	Uniform	Medium Shocks	Heavy Shocks
Uniform	1.00	1.25	1.75
Light Shocks	1.25	1.50	2.00
Medium Shocks	1.50	1.75	2.25

Safety Coefficient S_B

The safety coefficient should be allowed for according to experience ($S_B = 1.1$ to 1.4).

Life-Time Factor f_n

considering of the peripheral speed of the pinion and lubrication.

Lubrication	Continuous	Daily	Monthly
Peripheral Speed of Gearing			
m/sec m/min			
0.5 30	0.85	0.95	
1.0 60	0.95	1.10	from
1.5 90	1.00	1.20	3
2.0 120	1.05	1.30	to
3.0 180	1.10	1.50	10
5.0 300	1.25	1.90	

Linear Load Distribution Factor L_{KHB}

The linear load distribution factor considers the contact stress, while it describes unintegrated load distribution over the tooth width ($L_{KHB} = \sqrt{K_{H\beta}}$).

$L_{KHB} = 1.1$ for counter bearing, e.g. Torque Supporter

$= 1.2$ for preloaded bearings on the output shaft e.g. ATLANTA HT, HP and E servo-worm gear unit, BG bevel-gear unit

$= 1.5$ for unpreloaded bearings on the output shaft e.g. ATLANTA B servo-worm gear unit





Calculation Example

Values Given

⊗ Travelling Operation

Mass to be Moved $m = 820$ kg

Speed $v = 2$ m/s

Acceleration Time $t_b = 1$ s

Acceleration Due to Gravity $g = 9.81$ m/s²

Coefficient of Friction $\mu = 0.1$

Load Factor $K_A = 1.5$

Life-Time Factor $f_n = 1.05$ (cont. lubrication)

Safety Coefficient $S_B = 1.2$

Linear Load Distribution Factor $L_{KH\beta} = 1.5$

Calculation Process

$$a = \frac{v}{t_b} \quad a = \frac{2}{1} = 2 \text{ m/s}^2$$

$$F_u = \frac{m \cdot g \cdot \mu + m \cdot a}{1000}$$

$$F_u = \frac{820 \cdot 9.81 \cdot 0.1 + 820 \cdot 2}{1000} = 2.44 \text{ kN}$$

Assumed feed force: rack C45, ind. hardened, straight tooth, module 3, pinion 16MnCr5, case hardened, 20 teeth, page ZB-40 with $F_{uTab} = 11.5$ kN

$$F_{u \text{ zul./per.}} = \frac{F_{uTab}}{K_A \cdot S_B \cdot f_n \cdot L_{KH\beta}} ;$$

$$F_{u \text{ zul./per.}} = \frac{11.5 \text{ kN}}{1.5 \cdot 1.2 \cdot 1.05 \cdot 1.5} = 4.05 \text{ kN}$$

Condition

$$F_{u \text{ zul./per.}} > F_u ; 4.05 \text{ kN} > 2.44 \text{ kN} \quad => \text{fulfilled}$$

Result: Rack 27 30 101 Page ZB-13

Pinion 24 35 220 Page ZB-23 case hardened

Your Calculation

Values Given

⊗ Travelling Operation

Mass to be Moved $m =$ _____ kg

Speed $v =$ _____ m/s

Acceleration Time $t_b =$ _____ s

Acceleration Due to Gravity $g =$ 9.81 m/s²

Coefficient of Friction $\mu =$ _____

Load Factor $K_A =$ _____

Life-Time Factor $f_n =$ _____

Safety Coefficient $S_B =$ _____

Linear Load Distribution Factor $L_{KH\beta} =$ _____

Calculation Process

$$a = \frac{v}{t_b} \quad a =$$
 _____ = _____ m/s²

$$F_u = \frac{m \cdot g \cdot \mu + m \cdot a}{1000} ; F_u =$$
 _____ = _____ kN

Permissible Feed Force F_{uTab}

$$F_{u \text{ zul./per.}} = \frac{F_{uTab}}{K_A \cdot S_B \cdot f_n \cdot L_{KH\beta}} ;$$

$$F_{u \text{ zul./per.}} =$$
 _____ = _____ kN

Condition

$$F_{u \text{ zul./per.}} > F_u ;$$
 _____ kN > _____ kN => fulfilled





Calculation Example

Values Given

⊗ Lifting Operation

Mass to be Moved $m = 300 \text{ kg}$

Speed $v = 1.08 \text{ m/s}$

Acceleration Time $t_b = 0.7 \text{ s}$

Acceleration Due to Gravity $g = 9.81 \text{ m/s}^2$

Load Factor $K_A = 1.2$

Life-Time Factor $f_n = 1.1$ (Cont. Lubrication)

Safety Coefficient $S_B = 1.2$

Linear Load Distribution Factor $L_{KH\beta} = 1.2$

Calculation Process

Results

$$a = \frac{v}{t_b} \quad a = \frac{1.08}{0.27} = 4 \text{ m/s}^2$$

$$F_u = \frac{m \cdot g + m \cdot a}{1000} \quad F_u = \frac{300 \cdot 9.81 + 300 \cdot 4}{1000} = 4.1 \text{ kN}$$

Assumed feed force: rack C45, ind. hardened, helical, module 2, pinion 16MnCr5, case hardened, 20 teeth, page ZA-31 with $F_{u\text{tab}} = 12 \text{ kN}$

$$F_{u\text{zul./per.}} = \frac{F_{u\text{Tab}}}{K_A \cdot S_B \cdot f_n \cdot L_{KH\beta}} ; F_{u\text{zul./per.}} = \frac{11.5 \text{ kN}}{1.2 \cdot 1.2 \cdot 1.1 \cdot 1.2} = 5.9 \text{ kN}$$

Condition

$$F_{u\text{zul./per.}} > F_u ; 6.0 \text{ kN} > 4.1 \text{ kN} \Rightarrow \text{fulfilled}$$

Result: Rack 29 20 105 Page ZA-7

Pinion 24 29 520 Page ZA-24

Your Calculation

Values Given

⊗ Lifting Operation

Mass to be Moved $m = \underline{\hspace{2cm}} \text{ kg}$

Speed $v = \underline{\hspace{2cm}} \text{ m/s}$

Acceleration Time $t_b = \underline{\hspace{2cm}} \text{ s}$

Acceleration Due to Gravity $g = \underline{9.81} \text{ m/s}^2$

Load Factor $K_A = \underline{\hspace{2cm}}$

Life-Time Factor $f_n = \underline{\hspace{2cm}}$

Safety Coefficient $S_B = \underline{\hspace{2cm}}$

Linear Load Distribution Factor $L_{KH\beta} = \underline{\hspace{2cm}}$

Calculation Process

Results

$$a = \frac{v}{t_b} \quad a = \underline{\hspace{2cm}} = \underline{\hspace{2cm}} \text{ m/s}^2$$

$$F_u = \frac{m \cdot g + m \cdot a}{1000} \quad F_{u\text{erf./req.}} = \underline{\hspace{2cm}} = \underline{\hspace{2cm}} \text{ kN}$$

Permissible Feed Force $F_{u\text{tab}}$

$$F_{u\text{zul./per.}} = \frac{F_{u\text{Tab}}}{K_A \cdot S_B \cdot f_n \cdot L_{KH\beta}} ; F_{u\text{zul./per.}} = \underline{\hspace{2cm}} = \underline{\hspace{2cm}} \text{ kN}$$

Condition

$$F_{u\text{zul./per.}} > F_u ; \underline{\hspace{2cm}} \text{ kN} > \underline{\hspace{2cm}} \text{ kN} \Rightarrow \text{fulfilled}$$





Module 1.0



Module 1.25



Module 1.5



Module 2.0



Module 2.5



Module 3.0



Module 4.0



Module 5.0



Module 6.0



Module 8.0



Module 10.0



Module 12.0





	Page
 Lubricator 125 cm ³	ZE-2
Lubricator 475 cm ³	ZE-3
Selection of the Lubrication for Rack Drives	ZE-4
Lubrication System	ZE-5-6
Felt Gear	ZE-7-8
Lubrication Equipment, Accessories	ZE-9
Lubricating Systems and Accessories	ZE-10





Electrically Controlled Lubricators – 125 cm³

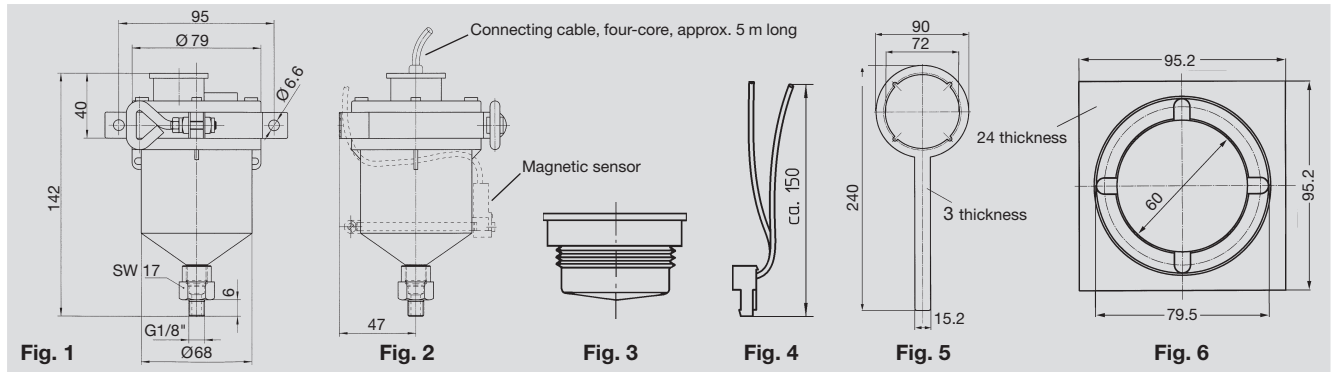

Order Code	Fig.	Klüber Microlube GB 0	Klüber Structovis AHD	Without grease	Pipe clamp	Reducer G1/4" to G1/8"	Synchronisation	Detection of end position	2 batteries 1.5 V	External power supply	Atex	Nitrogen pressure chamber	Contact cable 65 91 003 / Fig.4	Connecting cable, four-core	Magnetic sensor	Assembly wrench 65 91 030 / Fig.5	Mounting plate 65 91 031 / Fig.6	kg
65 91 000	1	●			●	●	○		●			○	○			✘	✘	0.50
65 91 004 ¹⁾	1		●		●	●	○		●			○	○			✘	✘	0.50
65 91 006	1	●			●	●					●	○				✘	✘	0.40
65 91 009	1			●	●	●	○		●			○	○			✘	✘	0.50
65 91 050	2	●			●	●	●	●	●			○	●		●	✘	✘	0.60
65 91 053 ¹⁾	2		●		●	●	○	●	●			○	○		●	✘	✘	0.60
65 91 054 ¹⁾	2		●		●	●	●	●	●			○	●		●	✘	✘	0.60
65 91 059	2			●	●	●	●	●	●			○	●		●	✘	✘	0.40
65 91 061	2	●			●	●	●	●		●		○		●	●	✘	✘	0.60
65 91 001	3								●									0.08

● Equipment of the lubricator ○ Upgrading option ⊙ Spare parts ✘ Assembly tool

¹⁾ When using Structovis AHD, we recommend to position the lubricator lower than the lubrication point or to use the check valve 65 91 025.

The function is based upon the grease gun principle. After starting the operation, a nitrogen gas is generated electrically which by means of a highly functional construction moves a piston causing the grease filling of 125 cm³ resp. 475 cm³ to emerge uni-formly (not pulsatingly) at a constant pressure set to the desired dosage. Depending on the individual requirements, an emptying time of 1-2-3-6-12 or 18 months can be set by means of a micro-switch. It is possible to adjust the grease quantity even after starting the operation by changing the micro-switch position accordingly. Detailed mounting and operating instructions come with every shipment.

The transparent housing, which can be mounted in any position, permits the visual inspection of the available grease filling at any time. When completely empty, it can be refilled and used again. Only the nitrogen chamber (Fig. 3 – 125 cm³, Fig. 9 – 475 cm³) and the batteries need to be replaced. A permanent signal lamp powered by 2 (125 cm³) resp. 4 (475 cm³) standard 1.5 V batteries confirms the activation of the lubricator. The contact cable - connected to a potential-free limit switch or contactor (no external power supply required) - permits synchronization with the machine operating time. When using the lubricator 65 91 061 (125 cm³) resp. 65 91 057 (475 cm³), the connecting cable additionally permits external power supply with 3 V DC. By powering a magnetic sensor (Fig. 2 – 125 cm³, Fig. 8 – 475 cm³) with max. 200 mA at 30 V DC the end position (empty condition) indication is transmitted to a yellow LED directly at the sensor or externally to a signal indicator or to your control unit.

- When replenishing the lubricator, consider the following:
- replace the nitrogen chamber 65 91 001 together with the batteries
 - fill up with lubricant 65 90 002 Microlube GB 0 or 65 90 003 Structovis AHD
 - for closing and opening the lubricator, use the assembly tools 65 91 030 and 65 91 031.



Electrically Controlled Lubricators – 475 cm³

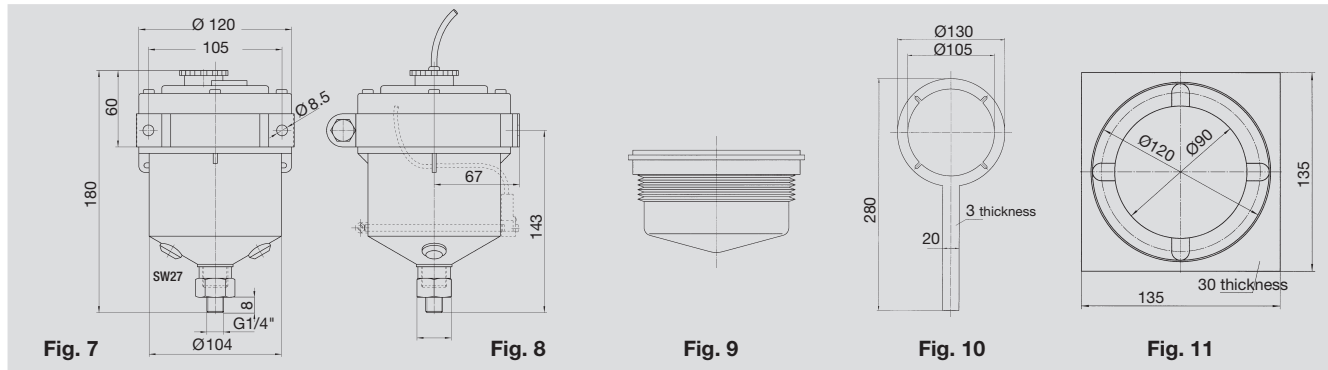

Order Code	Fig.	Klüber Microtube GB 0	Klüber Structovis AHD	Without grease	Pipe clamp	Reducer G1/2" to G1/4"	Synchronisation	Detection of end position	4 batteries 1.5 V	External power supply	Alex	Nitrogen pressure chamber / fig. 9	Connecting cable, four-core	Magnetic sensor	Assembly wrench 65 91 032 / Fig. 10	Mounting plate 65 91 033 / Fig. 11	kg
65 91 007	7	●			●	●			●			○			✱	✱	0.9
65 91 014 ¹⁾	7		●		●	●			●			○			✱	✱	0.9
65 91 069	7			●	●	●			●			○			✱	✱	0.5
65 91 067	8	●			●	●	●		●			○	●		✱	✱	1.0
65 91 056	8	●			●	●	●	●	●			○	●	●	✱	✱	1.1
65 91 057	8	●			●	●	●	●		●		○	●	●	✱	✱	1.1
65 91 068	8		●		●	●	●	●		●		○	●	●	✱	✱	0.6
65 91 058	8			●	●	●	●	●		●		○	●	●	✱	✱	1.1

● Equipment of the lubricator ○ Upgrading option ◉ Spare parts ✱ Assembly tool

¹⁾ When using Structovis AHD, we recommend to position the lubricator lower than the lubrication point or to use the check valve 65 91 025.

The function is based upon the grease gun principle. After starting the operation, a nitrogen gas is generated electrically which by means of a highly functional construction moves a piston causing the grease filling of 125 cm³ resp. 475 cm³ to emerge uni-formly (not pulsatingly) at a constant pressure set to the desired dosage. Depending on the individual requirements, an emptying time of 1-2-3-6-12 or 18 months can be set by means of a micro-switch. It is possible to adjust the grease quantity even after starting the operation by changing the micro-switch position accordingly. Detailed mounting and operating instructions come with every shipment.

The transparent housing, which can be mounted in any position, permits the visual inspection of the available grease filling at any time. When completely empty, it can be refilled and used again. Only the nitrogen chamber (Fig. 3 – 125 cm³, Fig. 9 – 475 cm³) and the batteries need to be replaced. A permanent signal lamp powered by 2 (125 cm³) resp. 4 (475 cm³) standard 1.5 V batteries confirms the activation of the lubricator. The contact cable - connected to a potential-free limit switch or contactor (no external power supply required) - permits synchronization with the machine operating time. When using the lubricator 65 91 061 (125 cm³) resp. 65 91 057 (475 cm³), the connecting cable additionally permits external power supply with 3 V DC. By powering a magnetic sensor (Fig. 2 – 125 cm³, Fig. 8 – 475 cm³) with max. 200 mA at 30 V DC the end position (empty condition) indication is transmitted to a yellow LED directly at the sensor or externally to a signal indicator or to your control unit.

- When replenishing the lubricator, consider the following:
- replace the nitrogen chamber 65 91 001 together with the batteries
 - fill up with lubricant 65 90 002 Microtube GB 0 or 65 90 003 Structovis AHD
 - for closing and opening the lubricator, use the assembly tools 65 91 030 and 65 91 031.





Lubrication of Rack and Pinion Drives

When lubricating rack and pinion drives by means of a felt gearwheel and electrically controlled lubricator the optimal grease supply can be seen from the diagram below.

For lubrication with sliding brush use the next higher switch position. If, for example, micro-switch position 4 is chosen for felt-

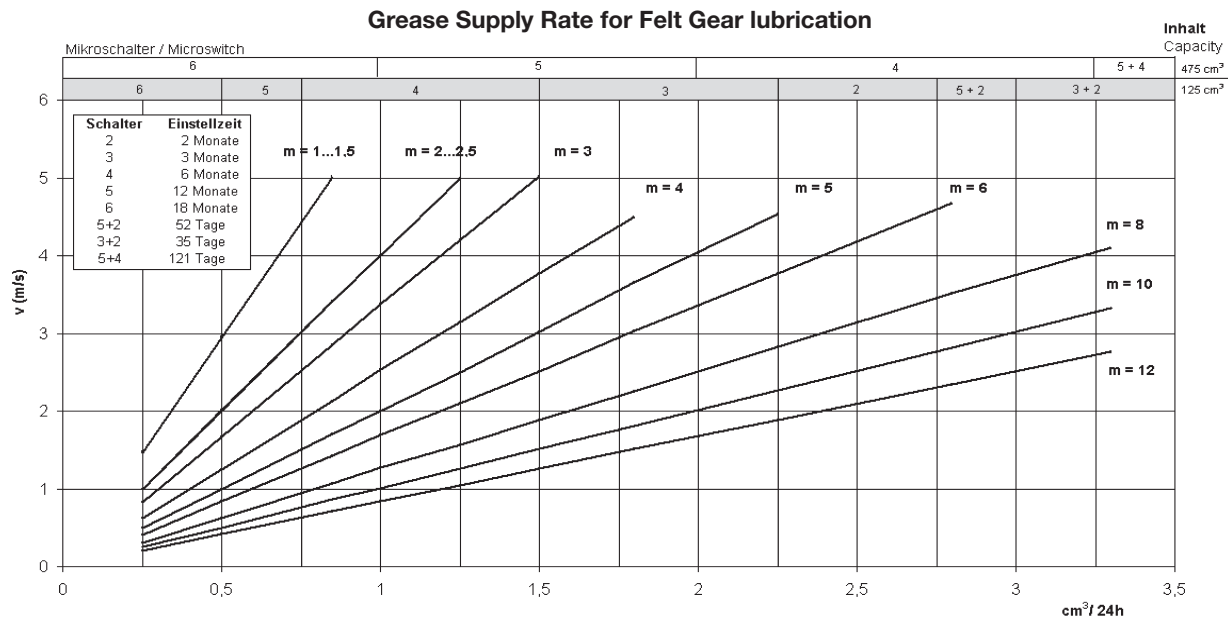

Gearwheel lubrication, choose 3 for sliding-brush lubrication at the same speed and with the same module.

Pressure Build-Up

Set all micro-switches to "ON". Pressure build-up time 6–8 hours. Then set the desired time. The micro-switch 7 must be always on. Before starting up the lubricator the connecting hose between felt wheel and lubricator should be filled and the felt wheel soaked with grease.

Battery Changing

The guaranteed service life of the battery is 1 year. Then the battery should be replaced. Although the control lamp may still flash it is possible that the battery capacity has already decreased. The lubricator can also be operated by means of external power supply via an intermediate relay.

Recommended Lubricants for Rack Drives:

Felt Gear Lubrication: Klüber Microlube GB 0
Order Code 65 90 002 (1 kg)
 Klüber Structovis AHD
Order Code 65 90 003 (1 kg)

Sliding Brush Lubrication: Klüber Microlube GB 0
Order Code 65 90 002 (1 kg)

Furthermore the following lubricants have been tested with good results.

- Oest Langzeitfett LT 200
- BP Energ grease LS EP 00
- DEA Glissando 6833 EP 00
- Fuchs Lubritech Gearmaster ZSA
- Molykote G-Rapid plus 3694





Lubricator Assemblies for HT High-Torque Gear Units with Pinion Shaft with Clamp Connection

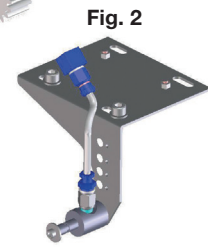
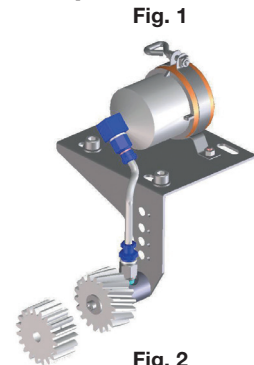
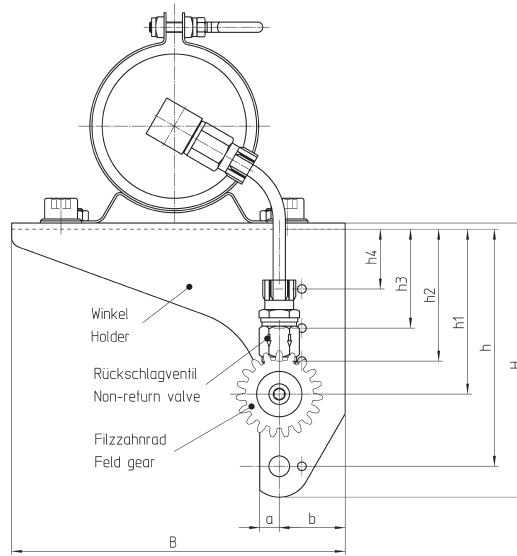
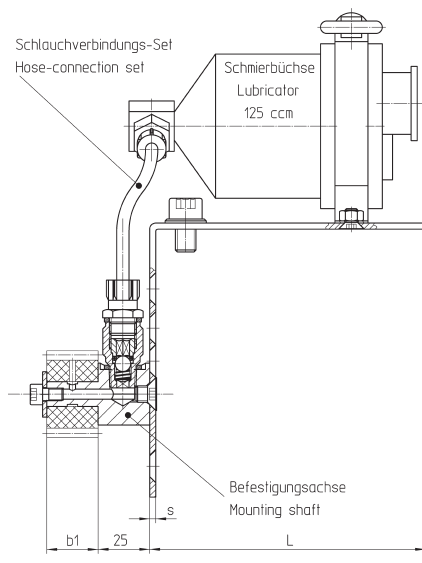

For fig. 2, lubricators can be found on page ZE-2 and felt gears on page ZE-7

Order Code	Fig. 1	Fig. 2	Tooth System	m	z	I - Straight / - Helical	h	h ₁	h ₂	h ₃	h ₄	b ₁	b ₂	s	b	H	B	L	kg
a₀ = 50																			
65 83 192	65 93 012		2	32	LU,RU	95	96	49	33	17		25	37	3	30	113	140	104	1.40
65 83 182	65 93 012	/	2	30	LU,RU	95	96	49	33	17		25	37	3	30	113	140	104	1.40
65 83 193	65 93 013		3	21	RS	95	96	49	33	17		30	36	3	30	113	140	104	1.44
65 83 183	65 93 013	/	3	20	RS	95	96	49	33	17		30	36	3	30	113	140	104	1.44
65 83 194	65 93 014		4	17	LU,RU	95	96	49	33	17		40	32	3	30	113	140	104	1.54
65 83 184	65 93 014	/	4	15	LU,RU	95	96	49	33	17		40	32	3	30	113	140	104	1.54
a₀ = 63																			
65 84 192	65 94 012		2	32	LU,RU	115	80	64	48	29		25	37	3	41	133	162	134	2.00
65 84 182	65 94 012	/	2	30	LU,RU	115	80	64	48	29		25	37	3	41	133	162	134	2.00
65 84 193	65 94 013		3	21	LU,RU	115	80	64	48	29		30	36	3	41	133	162	134	1.90
65 84 183	65 94 013	/	3	20	LU,RU	115	80	64	48	29		30	36	3	41	133	162	134	1.90
65 84 194	65 94 014		4	17	LU,RU,RS	115	80	64	48	29		40	32	3	41	133	162	134	2.00
65 84 184	65 94 014	/	4	15	LU,RU,RS	115	80	64	48	29		40	32	3	41	133	162	134	2.00
a₀ = 80																			
65 85 194	65 95 014		4	17,30*	LU,RU	130	103	85	57	36		40	32	3	51	148	198	159	2.50
65 85 184	65 95 014	/	4	15,30*	LU,RU	130	103	85	57	36		40	32	3	51	148	198	159	2.50
65 85 185	65 95 015		5	13	LU,RU	130	103	85	57	36		50	35	3	51	148	198	159	2.70
65 85 175	65 95 015	/	5	12	LU,RU	130	103	85	57	36		50	35	3	51	148	198	159	2.70
65 85 186	65 95 016		6	-	LU,RU	130	103	85	57	36		60	37	3	51	148	198	159	2.80
65 85 176	65 95 016	/	6	13	LU,RU	130	103	85	57	36		60	37	3	51	148	198	159	2.80
a₀ = 100																			
65 86 185	65 96 015 ¹⁾		5	15	LU,RU	140	102	84	52	32		50	35	4	54	169	230	182	3.30
65 86 175	65 96 015 ¹⁾	/	5	15	LU,RU	140	102	84	52	32		50	35	4	54	169	230	182	3.30
65 86 186	65 96 016 ¹⁾		6	13	LU,RU	140	102	84	52	32		60	37	4	54	169	230	182	3.50
65 86 176	65 96 016 ¹⁾	/	6	13,15*	LU,RU,LU*,RU*	140	102	84	52	32		60	37	4	54	169	230	182	3.50
65 86 188	65 96 018 ¹⁾		8	-	LU,RU	140	102	84	52	32		80	38	4	54	169	230	182	4.30
65 86 178	65 96 018 ¹⁾	/	8	12	LU,RU	140	102	84	52	32		80	38	4	54	169	230	182	4.30

Unit Mounting Possibilities

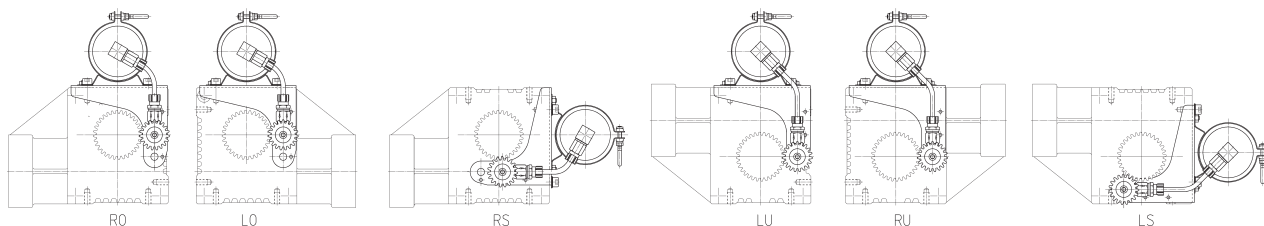

Ordering Example: a = 80, m = 4 helical tooth system, Fig. LO ⇒ **65 85 184** (Felt gear assembled according to the dimension "h2 = 85" of the mounting surface).



Lubricator Assemblies for HP/E/B/ Gear Units

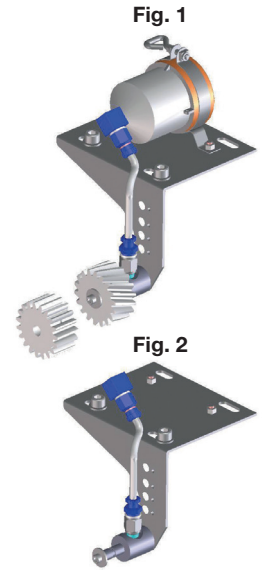
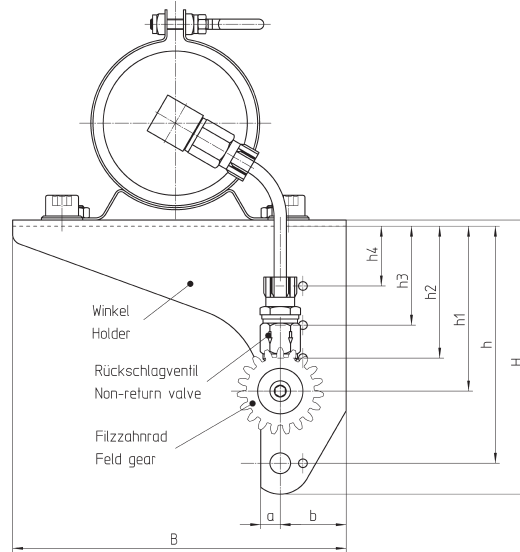
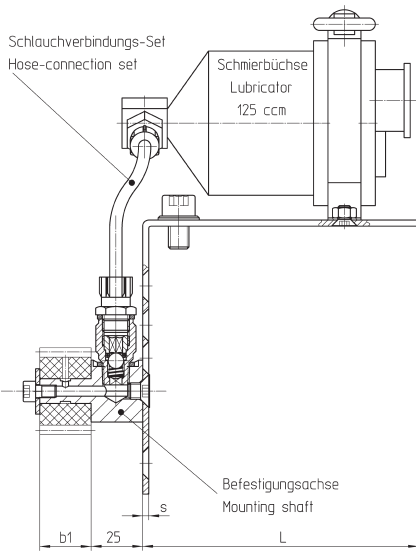

For fig. 2, lubricators can be found on page ZE-2 and felt gears on page ZE-7

Order Code	Fig. 1	Fig. 2	Tooth System	m	z	I - Straight / - Helical	h	h ₁	h ₂	h ₃	h ₄	b ₁	b ₂	s	b	H	B	L	kg
a₀ = 50																			
65 93 190	65 93 002		2	21		95	65	LU, RU	RO, LO, RS	LS	17	25	25	3	30	113	134	104	1.42
65 93 180	65 93 002	/	2	20				LU, RU	RO, LO, RS	LS		25							1.42
65 93 192	65 93 002		2	32	LU, RU, LS		95	RO, LO, RS				25							1.40
65 93 182	65 93 002	/	2	30	LU, RU, LS			RO, LO, RS				25							1.40
65 93 193	65 93 003		3	21	RS		65	LU, RU	RO, LO, LS			30							1.44
65 93 183	65 93 003	/	3	20	RS			LU, RU	RO, LO, LS			30							1.44
a₀ = 63																			
65 94 192	65 94 002		2	32	LU, RU	115	80	RO, LO, LS	LS		29	25	25	3	41	133	162	134	1.72
65 94 182	65 94 002	/	2	30	LU, RU			RO, LO, LS	LS			25							1.72
65 94 193	65 94 003		3	21	RS		63	LU, RU		RO, LO, LS		30							1.79
65 94 183	65 94 003	/	3	20	RS			LU, RU		RO, LO, LS		30							1.79
65 94 194	65 94 004		4	17				LU, RU	RS	RO, LO, LS		40							1.90
65 94 184	65 94 004	/	4	15				LU, RU	RS	RO, LO, LS		40							1.90
a₀ = 80																			
65 95 192	65 95 002		2	32	LU, RU	130	103		85	57	36	25	25	3	51	148	198	159	2.40
65 95 182	65 95 002	/	2	30	LU, RU				RO, LO, RS, LS			25							2.40
65 95 193	65 95 003		3	21	LU, RU				RO, LO, RS, LS			30							2.39
65 95 183	65 95 003	/	3	20	LU, RU				RO, LO, RS, LS			30							2.39
65 95 194	65 95 004		4	17				LU, RU	RS	RO, LO, RS		40							2.50
65 95 184	65 95 004	/	4	15				LU, RU	RS	RO, LO, RS		40							2.50
a₀ = 100																			
65 96 194	65 96 004 ¹⁾		4	17, 30*	LU, RU, RS	140	102	RO, LO, LS, LU*, RU*		RO*, LO*, LS*		40							2.60
65 96 184	65 96 004 ¹⁾	/	4	15, 30*	LU, RU, RS			RO, LO, LS, LU*, RU*		RO*, LO*, LS*		40							2.60
65 96 185	65 96 005 ¹⁾		5	13	LU, RU			RS	RO, LO, LS			50							3.30
65 96 175	65 96 005 ¹⁾	/	5	12	LU, RU			RS	RO, LO, LS			50							3.30
65 96 186	65 96 006 ¹⁾		6	-								60							3.50
65 96 176	65 96 006 ¹⁾	/	6	13				LU, RU, RS	LS	RO, LO		60							3.50
a₀ = 125																			
65 97 185	65 97 005 ¹⁾		5	15	LU, RU	198	171		128	102	-	50	25	4	78	227	290	225	3.73
65 97 175	65 97 005 ¹⁾	/	5	15	LU, RU				RO, LO, RS, LS			50							3.73
65 97 186	65 97 006 ¹⁾		6	13	RS			LU, RU	RO, LO	LS		60							3.88
65 97 176	65 97 006 ¹⁾	/	6	13, 15*	RS			LU, RU, LU*, RU*	RO, LO	LS, RO*, LO*, LS*, RS*		60							3.88
65 97 188	65 97 008 ¹⁾		8	-								80							4.50
65 97 178	65 97 008 ¹⁾	/	8	12				LU, RU			RO, LO, LS, RS	80							4.50

Unit Mounting Possibilities – see page ZE-5

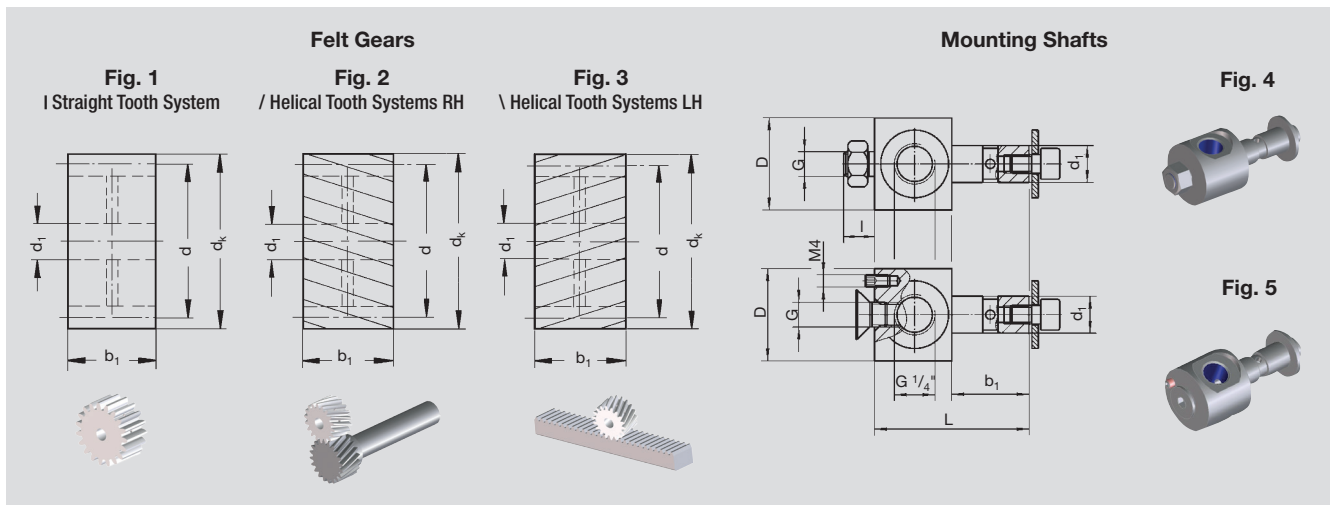

Order Code	Fig.	Module	Pitch	Flank Direction	No. of Teeth	d	dk	d1	b1	D	L	I	G	
65 91 140	1	1			40	40.0	42.0	12	15					7.5
65 91 100	4	1						12	15	30	40	10	M8	135.0
65 91 126	1	1.5			26	39.0	42.0	12	15					7.2
65 91 116	2	1.5		/	24	38.2	42.0	12	15					7.0
65 91 106	3	1.5		\	24	38.2	42.0	12	15					7.0
65 91 100	4	1.5						12	15	30	40	10	M8	135.0
65 91 024	1	1.591	5		24	38.2	41.4	12	15					6.8
65 91 100	4	1.591	5					12	15	30	40	10	M8	135.0
65 91 228	1	2			19	38.0	42.0	12	25					11.0
65 91 229	2	2		/	18	38.2	42.0	12	25					11.0
65 91 218	3	2		\	18	38.2	42.0	12	25					11.0
65 91 236	1	2			36	72.0	76.0	12	25					22.0
65 91 234	2	2		/	34	72.2	76.2	12	25					22.0
65 91 200	4	2						12	25	30	50	10	M8	143.0
65 91 210*	5	2						12	25	30	50		M8	140.0
65 91 220**	5	2						12	25	30	62		M8	150.0
65 91 222	1	2.5			22	55.0	60.0	12	25					25.0
65 91 200	4	2.5						12	25	30	50	10	M8	143.0
65 91 210	5	2.5						12	25	30	50		M8	140.0
65 91 220	5	2						12	25	30	62		M8	150.0
65 91 328	1	3			19	57.0	63.0	12	30					37.0
65 91 329	2	3		/	18	57.3	63.0	12	30					36.0
65 91 318	3	3		\	18	57.3	63.0	12	30					36.0
65 91 300	4	3						12	30	30	55	10	M8	147.0
65 91 310*	5	3						12	30	30	55		M8	145.0
65 91 320**	5	3						12	30	30	66		M8	155.0
65 91 018	1	3.183	10		18	57.3	63.6	12	30					36.0
65 91 300	4	3.183	10					12	30	30	55	10	M8	147.0
65 91 310	5	3.183	10					12	30	30	55		M8	145.0
65 91 320	5	3						12	30	30	66		M8	155.0
65 91 428	1	4			19	76.0	84.0	12	40					98.0
65 91 429	2	4		/	18	76.5	84.0	12	40					97.0
65 91 418	3	4		\	18	76.5	84.0	12	40					97.0
65 91 400	4	4						12	40	30	65	10	M8	154.0
65 91 410*	5	4						12	40	30	65		M8	150.0
65 91 420**	5	4						12	40	30	72		M8	160.0
65 91 517	3	5		\	17	90.2	100.0	20	50					133.0
65 91 518	1	5			18	90.0	100.0	20	50					133.0
65 91 529	2	5		/	17	90.2	100.0	20	50					133.0
65 91 500	4	5						20	50	50	75	15	M12	520.0
65 91 510	5	5						20	50	40	75		M8	510.0
65 91 520	5	5						20	50	40	85		M8	520.0

* For use with HP/E/B Gear Units

** For use with HT Gear Units



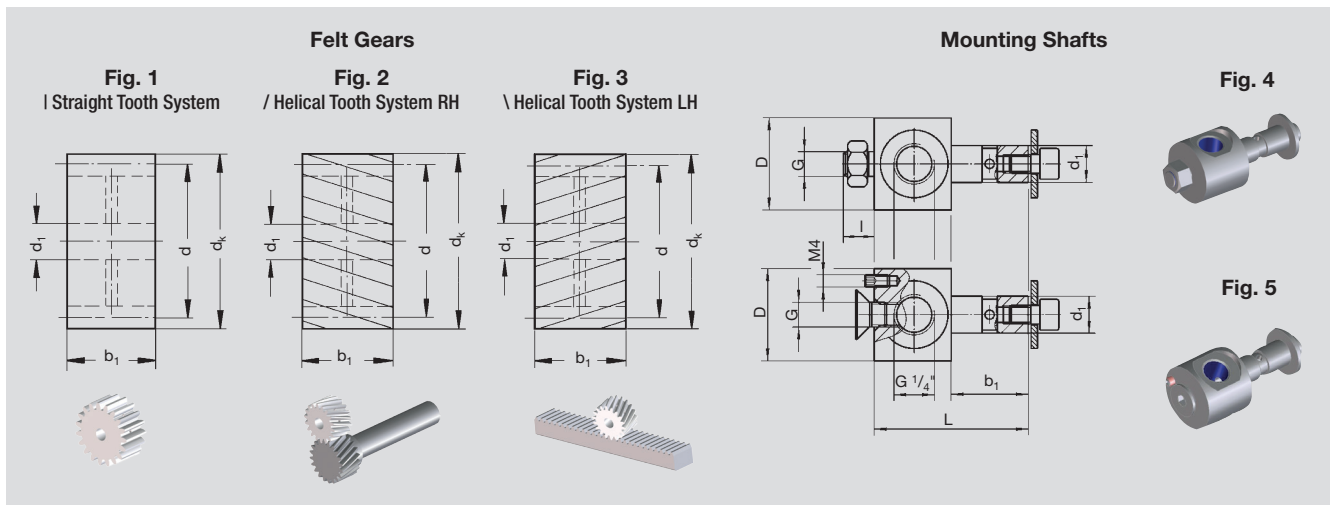

Order Code	Fig.	Module	Pitch	Flank Direction	No. of Teeth	d	d _k	d ₁	b ₁	D	L	I	G	
65 91 617	3	6		\	17	108.2	120.0	20	60					234.0
65 91 618	1	6			18	108.0	120.0	20	60					234.0
65 91 629	2	6		/	17	108.2	120.0	20	60					234.0
65 91 600	4	6						20	60	50	85	15	M12	545.0
65 91 610*	5	6						20	60	40	85		M8	535.0
65 91 620**	5	6						20	60	40	97		M8	550.0
65 91 817	3	8		\	17	144.3	160.0	20	80					562.0
65 91 818	1	8			18	144.0	160.0	20	80					562.0
65 91 829	2	8		/	17	144.3	160.0	20	80					562.0
65 91 800	4	8						20	80	50	105	15	M12	595.0
65 91 810*	5	8						20	80	50	105		M8	280.0
65 91 820**	5	8						20	80	50	118		M8	600.0
65 91 117	3	10		\	17	180.4	200.0	25	100					750.0
65 91 118	1	10			18	180.0	200.0	25	100					750.0
65 91 129	2	10		/	17	180.4	200.0	25	100					750.0
65 91 101	4	10						25	100	50	125	15	M12	650.0
65 91 111	5	10						25	100	50	125		M8	645.0
65 91 114	3	12		\	14	178.3	202.0	25	100					800.0
65 91 115	1	12			15	180.0	204.0	25	100					800.0
65 91 124	2	12		/	14	178.3	202.0	25	100					800.0
65 91 102	4	12						25	100	50	145	15	M12	830.0
65 91 112	5	12						25	100	50	145		M8	810.0

* For use with HP/E/B Gear Units

** For use with HT Gear Units



Sliding Brush Lubrication

Reducer

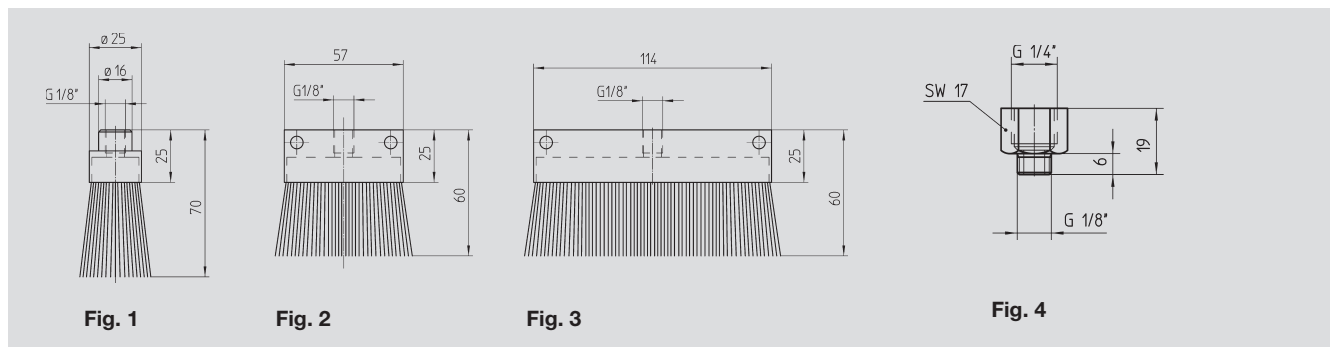

Order Code	Fig.	Description	For Module	g
65 91 010	1	Sliding -type lubricating brush, round, with internal thread	1, 1.5, 2, 3, 4	17
65 91 011	2	Sliding -type lubricating brush, flat, with internal thread	5, 6, 8	20
65 91 012	3	Sliding -type lubricating brush, flat, with internal thread	10, 12	40
9 08 05 003	4	Reducer		8

The sliding brush (of M_s with sturdy Nylon bristles) can be used in combination with our lubricators for lubricating either the rack or the pinion. During the assembly of the sliding brush onto the lubricator with 125 cm³ or the house-connection set, the existing lubricator reducer (Fig. 4) must be used. Using the lubricator with 475 cm³ the existing lubricator reducer must be used in combination with the reducer out of Fig. 4.

Hose Connection Set

Non-Return Valve

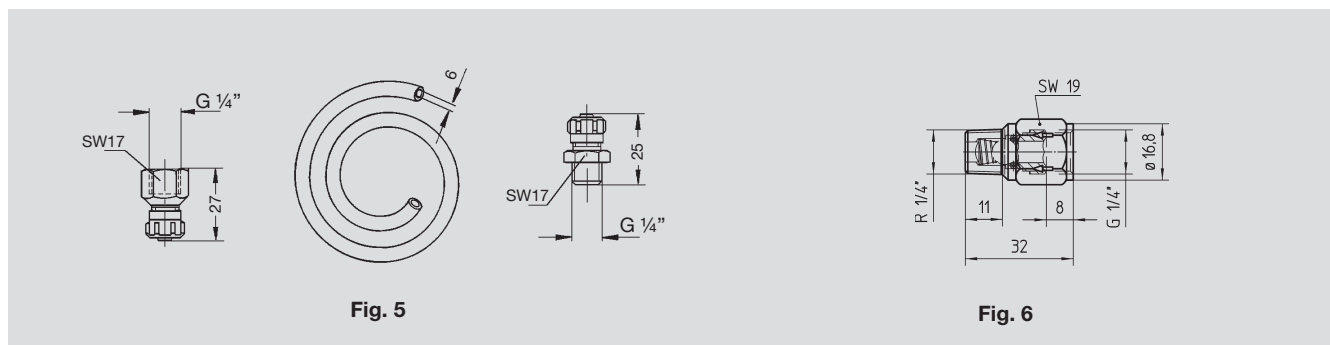

Order Code	Fig.	Description	g
65 91 020	5	Hose-connection set comprising: 2 m plastic hose Alumin. hose coupling with inside thread Alumin. hose coupling with outside thread	25
65 91 021	5	Hose-connection set comprising: 2 m plastic hose filled with GB0 Alumin. hose coupling with inside thread Alumin. hose coupling with outside thread	25
65 91 025	6	Non-return valve 0.2 bar	

Remark:

Before starting the hose-connection set must be filled up with lubricant. Lubrication see on page ZE-4.





Lubrication Information

Lubricator Assemblies for gear unit center distances 50 mm to 125 mm

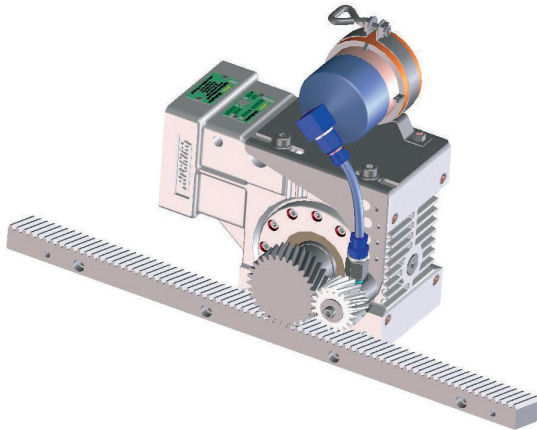

Lubricator Assemblies for center distance 32 mm available on request

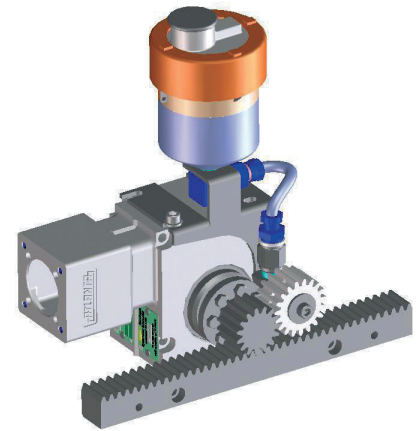

Lubrication by means of felt gear

Check-valve, if lubricating point is lower than lubricator

Non-lubricated length

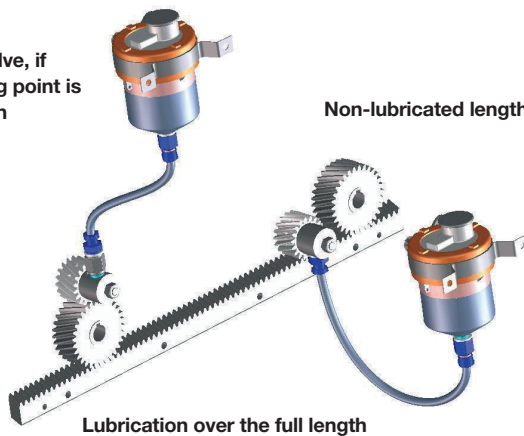

Lubrication over the full length

Lubrication by means of sliding brush

Reducer 1/4" to 1/8" required and check valve

Non-lubricated length

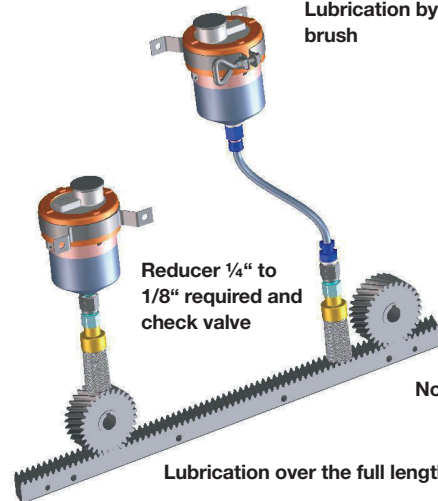

Lubrication over the full length

Lubrication of 2 lubrication points

Lube lines equally long
lubricator type 475 cm³ recommended
Check-valve recommended at both lubrication points



Lubrication by means of felt gear is possible in any position



Lubrication with sliding brush limited to max. 60° tilt

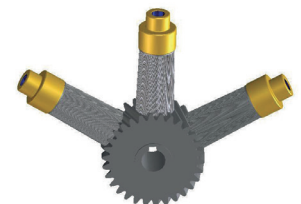

- Important information for optimum lubrication:
- Lube lines filled with lubricant
 - Felt gear or sliding brush soaked with lubricant
 - Pressure available in lubricant metering device
 - Dosage properly set at lubricant metering device



	Chapter
 Companion Racks	ZF-2
 Rack Mounting	ZF-3
 Rack Assembly Kit	ZF-4





Companion Racks for Straight Tooth System

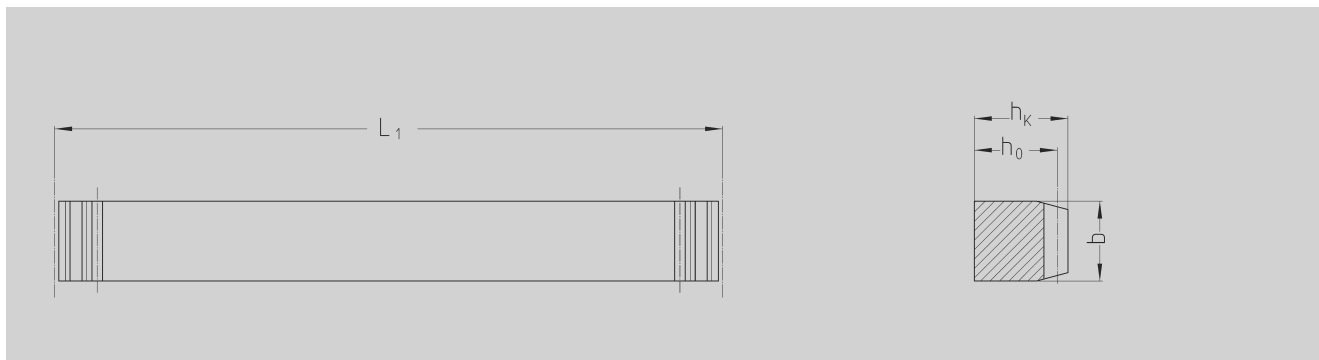

Order Code	Module	Pitch	L ₁	N° of Teeth	b	h _k	h ₀	kg
28 11 999	1		141.37	45	15	15	14.0	0.25
28 15 999	1.5		141.37	30	17	17	15.5	0.29
28 16 999		5	140.00	28	17	17	15.4	0.32
28 20 999	2		188.49	30	25	24	22.0	0.82
28 30 999	3		188.49	20	30	29	26.0	1.15
28 31 999		10	180.00	18	30	29	25.8	1.23
28 40 999	4		188.49	15	40	39	35.0	2.07
28 42 999		13.33	186.62	18	40	39	34.7	2.28
28 50 999	5		251.32	16	50	39	34.0	3.25
28 60 999	6		245.04	13	60	49	43.0	4.83
28 80 999	8		251.32	10	80	79	71.0	11.08
28 10 999	10		219.91	7	80	79	69.0	10.67
28 12 999	12		263.90	7	100	87	89.0	18.10

Companion Racks for Helical Tooth System

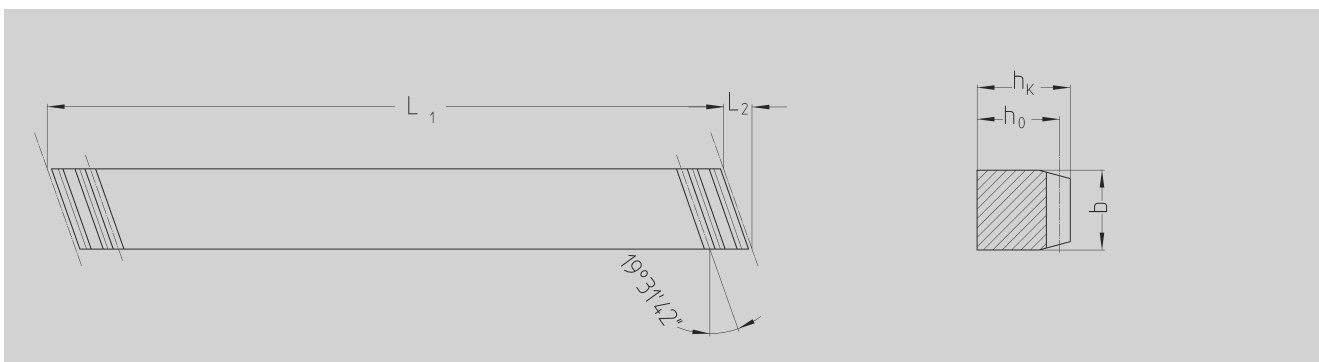

Order Code	Module	L ₁	L ₂	N° of Teeth	b	h _k	h ₀	kg
29 15 999	1.5	155.60	5.34	30	17	17	15.5	0.31
29 20 999	2	200.00	8.50	30	25	24	22.0	0.85
29 30 999	3	200.00	10.30	20	30	29	26.0	1.20
29 40 999	4	200.00	13.80	15	40	39	35.0	2.70
29 50 999	5	200.00	17.40	12	50	39	34.0	3.00
29 60 999	6	200.00	20.90	10	60	49	43.0	4.40
29 80 999	8	213.33	28.00	8	80	79	71.0	9.50
29 10 999	10	233.30	28.02	7	80	79	69.0	9.92
29 12 999	12	280.00	35.11	7	100	99	87.0	19.20



- Teeth induction-hardened and ground
- Material C45.

Companion racks left-hand for right-hand racks.



Order Code	Screws	Pin	Rack
28.02.151	M5 x 20	D6 m6 x 24	Module 1.5/47.15.xxx
28.02.152	M6 x 20	D6 m6 x 28	Module 1.5
28.02.202	M6 x 25	D6 m6 x 30	Module 2
28.02.203	M8 x 25	D10 m6 x 36	Module 2/Strongline
28.02.302	M8 x 30	D8 m6 x 40	Module 3
28.02.303	M10 x 35	D12 m6 x 45	Module 3/Strongline
28.02.402	M8 x 40	D8 m6 x 50	Module 4/xx.40.xxx
28.02.403	M14 x 45	D16 m6 x 60	Module 4/Strongline
28.02.404	M12 x 45	D12 m6 x 55	Module 4/xx.42.xxx
28.02.502	M12 x 55	D12 m6 x 70	Module 5
28.02.503	M16 x 55	D16 m6 x 70	Module 5/Strongline
28.02.602	M16 x 65	D16 m6 x 80	Module 6
28.02.802	M20 x 90	D20 m6 x 100	Module 8
28.02.112	M30 x 110	D20 m6 x 120	Module 10
28.02.122	M36 x 130	D20 m6 x 140	Module 12

Content of bag:8 screws + 2 pins $\hat{=}$ 1 meter of rack

Screws: DIN EN ISO 4762 12.9

Pins: DIN 7979 (ISO 8735-A)





Order Code	Description	Module	Relative Item No.		kg
			Helical	Straight	
29.01.002	Assembly kit, comprising: 1 x Adjusting device 3 x Gauging roller with magnet 1 x Measuring bridge with dial gauge	2	29.20.xxx 38.21.xxx 39.20.xxx 47.20.xxx	28.20.xxx 33.21.xxx 34.20.xxx 49.29.xxx	0.40
29.01.003	Assembly kit, comprising: 1 x Adjusting device 3 x Gauging roller with magnet 1 x Measuring bridge with dial gauge	3	29.30.xxx 38.31.xxx 39.30.xxx 47.30.xxx	28.30.xxx 33.31.xxx 34.30.xxx 49.39.xxx	0.44
29.01.004	Assembly kit, comprising: 1 x Adjusting device 3 x Gauging roller with magnet 1 x Measuring bridge with dial gauge	4	29.40.xxx 38.41.xxx 39.40.xxx 47.40.xxx	28.40.xxx 33.41.xxx 34.40.xxx 49.49.xxx	0.55
29.01.005	Assembly kit, comprising: 1 x Adjusting device 3 x Gauging roller with magnet 1 x Measuring bridge with dial gauge	5	29.50.xxx 38.51.xxx 39.50.xxx 47.50.xxx	28.50.xxx 33.51.xxx 34.50.xxx	0.8
29.01.006	Assembly kit, comprising: 1 x Adjusting device 3 x Gauging roller with magnet 1 x Measuring bridge with dial gauge	6	29.60.xxx 39.60.xxx 47.60.xxx	28.60.xxx 34.60.xxx	0.90
29.01.008	Assembly kit, comprising: 1 x Adjusting device 3 x Gauging roller with magnet 1 x Measuring bridge with dial gauge	8 helical	29.80.xxx 47.80.xxx		1.35
28.01.008	Assembly kit, comprising: 1 x Adjusting device 3 x Gauging roller with magnet 1 x Measuring bridge with dial gauge	8 straight		28.80.xxx	1.15
29.01.010	Assembly kit, comprising: 1 x Adjusting device 3 x Gauging roller with magnet 1 x Measuring bridge with dial gauge	10	29.10.xxx 47.10.xxx	28.10.xxx	1.40
29.01.012	Assembly kit, comprising: 1 x Adjusting device 3 x Gauging roller with magnet 1 x Measuring bridge with dial gauge	12	29.12.xxx	29.13.xxx	1.50





Order Code	Description	Module	Relative Item No.		kg
			Helical	Straight	
29.01.102	Assembly kit, comprising: 1 x Adjusting device 3 x Gauging roller with magnet 1 x Measuring bridge with dial gauge	2	29.25.xxx	28.25.xxx	0.40
29.01.103	Assembly kit, comprising: 1 x Adjusting device 3 x Gauging roller with magnet 1 x Measuring bridge with dial gauge	3	29.35.xxx	28.35.xxx	0.44
29.01.104	Assembly kit, comprising: 1 x Adjusting device 3 x Gauging roller with magnet 1 x Measuring bridge with dial gauge	4	29.45.xxx	28.45.xxx	0.55
29.01.105	Assembly kit, comprising: 1 x Adjusting device 3 x Gauging roller with magnet 1 x Measuring bridge with dial gauge	5	29.55.xxx	28.55.xxx	0.8



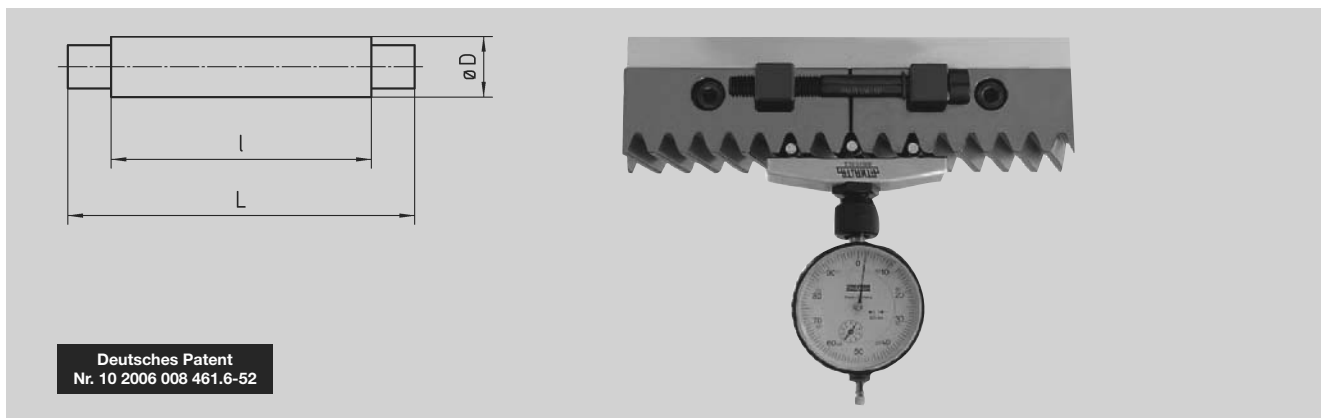

Deutsches Patent
Nr. 10 2006 008 461.6-52

Order Code	Description	Module	L	I	D	
1.29.00.042	3 x Gauging roller with magnet	2	28	20	4.2	2
1.29.00.050	3 x Gauging roller with magnet	3	33	25	5	5
1.29.00.070	3 x Gauging roller with magnet	4	40	30	7	15
1.29.00.090	3 x Gauging roller with magnet	5	42	34	9	20
1.29.00.100	3 x Gauging roller with magnet	6	43	35	10	25
1.29.00.140	3 x Gauging roller with magnet	8	45	35	14	45
1.29.00.180	3 x Gauging roller with magnet	10	42	35	18	75
1.29.00.200	3 x Gauging roller with magnet	12	50	43	20	75

Material: hardened steel.

Description:

The gauging rollers (patent) are placed in the tooth gaps of the already mounted rack, of the rack to be mounted, and in the gap at the joint. Adjust the measuring bridge on a measuring plate or other level surface to zero. Mount the adjusting device. By means of the measuring bridge and the adjusting device it is now possible to adjust the optimal pitch by moving the racks to be assembled. The pointer of the dial gauge should, if possible, reach the pre-set zero value.

Measuring Bridge

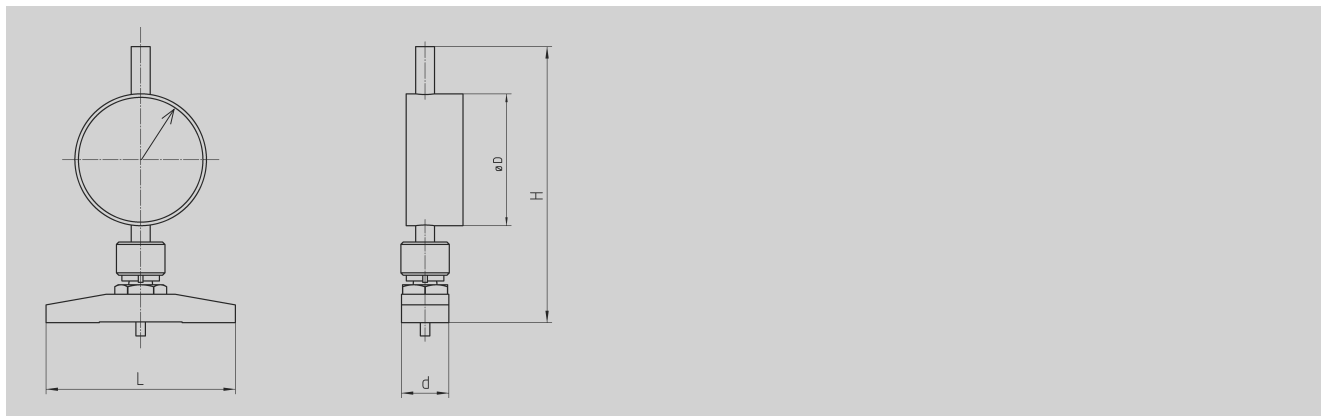

Order Code	Description	Module	L	b	H	D	
2.28.01.008	Measuring bridge	2 - 4	80	20	115	58	310
2.28.01.015	Measuring bridge	5 - 12	150	20	120	58	420



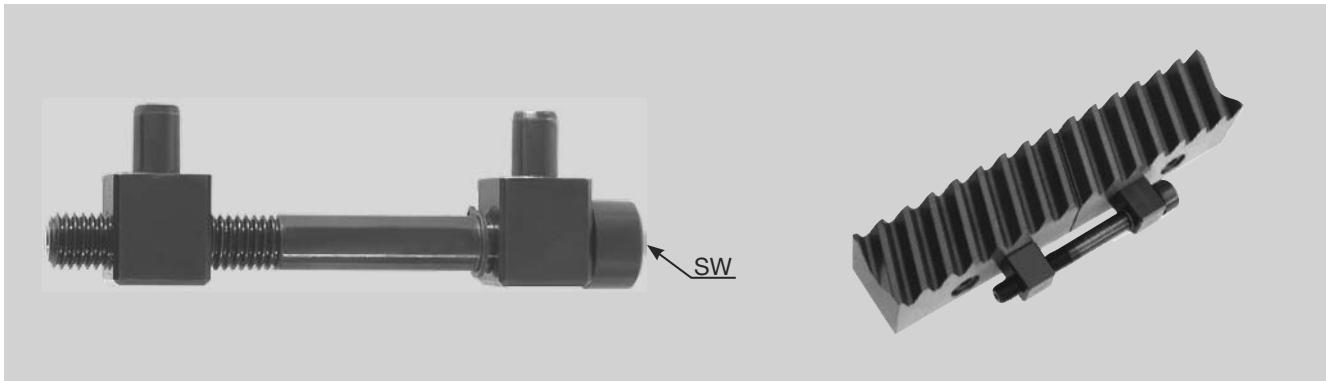

Order Code	Description	SW	Module	Relative Item No.		kg
				Helical	Straight	
2.29.00.002	Adjusting device	5	2	29.20.xxx 38.21.xxx 39.20.xxx 47.20.xxx	28.20.xxx 33.21.xxx 34.20.xxx 49.29.xxx	0.12
StrongLine 2.29.00.102	Adjusting device	5	2	29.25.xxx	28.25.xxx	0.12
2.29.00.003	Adjusting device	6	3 + 4	29.30.xxx 38.31.xxx 39.30.xxx 47.30.xxx 29.40.xxx 38.41.xxx 39.40.xxx 47.40.xxx	28.30.xxx 33.31.xxx 34.30.xxx 49.39.xxx 28.40.xxx 33.41.xxx 34.40.xxx 49.49.xxx	0.14
StrongLine 2.29.00.103	Adjusting device	6	3	29.35.xxx	28.35.xxx	0.14
StrongLine 2.29.00.104	Adjusting device	6	4 + 5	29.45.xxx 29.55.xxx	28.45.xxx 28.55.xxx	0.03
2.29.00.005	Adjusting device	10	5	29.50.xxx 38.51.xxx 39.50.xxx 47.50.xxx	28.50.xxx 33.51.xxx 34.50.xxx	0.3
2.29.00.006	Adjusting device	14	6	29.60.xxx 39.60.xxx 47.60.xxx	28.60.xxx 34.60.xxx	0.44
2.29.00.008	Adjusting device	14	8 – 12	29.80.xxx 47.80.xxx 29.10.xxx 47.10.xxx	28.10.xxx	0.82
2.28.00.008	Adjusting device	14	8 straight		28.80.xxx	0.46

By fitting the adjusting device (patent pending) in the pinholes of the rack it is possible to move the rack to be assembled axially in both directions by turning the screw. This permits to adjust the correct dimension over rollers and the accurate pitch at the rack joint. The adjusting device is held in place on the rack by means of magnetic force and can be used in any mounting position. Up to module 6 the wrench sizes correspond to the rack mounting screws.





Mounting Instructions

Racks

To make it possible to link our standard racks to form any desired length, the teeth are cut so that there is half a tooth gap at each end of the rack. The opposite diagram shows how rack 1 and rack 2 can be brought into the correct pitch position. Fitting aids with teeth cut in the opposite direction are available for linking helical-tooth systems. See page ZF-2. The best mounting results can be achieved with the Rack Assembly Kits. Description see page ZF 10.

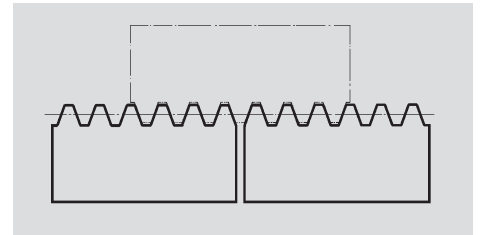

The mounting screws are to be tightened to the torque of socket head cap screws 12.9 using a torque wrench and table. For the 0.5 m long racks it is absolute necessary to use the pin holes.

At rack and pinion drives, the pitch lines of pinion and rack has to be parallel. To check this, we recommend using a bluing compound and check the gear mesh contact pattern under load conditions. The backlash in between rack and pinion has to be adjusted at the high point. The backlash should be according to the table.

Thread	M5	M6	M8	M10	M12	M14	M16	M20	M30	M36
Tighten torque	9 Nm	16 Nm	40 Nm	76 Nm	135 Nm	210 Nm	340 Nm	660 Nm	2300 Nm	4100 Nm

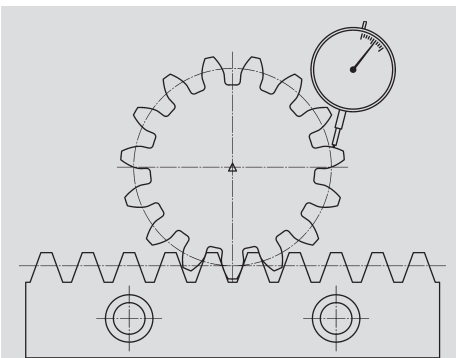

Recommended Backlash for Rack Quality Used:

- Q3: min. 0.010
- Q5: min. 0.011
- Q6: min. 0.027 (m= 1,5 - 4) / min.0.020 (m= 5 - 6)
- Q7: min. 0.037 (m= 1,5 - 4) / min.0.028 (m= 5 - 6)
- Q8: min. 0.043 (xx.xx.xx8) / 0.080 (xx.xx.xx0)
- Q9: min. 0.080
- Q10: min. 0.080
- Max: Module 2-12
- Max: Module 1.5

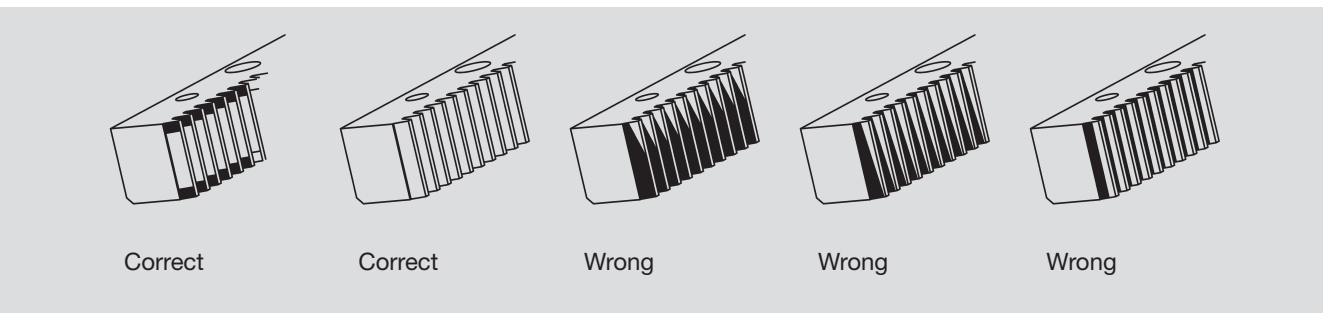



Relationship between tooth thickness and roller ball measurement:

The tooth thickness of racks is usually measured via the roller ball measurement as the tooth thickness could not be measured directly. A measuring roller is put into the teeth and measured to the back of the rack.

So tooth thickness tolerances could be measured by recalculating of the roller ball measurement.

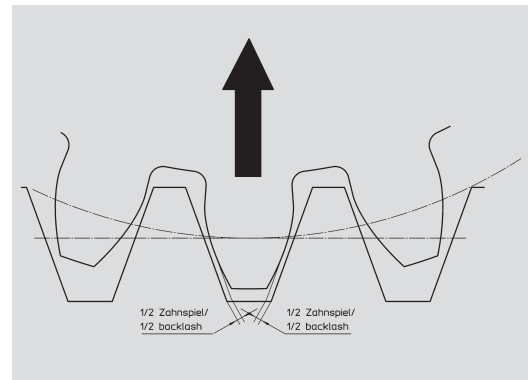
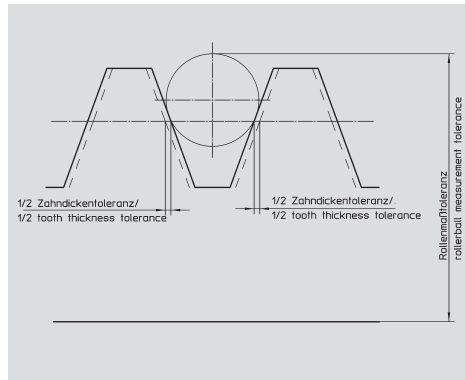
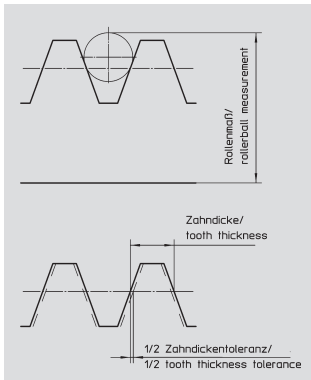

Tooth Thickness Tolerance	Roller Ball Measurement Tolerance	Desired Backlash	Change In Center Distance
0.01	0.014	0.01	0.014
0.02	0.027	0.02	0.027
0.03	0.041	0.03	0.041
0.04	0.055	0.04	0.055
0.05	0.069	0.05	0.069
0.06	0.082	0.06	0.082
0.07	0.096	0.07	0.096
0.08	0.110	0.08	0.110
0.09	0.124	0.09	0.124
0.10	0.137	0.10	0.137
0.11	0.151	0.11	0.151





Description

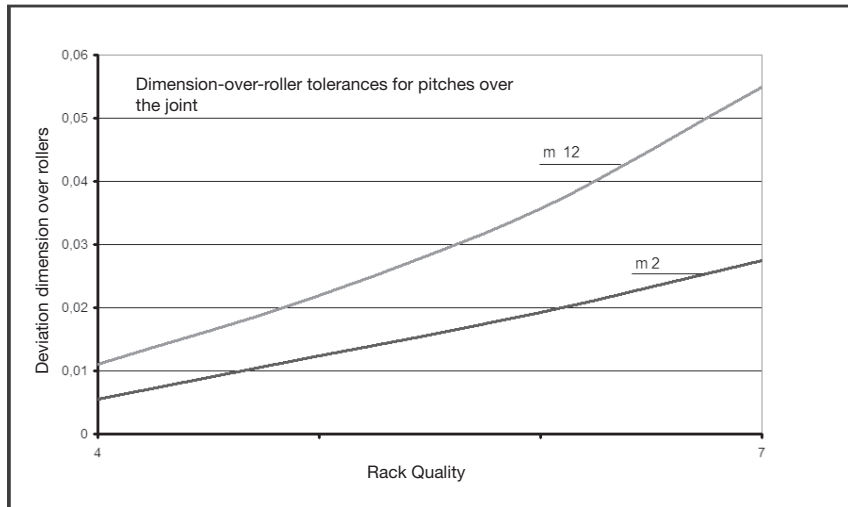

ATLANTA gear racks can be mounted end-to-end with the correct gap pitch by means of a companion rack or rack assembly kit. After positioning the racks for assembly insert the fixing screws of the rack and slightly turn them in by hand.

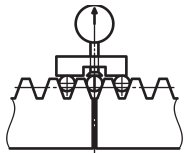

Fig. 1

Arrange the rack adjusting device in the existing pinholes of the racks. The device is held in position on the racks by magnetic force. Any mounting position is possible.

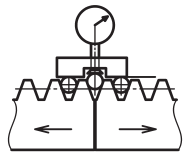

Fig. 2

The gauging rollers are inserted in the two adjacent racks and in the gap at the joint. They, too, are held in place in the tooth space by magnetic force and can therefore be used in any mounting position of the racks. It is thus ensured that they are always accurately positioned on the tooth flanks. The tooth gaps must be free from residues or any other foreign matter.

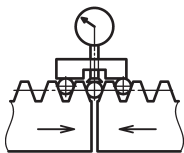

Fig. 3

With the measuring bridge set to zero on a measuring plate or another level surface it is now possible to measure the variation of the dimension over the roller. The exact pitch at the joint can then be adjusted by moving the rack with utmost precision in either direction. The sketch shows the excellent toothing quality obtained based on the variation of the dimension over rollers at the joint of the racks.

It is therefore no longer necessary to adjust the rack by tapping with a hammer. The slightly pre-stressed rack is put in the correct position and held in this position until it is screwed together.





Safety Instructions

The following preventive measures are necessary:

Ensure there can be no contact with rotating parts (for example output shaft, spur wheel, rack) and gearbox-bolts are tight. Contact with lubricant must be avoided. Refer to data sheet.

Finishing

Gears serial no. 24.98.xxx/24.99.xxx are carburized and the teeth induction hardened. Finishing according to customers request is possible.

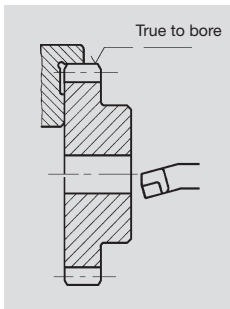

All soft spur gears of our off-the-shelf program range with order code series 06/07/21/22 and 23 are prebored and thus can be finished by us or by the customer to the required mounting dimensions (turning of inside diameter, boring, keyseating, hardening, etc.). In order to ensure proper functioning of the finished spur gears it is important to consider not only the toothing quality but also the concentricity in relation to the mounting bore. This should be born in mind when choosing the appropriate machining process. Since the outside diameter of our standard gears is turned in one operation true to the mounting bore and/or hobbled when cutting the teeth, we recommend to proceed as shown on the opposite sketch.

All standard spur gears with one-sided hub as well as certain plate wheels (for material, see the dimension tables) are manufactured from normalized heat treatable steel C45 (Material No. 1.0503). If a higher strength is required, these drive elements of C 45 can be quenched and tempered or optionally the teeth can be flame or induction hardened (approx. 50 HRC). Fitting surfaces should be finished only after induction-hardening. Be sure to observe the relevant regulations when flame- or induction-hardening our off-the-shelf standard gears.

Maximum bore diameter of the pinion on request.





1 Berlin/Brandenburg/

Thüringen/Sachsen

Wolfgang Wirth
 August-Bebel-Straße 11
 D-04618 Ziegelheim
 Telefon 034494-80880
 Telefax 034494-80881
 Mobil: 01 70-5 63 61 58
 E-Mail: wwirth@atlantagmbh.de

5 Hamburg/Bremen/Schleswig-

Holstein/Niedersachsen/

Westfalen/Sachsen-Anhalt

Uwe Hilz Ingenieurbüro
 Vetriebsstützpunkt Nord
 Rothemühleweg 26
 D-38112 Braunschweig
 Telefon 0531-252600
 Telefax 0531-2526026
 E-Mail: uhilz@hilz.de
 Internet: www.hilz.de

4 Rheinland-Pfalz/Nord

Lahme Engineering
 Dipl.-Ing. Andreas Lahme
 Kapellstr. 21
 D-40479 Düsseldorf
 Telefon 02 11-40894 10
 Telefax 02 11-4790356
 Mobil: 01 73-9 07 62 74
 E-mail: lahme-engineering@t-online.de

6 Rheinland-Pfalz-Ost

Klaus Hehn
 Berliner Straße 17
 D-65824 Schwalbach am Taunus
 Telefon 06196-20260 10
 Telefax 06196-20260 11
 Mobil: 01 51-21 25 84 81
 E-Mail: khehn@atlantagmbh.de

7/1 Baden-Württemberg

Ralf-Thomas Schmidt
 Wilhelmstraße 20
 D-74321 Bietigheim-Bissingen
 Telefon 07142-91 49 89
 Telefax 07142-91 41 54
 Mobil 0163-5 78 32 76
 E-Mail: schmidt@rts-antriebssysteme.de

7/2 Baden-Württemberg

Lutz Antriebstechnik GmbH
 Dr.-Ing. Michael Lutz
 Weiherwiesen 13
 D-90559 Burgthann
 Telefon 09183-90 18 01
 Telefax 09183-90 18 02
 E-Mail: michael.lutz@lutz-antriebstechnik.de

8 Bayern

Markus Wiesert
 Hauptstraße 9a
 86922 Eresing
 Telefon: 07142-3442573
 Telefax: 07142-700199
 Mobil: 0176-8331358
 E-Mail: mwiesert@atlantagmbh.de

11 Saarland

Robert Müller
 Antriebstechnik R. Müller GmbH
 Eifelstraße 4
 D-66333 Völklingen
 Telefon 06898-87 05 18
 Telefax 06898-87 05 43
 Mobil: 01 77-8 04 98 38
 E-Mail: info@antriebstechnik-mueller.de





© Fotolia



USA USA

CDN Canada

ATLANTA Drive Systems, Inc.
1775 Route 34, Unit D-10
USA – Farmingdale, NJ 07727
Tel.: 001-800 505-1715
Fax: 001-732 282-0450
E-Mail: info@atlantadrives.com
Internet: www.atlantadrives.com

F France

ATLANTA Neugart France S.A.R.L.
9, Rue Georges Charpak
F-77127 Lieusaint
Tel.: 0033-164 05 36 16
Fax: 0033-164 05 36 17
E-Mail: info@atlanta-neugart.com
Internet: www.atlanta-neugart.com

CN People's Republic of China

ATLANTA Drive Technology
(Shanghai) Co., Ltd.
Suite 10E, No.88 Dapu Road
Postal Code 200023, Shanghai
Tel.: +86 (21) 50485680
Fax: +86 (21) 50485683
E-Mail: info@atlanta-drives.cn
Internet: www.atlanta-drives.cn





With 23 agent offices in all industrialized countries of the world, we are available around the globe. Project consulting, high availability of needed items and short delivery times make us as a flexible and reliable partner for drive technology.

A Austria

TAT-Technom Antriebstechnik GmbH
Haidbachstr. 1
A – 4061 Pasching
Tel.: 0043-7229-64840-0
Fax: 0043-7229-61817
E-Mail: tat@tat.at
Internet: www.Tat.at

B Belgium

Vansichen Lineairtechniek BVBA
Herkenrodesingel 4 bus 3
B – 3500 Hasselt
Tel.: 0032 (0) 11-37 79 63
Fax: 0032 (0) 11-37 54 34
E-Mail: vansichen@vansichen.be
Internet: www.vansichen.be

BR Brazil

Automotion Ind. Com. Imp. e Exp. Ltda.
Acesso José Sartorelli Km 2,1
BR-Boituva/SP - CEP 18550-000
Tel.: 0055-15-3363-9900
Fax: 0055-15-3363-9911
E-Mail: info@automotion.com.br
Internet: www.automotion.com.br

CN China

Tianjin Ace Pillar Enterprise Co., Ltd.
No. 3 West 10 Ave,
Tianjin Airport Ind. Park
Postal Code 300308, Tianjin, China
Tel.: 0086-22-23556000
Fax: 0086-22-23556368
E-Mail: sales@acepillar.com.cn
Internet: www.acepillar.com.cn

CZ Czech Republic

TAT – pohonová technika spol.s r.o.
Hranicni 53
CZ – 370 06 České Budejovice
Tel.: 00420-387-414-414
Fax: 00420-387-414-415
E-Mail: tat@cz.tat.at
Internet: www.cz-tat.cz

DK Denmark

CfT Tandhjulsfabrik A/S
Ravnsbjergvej 8, Sosum
DK – 3670 Vekso
Tel.: 0045-4717 0260
Fax: 0045-4717 0105
E-Mail: cft@internet.dk
Internet: www.cft.dk

SF Finland

EIE Maskin OY
Asematie 1
FI – 10600 Tammisaari
Tel.: 00358-19-2239 100
Fax: 00358-19-2239 199
E-Mail: info@eie.fi
Internet: www.eie.fi

GB Great Britain

IRL Ireland

HMK Technical Services Ltd.
Kappa House, Hatter Street
GB – Congleton, Cheshire, CW 12 1QJ
Tel.: 0044-(0)1260 279 411
Fax: 0044-(0)1260 281 022
E-Mail: sales@hmkdirect.com
Internet: www.hmkdirect.com

GR Greece

gt-kyma
Theodoridis Georgios
Meseo, PO Box 4
GR – 54500 Thessaloniki
Tel.: 0030 231 078 60 02
Fax: 0030 231 001 18 12
E-Mail: info@gt-kyma.com
Internet: www.gt-kyma.com

IND India

Fluro Engineering PVT LTD
Plot no: B 29 / 1 MIDC
IND – Taloja – 410 206
Raigad - Navi Mumbai
Tel.: 0091-22-2741 1922
Fax: 0091-22-2741 1933
E-Mail: sales@fluroengg.com
Internet: www.fluroengg.com

I Italy

ATLANTA Antriebssysteme
E. Seidenspinner GmbH & Co. KG
Signore Silvio Bongiovanni
Carl-Benz-Str. 16
D-74321 Bietigheim-Bissingen
Tel.: 0049 (0) 7142-7001 152
Fax: 0049 (0) 7142-7001 19152
E-Mail: sbongiovanni@atlantagmbh.de
Internet: www.atlantagmbh.de



**(ROK) Korea**

Intech Automation Inc.
2-1504, Ace Hitech City 55-20
Mulla-Dong 3-Ga
Youngdeungpo-Ku,
ROK – Seoul - Korea 150-972
Tel.: 0082-2-3439-0070-4
Fax: 0082-2-3439-0080
E-Mail: intech@intechautomation.co.kr
Internet: www.intechautomation.co.kr

(NL) Netherlands

Reich-aandrijftechniek b.v.
Spanjelaan 24
NL – 9403 DP Assen
Tel.: 0031-592 266 000
Fax: 0031-842 100 855
E-Mail: info@reich-aandrijftechniek.nl
Internet: www.reich-aandrijftechniek.nl

(N) Norway

EIE Maskin AS
Tvetenveien 164
N – 0671 Oslo
Tel.: 0047- 6757-2270
Fax: 0047- 2275-5107
E-Mail: elmeko@elmeko.no
Internet: www.elmeko.no

(PL) Poland

Pivexin Technology sp. z o.o.
ul. Jana Pawla II 2
PL – 47-440 Nedza
Tel.: +48 32 412 30 12
Fax: +48 32 414 91 55
Mail: info@pivexin-tech.pl
Internet: www.pivexin-tech.pl

(RUS) Russia

Bibus o.o.o.
Izmailovsky prospect 2 A
RUS-19005 Saint Petersburg
Tel.: 007-812-251 62 71
Fax: 007-812-251 90 14
E-Mail: info@bibus.ru
Internet: www.bibus.ru

(SGP) Singapore

Imao Machine Components
2 Yishun Industrial Street 1 #04-04
North Point Bizhub
Singapore 768159
Tel.: 0065-6894-1617
Fax: 0065-6894-1619
E-Mail: info@imao-ind.com
Internet: www.imao-ind.com

(SK) Slovakia

Rastech s.r.o.
Buzulucká 3
SK – 96150 Zvolen
Tel.: 00421-45 547 9806
Fax: 00421-45 547 9806
E-Mail: pleva@rastech.sk

(E) Spain

Brotomatic S.L.
C/San Miguel de Acha, N°2 P3
E – 01010 Vitoria-Gasteiz
Tel.: 0034-945-249411
0034-945-249776
Fax: 0034-945-227832
E-Mail: brotom@brotomatic.es
Internet: www.brotomatic.es

(S) Sweden

EIE Maskin AB
Box 7
S – 124 21 Bandhagen
Tel.: 0046-(0)8-727-8800
Fax: 0046-(0)8-727-8897
E-Mail: eie@eie.se
Internet: www.eie.se

(CH) Switzerland

RELEX AG Antriebstechnik
Schachenstrasse 80
CH – 8645 Jona SG
Tel.: 0041-(0)55 225 46 11
Fax: 0041-(0)55-225 46 19
E-Mail: kontakt@relex.ch
Internet: www.relex.ch

(RC) Taiwan

Ace Pillar Co., Ltd.
2F, No. 7 Lane 83 Section 1
Kuang-Fu Road
San-Chung City
Taipei Taiwan, ROC
Tel.: 00886-2-2995-8400
Fax: 00886-2-2995-3466
E-Mail: pillar@ms1.hinet.net

(TR) Turkey

EKSIM Mühendislik Ltd. Sti.
Perpa Ticaret Merkezi B-Blok Kat: 11
TR – 1675 Istanbul
Tel.: 0090-(0)212 222 81 12
Fax: 0090-(0)212 222 81 02
E-Mail: info@eksimmuhendislik.com
Internet: www.eksimmuhendislik.com



**1. General Provisions**

- I. These General Terms shall apply to all deliveries and services which we, Atlanta Antriebssysteme E. Seidenspinner GmbH & Co. KG, provide or make to business owners (purchasers).
- II. Purchase conditions of the purchaser which conflict with, supplement the scope of, or deviate from these General Terms shall not become part of the contract unless we explicitly agree to their application in writing. This approval requirement shall also apply if we carry out a delivery to the purchaser without reservations while being aware of the purchaser's conflicting or deviating conditions.

2. Conclusion of Contract and Implementation

- I. All our offers are without engagement and non-binding.
- II. A contract does not exist until we issue a written confirmation of the order or an invoice. If we do not reply to offers, orders, requests, or other declarations of the purchaser, this shall only be deemed consent if an express written agreement to this effect has been made.
- III. Pictures, drawings, information as to weights, measures, colors and performance, and any other descriptions of the goods in the documents which form part of the offer are approximations only unless they are expressly stated to be binding. They do not constitute any agreement on or guarantee of a corresponding quality of the goods.
- IV. We retain our ownership of and/or our copyrights and other property rights in all our samples, sketches, patterns, cost estimates, dies, tools, drawings, and similar items, as well as in any information, whether tangible or intangible (including in electronic form). Such items or information may only be made available to third parties with our prior written consent and, at our request, must be returned to us without undue delay and free of charge along with any copies made; documents which have been stored electronically must be deleted.
- V. In the case of custom-made products, **deliveries which exceed or fall short of the quantity ordered by up to 10%** shall be deemed to be as agreed.
- VI. In the absence of a separate agreement, requests for delivery within the scope of orders for delivery upon request must be made within one year of the order date. Otherwise, we may deliver and issue an invoice for the goods, withdraw from the contract or, if the purchaser has acted culpably, claim damages in lieu of performance after setting a reasonable additional time period for performance to no avail. In addition, we may charge the purchaser for the quantities actually requested at the applicable prices.
- VII. Tools manufactured by us on behalf of the purchaser will remain our property even if we charge the purchaser for part of the cost of manufacturing the tools.
- VIII. If the purchaser provides us with parts for processing ("parts to be provided"), the following rules shall apply: The parts to be provided must be delivered along with a delivery note. In this delivery note, we must be informed of the number and material of these parts. We need gauge pieces for setting our machines. **If we do not receive any other information from the purchaser, we may take the required number of gauge pieces from the quantity of the parts to be provided which the purchaser has supplied to us. This will be a minimum of 1 piece and a maximum of 10%** of the supplied quantity of parts to be provided. Complaints about shortfalls which result from the purchaser's failure to supply a sufficient quantity of the parts to be provided shall be excluded. The material used must allow optimal processing. All prefabricated parts supplied must be true to size and have the required tolerances; otherwise, we may return them at the purchaser's expense. We are not liable for defects which are due to the quality and, in particular, the material of the parts supplied. If parts become unusable as a result of faults in the material or defects for which we are not responsible, we may charge the purchaser for the processing costs incurred in this connection. We reserve the right to assert further claims for damages.

3. Delivery Periods; Default

- I. As a prerequisite for adherence to delivery periods, all commercial and technical issues must have been clarified, all documents and all required permits and approvals which need to be supplied by the purchaser and any parts to be provided pursuant to Sec. 2., subsection VIII above must have been timely received by us, and the purchaser must comply with the terms of payment and any other obligations agreed upon. The delivery period shall be reasonably extended if the prerequisites stipulated in the first sentence of this subsection I are not met in due time, unless we are responsible for the delay.
- II. Delivery by us shall be subject to the timely and proper receipt of the deliveries from our own suppliers. We will inform the purchaser as soon as possible if it becomes apparent that there will be a delay.
- III. Subsequent requests of the purchaser for changes to the order will result in an interruption of the delivery period until the desired change has been agreed upon. Thereafter, a reasonable new delivery period shall commence.
- IV. As a prerequisite for the purchaser's withdrawal from the contract following late delivery by us, we must have been given a reasonable additional period of time for performance which has expired to no avail.
- V. If delivery periods cannot be adhered to because of events of force majeure, e.g., mobilization, war, civil unrest, or similar events on which we have no influence, such as industrial action, the delivery periods shall be reasonably extended.



- VI. The delivery period will be deemed met if the goods have left our works or the purchaser has been given notice that the goods are ready for dispatch by the time the delivery period expires. In the event that a work must be accepted, the date for acceptance or, alternatively, the time of notice that the work is ready for acceptance shall be decisive unless acceptance is legitimately refused.
- VII. Claims for damages for late performance and claims for damages in lieu of performance shall be excluded in all cases of late delivery, even after the expiry of a deadline set to us by the purchaser for delivery. This shall not apply in cases of willful misconduct, gross negligence, or death, bodily injury or damage to health. The purchaser may only withdraw from the contract within the scope of the statutory provisions if we are responsible for the late delivery. The preceding provisions do not involve a reversal of the burden of proof to the purchaser's detriment.
- VIII. If so requested by us, the purchaser shall be obligated to state within a reasonable time period whether it withdraws from the contract due to the late delivery or whether it insists upon delivery.
- IX. We shall have the right to make partial deliveries unless this is unreasonable for the purchaser. The additional delivery costs incurred through such partial deliveries, if any, will be borne by us unless the partial delivery was requested by the purchaser.
- X. All goods will be dispatched at the purchaser's expense and risk, even if we are late with a delivery.

4. Passing of Risk

- I. The risk shall pass to the purchaser as soon as the goods have been delivered to the person in charge of carrying out the transport or as soon as the goods have left our warehouses for shipping purposes. This shall also apply if we make partial deliveries or if we have assumed further obligations, for example, the obligation to pay the transport costs or to install the goods at the purchaser's place of business. If so requested by the purchaser, we will take out a transport insurance policy and insure the goods at the purchaser's expense against the risks specified by the purchaser.
- II. If the purchaser defaults on acceptance or violates other cooperation duties, we may demand compensation for the damage sustained including our additional costs, if any. The risks of accidental loss or destruction or accidental deterioration of the goods shall pass to the purchaser as soon as the purchaser defaults on acceptance. After a reasonable time period set for acceptance has expired to no avail, we will have the right to otherwise dispose of the goods and carry out the delivery to the purchaser within a reasonably extended time period.

5. Retention of Title

- I. We retain title to all items delivered by us until all of our claims against the purchaser which arise from the business relationship have been fully settled.
- II. We have the right (but no obligation) to insure the goods to which title is retained at the purchaser's expense against theft, breakage, fire, water, damage in transit and any other damage unless the purchaser takes out a corresponding insurance policy itself or expressly objects to such insurance.
- III. For as long as the purchaser is not in default of payment, the purchaser may machine and process the goods to which title is retained in the ordinary course of its business on behalf of us as manufacturer within the meaning of Sec. 950 German Civil Code without such machining or processing giving rise to any obligations on our part. In such case, the following rules shall apply: any processing or alteration by the purchaser of the goods to which title is retained shall always be carried out on our behalf. The purchaser's right to acquire ownership of the goods to which title is retained shall continue to exist with respect to the processed or altered items. If the goods are processed, combined, or mingled with other items which are not our property, we will acquire a co-ownership interest in the new item pro rata to the value of the goods supplied as compared to the other processed items at the time of processing. The purchaser shall store the new items on our behalf. In the event that any third party obtains direct possession of the items, the purchaser assigns to us already now its existing or future claims for surrender. In all other respects, the items resulting from processing or alteration shall be governed by the same rules as the goods to which title is retained.
- IV. The purchaser is authorized, subject to revocation, to sell the goods to which title is retained in the ordinary course of its business, provided that the purchaser receives payment from its own customer or makes its own deliveries subject to retention of title so that ownership will not pass to the purchaser's customer until after the latter has performed its obligations to pay.
- V. The purchaser is not authorized to pledge or transfer the goods to which title is retained by way of security.
- VI. The purchaser assigns to us already now, by way of security, any and all receivables (including any current account balance claims) which may arise from resale or on any other legal grounds (in particular, from insurance contracts or tort) with respect to the goods to which title is retained.
- VII. The purchaser is authorized, subject to revocation, to collect the receivables which have been assigned to us on our account in the purchaser's own name. This authorization may only be revoked if the purchaser fails to properly perform its obligations to pay.
- VIII. Should any third party seize the goods to which title is retained, the purchaser shall be obligated to point out to the third party (or, in the event of resale, to its customer) that we are the owners of the goods and notify us without undue delay.



- IX. Without prejudice to any other rights we may have, we may withdraw from the contract without first setting a deadline for performance if the purchaser is in default of payment. The purchaser must immediately grant us or our agents access to the goods to which title is retained and surrender these goods. After a timely warning to this effect, we may use the goods to which title is retained otherwise with a view to achieving the settlement of our due claims against the purchaser.
- X. If the value of all security interests to which we are entitled exceeds the value of all secured claims by more than 20%, we will be obligated to release a corresponding portion of the security interests if so requested by the purchaser.
- 6. Adjustments – Withdrawal**
- I. If unforeseeable events, as defined in Sec. 3., subsections II and V above, materially affect the economic importance or contents of the delivery or have a significant impact on our business, the contract shall be appropriately adjusted, due regard being had to the principle of loyalty and good faith.
- II. If adjusting the contract is unreasonable from an economic point of view, we shall have the right to withdraw from the contract. If we wish to make use of this right to withdraw, we will so advise the purchaser without undue delay after becoming aware of the implications of the event.
- III. The preceding subsection II shall also apply if an extension of the delivery period was initially agreed upon with the purchaser. The right to withdraw from the contract shall be excluded if the reasons for the withdrawal were already identifiable at the time of conclusion of the contract. We will inform the purchaser without undue delay of the reasons for our withdrawal.
- IV. We shall additionally have the right to withdraw from the contract and take back our goods if
- a. the purchaser violates any of its obligations, in particular, if the purchaser defaults on payment and an – indispensable – reasonable deadline set by us for payment by the purchaser has expired to no avail or
 - b. we become aware of legitimate doubts about the purchaser's creditworthiness.
- V. In the event that we exercise a right to withdraw to which we are entitled, we will not be liable for damages.
- VI. Any consideration already paid shall be refunded without undue delay. Our obligation to surrender possession shall be limited to the payments and/or items received.
- 7. Prices and Payments**
- I. All our prices are in EURO, ex works, and exclusive of packaging. In addition, all our prices are exclusive of value added tax, which will be billed additionally at the statutory rate applicable from time to time.
- II. If we undertake to install or assemble the goods, the purchaser shall bear all necessary incidental costs, such as travel expenses, the cost of transporting tools and personal luggage, daily allowances, etc., in addition to the agreed-upon remuneration, unless otherwise agreed.
- III. With permanent obligations, the list price, catalog price, or daily price which is applicable on the day of the agreed-upon delivery shall be charged in the absence of an agreement concerning prices. This shall not affect any discounts or premiums granted.
- IV. All payments shall be made free of transaction charges to our designated bank account.
- V. If we have legitimate doubts about the purchaser's creditworthiness, we may demand that all outstanding receivables be paid immediately in cash. This shall also apply in the event that we already accepted bills or checks.
- VI. The purchaser may only make a set-off if its counterclaims are undisputed or have been finally established by declaratory judgment.
- 8. Defects of Quality**
- I. As a prerequisite for the purchaser's rights resulting from defects, the purchaser must examine the goods supplied upon receipt and inform us of defects, if any, in writing without undue delay, but no later than within two weeks of the receipt of the goods. Hidden defects must be reported to us in writing without undue delay after they have been discovered. When notifying us of defects, the purchaser must provide a written description of such defects.
- II. We will, at our option, repair defective parts free of charge or replace them with parts that are free of defects, provided the defect is due to circumstances which occurred before the passing of risk. In all other respects, Sec. 439 (3) German Civil Code shall apply.
- III. We assume no liability especially (but not only) in the following cases: natural wear and tear, unsuitable or improper use, incorrect installation or initial operation by the purchaser or a third party, incorrect or negligent treatment, improper maintenance, use of unsuitable operating materials, deficient construction work, unsuitable building ground, and chemical, electrical or electro-chemical influences, unless we are responsible for any such case.
- IV. Upon consultation with us, the purchaser must give us the time and opportunity required to carry out repairs or make a replacement delivery. In urgent cases where the operational safety is at risk or where the purchaser must prevent disproportionate damage – of which we must immediately be notified – the purchaser shall have the right to remedy the defect itself or have it remedied by a third party and demand from us reimbursement of the necessary expenses.
- V. Claims of the purchaser concerning expenses which are required for subsequent performance, in particular, the cost of transportation, travel expenses, and the cost of material and labor, shall be excluded to the extent they



rise as a result of the fact that the item delivered has subsequently been transferred to a place other than the purchaser's place of business, unless such transfer is in accordance with the agreed use. This shall apply correspondingly with respect to the extent of the purchaser's right of recourse against us in the cases stipulated in Sec. 478 (2) German Civil Code.

- VI. In the absence of a separate agreement stating otherwise, claims for defects shall be excluded if the actual quality of the goods supplied deviates only immaterially from the agreed-upon quality or if the usability of the goods is affected only immaterially, as well as in the case of software errors which cannot be reproduced.
- VII. Moreover, our liability shall be excluded if the purchaser or any third party carries out repairs improperly or if changes are made to the delivery item which have not been agreed to by us in advance.
- VIII. Payments may only be retained with respect to undisputed defects; the amount of the payments retained may not exceed twice the value of the (defective) parts.
- IX. If the purchaser reports defects and this is unjustified, we may demand to be reimbursed for any expenses incurred.

9. Defects of Title – Property Rights

- I. Unless otherwise agreed, we are obligated to deliver goods which are free of third-party copyrights and industrial property rights ("property rights") merely in the country where the place of delivery is located. If a third party asserts legitimate claims against the purchaser due to a property right infringement caused by goods that were delivered by us and have been used as agreed, we will be liable if the purchaser informs us of the claims asserted by the third party without undue delay in writing, refrains from acknowledging any infringement, and allows us to take control of the entire defense and negotiations concerning a settlement by compromise.
- II. If we are liable, we will, at our option and at our expense, procure the right to use the delivery items concerned, modify them so that they no longer infringe the third-party property right, or replace them. Sec. 439 (3) German Civil Code shall apply correspondingly.
- III. If the purchaser discontinues the use of the items concerned, the purchaser shall be obligated to inform the third party that such discontinuation does not constitute an acknowledgement of any property right infringement.
- IV. Claims shall be excluded if and to the extent that the purchaser is responsible for the property right infringement or such infringement was caused by special requirements of the purchaser, by any application that could not be foreseen by us, or by the purchaser modifying the items delivered or using them in combination with products not supplied by us.
- V. In all other respects, Sec. 8 above shall apply correspondingly.

10. Liability

Any claims for damages by the Customer for whatsoever cause in law are excluded. This does not apply where obligatory liability is given, e. g. under the German product liability law, or in cases of intent, gross negligence, for personal injury or the breach of essential contractual obligations.

11. Lapse of Time

All claims of the purchaser shall become time-barred within 12 months, irrespective of their legal basis. This does not apply if defective goods have been used for a building in accordance with their customary use and have resulted in the deficiency of this building, nor in the cases stipulated in Sec. 479 (1) German Civil Code. These provisions do not affect our unlimited liability for damage or losses resulting from breach of guarantee or from death, bodily injury, or damage to health, for willful misconduct and gross negligence, as well as for product defects.

12. Applicable Law and Place of Jurisdiction

- I. All legal relationships resulting from the business relationship shall be governed exclusively by the laws of the Federal Republic of Germany without regard to the United Nations Convention on Contracts for the International Sale of Goods (CISG).
- II. The exclusive place of jurisdiction for all rights and obligations resulting from the legal relationship shall be the Local Court (Amtsgericht) of Besigheim or, at our option, the Regional Court (Landgericht) of Heilbronn. We may additionally sue the purchaser before the local or regional court of competent jurisdiction over the purchaser's principal place of business.
- III. Should single provisions of these General Terms be or become invalid, this shall not affect the remaining provisions hereof.