



# Main Catalog 2012/2013

for specialists in automation and control technology

# Welcome to VIPA



## This is VIPA

- Specialists in automation and control systems.
- Developer in some to the most advanced products in the PLC field.
- Developer of some of the world's fastest hard PLCs of their class.
- Developer of technologies that are now the industry standard.
- Global Player with branches in 60 countries.
- Extremely customer oriented and flexible.



Wolfgang Seel | CEO

VIPA has traditionally been amongst the most innovative suppliers of memory-programmable controllers (PLCs) in the market and is growing worldwide, with double-digit growth rates. Therefore, VIPA belongs to the still young, but also exceptionally successful companies in the Automation market.

**Our success is based on five pillars:**

- High rate of innovation and quick decision making
- Various unique features
- A convincing cost-performance ratio
- Commitment and competence of our employees
- Cooperation with powerful partners

**Our aspiration:**

- Constantly continue to improve existing technologies, but also to introduce new and innovative trends in the market.
- Continuous flexible adaptation of our products to current market needs and to further increase our market acceptance.
- Continue to develop our personnel resources in sales, development, quality assurance and service in accordance with our revenue growth.
- Enter into cooperation agreements with powerful partners and to increase our market share through joint market cultivation.

To meet this aspiration, we consider it as our aim, also in the future, to improve what is established, to question, revise or develop completely from new.

Furthermore we want to make available to our partners and customers also in the future through continuous innovation and smart system maintenance unique technological features with which together we can gain new and satisfied system users.

With our highly motivated employees, we're working hard on improving our quality, service and the satisfaction of our customers and partners. Convince yourself of the possibilities that our automation solutions and systems offer, and discover how with us you can sustainably increase your competitiveness.

Strengthened by above-average growth, we are determined to continue our successful path in the future.

We look forward to cooperating with you!

A handwritten signature in black ink, appearing to read 'W. Seel'.

Wolfgang Seel  
CEO

# We speak your language ...

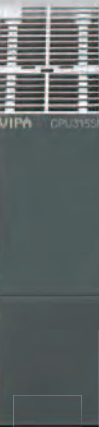

## SPEED7 ensures your lead

- a flexible automation platform
- and one of the fastest STEP7 PLC processors in the world!

SPEED7 technology offers developers a modular building block, with which a high-performance automation system can be developed in the shortest time on an open STEP7 architecture.

- SPEED7 ensures maximum speed with all applications and, for example, the highest clock rates.
- SPEED7 upgrades also older systems to a modern standard.
- SPEED7 processes vast amounts of data in real time.



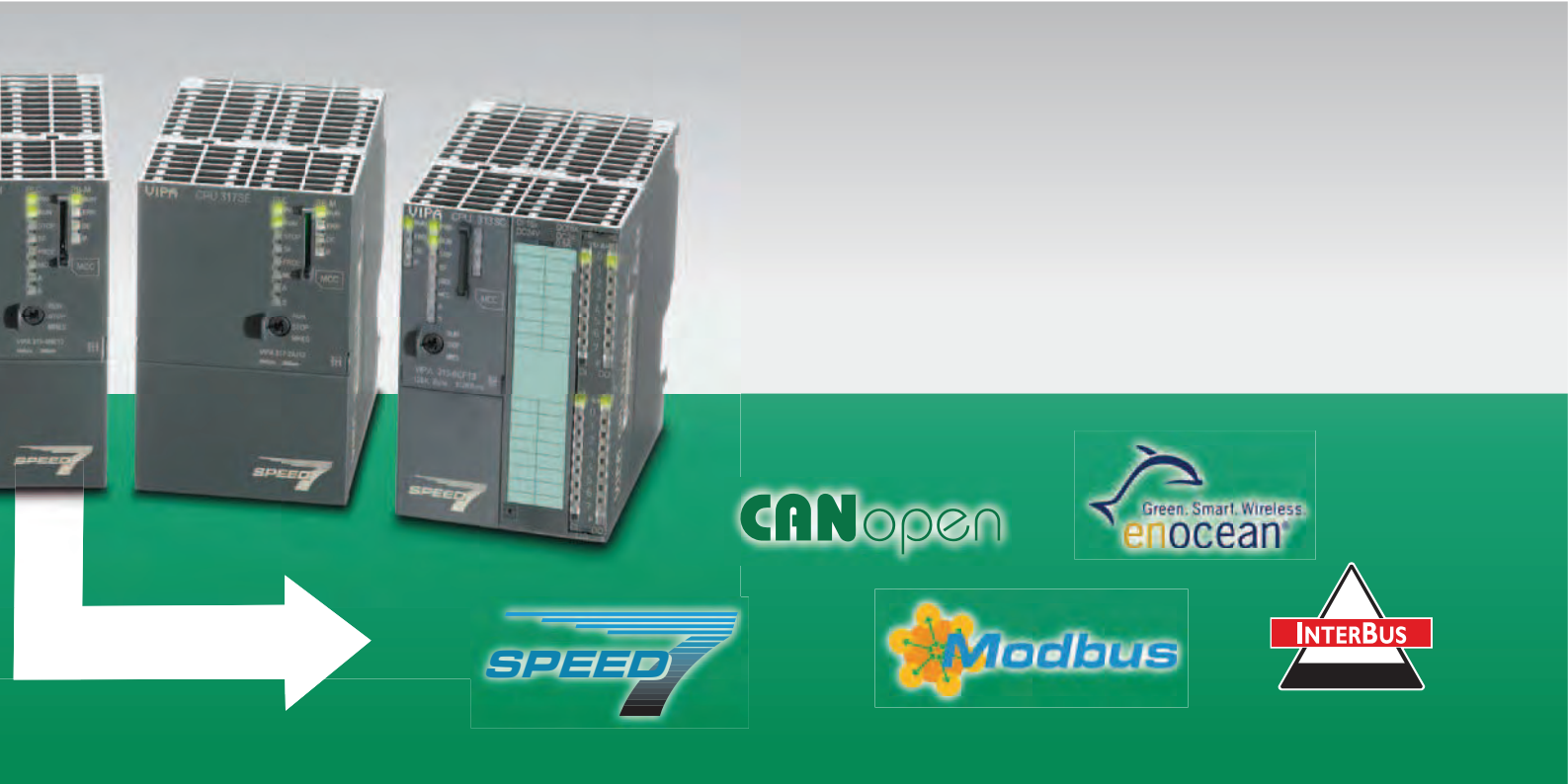

... and in future also that of almost all systems

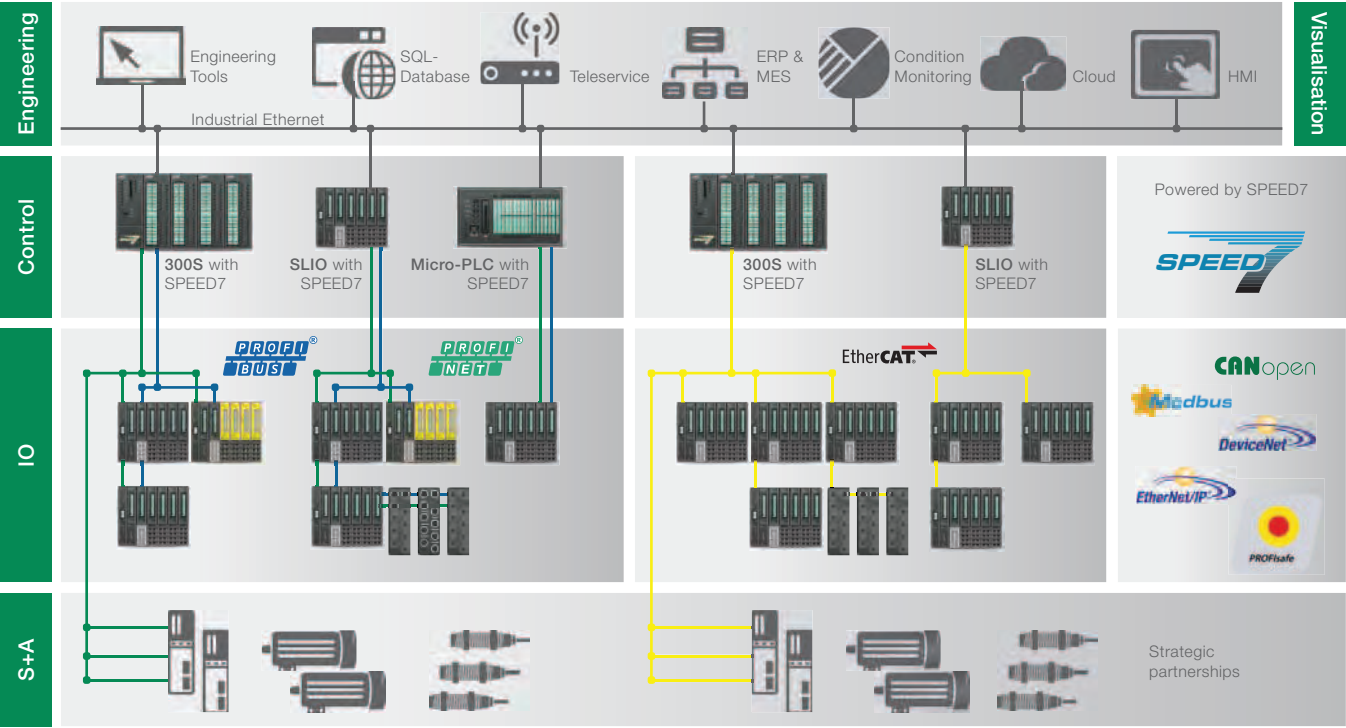

# System solutions



## Professional benefits for professional applications

- **Consistent standardization**  
All systems are programmable with VIPA WinPLC7 programming tool and/or with STEP7 from Siemens and in the future with the new "VIPA Suite".
- **Increase of productivity**  
Significant reduction in cycle times of user programs by SPEED7 technology with reduced power dissipation.
- **High efficiency**  
Above average basic features of the systems, integrated RJ45 Ethernet interface for PG/OP communication, optional integrated SPEED-Bus.
- **Absolute flexibility**  
Mixed operation for example with VIPA CPUs and Siemens assemblies possible.
- **Open communication possibilities**  
Supports internationally established communication standards like Ethernet, PROFIBUS, CANopen, EtherCAT, Modbus, EtherNet/IP, DeviceNet, Interbus, PROFINET and ASi.

**Automotive:**

An industry that needs solutions like on an assembly line. Ever increasing range of models, more and more complex technology, ever faster product cycles. Whoever wants to survive here, must be able to refine, expand, and accelerate his technology.

**Renewable energy:**

In principle every installation of a VIPA control system has its own energy policy - on starting up the efficiency increases right away, often the consumption of raw materials sinks and his conscience is eased.

**Building automation:**

Low energy is the goal, high performance is our way... Here our control systems are more intelligent than some specifications.

**Food & Beverage:**

Multi-purpose demands: Flash-freezing and autoclaving, vacuum packing and pressurized filling go on here. The whole thing under the toughest hygiene conditions and always under time pressure.

**Handling and storage technology:**

In order that the delivery rate never stands still, not only are tailor-made PLC systems designed at VIPA, but also precise, effective time schedules for their installation.

**Environment:**

Regardless of whether it's a question of renewable energy or water/sewage: The very strict requirements in terms of robustness, compact design and of energy consumption of the controllers can be excellently implemented with our automation technology.

**Packaging:**

The most important factor in this industry: Speed. Because many commodities are perishable, deliveries must arrive just in time and demand simply fluctuates.

**Water/Sewage:**

That a manufacturer of control engineering knows how a sewage plant works seems unusual. But this is typical VIPA. At VIPA no one turns his nose up when it comes to dealing with anaerobic digestion tanks, activated sludge and denitrification.



„If you don't know the destination, then you have no route.“ (Christian Morgenstern)

**100V** Control system for cost-sensitive and small applications



**200V** Modular control system for central and decentral applications



**300S** One of the fastest control systems programmable with STEP7



**500S** PC control system for complex tasks. And also one of the fastest control systems programmable with STEP7

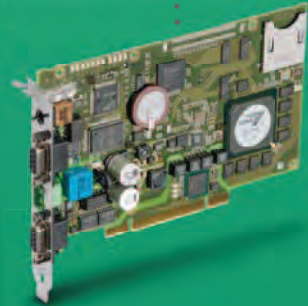

1985

VIPA



Foundation of profichip GmbH

Foundation of VIPA GmbH by Wolfgang Seel



Move to the new **headquarter** of VIPA and profichip in Herzogenaurach

**Operating / monitoring devices**

From two-line displays  
to touch panels

**Accessories**

enhancing, linking,  
optimizing

**SLIO** One of the most efficient  
and most modern decentral I/O  
systems in the world

**Software** for convenient  
programming and  
parameterization



2012

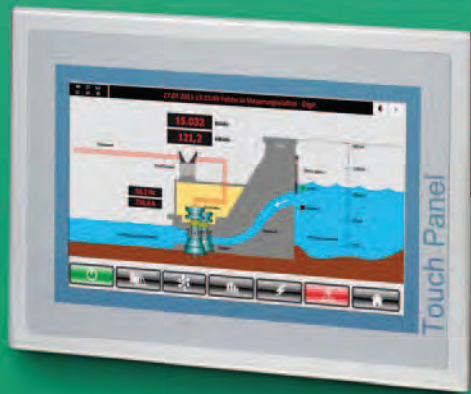

Winner of the innovation prize  
„Initiative Mittelstand 2007“  
for the SPEED7 technology

awarded with the **Jobstar** of  
Metropolitan Region Nuremberg

Winner of the industry prize  
„Industrie Preis 2008“ for  
the SPEED7 technology

Honoured as top  
innovator by **Top100**

## At a glance

System description SLIO	14
Clamp modules	16
Power modules	20
Signal modules digital	26
Signal modules analog	50
Communication processors	82
Function modules	88
Interface modules	98
SLIO accessories	106



# SLIO

the fine-granular I/O system

# System description SLIO

## Structure and Concept

SLIO stands for Slice I/O. The system is very compact and can be adapted piecemeal exactly to the requirements of the application.

The system is designed for decentralized automation tasks.

With the help of the power module (PM), color contrasted from the signal modules (SM) and functional modules (FM), these are supplied with power and separate potential groups can be defined as required. The terminal module (TM) combines clamp, seating for the electronic module (EM) and mechanical bus connector. The electronic modules are connected to the terminal module in a secure sliding mechanism. In the case of service, only the electronic module is replaced by simply pulling out of the terminal module – wiring and mounting remain on the 35 mm profile rail. The step-formed spring-type terminals on the terminal module enable a quick, clear and secure wiring. Through integrated status LEDs and the label strip on the front a channel-specific, unambiguous allocation, and readability of the channel conditions of the electronic module is ensured.

All interface modules (IM) for PROFIBUS-DP, CANopen, PROFINET, EtherCAT, DeviceNet and Modbus/TCP support up to 64 electronic modules.

The space-saving assembly size allows use in any automation environment.

Assembly is very easy: First the terminal modules are connected, then the electronic modules are inserted into the slot designated for the terminal module until the connection between both module parts is established by an audible click.

SLIO is one of the most highly efficient decentral systems worldwide and is evolving daily.



### Performance and Application

SLIO is designed for large decentralized automation tasks in the manufacturing and process industries. SLIO expands key solutions and is integrated with the help of the device master files into existing fieldbus infrastructure. Through the new backplane bus concept the interface modules (fieldbus slave) in SLIO enable very short response times for signal processing.

### Functions

A variety of signal modules are available for the connection of sensors and actuators for acquiring digital and analog signals to and from the process.

For positioning, path measurement, counting tasks and other functions further functional modules are continuously being developed.

### Communication

SLIO includes interface modules (fieldbus slave modules) with different fieldbus protocols by which the system, manufacturer-independent, can be integrated into most automation concepts.

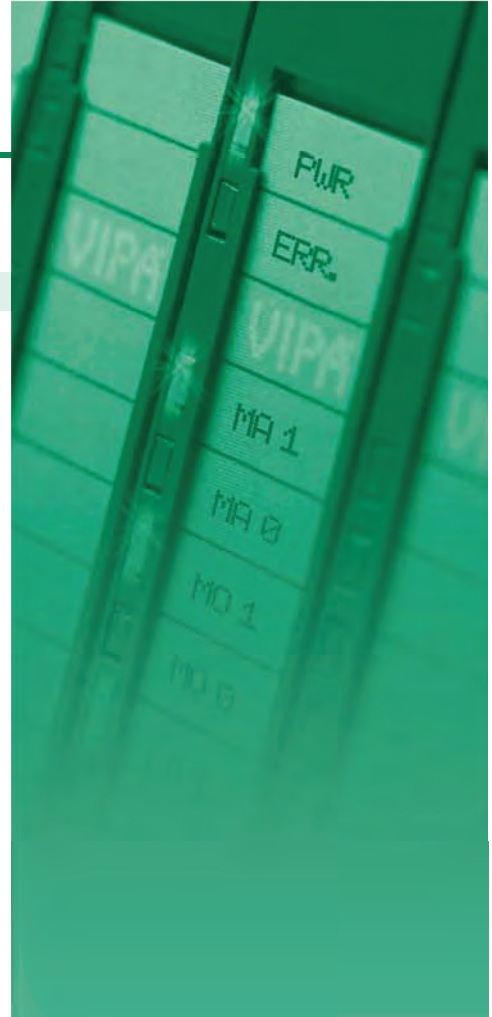

# Clamp modules



## Assembly and function

Clamp modules are passive modules for 2- or 3-wire installations, whose contacts are vertical electrical connected internal. Within the module the backplane bus feed-through. The module does not have any module identification, but is considered at the maximum number of the modules.

Through the application of the clamp modules, distributors for power supply could be realized easily and enables so the connection of active supplied sensors like proximity switch. The wiring is done via timesaving and secure cage clamp technique.

The clamp modules are fixed on the mounting surface by means of a 35mm DIN rail.

### Features

- › Maintenance-free cage clamp technique
- › Backplane bus feed-through
- › Max. terminal voltage 10A
- › Potential separation 500 Veff (field voltage to bus)
- › Mounting on a 35mm DIN rail
- › 24 month guarantee



# Overview

Order no.	Name/Description	Page
Clamp modules		
001-1BA00	<b>CM 001 - Potential distributor module</b> › 8xDC 24 V clamps	<b>18</b>
001-1BA10	<b>CM 001 - Potential distributor module</b> › 8xDC 0 V clamps	<b>18</b>
001-1BA20	<b>CM 001 - Potential distributor module</b> › 4xDC 24 V, 4xDC 0 V clamps	<b>18</b>

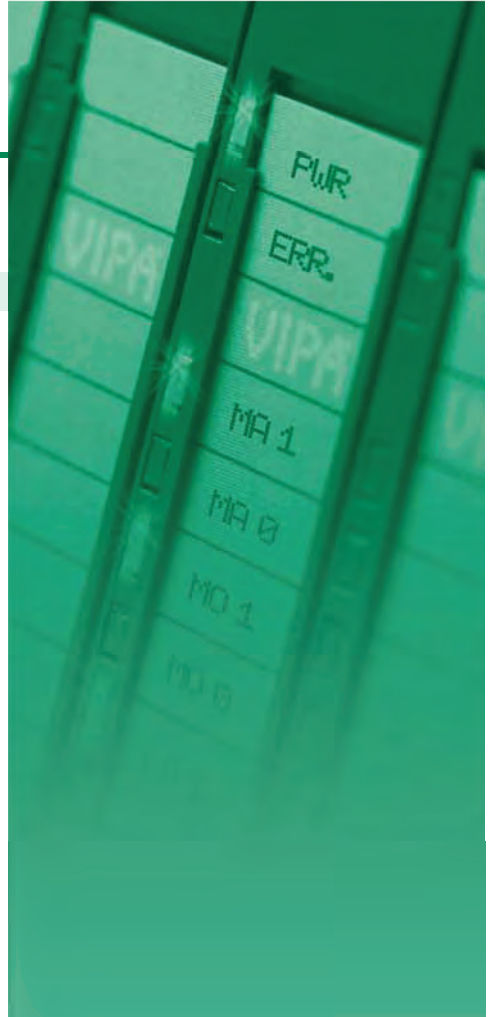

# Clamp modules

Clamp modules   Clamp modules						
001-1BA00						
001-1BA10						
001-1BA20						

Order number	001-1BA00	001-1BA10	001-1BA20	
Figure				
Type	CM 001	CM 001	CM 001	
Module ID	-	-	-	
<b>General information</b>				
Note	-	-	-	
Features	▸ 8xDC 24 V clamps	▸ 8xDC 0 V clamps	▸ 4xDC 24 V, 4xDC 0 V clamps	
<b>Clamp parameter</b>				
Terminal voltage max.	DC 30 V	DC 0 V	DC 30 V	
Terminal current max.	10 A	10 A	10 A	
<b>Housing</b>				
Material	PPE / PPE GF10	PPE / PPE GF10	PPE / PPE GF10	
Mounting	Profile rail 35 mm	Profile rail 35 mm	Profile rail 35 mm	
<b>Mechanical data</b>				
Dimensions (WxHxD)	12.9 mm x 109 mm x 52.5 mm	12.9 mm x 109 mm x 52.5 mm	12.9 mm x 109 mm x 52.5 mm	
Weight	50 g	50 g	50 g	
<b>Environmental conditions</b>				
Operating temperature	0 °C to 60 °C	0 °C to 60 °C	0 °C to 60 °C	
Storage temperature	-25 °C to 70 °C	-25 °C to 70 °C	-25 °C to 70 °C	
<b>Certifications</b>				
UL508 certification	yes	yes	yes	

# Connections, Interfaces

## Clamp modules | Clamp modules

001-1BA00  
001-1BA10  
001-1BA20

### 001-1BA00

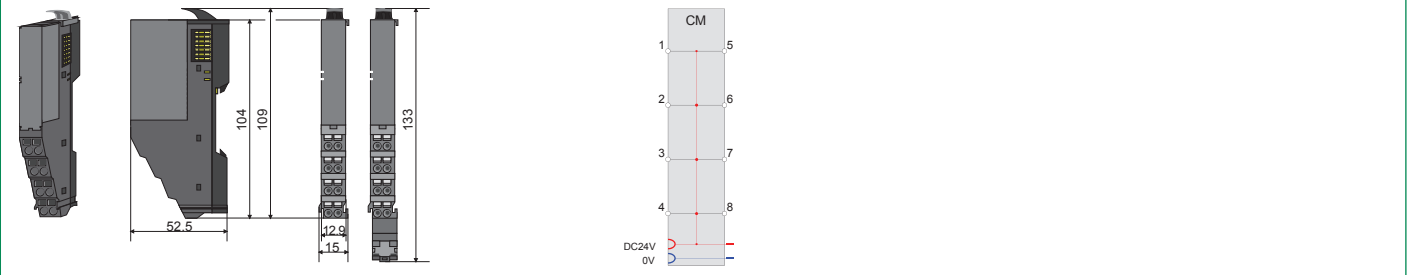

### 001-1BA10

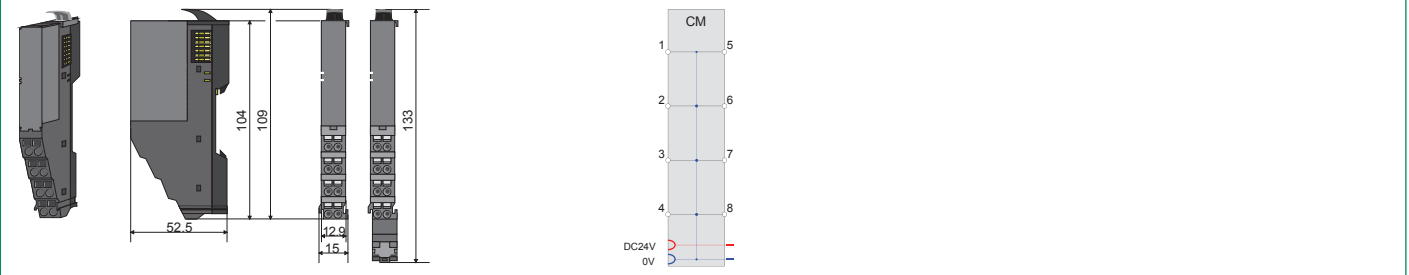

### 001-1BA20

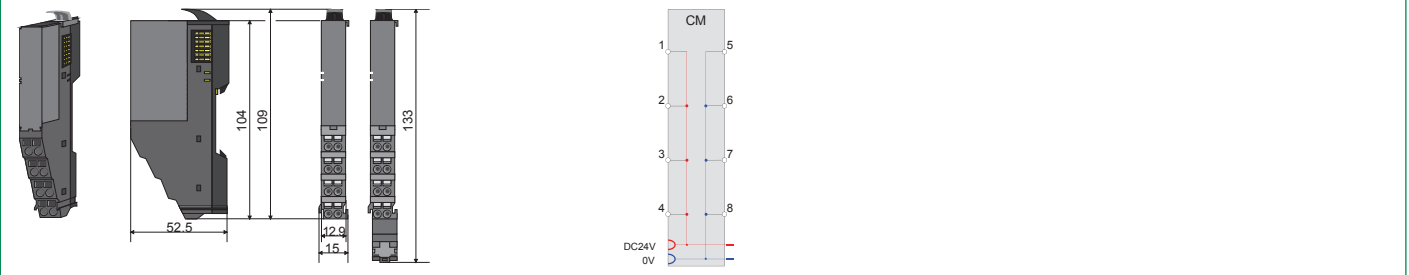

# Power modules

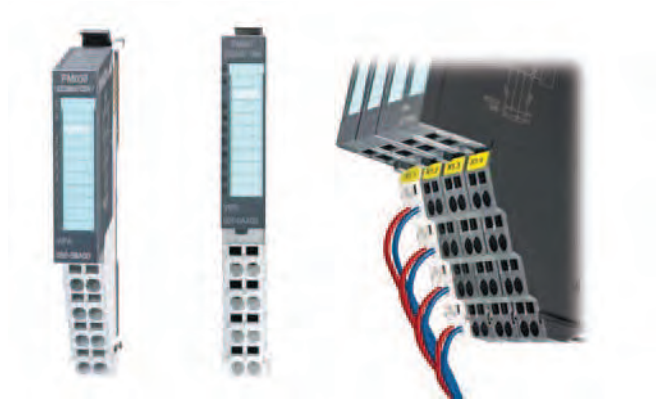

## Structure and Function

In the system SLIO the power supply is provided via power modules.

Both the bus interface as well as the electronics of the connected peripheral modules are supplied with power via the power module (PM) integrated in interface module (IM). The DC 24 V load power supply for the connected peripheral modules is provided via a further connection in the PM.

With the help of color-contrasted power modules within the system further potential areas for the DC 24 V load power supply can be defined.

The two-component design allows for the easiest of service by separating the electronics from the terminal module.

### Characteristics

- › Power supply of the sensor/actuator-level
- › Nominal input voltage DC 24 V
- › Output current max. 10 A
- › Isolation from potential groups
- › Front integrated status LEDs
- › Mounting security by reverse polarity and overvoltage protection
- › 24 months warranty

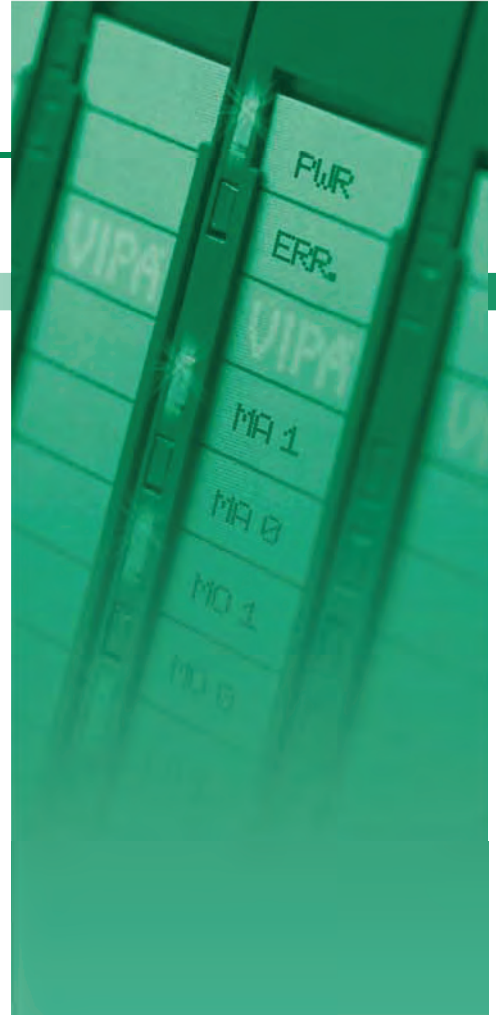

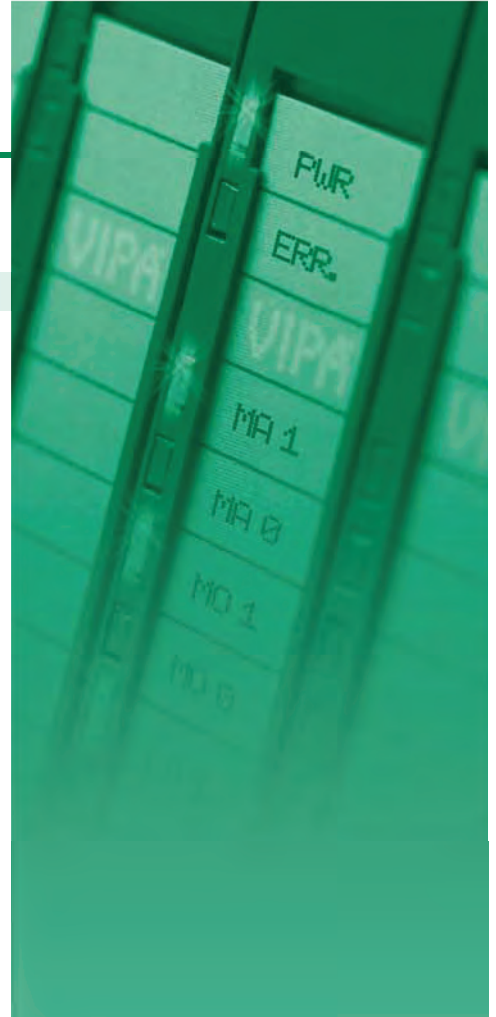

# Overview

Order no.	Name/Description	Page
Power modules		
007-1AB00	<b>PM 007 - Power module</b> ▶ Power supply DC 24 V, 10 A ▶ Reverse polarity protection ▶ Overvoltage protection	22
007-1AB10	<b>PM 007 - Power module</b> ▶ Power supply DC 24 V, 4 A ▶ Power supply DC 24 V for bus supply 5 V, 2 A ▶ Reverse polarity protection ▶ Overvoltage protection	22



# Power modules

Power modules   Power modules						
007-1AB00 007-1AB10						

Order number	007-1AB00	007-1AB10		
Figure				
Type	PM 007	PM 007		
Module ID	-	-		
<b>General information</b>				
Note	-	-		
Features	<ul style="list-style-type: none"> <li>▸ Power supply DC 24 V, 10 A</li> <li>▸ Reverse polarity protection</li> <li>▸ Overvoltage protection</li> </ul>	<ul style="list-style-type: none"> <li>▸ Power supply DC 24 V, 4 A</li> <li>▸ Power supply DC 24 V for bus supply 5 V, 2 A</li> <li>▸ Reverse polarity protection</li> <li>▸ Overvoltage protection</li> </ul>		
<b>Technical data power supply</b>				
Input voltage (rated value)	DC 24 V	DC 24 V		
Input voltage (permitted range)	DC 20.4...28.8 V	DC 20.4...28.8 V		
Mains frequency (rated value)	-	-		
Mains frequency (permitted range)	-	-		
Input voltage (at 120 V)	-	-		
Input voltage (at 230 V)	-	-		
Inrush current	-	-		
Power consumption	-	-		
Output voltage (rated value)	24 V	24 V		
Output current (rated value)	10 A	4 A		
Power supply parallel switchable	-	-		
Reverse polarity protection	yes	yes		
Overvoltage protection	36 V	36 V		
Ripple of output voltage (max.)	-	-		
Efficiency	-	89 %		
Power loss	-	1.4 W		
<b>Status information, alarms, diagnostics</b>				
Status display	yes	yes		
Interrupts	no	no		
Process alarm	no	no		
Diagnostic interrupt	no	no		
Diagnostic functions	no	no		
Diagnostics information read-out	none	none		
Supply voltage display	green LED	green LED		
Group error display	red LED	red LED		
Channel error display	none	none		
<b>Housing</b>				
Material	PPE / PPE GF10	PPE / PPE GF10		
Mounting	Profile rail 35 mm	Profile rail 35 mm		

SLIO  
 100V  
 200V  
 300S  
 500S  
 HMI  
 Software  
 Accessories  
 Appendix

Power modules   Power modules						
007-1AB00 007-1AB10						

Order number	007-1AB00	007-1AB10		
<b>Mechanical data</b>				
Dimensions (WxHxD)	12.9 mm x 109 mm x 76.5 mm	12.9 mm x 109 mm x 76.5 mm		
Weight	60 g	75 g		
<b>Environmental conditions</b>				
Operating temperature	0 °C to 60 °C	0 °C to 60 °C		
Storage temperature	-25 °C to 70 °C	-25 °C to 70 °C		
<b>Certifications</b>				
UL508 certification	yes	yes		

# Connections, Interfaces

Power modules   Power modules						
007-1AB00						
007-1AB10						

**007-1AB00**

**007-1AB10**



# Signal modules digital



## Structure and Function

Signal modules (SM) to connect sensors and actuators are the interfaces of the system to the process. Digital signal modules acquire the binary control signals to and from the process level.

A variety of different digital signal modules provides exactly the I/O modules, which are required for each task. The digital modules differ in the number of channels, voltage and current ranges, isolation, and diagnostic and alarm capability.

Each signal module consists of a terminal and an electronic module.

The terminal module (TM) contains the receptacle for the electronic module (EM), the backplane connectors and contacts for the distribution of the load power supply electronics, the modular connection to DC 24 V load power supply and the staircase-shaped terminal block for wiring.

Furthermore the terminal module processes a locking system for fixing to a profile rail. The SLIO system can also be constructed "block by block" outside the cabinet and later assembled as a complete system in the control cabinet.

The functionality of the signal module is defined via the electronics module that is connected by a secure sliding mechanism to the terminal module.

During service the defective electronic module can be replaced without detaching the wiring.

### Characteristics

- › Electrically isolated digital inputs and outputs to the backplane bus
- › 2, 4 or 8 channel
- › Various modules, suitable for switches and proximity switches as well as for measuring transducers
- › Direct mapping and readability of the channel conditions via status LEDs
- › Safe and time-saving installation by the terminal assignment mounted on the module
- › When changing the module equipment identification (BMK) is retained on the TM
- › Individual single-channel lettering on insertion strip
- › 24 month warranty



# Overview

Order no.	Name/Description	Page
Digital input modules		
021-1BB00	<b>SM 021 - Digital input</b> ‣ 2 inputs	29
021-1BB10	<b>SM 021 - Digital input</b> ‣ 2 fast inputs ‣ Input filter time delay parameterizable 2 μs...4 ms	29
021-1BB50	<b>SM 021 - Digital input</b> ‣ 2 inputs ‣ Active low input	29
021-1BB70	<b>SM 021 - Digital input</b> ‣ 2 inputs ‣ Time stamp	29
021-1BD00	<b>SM 021 - Digital input</b> ‣ 4 inputs	32
021-1BD10	<b>SM 021 - Digital input</b> ‣ 4 fast inputs ‣ Input filter time delay parameterizable 2 μs...4 ms	32
021-1BD40	<b>SM 021 - Digital input</b> ‣ 4 inputs ‣ Connect 2/3-wire	32
021-1BD50	<b>SM 021 - Digital input</b> ‣ 4 inputs ‣ Active low input	32
021-1BD70	<b>SM 021 - Digital input</b> ‣ 4 inputs ‣ Time stamp	35
021-1BF00	<b>SM 021 - Digital input</b> ‣ 8 inputs	35
021-1BF50	<b>SM 021 - Digital input</b> ‣ 8 inputs ‣ Active low input	35
021-1SD00	<b>SM 021 - Digital input</b> ‣ 4 inputs ‣ Safety	35
Digital output modules		
022-1BB00	<b>SM 022 - Digital output</b> ‣ 2 outputs ‣ Output current 0.5 A	38
022-1BB20	<b>SM 022 - Digital output</b> ‣ 2 outputs ‣ Output current 2 A	38
022-1BB50	<b>SM 022 - Digital output</b> ‣ 2 Low-Side outputs ‣ Output current 0.5 A	38
022-1BB70	<b>SM 022 - Digital output</b> ‣ 2 outputs ‣ Time stamp ‣ Output current 0.5 A	38
022-1BB90	<b>SM 022 - Digital output</b> ‣ 2 outputs ‣ PWM	41
022-1BD00	<b>SM 022 - Digital output</b> ‣ 4 outputs ‣ Output current 0.5 A	41
022-1BD20	<b>SM 022 - Digital output</b> ‣ 4 outputs ‣ Output current 2 A	41
022-1BD50	<b>SM 022 - Digital output</b> ‣ 4 Low-Side outputs ‣ Output current 0.5 A	41
022-1BD70	<b>SM 022 - Digital output</b> ‣ 4 outputs ‣ Time stamp ‣ Output current 0.5 A	44
022-1BF00	<b>SM 022 - Digital output</b> ‣ 8 outputs ‣ Output current 0.5 A	44



# Overview



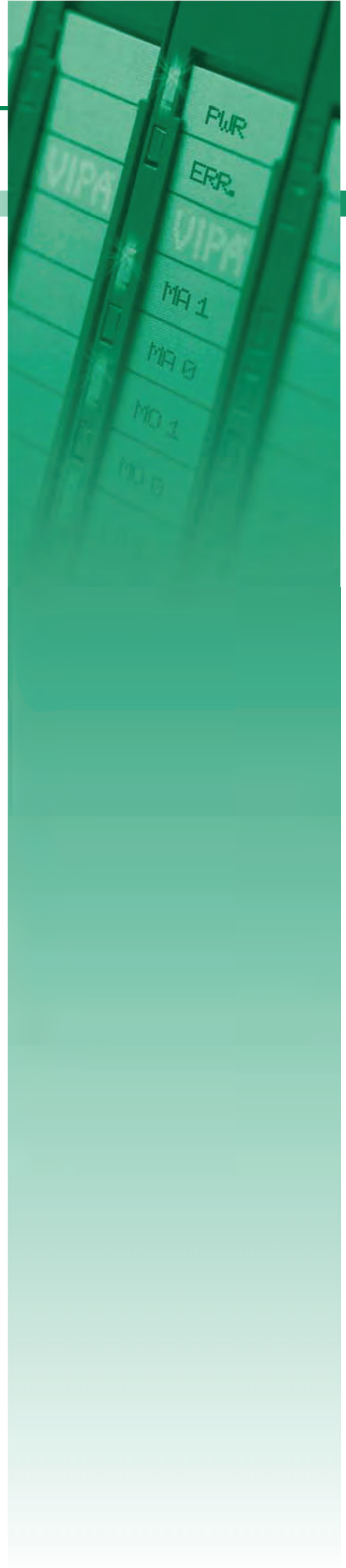

Order no.	Name/Description	Page
022-1BF50	<b>SM 022 - Digital output</b> › 8 Low-Side outputs › Output current 0.5 A	44
022-1HB10	<b>SM 022 - Digital output</b> › 2 relay outputs › DC 30 V/ AC 230 V › Output current 3 A	44
022-1SD00	<b>SM 022 - Digital output</b> › 4 outputs › Safety › Output current 0.5 A	47



# Digital input modules

## Signal modules digital | Digital input modules

021-1BB00	021-1BD00	021-1BD70			
021-1BB10	021-1BD10	021-1BF00			
021-1BB50	021-1BD40	021-1BF50			
021-1BB70	021-1BD50	021-1SD00			

Order number	021-1BB00	021-1BB10	021-1BB50	021-1BB70
Figure				
Type	SM 021	SM 021	SM 021	SM 021
Module ID	0001 9F82	000A 1F02	0002 9F82	0F01 47C1
<b>General information</b>				
Note	-	-	-	-
Features	<ul style="list-style-type: none"> <li>▸ 2 inputs</li> </ul>	<ul style="list-style-type: none"> <li>▸ 2 fast inputs</li> <li>▸ Input filter time delay parameterizable 2 μs...4 ms</li> </ul>	<ul style="list-style-type: none"> <li>▸ 2 inputs</li> <li>▸ Active low input</li> </ul>	<ul style="list-style-type: none"> <li>▸ 2 inputs</li> <li>▸ Time stamp</li> </ul>
<b>Current consumption/power loss</b>				
Current consumption from backplane bus	55 mA	95 mA	60 mA	85 mA
Power loss	0.5 W	0.9 W	0.5 W	0.9 W
<b>Technical data digital inputs</b>				
Number of inputs	2	2	2	2
Cable length, shielded	1000 m	1000 m	1000 m	1000 m
Cable length, unshielded	600 m	600 m	600 m	600 m
Rated load voltage	-	DC 20.4...28.8 V	-	DC 24 V
Current consumption from load voltage L+ (without load)	-	12 mA	-	10 mA
Rated value	DC 20.4...28.8 V	DC 20.4...28.8 V	DC 20.4...28.8 V	DC 20.4...28.8 V
Input voltage for signal "0"	DC 0...5 V	DC 0...5 V	DC 15...28.8 V	DC 0...5 V
Input voltage for signal "1"	DC 15...28.8 V	DC 15...28.8 V	DC 0...5 V	DC 15...28.8 V
Input voltage hysteresis	-	-	-	-
Frequency range	-	-	-	-
Input resistance	-	-	-	-
Input current for signal "1"	3 mA	3 mA	3 mA	3 mA
Connection of Two-Wire-BERs possible	✓	✓	✓	✓
Max. permissible BERO quiescent current	0.5 mA	0.5 mA	0.5 mA	0.5 mA
Input delay of "0" to "1"	3 ms	parameterizable 2 μs - 3ms	3 ms	parameterizable 2 μs - 3ms
Input delay of "1" to "0"	3 ms	parameterizable 2 μs - 3ms	3 ms	parameterizable 2 μs - 3ms
Number of simultaneously utilizable inputs horizontal configuration	2	2	2	2
Number of simultaneously utilizable inputs vertical configuration	2	2	2	2
Input characteristic curve	IEC 61131, type 1	IEC 61131, type 1	-	IEC 61131, type 1
Initial data size	2 Bit	2 Bit	2 Bit	60 Byte
<b>Status information, alarms, diagnostics</b>				
Status display	green LED per channel	green LED per channel	green LED per channel	green LED per channel
Interrupts	no	yes, parameterizable	no	no
Process alarm	no	yes, parameterizable	no	no
Diagnostic interrupt	no	yes, parameterizable	no	no

Signal modules digital   Digital input modules						
021-1BB00	021-1BD00	021-1BD70				
021-1BB10	021-1BD10	021-1BF00				
021-1BB50	021-1BD40	021-1BF50				
021-1BB70	021-1BD50	021-1SD00				

Order number	021-1BB00	021-1BB10	021-1BB50	021-1BB70
Diagnostic functions	no	yes	no	no
Diagnostics information read-out	none	possible	none	possible
Module state	green LED	green LED	green LED	green LED
Module error display	red LED	red LED	red LED	red LED
Channel error display	none	none	none	none
<b>Isolation</b>				
Between channels	-	-	-	-
Between channels of groups to	-	-	-	-
Between channels and backplane bus	✓	✓	✓	✓
Insulation tested with	DC 500 V	DC 500 V	DC 500 V	DC 500 V
<b>Safety</b>				
Safety protocol	-	-	-	-
Safety requirements	-	-	-	-
Secure user address	-	-	-	-
Watchdog	-	-	-	-
Two channels	-	-	-	-
Test pulse outputs	-	-	-	-
<b>Datasizes</b>				
Input bytes	1	1	1	20 / 60
Output bytes	0	0	0	0
Parameter bytes	0	9	0	10
Diagnostic bytes	0	20	0	20
<b>Housing</b>				
Material	PPE / PPE GF10	PPE / PPE GF10	PPE / PPE GF10	PPE / PPE GF10
Mounting	Profile rail 35 mm	Profile rail 35 mm	Profile rail 35 mm	Profile rail 35 mm
<b>Mechanical data</b>				
Dimensions (WxHxD)	12.9 mm x 109 mm x 76.5 mm	12.9 mm x 109 mm x 76.5 mm	12.9 mm x 109 mm x 76.5 mm	12.9 mm x 109 mm x 76.5 mm
Weight	60 g	60 g	60 g	60 g
<b>Environmental conditions</b>				
Operating temperature	0 °C to 60 °C	0 °C to 60 °C	0 °C to 60 °C	0 °C to 60 °C
Storage temperature	-25 °C to 70 °C	-25 °C to 70 °C	-25 °C to 70 °C	-25 °C to 70 °C
<b>Certifications</b>				
UL508 certification	yes	yes	yes	yes

# Connections, Interfaces

Signal modules digital | Digital input modules

021-1BB00	021-1BD00	021-1BD70			
021-1BB10	021-1BD10	021-1BF00			
021-1BB50	021-1BD40	021-1BF50			
021-1BB70	021-1BD50	021-1SD00			

021-1BB00

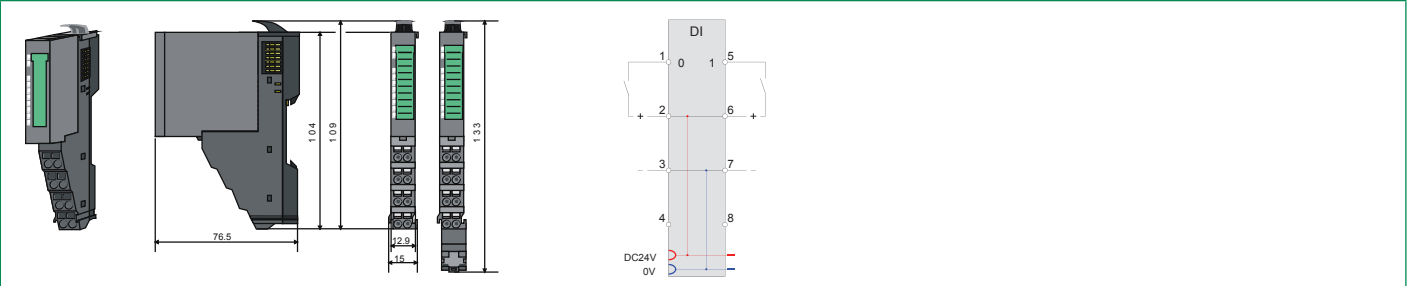

021-1BB10

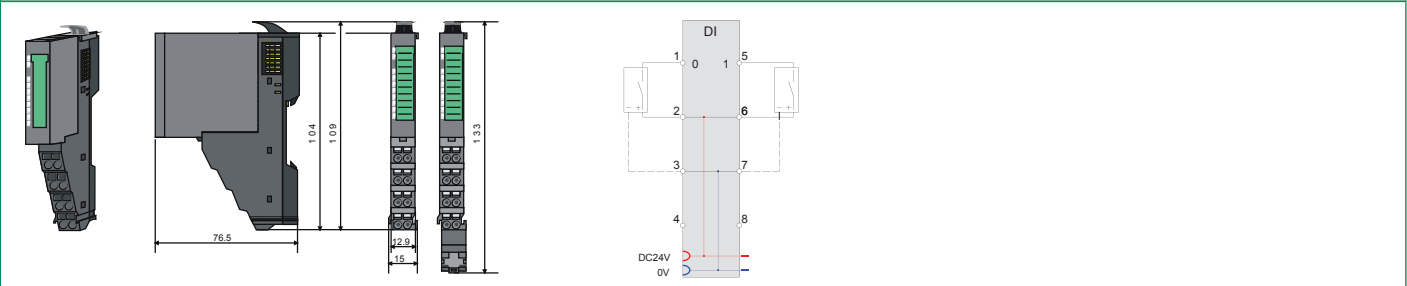

021-1BB50

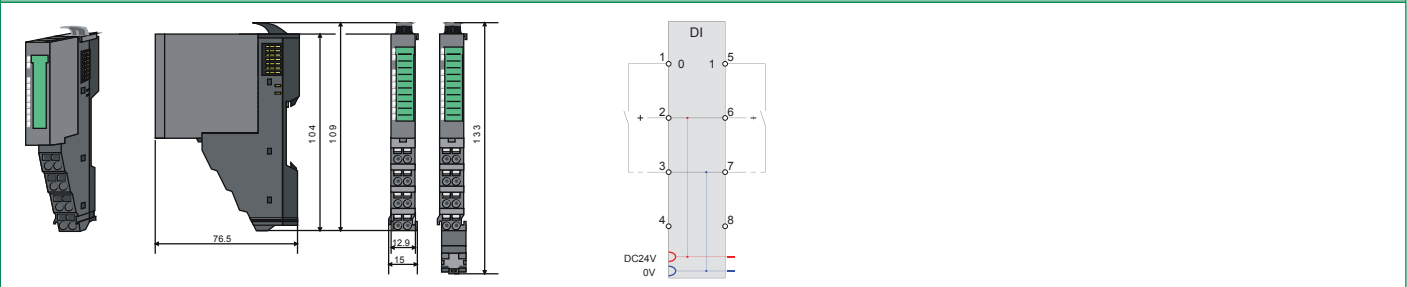



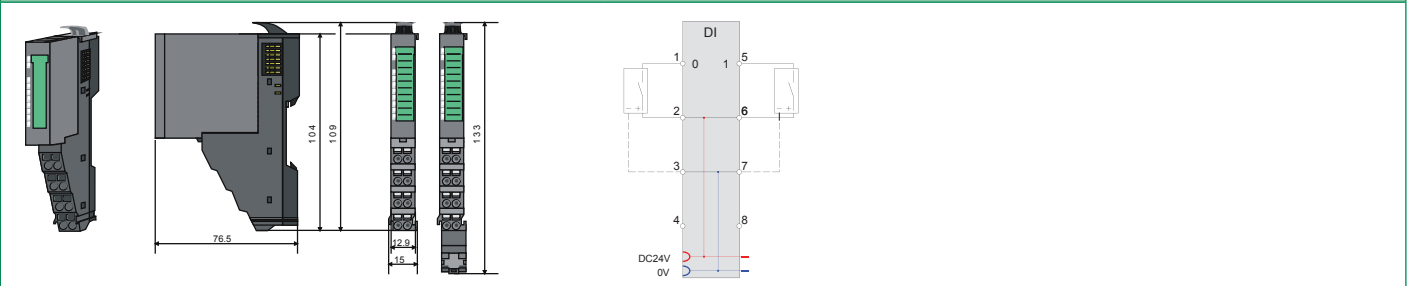

021-1BB70



# Digital input modules

Signal modules digital   Digital input modules					
021-1BB00	021-1BD00	021-1BD70			
021-1BB10	021-1BD10	021-1BF00			
021-1BB50	021-1BD40	021-1BF50			
021-1BB70	021-1BD50	021-1SD00			

Order number	021-1BD00	021-1BD10	021-1BD40	021-1BD50
Figure				
Type	SM 021	SM 021	SM 021	SM 021
Module ID	0003 9F84	0009 1F04	0008 9F84	0004 9F84
<b>General information</b>				
Note	-	-	-	-
Features	<ul style="list-style-type: none"> <li>▸ 4 inputs</li> </ul>	<ul style="list-style-type: none"> <li>▸ 4 fast inputs</li> <li>▸ Input filter time delay parameterizable 2 μs...4 ms</li> </ul>	<ul style="list-style-type: none"> <li>▸ 4 inputs</li> <li>▸ Connect 2/3-wire</li> </ul>	<ul style="list-style-type: none"> <li>▸ 4 inputs</li> <li>▸ Active low input</li> </ul>
<b>Current consumption/power loss</b>				
Current consumption from backplane bus	55 mA	95 mA	55 mA	65 mA
Power loss	0.6 W	0.95 W	0.6 W	0.6 W
<b>Technical data digital inputs</b>				
Number of inputs	4	4	4	4
Cable length, shielded	1000 m	1000 m	1000 m	1000 m
Cable length, unshielded	600 m	600 m	600 m	600 m
Rated load voltage	-	DC 20.4...28.8 V	-	-
Current consumption from load voltage L+ (without load)	-	15 mA	-	-
Rated value	DC 20.4...28.8 V	DC 20.4...28.8 V	DC 20.4...28.8 V	DC 20.4...28.8 V
Input voltage for signal "0"	DC 0...5 V	DC 0...5 V	DC 0...5 V	DC 15...28.8 V
Input voltage for signal "1"	DC 15...28.8 V	DC 15...28.8 V	DC 15...28.8 V	DC 0...5 V
Input voltage hysteresis	-	-	-	-
Frequency range	-	-	-	-
Input resistance	-	-	-	-
Input current for signal "1"	3 mA	3 mA	3 mA	3 mA
Connection of Two-Wire-BEROs possible	✓	✓	✓	✓
Max. permissible BERO quiescent current	0.5 mA	0.5 mA	0.5 mA	0.5 mA
Input delay of "0" to "1"	3 ms	parameterizable 2 μs - 3ms	3 ms	3 ms
Input delay of "1" to "0"	3 ms	parameterizable 2 μs - 3ms	3 ms	3 ms
Number of simultaneously utilizable inputs horizontal configuration	4	4	4	4
Number of simultaneously utilizable inputs vertical configuration	4	4	4	4
Input characteristic curve	IEC 61131, type 1	IEC 61131, type 1	IEC 61131, type 1	-
Initial data size	4 Bit	4 Bit	4 Bit	4 Bit
<b>Status information, alarms, diagnostics</b>				
Status display	green LED per channel	green LED per channel	green LED per channel	green LED per channel
Interrupts	no	yes, parameterizable	no	no
Process alarm	no	yes, parameterizable	no	no
Diagnostic interrupt	no	yes, parameterizable	no	no

Signal modules digital | Digital input modules

021-1BB00	021-1BD00	021-1BD70				
021-1BB10	021-1BD10	021-1BF00				
021-1BB50	021-1BD40	021-1BF50				
021-1BB70	021-1BD50	021-1SD00				

Order number	021-1BD00	021-1BD10	021-1BD40	021-1BD50
Diagnostic functions	no	yes	no	no
Diagnostics information read-out	none	possible	none	none
Module state	green LED	green LED	green LED	green LED
Module error display	red LED	red LED	red LED	red LED
Channel error display	none	none	none	none
<b>Isolation</b>				
Between channels	-	-	-	-
Between channels of groups to	-	-	-	-
Between channels and backplane bus	✓	✓	✓	✓
Insulation tested with	DC 500 V	DC 500 V	DC 500 V	DC 500 V
<b>Safety</b>				
Safety protocol	-	-	-	-
Safety requirements	-	-	-	-
Secure user address	-	-	-	-
Watchdog	-	-	-	-
Two channels	-	-	-	-
Test pulse outputs	-	-	-	-
<b>Datasizes</b>				
Input bytes	1	1	1	1
Output bytes	0	0	0	0
Parameter bytes	0	11	0	0
Diagnostic bytes	0	20	0	0
<b>Housing</b>				
Material	PPE / PPE GF10	PPE / PPE GF10	PPE / PPE GF10	PPE / PPE GF10
Mounting	Profile rail 35 mm	Profile rail 35 mm	Profile rail 35 mm	Profile rail 35 mm
<b>Mechanical data</b>				
Dimensions (WxHxD)	12.9 mm x 109 mm x 76.5 mm	12.9 mm x 109 mm x 76.5 mm	12.9 mm x 109 mm x 76.5 mm	12.9 mm x 109 mm x 76.5 mm
Weight	60 g	60 g	60 g	60 g
<b>Environmental conditions</b>				
Operating temperature	0 °C to 60 °C	0 °C to 60 °C	0 °C to 60 °C	0 °C to 60 °C
Storage temperature	-25 °C to 70 °C	-25 °C to 70 °C	-25 °C to 70 °C	-25 °C to 70 °C
<b>Certifications</b>				
UL508 certification	yes	yes	yes	yes

# Connections, Interfaces

Signal modules digital   Digital input modules					
021-1BB00	021-1BD00	021-1BD70			
021-1BB10	021-1BD10	021-1BF00			
021-1BB50	021-1BD40	021-1BF50			
021-1BB70	021-1BD50	021-1SD00			

**021-1BD00**

Technical drawing of the 021-1BD00 module showing front, side, and rear views with dimensions: 76.5, 10.4, 10.9, 12.9, 1.5, and 13.3. A terminal block diagram shows 8 DI channels with connections for DC24V and 0V.

**021-1BD10**

Technical drawing of the 021-1BD10 module showing front, side, and rear views with dimensions: 76.5, 10.4, 10.9, 12.9, 1.5, and 13.3. A terminal block diagram shows 8 DI channels with connections for DC24V and 0V.

**021-1BD40**

Technical drawing of the 021-1BD40 module showing front, side, and rear views with dimensions: 76.5, 10.4, 10.9, 12.9, 1.5, and 13.3. A terminal block diagram shows 8 DI channels with connections for DC24V and 0V.





**021-1BD50**

Technical drawing of the 021-1BD50 module showing front, side, and rear views with dimensions: 76.5, 10.4, 10.9, 12.9, 1.5, and 13.3. A terminal block diagram shows 8 DI channels with connections for DC24V and 0V.

# Digital input modules

## Signal modules digital | Digital input modules

021-1BB00	021-1BD00	021-1BD70			
021-1BB10	021-1BD10	021-1BF00			
021-1BB50	021-1BD40	021-1BF50			
021-1BB70	021-1BD50	021-1SD00			

Order number	021-1BD70	021-1BF00	021-1BF50	021-1SD00
Figure				
Type	SM 021	SM 021	SM 021	SM 021
Module ID	0F03 47C2	0005 9FC1	0007 9FC1	0C41 2E00
<b>General information</b>				
Note	-	-	-	-
Features	<ul style="list-style-type: none"> <li>▸ 4 inputs</li> <li>▸ Time stamp</li> </ul>	<ul style="list-style-type: none"> <li>▸ 8 inputs</li> </ul>	<ul style="list-style-type: none"> <li>▸ 8 inputs</li> <li>▸ Active low input</li> </ul>	<ul style="list-style-type: none"> <li>▸ 4 inputs</li> <li>▸ Safety</li> </ul>
<b>Current consumption/power loss</b>				
Current consumption from backplane bus	85 mA	60 mA	65 mA	80 mA
Power loss	0.95 W	0.9 W	0.9 W	0.8 W
<b>Technical data digital inputs</b>				
Number of inputs	4	8	8	4
Cable length, shielded	1000 m	1000 m	1000 m	1000 m
Cable length, unshielded	600 m	600 m	600 m	600 m
Rated load voltage	DC 24 V	-	-	-
Current consumption from load voltage L+ (without load)	15 mA	-	-	-
Rated value	DC 20.4...28.8 V	DC 20.4...28.8 V	DC 20.4...28.8 V	DC 20.4...28.8 V
Input voltage for signal "0"	DC 0...5 V	DC 0...5 V	DC 15...28.8 V	DC 0...5 V
Input voltage for signal "1"	DC 15...28.8 V	DC 15...28.8 V	DC 0...5 V	DC 15...28.8 V
Input voltage hysteresis	-	-	-	-
Frequency range	-	-	-	-
Input resistance	-	-	-	-
Input current for signal "1"	3 mA	3 mA	3 mA	3 mA
Connection of Two-Wire-BEROs possible	✓	✓	✓	✓
Max. permissible BERO quiescent current	0.5 mA	0.5 mA	0.5 mA	1.5 mA
Input delay of "0" to "1"	parameterizable 2µs - 3ms	3 ms	3 ms	parameterizable 1ms - 1s
Input delay of "1" to "0"	parameterizable 2µs - 3ms	3 ms	3 ms	parameterizable 1ms - 1s
Number of simultaneously utilizable inputs horizontal configuration	4	8	8	4
Number of simultaneously utilizable inputs vertical configuration	4	8	8	4
Input characteristic curve	IEC 61131, type 1	IEC 61131, type 1	-	IEC 61131, type 3
Initial data size	60 Byte	8 Bit	8 Bit	4 Bit
<b>Status information, alarms, diagnostics</b>				
Status display	green LED per channel	green LED per channel	green LED per channel	green LED per channel
Interrupts	no	no	no	yes, parameterizable
Process alarm	no	no	no	no
Diagnostic interrupt	no	no	no	yes, parameterizable
Diagnostic functions	no	no	no	yes, parameterizable
Diagnostics information read-out	possible	none	none	possible

Signal modules digital   Digital input modules					
021-1BB00	021-1BD00	021-1BD70			
021-1BB10	021-1BD10	021-1BF00			
021-1BB50	021-1BD40	021-1BF50			
021-1BB70	021-1BD50	021-1SD00			

Order number	021-1BD70	021-1BF00	021-1BF50	021-1SD00
Module state	green LED	green LED	green LED	green LED
Module error display	red LED	red LED	red LED	red LED
Channel error display	none	none	none	none
<b>Isolation</b>				
Between channels	-	-	-	-
Between channels of groups to	-	-	-	-
Between channels and backplane bus	✓	✓	✓	✓
Insulation tested with	DC 500 V	DC 500 V	DC 500 V	DC 500 V
<b>Safety</b>				
Safety protocol	-	-	-	PROFIsafe V2
Safety requirements	-	-	-	SIL CL 3 and PL e
Secure user address	-	-	-	1 - 4095
Watchdog	-	-	-	parameterizable 10ms - 1s
Two channels	-	-	-	Each 2 of 4 inputs switchable
Test pulse outputs	-	-	-	4
<b>Datasizes</b>				
Input bytes	20 / 60	1	1	5
Output bytes	0	0	0	5
Parameter bytes	12	0	0	44
Diagnostic bytes	20	0	0	20
<b>Housing</b>				
Material	PPE / PPE GF10	PPE / PPE GF10	PPE / PPE GF10	PC / PPE GF10
Mounting	Profile rail 35 mm	Profile rail 35 mm	Profile rail 35 mm	Profile rail 35 mm
<b>Mechanical data</b>				
Dimensions (WxHxD)	12.9 mm x 109 mm x 76.5 mm	12.9 mm x 109 mm x 76.5 mm	12.9 mm x 109 mm x 76.5 mm	12.9 mm x 109 mm x 76.5 mm
Weight	60 g	60 g	60 g	60 g
<b>Environmental conditions</b>				
Operating temperature	0 °C to 60 °C	0 °C to 60 °C	0 °C to 60 °C	0 °C to 60 °C
Storage temperature	-25 °C to 70 °C	-25 °C to 70 °C	-25 °C to 70 °C	-25 °C to 70 °C
<b>Certifications</b>				
UL508 certification	yes	yes	yes	in preparation

# Connections, Interfaces

Signal modules digital | Digital input modules

021-1BB00	021-1BD00	021-1BD70
021-1BB10	021-1BD10	021-1BF00
021-1BB50	021-1BD40	021-1BF50
021-1BB70	021-1BD50	021-1SD00

021-1BD70

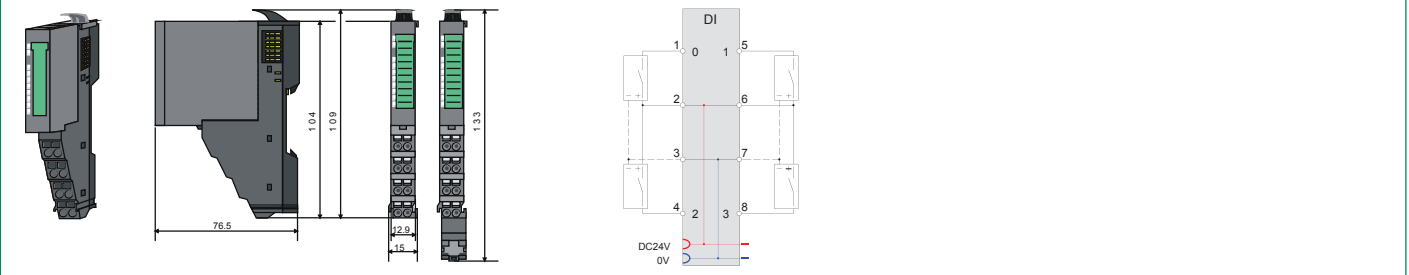

021-1BF00

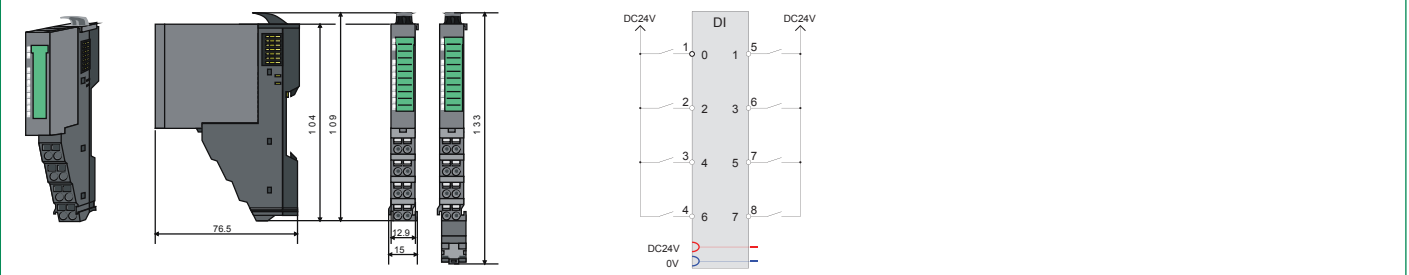

021-1BF50

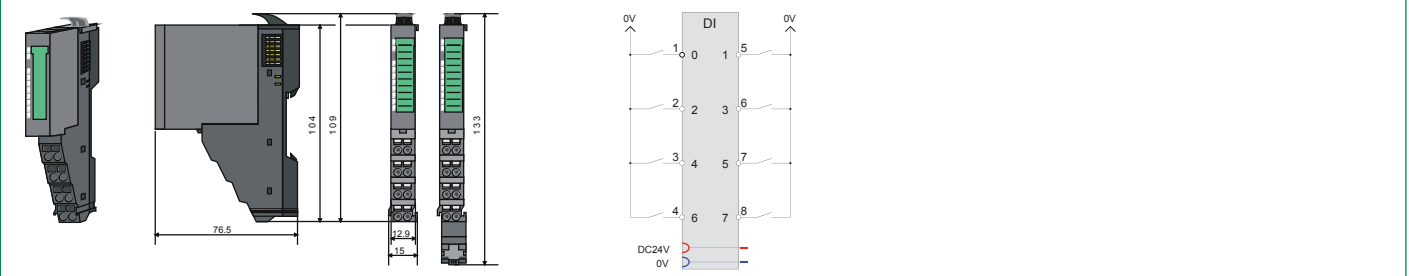



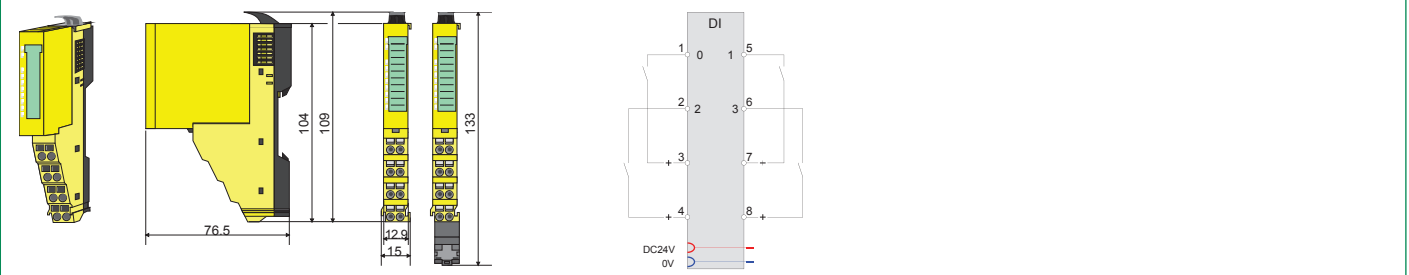

021-1SD00



# Digital output modules

Signal modules digital   Digital output modules						
022-1BB00	022-1BB90	022-1BD70	022-1SD00			
022-1BB20	022-1BD00	022-1BF00				
022-1BB50	022-1BD20	022-1BF50				
022-1BB70	022-1BD50	022-1HB10				

Order number	022-1BB00	022-1BB20	022-1BB50	022-1BB70
Figure				
Type	SM 022	SM 022	SM 022	SM 022
Module ID	0101 AF90	0102 AF90	0103 AF90	0F41 57E1
<b>General information</b>				
Note	-	-	-	-
Features	<ul style="list-style-type: none"> <li>▸ 2 outputs</li> <li>▸ Output current 0.5 A</li> </ul>	<ul style="list-style-type: none"> <li>▸ 2 outputs</li> <li>▸ Output current 2 A</li> </ul>	<ul style="list-style-type: none"> <li>▸ 2 Low-Side outputs</li> <li>▸ Output current 0.5 A</li> </ul>	<ul style="list-style-type: none"> <li>▸ 2 outputs</li> <li>▸ Time stamp</li> <li>▸ Output current 0.5 A</li> </ul>
<b>Current consumption/power loss</b>				
Current consumption from backplane bus	55 mA	60 mA	60 mA	85 mA
Power loss	0.4 W	0.55 W	0.4 W	0.95 W
<b>Technical data digital outputs</b>				
Number of outputs	2	2	2	2
Cable length, shielded	1000 m	1000 m	1000 m	1000 m
Cable length, unshielded	600 m	600 m	600 m	600 m
Rated load voltage	DC 20.4...28.8 V	DC 20.4...28.8 V	DC 20.4...28.8 V	DC 20.4...28.8 V
Current consumption from load voltage L+ (without load)	5 mA	10 mA	2.5 mA	15 mA
Total current per group, horizontal configuration, 40°C	1 A	4 A	1 A	1 A
Total current per group, horizontal configuration, 60°C	1 A	4 A	1 A	1 A
Total current per group, vertical configuration	1 A	4 A	1 A	1 A
Output current at signal "1", rated value	0.5 A	2 A	0.5 A	0.5 A
Output delay of "0" to "1"	30 µs	100 µs	30 µs	max. 100 ns
Output delay of "1" to "0"	175 µs	250 µs	100 µs	max. 100 ns
Minimum load current	-	-	-	-
Lamp load	10 W	10 W	10 W	10 W
Parallel switching of outputs for redundant control of a load	not possible	not possible	not possible	not possible
Parallel switching of outputs for increased power	not possible	not possible	not possible	not possible
Actuation of digital input	✓	✓	✓	✓
Switching frequency with resistive load	max. 1000 Hz	max. 1000 Hz	max. 1000 Hz	max. 40 kHz
Switching frequency with inductive load	max. 0.5 Hz	max. 0.5 Hz	max. 0.5 Hz	max. 40 kHz
Switching frequency on lamp load	max. 10 Hz	max. 10 Hz	max. 10 Hz	max. 40 kHz
Internal limitation of inductive shut-off voltage	L+ (-52 V)	L+ (-52 V)	+45 V	L+ (-52 V)
Short-circuit protection of output	yes, electronic	yes, electronic	yes, electronic	yes, electronic, and only highside
Trigger level	1 A	2.7 A	1.7 A	2.5 A
Number of operating cycle of relay outputs	-	-	-	-

## Signal modules digital | Digital output modules

022-1BB00	022-1BB90	022-1BD70	022-1SD00			
022-1BB20	022-1BD00	022-1BF00				
022-1BB50	022-1BD20	022-1BF50				
022-1BB70	022-1BD50	022-1HB10				

Order number	022-1BB00	022-1BB20	022-1BB50	022-1BB70
Switching capacity of contacts	-	-	-	-
Output data size	2 Bit	2 Bit	2 Bit	60 Byte
<b>Status information, alarms, diagnostics</b>				
Status display	green LED per channel	green LED per channel	green LED per channel	green LED per channel
Interrupts	no	no	no	no
Process alarm	no	no	no	no
Diagnostic interrupt	no	no	no	no
Diagnostic functions	no	no	no	no
Diagnostics information read-out	none	none	none	possible
Module state	green LED	green LED	green LED	green LED
Module error display	red LED	red LED	red LED	red LED
Channel error display	none	none	none	none
<b>Isolation</b>				
Between channels	-	-	-	-
Between channels of groups to	-	-	-	-
Between channels and backplane bus	✓	✓	✓	✓
Insulation tested with	DC 500 V	DC 500 V	DC 500 V	DC 500 V
<b>Safety</b>				
Safety protocol	-	-	-	-
Safety requirements	-	-	-	-
Secure user address	-	-	-	-
Watchdog	-	-	-	-
Two channels	-	-	-	-
Test pulse length	-	-	-	-
Circuit monitoring	-	-	-	-
<b>Datasizes</b>				
Input bytes	0	0	0	4
Output bytes	1	1	1	20 / 60
Parameter bytes	0	0	0	6
Diagnostic bytes	0	0	0	20
<b>Housing</b>				
Material	PPE / PPE GF10	PPE / PPE GF10	PPE / PPE GF10	PPE / PPE GF10
Mounting	Profile rail 35 mm	Profile rail 35 mm	Profile rail 35 mm	Profile rail 35 mm
<b>Mechanical data</b>				
Dimensions (WxHxD)	12.9 mm x 109 mm x 76.5 mm	12.9 mm x 109 mm x 76.5 mm	12.9 mm x 109 mm x 76.5 mm	12.9 mm x 109 mm x 76.5 mm
Weight	60 g	60 g	60 g	60 g
<b>Environmental conditions</b>				
Operating temperature	0 °C to 60 °C	0 °C to 60 °C	0 °C to 60 °C	0 °C to 60 °C
Storage temperature	-25 °C to 70 °C	-25 °C to 70 °C	-25 °C to 70 °C	-25 °C to 70 °C
<b>Certifications</b>				
UL508 certification	yes	yes	yes	yes

# Connections, Interfaces

Signal modules digital   Digital output modules					
022-1BB00	022-1BB90	022-1BD70	022-1SD00		
022-1BB20	022-1BD00	022-1BF00			
022-1BB50	022-1BD20	022-1BF50			
022-1BB70	022-1BD50	022-1HB10			

**022-1BB00**

Technical drawings of the 022-1BB00 module. The drawings include a perspective view, a side view with dimensions (76.5, 10.4, 10.9, 12.9, 15, 13.3), and a terminal block diagram. The terminal block diagram shows 8 pins with connections for DC24V (red) and OV (blue). The terminal block is labeled 'DO' and has pins numbered 1 through 8.

**022-1BB20**

Technical drawings of the 022-1BB20 module. The drawings include a perspective view, a side view with dimensions (76.5, 10.4, 10.9, 12.9, 15, 13.3), and a terminal block diagram. The terminal block diagram shows 8 pins with connections for DC24V (red) and OV (blue). The terminal block is labeled 'DO' and has pins numbered 1 through 8.

**022-1BB50**

Technical drawings of the 022-1BB50 module. The drawings include a perspective view, a side view with dimensions (76.5, 10.4, 10.9, 12.9, 15, 13.3), and a terminal block diagram. The terminal block diagram shows 8 pins with connections for DC24V (red) and OV (blue). The terminal block is labeled 'DO' and has pins numbered 1 through 8.





**022-1BB70**

Technical drawings of the 022-1BB70 module. The drawings include a perspective view, a side view with dimensions (76.5, 10.4, 10.9, 12.9, 15, 13.3), and a terminal block diagram. The terminal block diagram shows 8 pins with connections for DC24V (red) and OV (blue). The terminal block is labeled 'DO' and has pins numbered 1 through 8.

# Digital output modules

## Signal modules digital | Digital output modules

022-1BB00 022-1BB20 022-1BB50 022-1BB70	022-1BB90 022-1BD00 022-1BD20 022-1BD50	022-1BD70 022-1BF00 022-1BF50 022-1HB10	022-1SD00			
--	--	--	-----------	--	--	--

Order number	022-1BB90	022-1BD00	022-1BD20	022-1BD50
Figure				
Type	SM 022	SM 022	SM 022	SM 022
Module ID	0901 4880	0104 AFA0	0108 AFA0	0105 AFA0
<b>General information</b>				
Note	-	-	-	-
Features	<ul style="list-style-type: none"> <li>▸ 2 outputs</li> <li>▸ PWM</li> </ul>	<ul style="list-style-type: none"> <li>▸ 4 outputs</li> <li>▸ Output current 0.5 A</li> </ul>	<ul style="list-style-type: none"> <li>▸ 4 outputs</li> <li>▸ Output current 2 A</li> </ul>	<ul style="list-style-type: none"> <li>▸ 4 Low-Side outputs</li> <li>▸ Output current 0.5 A</li> </ul>
<b>Current consumption/power loss</b>				
Current consumption from backplane bus	85 mA	55 mA	65 mA	65 mA
Power loss	0.95 W	0.5 W	0.8 W	0.5 W
<b>Technical data digital outputs</b>				
Number of outputs	2	4	4	4
Cable length, shielded	1000 m	1000 m	1000 m	1000 m
Cable length, unshielded	600 m	600 m	600 m	600 m
Rated load voltage	DC 20.4...28.8 V	DC 20.4...28.8 V	DC 20.4...28.8 V	DC 20.4...28.8 V
Current consumption from load voltage L+ (without load)	15 mA	10 mA	20 mA	5 mA
Total current per group, horizontal configuration, 40°C	1 A	2 A	4 A	2 A
Total current per group, horizontal configuration, 60°C	1 A	2 A	4 A	2 A
Total current per group, vertical configuration	1 A	2 A	4 A	2 A
Output current at signal "1", rated value	0.5 A	0.5 A	2 A	0.5 A
Output delay of "0" to "1"	max. 100 ns	30 µs	100 µs	30 µs
Output delay of "1" to "0"	max. 100 ns	175 µs	250 µs	100 µs
Minimum load current	-	-	-	-
Lamp load	10 W	10 W	10 W	10 W
Parallel switching of outputs for redundant control of a load	not possible	not possible	not possible	not possible
Parallel switching of outputs for increased power	not possible	not possible	not possible	not possible
Actuation of digital input	✓	✓	✓	✓
Switching frequency with resistive load	max. 40 kHz	max. 1000 Hz	max. 1000 Hz	max. 1000 Hz
Switching frequency with inductive load	max. 40 kHz	max. 0.5 Hz	max. 0.5 Hz	max. 0.5 Hz
Switching frequency on lamp load	max. 40 kHz	max. 10 Hz	max. 10 Hz	max. 10 Hz
Internal limitation of inductive shut-off voltage	L+ (-52 V)	L+ (-52 V)	L+ (-52 V)	+45 V
Short-circuit protection of output	yes, electronic, and only highside	yes, electronic	yes, electronic	yes, electronic
Trigger level	2.5 A	1 A	2.7 A	1.7 A
Number of operating cycle of relay outputs	-	-	-	-
Switching capacity of contacts	-	-	-	-

Signal modules digital   Digital output modules						
022-1BB00	022-1BB90	022-1BD70	022-1SD00			
022-1BB20	022-1BD00	022-1BF00				
022-1BB50	022-1BD20	022-1BF50				
022-1BB70	022-1BD50	022-1HB10				

Order number	022-1BB90	022-1BD00	022-1BD20	022-1BD50
Output data size	12 Byte	4 Bit	4 Bit	4 Bit
<b>Status information, alarms, diagnostics</b>				
Status display	green LED per channel	green LED per channel	green LED per channel	green LED per channel
Interrupts	no	no	no	no
Process alarm	no	no	no	no
Diagnostic interrupt	no	no	no	no
Diagnostic functions	no	no	no	no
Diagnostics information read-out	possible	none	none	none
Module state	green LED	green LED	green LED	green LED
Module error display	red LED	red SF LED	red SF LED	red SF LED
Channel error display	none	none	none	none
<b>Isolation</b>				
Between channels	-	-	-	-
Between channels of groups to	-	-	-	-
Between channels and backplane bus	✓	✓	✓	✓
Insulation tested with	DC 500 V	DC 500 V	DC 500 V	DC 500 V
<b>Safety</b>				
Safety protocol	-	-	-	-
Safety requirements	-	-	-	-
Secure user address	-	-	-	-
Watchdog	-	-	-	-
Two channels	-	-	-	-
Test pulse length	-	-	-	-
Circuit monitoring	-	-	-	-
<b>Datasizes</b>				
Input bytes	4	0	0	0
Output bytes	12	1	1	1
Parameter bytes	12	0	0	0
Diagnostic bytes	20	0	0	0
<b>Housing</b>				
Material	PPE / PPE GF10	PPE / PPE GF10	PPE / PPE GF10	PPE / PPE GF10
Mounting	Profile rail 35 mm	Profile rail 35 mm	Profile rail 35 mm	Profile rail 35 mm
<b>Mechanical data</b>				
Dimensions (WxHxD)	12.9 mm x 109 mm x 76.5 mm	12.9 mm x 109 mm x 76.5 mm	12.9 mm x 109 mm x 76.5 mm	12.9 mm x 109 mm x 76.5 mm
Weight	60 g	60 g	60 g	60 g
<b>Environmental conditions</b>				
Operating temperature	0 °C to 60 °C	0 °C to 60 °C	0 °C to 60 °C	0 °C to 60 °C
Storage temperature	-25 °C to 70 °C	-25 °C to 70 °C	-25 °C to 70 °C	-25 °C to 70 °C
<b>Certifications</b>				
UL508 certification	yes	yes	yes	yes

# Connections, Interfaces

Signal modules digital | Digital output modules

022-1BB00	022-1BB90	022-1BD70	022-1SD00		
022-1BB20	022-1BD00	022-1BF00			
022-1BB50	022-1BD20	022-1BF50			
022-1BB70	022-1BD50	022-1HB10			

022-1BB90

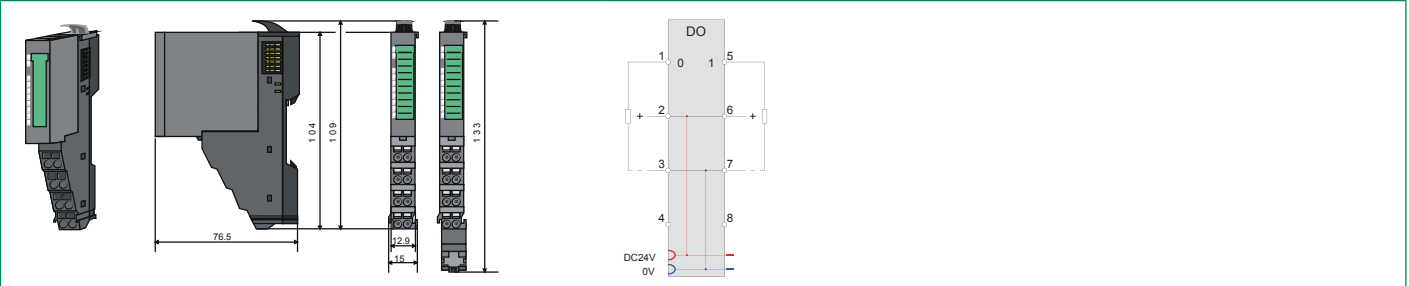

022-1BD00

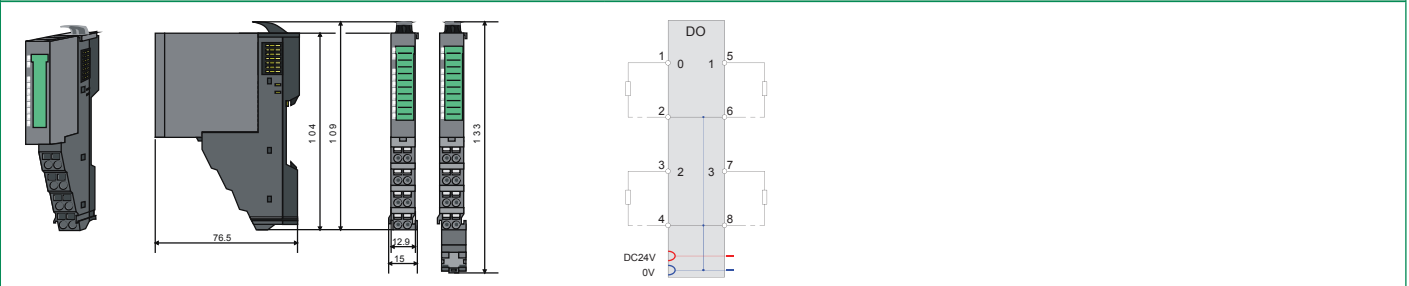

022-1BD20

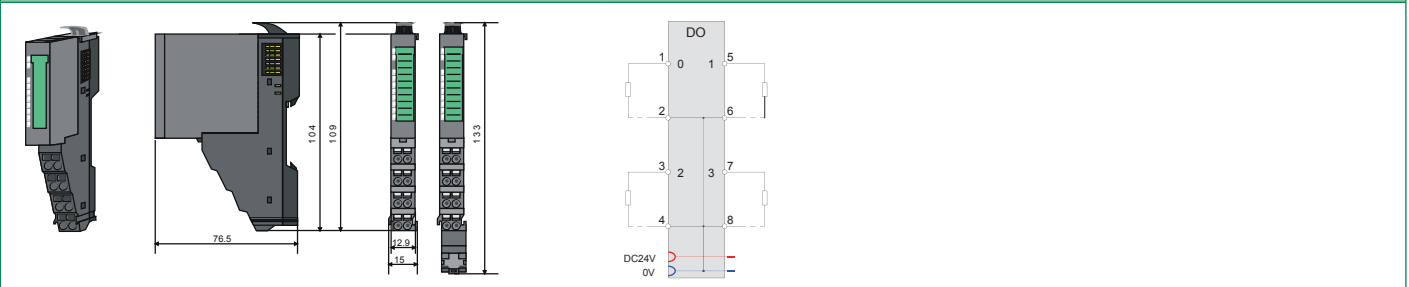



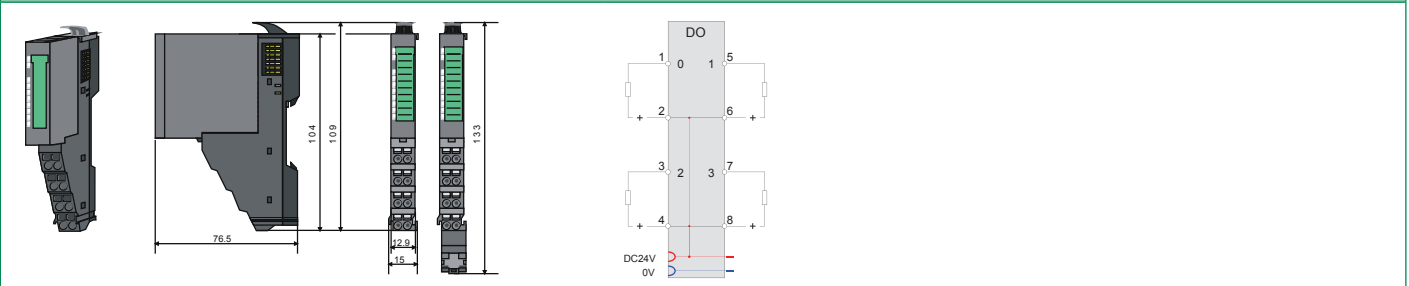

022-1BD50



# Digital output modules

Signal modules digital   Digital output modules					
022-1BB00	022-1BB90	022-1BD70	022-1SD00		
022-1BB20	022-1BD00	022-1BF00			
022-1BB50	022-1BD20	022-1BF50			
022-1BB70	022-1BD50	022-1HB10			

Order number	022-1BD70	022-1BF00	022-1BF50	022-1HB10
Figure				
Type	SM 022	SM 022	SM 022	SM 022
Module ID	0F43 57E2	0106 AFC8	0107 AFC8	0109 AF90
<b>General information</b>				
Note	-	-	-	-
Features	<ul style="list-style-type: none"> <li>▸ 4 outputs</li> <li>▸ Time stamp</li> <li>▸ Output current 0.5 A</li> </ul>	<ul style="list-style-type: none"> <li>▸ 8 outputs</li> <li>▸ Output current 0.5 A</li> </ul>	<ul style="list-style-type: none"> <li>▸ 8 Low-Side outputs</li> <li>▸ Output current 0.5 A</li> </ul>	<ul style="list-style-type: none"> <li>▸ 2 relay outputs</li> <li>▸ DC 30 V/ AC 230 V</li> <li>▸ Output current 3 A</li> </ul>
<b>Current consumption/power loss</b>				
Current consumption from backplane bus	90 mA	65 mA	70 mA	130 mA
Power loss	0.95 W	0.7 W	0.6 W	0.7 W
<b>Technical data digital outputs</b>				
Number of outputs	4	8	8	2
Cable length, shielded	1000 m	1000 m	1000 m	-
Cable length, unshielded	600 m	600 m	600 m	-
Rated load voltage	DC 20.4...28.8 V	DC 20.4...28.8 V	DC 20.4...28.8 V	DC 30 V/ AC 230 V
Current consumption from load voltage L+ (without load)	25 mA	15 mA	10 mA	-
Total current per group, horizontal configuration, 40°C	2 A	4 A	2.5 A	-
Total current per group, horizontal configuration, 60°C	2 A	4 A	2.5 A	-
Total current per group, vertical configuration	2 A	4 A	2.5 A	-
Output current at signal "1", rated value	0.5 A	0.5 A	0.5 A	3 A
Output delay of "0" to "1"	max. 100 ns	30 µs	30 µs	-
Output delay of "1" to "0"	max. 100 ns	175 µs	100 µs	-
Minimum load current	-	-	-	-
Lamp load	10 W	10 W	10 W	-
Parallel switching of outputs for redundant control of a load	not possible	not possible	not possible	-
Parallel switching of outputs for increased power	not possible	not possible	not possible	-
Actuation of digital input	✓	✓	✓	-
Switching frequency with resistive load	max. 40 kHz	max. 1000 Hz	max. 1000 Hz	max. 100 Hz
Switching frequency with inductive load	max. 40 kHz	max. 0.5 Hz	max. 0.5 Hz	-
Switching frequency on lamp load	max. 40 kHz	max. 10 Hz	max. 10 Hz	-
Internal limitation of inductive shut-off voltage	L+ (-52 V)	L+ (-52 V)	+45 V	-
Short-circuit protection of output	yes, electronic, and only highside	yes, electronic	yes, electronic	-
Trigger level	2.5 A	1 A	1.7 A	-
Number of operating cycle of relay outputs	-	-	-	-

Signal modules digital   Digital output modules					
022-1BB00	022-1BB90	022-1BD70	022-1SD00		
022-1BB20	022-1BD00	022-1BF00			
022-1BB50	022-1BD20	022-1BF50			
022-1BB70	022-1BD50	022-1HB10			

Order number	022-1BD70	022-1BF00	022-1BF50	022-1HB10
Switching capacity of contacts	-	-	-	3 A
Output data size	60 Byte	8 Bit	8 Bit	2 Bit
<b>Status information, alarms, diagnostics</b>				
Status display	green LED per channel	green LED per channel	red LED per channel	red LED per channel
Interrupts	no	no	no	no
Process alarm	no	no	no	no
Diagnostic interrupt	no	no	no	no
Diagnostic functions	no	no	no	no
Diagnostics information read-out	possible	none	none	none
Module state	green LED	green LED	green LED	green LED
Module error display	red SF LED	red SF LED	red LED	red LED
Channel error display	none	none	none	none
<b>Isolation</b>				
Between channels	-	-	-	✓
Between channels of groups to	-	-	-	-
Between channels and backplane bus	✓	✓	✓	✓
Insulation tested with	DC 500 V	DC 500 V	DC 500 V	DC 500 V
<b>Safety</b>				
Safety protocol	-	-	-	-
Safety requirements	-	-	-	-
Secure user address	-	-	-	-
Watchdog	-	-	-	-
Two channels	-	-	-	-
Test pulse length	-	-	-	-
Circuit monitoring	-	-	-	-
<b>Datasizes</b>				
Input bytes	4	0	0	0
Output bytes	20 / 60	1	1	1
Parameter bytes	6	0	0	0
Diagnostic bytes	20	0	0	0
<b>Housing</b>				
Material	PPE / PPE GF10	PPE / PPE GF10	PPE / PPE GF10	PPE / PPE GF10
Mounting	Profile rail 35 mm	Profile rail 35 mm	Profile rail 35 mm	Profile rail 35 mm
<b>Mechanical data</b>				
Dimensions (WxHxD)	12.9 mm x 109 mm x 76.5 mm	12.9 mm x 109 mm x 76.5 mm	12.9 mm x 109 mm x 76.5 mm	12.9 mm x 109 mm x 76.5 mm
Weight	60 g	60 g	60 g	60 g
<b>Environmental conditions</b>				
Operating temperature	0 °C to 60 °C	0 °C to 60 °C	0 °C to 60 °C	0 °C to 60 °C
Storage temperature	-25 °C to 70 °C	-25 °C to 70 °C	-25 °C to 70 °C	-25 °C to 70 °C
<b>Certifications</b>				
UL508 certification	yes	yes	yes	yes

# Connections, Interfaces

Signal modules digital   Digital output modules					
022-1BB00	022-1BB90	022-1BD70	022-1SD00		
022-1BB20	022-1BD00	022-1BF00			
022-1BB50	022-1BD20	022-1BF50			
022-1BB70	022-1BD50	022-1HB10			

### 022-1BD70

Technical drawing of the 022-1BD70 module showing front, side, and rear views with dimensions: 76.5, 10.4, 10.9, 12.9, 15, 13.3. A terminal block diagram shows 8 channels with terminals 1-8 and 5-8, and DC24V/0V connections.

### 022-1BF00

Technical drawing of the 022-1BF00 module showing front, side, and rear views with dimensions: 76.5, 10.4, 10.9, 12.9, 15, 13.3. A terminal block diagram shows 8 channels with terminals 1-8 and 5-8, and DC24V/0V connections.

### 022-1BF50

Technical drawing of the 022-1BF50 module showing front, side, and rear views with dimensions: 76.5, 10.4, 10.9, 12.9, 15, 13.3. A terminal block diagram shows 8 channels with terminals 1-8 and 5-8, and DC24V/0V connections.

### 022-1HB10

Technical drawing of the 022-1HB10 module showing front, side, and rear views with dimensions: 76.5, 10.4, 10.9, 12.9, 15, 13.3. A terminal block diagram shows 8 channels with terminals 1-8 and 5-8, and AC 230V/DC 30V 3A and DC 24V/0V connections.

# Digital output modules

Signal modules digital   Digital output modules						
022-1BB00	022-1BB90	022-1BD70	022-1SD00			
022-1BB20	022-1BD00	022-1BF00				
022-1BB50	022-1BD20	022-1BF50				
022-1BB70	022-1BD50	022-1HB10				

Order number	022-1SD00			
Figure				
Type	SM 022			
Module ID	0C81 1E00			
<b>General information</b>				
Note	-			
Features	<ul style="list-style-type: none"> <li>▸ 4 outputs</li> <li>▸ Safety</li> <li>▸ Output current 0.5 A</li> </ul>			
<b>Current consumption/power loss</b>				
Current consumption from backplane bus	80 mA			
Power loss	1.2 W			
<b>Technical data digital outputs</b>				
Number of outputs	4			
Cable length, shielded	1000 m			
Cable length, unshielded	600 m			
Rated load voltage	DC 20.4...28.8 V			
Current consumption from load voltage L+ (without load)	10 mA			
Total current per group, horizontal configuration, 40°C	2 A			
Total current per group, horizontal configuration, 60°C	2 A			
Total current per group, vertical configuration	2 A			
Output current at signal "1", rated value	0.5 A			
Output delay of "0" to "1"	100 µs			
Output delay of "1" to "0"	175 µs			
Minimum load current	-			
Lamp load	5 W			
Parallel switching of outputs for redundant control of a load	not possible			
Parallel switching of outputs for increased power	not possible			
Actuation of digital input	✓			
Switching frequency with resistive load	max. 100 Hz			
Switching frequency with inductive load	max. 0.5 Hz			
Switching frequency on lamp load	max. 10 Hz			
Internal limitation of inductive shut-off voltage	L+ (-52 V)			
Short-circuit protection of output	yes, electronic			
Trigger level	1.7 A			
Number of operating cycle of relay outputs	-			
Switching capacity of contacts	-			

Signal modules digital   Digital output modules						
022-1BB00	022-1BB90	022-1BD70	022-1SD00			
022-1BB20	022-1BD00	022-1BF00				
022-1BB50	022-1BD20	022-1BF50				
022-1BB70	022-1BD50	022-1HB10				

Order number	022-1SD00			
Output data size	4 Bit			
<b>Status information, alarms, diagnostics</b>				
Status display	green LED per channel			
Interrupts	yes, parameterizable			
Process alarm	no			
Diagnostic interrupt	yes, parameterizable			
Diagnostic functions	yes, parameterizable			
Diagnostics information read-out	possible			
Module state	green LED			
Module error display	red SF LED			
Channel error display	none			
<b>Isolation</b>				
Between channels	-			
Between channels of groups to	-			
Between channels and backplane bus	✓			
Insulation tested with	DC 500 V			
<b>Safety</b>				
Safety protocol	PROFIsafe V2			
Safety requirements	SIL CL 3 and PL e			
Secure user address	1 - 4095			
Watchdog	parameterizable 10ms - 1s			
Two channels	Each 2 of 4 outputs switchable			
Test pulse length	parameterizable 500µs - 16ms			
Circuit monitoring	✓			
<b>Datasizes</b>				
Input bytes	5			
Output bytes	5			
Parameter bytes	44			
Diagnostic bytes	20			
<b>Housing</b>				
Material	PC / PPE GF10			
Mounting	Profile rail 35 mm			
<b>Mechanical data</b>				
Dimensions (WxHxD)	12.9 mm x 109 mm x 76.5 mm			
Weight	60 g			
<b>Environmental conditions</b>				
Operating temperature	0 °C to 60 °C			
Storage temperature	-25 °C to 70 °C			
<b>Certifications</b>				
UL508 certification	in preparation			

# Connections, Interfaces

## Signal modules digital | Digital output modules

022-1BB00	022-1BB90	022-1BD70	022-1SD00			
022-1BB20	022-1BD00	022-1BF00				
022-1BB50	022-1BD20	022-1BF50				
022-1BB70	022-1BD50	022-1HB10				

### 022-1SD00

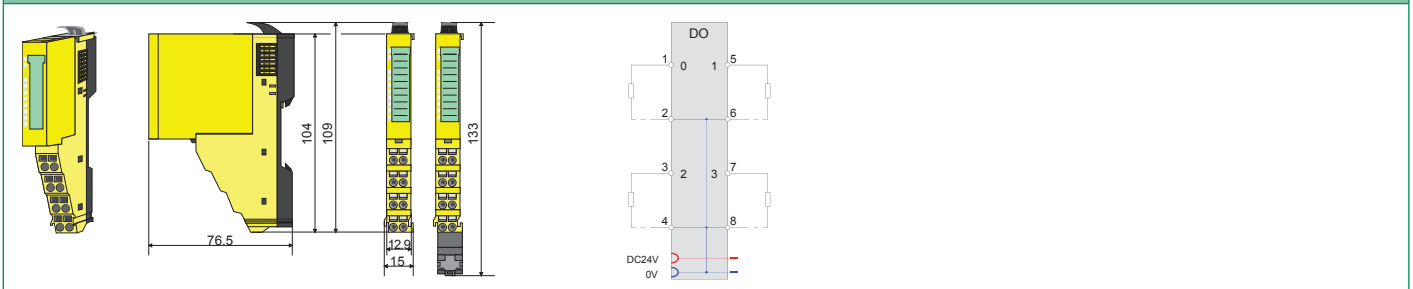

# Signal modules analog



## Structure and Function

Signal modules (SM) to connect sensors and actuators are the interfaces of the system to the process. Analog signal modules acquire the analog control signals (e.g. measurement data) to and out of the process level. Depending on the application and type the control signals are acquired from the process level and converted into interpretable signals for controlling. Analog output modules convert the internal control signals into signals suitable for the process level.

A variety of different analog signal modules accurately provide the inputs and outputs that are required for each task. The analog modules differ in the number of channels, voltage and current ranges, isolation, and diagnostic and alarm capability.

Each signal module consists of a terminal and an electronics module.

The terminal module (TM) contains the retainer for the electronic module (EM), the backplane connectors and contacts for the distribution of the load power supply electronics, the modular connection to DC 24 V load power supply and the staircase-shaped terminal block for the wiring.

Furthermore the terminal module processes a locking system for fixing to a profile rail. The SLIO system can also be constructed "block by block" outside the cabinet and later assembled as a complete system in the control cabinet.

The functionality of the signal module is defined via the electronics module that is connected by a secure sliding mechanism to the terminal module.

During service the defective electronic module can be replaced without detaching the wiring.

## Characteristics

- › 2 or 4 channel
- › 12 bit or 16 bit resolution
- › Functions of the inputs / outputs programmable
- › Most various assemblies, suitable for measuring transducers (current/voltage, resistance or temperature sensors)
- › Direct mapping and readability of the channel conditions via status LEDs
- › Safe and time-saving installation by the terminal assignment mounted on the module
- › When changing the module equipment identification (BMK) is retained on the TM
- › Individual single-channel lettering on insertion strip
- › 24 month warranty

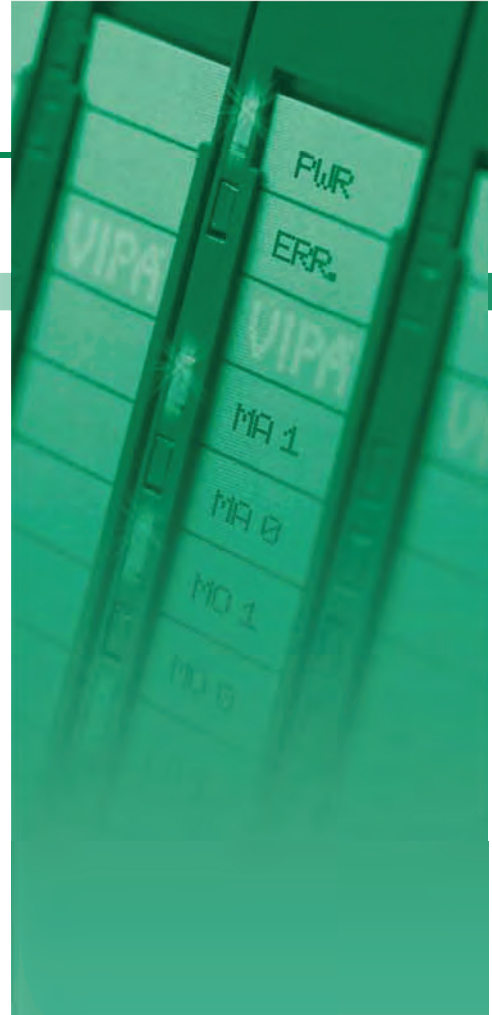

# Overview

Order no.	Name/Description	Page
<b>Analog input modules</b>		
031-1BB10	<b>SM 031 - Analog input</b> ▶ 2 inputs 12Bit ▶ Current 4...20 mA ▶ 2 wire	53
031-1BB30	<b>SM 031 - Analog input</b> ▶ 2 inputs 12Bit ▶ Voltage 0...10 V	53
031-1BB40	<b>SM 031 - Analog input</b> ▶ 2 inputs 12Bit ▶ Current 0(4)...20 mA	53
031-1BB60	<b>SM 031 - Analog input</b> ▶ 2 inputs 12Bit ▶ Current 4...20 mA ▶ 2 wire	53
031-1BB70	<b>SM 031 - Analog input</b> ▶ 2 inputs 12Bit ▶ Voltage -10 V...+10 V	57
031-1BB90	<b>SM 031 - Analog input</b> ▶ 2 inputs 16Bit ▶ Thermocouple ▶ Voltage -80mV...+80mV	57
031-1BD30	<b>SM 031 - Analog input</b> ▶ 4 inputs 12Bit ▶ Voltage 0...10 V	57
031-1BD40	<b>SM 031 - Analog input</b> ▶ 4 inputs 12Bit ▶ Current 0(4)...20 mA	57
031-1BD70	<b>SM 031 - Analog input</b> ▶ 4 inputs 12Bit ▶ Voltage -10 V...+10 V	61
031-1BD80	<b>SM 031 - Analog input</b> ▶ 4 inputs 16Bit ▶ 0 .. 3000 ohm resistance ▶ Resistance measurment with 2, 3, and 4-wires	61
031-1CB30	<b>SM 031 - Analog input</b> ▶ 2 inputs 16Bit ▶ Voltage 0...10 V	61
031-1CB40	<b>SM 031 - Analog input</b> ▶ 2 inputs 16Bit ▶ Current 0(4)...20 mA	61
031-1CB70	<b>SM 031 - Analog input</b> ▶ 2 inputs 16Bit ▶ Voltage -10 V...+10 V	65
031-1CD30	<b>SM 031 - Analog input</b> ▶ 4 inputs 16Bit ▶ Voltage 0...10 V	65
031-1CD40	<b>SM 031 - Analog input</b> ▶ 4 inputs 16Bit ▶ Current 0(4)...20 mA	65
031-1CD70	<b>SM 031 - Analog input</b> ▶ 4 inputs 16Bit ▶ Voltage -10 V...+10 V	65
031-1LB90	<b>SM 031 - Analog input</b> ▶ 2 inputs 16Bit ▶ Thermocouple ▶ Voltage -80mV...+80mV	69
031-1LD80	<b>SM 031 - Analog input</b> ▶ 4 inputs 16Bit ▶ 0 .. 3000 ohm resistance ▶ Resistance measurment with 2, 3, and 4-wires	69
<b>Analog output modules</b>		
032-1BB30	<b>SM 032 - Analog output</b> ▶ 2 outputs 12Bit ▶ Voltage 0...10 V	73
032-1BB40	<b>SM 032 - Analog output</b> ▶ 2 outputs 12Bit ▶ Current 0(4)...20 mA	73

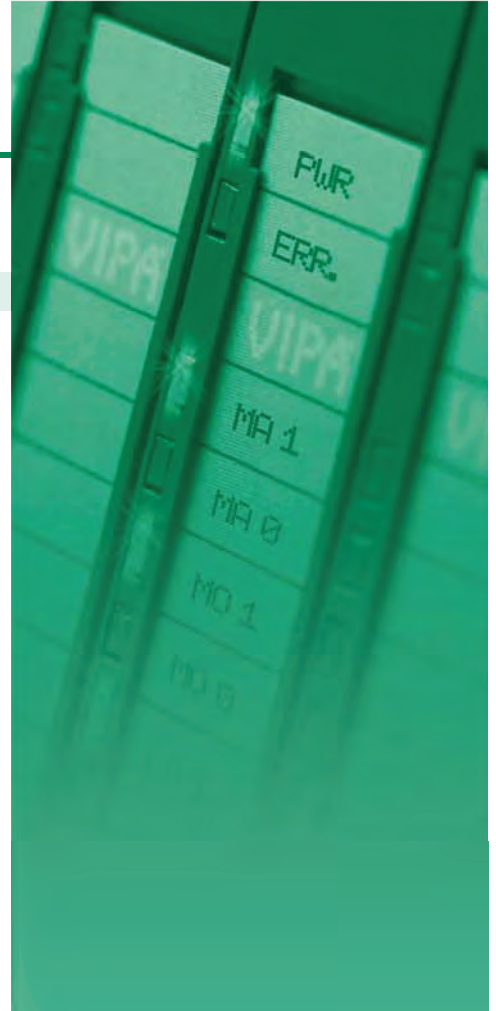



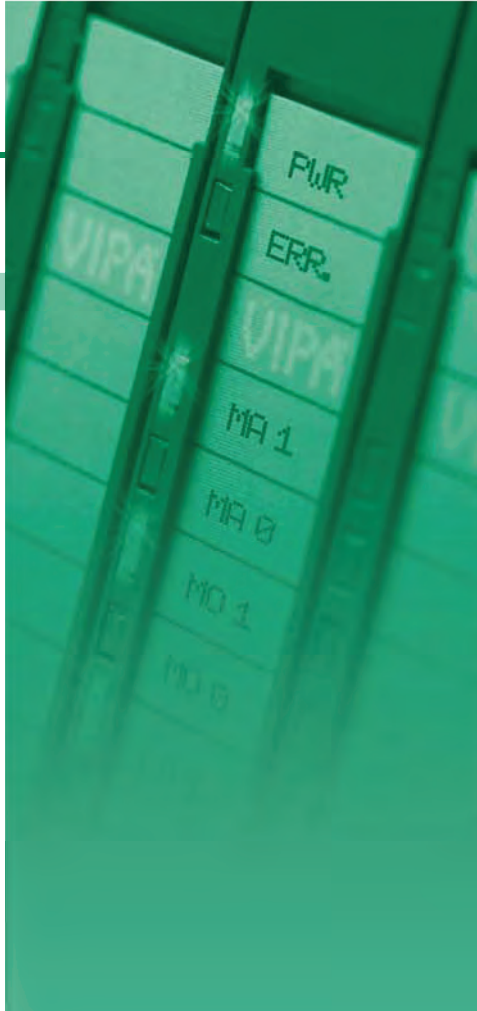

# Overview

Order no.	Name/Description	Page
032-1BB70	<b>SM 032 - Analog output</b> ▶ 2 outputs 12Bit ▶ Voltage -10 V...+10 V	73
032-1BD30	<b>SM 032 - Analog output</b> ▶ 4 outputs 12Bit ▶ Voltage 0...10 V	73
032-1BD40	<b>SM 032 - Analog output</b> ▶ 4 outputs 12Bit ▶ Current 0(4)...20mA	76
032-1BD70	<b>SM 032 - Analog output</b> ▶ 4 outputs 12Bit ▶ Voltage -10 V...+10 V	76
032-1CB30	<b>SM 032 - Analog output</b> ▶ 2 outputs 16Bit ▶ Voltage 0...10 V	76
032-1CB70	<b>SM 032 - Analog output</b> ▶ 2 outputs 16Bit ▶ Voltage -10 V...+10 V	76
032-1CD30	<b>SM 032 - Analog output</b> ▶ 4 outputs 16Bit ▶ Voltage 0...10 V	79
032-1CD70	<b>SM 032 - Analog output</b> ▶ 4 outputs 16Bit ▶ Voltage -10 V...+10 V	79



# Analog input modules

Signal modules analog   Analog input modules						
031-1BB10	031-1BB70	031-1BD70	031-1CB70	031-1LB90		
031-1BB30	031-1BB90	031-1BD80	031-1CD30	031-1LD80		
031-1BB40	031-1BD30	031-1CB30	031-1CD40			
031-1BB60	031-1BD40	031-1CB40	031-1CD70			

Order number	031-1BB10	031-1BB30	031-1BB40	031-1BB60
Figure				
Type	SM 031	SM 031	SM 031	SM 031
Module ID	0411 1543	0401 15C3	0402 15C3	0407 15C3
<b>General information</b>				
Note	-	-	-	-
Features	<ul style="list-style-type: none"> <li>▶ 2 inputs 12Bit</li> <li>▶ Current 4...20 mA</li> <li>▶ 2 wire</li> </ul>	<ul style="list-style-type: none"> <li>▶ 2 inputs 12Bit</li> <li>▶ Voltage 0...10 V</li> </ul>	<ul style="list-style-type: none"> <li>▶ 2 inputs 12Bit</li> <li>▶ Current 0(4)...20 mA</li> </ul>	<ul style="list-style-type: none"> <li>▶ 2 inputs 12Bit</li> <li>▶ Current 4...20 mA</li> <li>▶ 2 wire</li> </ul>
<b>Current consumption/power loss</b>				
Current consumption from backplane bus	50 mA	70 mA	70 mA	50 mA
Power loss	0.7 W	0.7 W	0.7 W	0.7 W
<b>Technical data analog inputs</b>				
Number of inputs	2	2	2	2
Cable length, shielded	200 m	200 m	200 m	200 m
Rated load voltage	DC 24 V	DC 24 V	DC 24 V	DC 24 V
Current consumption from load voltage L+ (without load)	20 mA	15 mA	15 mA	15 mA
Voltage inputs	-	✓	-	-
Min. input resistance (voltage range)	-	100 kΩ	-	-
Input voltage ranges	-	0 V ... +10 V	-	-
Operational limit of voltage ranges	-	+/-0.3%	-	-
Operational limit of voltage ranges with SFU	-	-	-	-
Basic error limit voltage ranges	-	+/-0.2%	-	-
Basic error limit voltage ranges with SFU	-	-	-	-
Current inputs	✓	-	✓	✓
Min. input resistance (current range)	60 Ω	-	110 Ω	110 Ω
Input current ranges	+4 mA ... +20 mA 0 mA ... +20 mA	-	0 mA ... +20 mA +4 mA ... +20 mA	0 mA ... +20 mA +4 mA ... +20 mA
Operational limit of current ranges	+/-0.5%	-	+/-0.3% ... +/-0.5%	+/-0.5%
Operational limit of current ranges with SFU	-	-	-	-
Basic error limit current ranges	+/-0.3%	-	+/-0.2% ... +/-0.3%	+/-0.3%
Basic error limit current ranges with SFU	-	-	-	-
Resistance inputs	-	-	-	-
Resistance ranges	-	-	-	-
Operational limit of resistor ranges	-	-	-	-
Basic error limit	-	-	-	-
Resistance thermometer inputs	-	-	-	-
Resistance thermometer ranges	-	-	-	-
Operational limit of resistance thermometer ranges	-	-	-	-

Signal modules analog   Analog input modules						
031-1BB10	031-1BB70	031-1BD70	031-1CB70	031-1LB90		
031-1BB30	031-1BB90	031-1BD80	031-1CD30	031-1LD80		
031-1BB40	031-1BD30	031-1CB30	031-1CD40			
031-1BB60	031-1BD40	031-1CB40	031-1CD70			

Order number	031-1BB10	031-1BB30	031-1BB40	031-1BB60
Operational limit of resistor ranges with SFU	-	-	-	-
Basic error limit thermoresistor ranges	-	-	-	-
Operational limit of resistor ranges with SFU	-	-	-	-
Thermocouple inputs	-	-	-	-
Thermocouple ranges	-	-	-	-
Operational limit of thermocouple ranges	-	-	-	-
Operational limit of thermocouple ranges with SFU	-	-	-	-
Basic error limit thermoelement ranges	-	-	-	-
Basic error limit thermoelement ranges with SFU	-	-	-	-
Programmable temperature compensation	-	-	-	-
External temperature compensation	-	-	-	-
Internal temperature compensation	-	-	-	-
Resolution in bit	12	12	12	12
Measurement principle	successive approximation	successive approximation	successive approximation	successive approximation
Basic conversion time	1.15 ms all channels	2 ms all channels	2 ms all channels	2 ms all channels
Noise suppression for frequency	>80dB (UCM<20V)	>50dB at 50Hz (UCM<2V)	>50dB at 50Hz (UCM<2V)	>50dB at 50Hz (UCM<2V)
<b>Status information, alarms, diagnostics</b>				
Status display	yes	yes	yes	yes
Interrupts	yes, parameterizable	no	no	no
Process alarm	yes, parameterizable	no	no	no
Diagnostic interrupt	yes, parameterizable	no	no	no
Diagnostic functions	yes	yes	yes	yes
Diagnostics information read-out	possible	possible	possible	possible
Module state	green LED	green LED	green LED	green LED
Module error display	red LED	red LED	red LED	red LED
Channel error display	red LED per channel	red LED per channel	red LED per channel	red LED per channel
<b>Isolation</b>				
Between channels	✓	-	-	-
Between channels of groups to	1	-	-	-
Between channels and backplane bus	✓	✓	✓	✓
Between channels and power supply	✓	✓	✓	-
Max. potential difference between circuits	DC 75 V/ AC 60 V	-	-	-
Max. potential difference between inputs (Ucm)	DC 75 V/ AC 60 V	DC 2 V	DC 2 V	-
Max. potential difference between Mana and Mintern (Uiso)	-	-	-	-
Max. potential difference between inputs and Mana (Ucm)	DC 75 V/ AC 60 V	-	-	-
Max. potential difference between inputs and Mintern (Uiso)	DC 75 V/ AC 60 V	DC 75 V/ AC 60 V	DC 75 V/ AC 60 V	DC 75 V/ AC 60 V
Max. potential difference between Mintern and outputs	-	-	-	-

Signal modules analog | Analog input modules

031-1BB10	031-1BB70	031-1BD70	031-1CB70	031-1LB90		
031-1BB30	031-1BB90	031-1BD80	031-1CD30	031-1LD80		
031-1BB40	031-1BD30	031-1CB30	031-1CD40			
031-1BB60	031-1BD40	031-1CB40	031-1CD70			

Order number	031-1BB10	031-1BB30	031-1BB40	031-1BB60
Insulation tested with	DC 500 V	DC 500 V	DC 500 V	DC 500 V
<b>Datasizes</b>				
Input bytes	4	4	4	4
Output bytes	0	0	0	0
Parameter bytes	15	6	6	6
Diagnostic bytes	20	20	20	20
<b>Housing</b>				
Material	PPE / PPE GF10	PPE / PPE GF10	PPE / PPE GF10	PPE / PPE GF10
Mounting	Profile rail 35 mm	Profile rail 35 mm	Profile rail 35 mm	Profile rail 35 mm
<b>Mechanical data</b>				
Dimensions (WxHxD)	12.9 mm x 109 mm x 76.5 mm	12.9 mm x 109 mm x 76.5 mm	12.9 mm x 109 mm x 76.5 mm	12.9 mm x 109 mm x 76.5 mm
Weight	60 g	60 g	60 g	60 g
<b>Environmental conditions</b>				
Operating temperature	0 °C to 60 °C	0 °C to 60 °C	0 °C to 60 °C	0 °C to 60 °C
Storage temperature	-25 °C to 70 °C	-25 °C to 70 °C	-25 °C to 70 °C	-25 °C to 70 °C
<b>Certifications</b>				
UL508 certification	in preparation	yes	yes	in preparation

# Connections, Interfaces

Signal modules analog   Analog input modules					
031-1BB10	031-1BB70	031-1BD70	031-1CB70	031-1LB90	
031-1BB30	031-1BB90	031-1BD80	031-1CD30	031-1LD80	
031-1BB40	031-1BD30	031-1CB30	031-1CD40		
031-1BB60	031-1BD40	031-1CB40	031-1CD70		

**031-1BB10**

**031-1BB30**





**031-1BB40**

**031-1BB60**

SLO  
100V  
200V  
300S  
500S  
HMI  
Software  
Accessories  
Appendix

# Analog input modules

Signal modules analog   Analog input modules					
031-1BB10	031-1BB70	031-1BD70	031-1CB70	031-1LB90	
031-1BB30	031-1BB90	031-1BD80	031-1CD30	031-1LD80	
031-1BB40	031-1BD30	031-1CB30	031-1CD40		
031-1BB60	031-1BD40	031-1CB40	031-1CD70		

Order number	031-1BB70	031-1BB90	031-1BD30	031-1BD40
Figure				
Type	SM 031	SM 031	SM 031	SM 031
Module ID	0408 15C3	0403 1543	0404 15C4	0405 15C4
<b>General information</b>				
Note	-	-	-	-
Features	<ul style="list-style-type: none"> <li>▸ 2 inputs 12Bit</li> <li>▸ Voltage -10 V...+10 V</li> </ul>	<ul style="list-style-type: none"> <li>▸ 2 inputs 16Bit</li> <li>▸ Thermocouple</li> <li>▸ Voltage -80mV...+80mV</li> </ul>	<ul style="list-style-type: none"> <li>▸ 4 inputs 12Bit</li> <li>▸ Voltage 0...+10 V</li> </ul>	<ul style="list-style-type: none"> <li>▸ 4 inputs 12Bit</li> <li>▸ Current 0(4)...20 mA</li> </ul>
<b>Current consumption/power loss</b>				
Current consumption from backplane bus	50 mA	75 mA	70 mA	70 mA
Power loss	0.5 W	1.1 W	0.7 W	0.7 W
<b>Technical data analog inputs</b>				
Number of inputs	2	2	4	4
Cable length, shielded	200 m	200 m	200 m	200 m
Rated load voltage	DC 24 V	DC 24 V	DC 24 V	DC 24 V
Current consumption from load voltage L+ (without load)	15 mA	30 mA	15 mA	15 mA
Voltage inputs	✓	-	✓	-
Min. input resistance (voltage range)	100 kΩ	10 MΩ	100 kΩ	-
Input voltage ranges	-10 V ... +10 V	-80 mV ... +80 mV	0 V ... +10 V	-
Operational limit of voltage ranges	+/-0.3%	±0.3%	+/-0.3%	-
Operational limit of voltage ranges with SFU	-	±0.1%	-	-
Basic error limit voltage ranges	+/-0.2%	±0.25%	+/-0.2%	-
Basic error limit voltage ranges with SFU	-	±0.05%	-	-
Current inputs	-	-	-	✓
Min. input resistance (current range)	-	-	-	110 Ω
Input current ranges	-	-	-	0 mA ... +20 mA +4 mA ... +20 mA
Operational limit of current ranges	-	-	-	+/-0.3% ... +/-0.5%
Operational limit of current ranges with SFU	-	-	-	-
Basic error limit current ranges	-	-	-	+/-0.2% ... +/-0.3%
Basic error limit current ranges with SFU	-	-	-	-
Resistance inputs	-	-	-	-
Resistance ranges	-	-	-	-
Operational limit of resistor ranges	-	-	-	-
Basic error limit	-	-	-	-
Resistance thermometer inputs	-	-	-	-
Resistance thermometer ranges	-	-	-	-
Operational limit of resistance thermometer ranges	-	-	-	-

Signal modules analog   Analog input modules						
031-1BB10	031-1BB70	031-1BD70	031-1CB70	031-1LB90		
031-1BB30	031-1BB90	031-1BD80	031-1CD30	031-1LD80		
031-1BB40	031-1BD30	031-1CB30	031-1CD40			
031-1BB60	031-1BD40	031-1CB40	031-1CD70			

Order number	031-1BB70	031-1BB90	031-1BD30	031-1BD40
Operational limit of resistor ranges with SFU	-	-	-	-
Basic error limit thermoresistor ranges	-	-	-	-
Operational limit of resistor ranges with SFU	-	-	-	-
Thermocouple inputs	-	✓	-	-
Thermocouple ranges	-	type B type C type E type J type K type L type N type R type S type T	-	-
Operational limit of thermocouple ranges	-	Type E, L, T, J, K, N: ±2.5K / Type B, C, R, S: ±8.0K	-	-
Operational limit of thermocouple ranges with SFU	-	Type E, L, T, J, K, N: ±1.5K / Type B, C, R, S: ±4.0K	-	-
Basic error limit thermoelement ranges	-	Type E, L, T, J, K, N: ±2.0K / Type B, C, R, S: ±7.0K	-	-
Basic error limit thermoelement ranges with SFU	-	Type E, L, T, J, K, N: ±1.0K / Type B, C, R, S: ±3.0K	-	-
Programmable temperature compensation	-	✓	-	-
External temperature compensation	-	✓	-	-
Internal temperature compensation	-	✓	-	-
Resolution in bit	12	16	12	12
Measurement principle	successive approximation	Sigma-Delta	successive approximation	successive approximation
Basic conversion time	2 ms all channels	4.2...324.1 ms (50 Hz) 3.8...270.5 ms (60 Hz) per channel	4 ms all channels	4 ms all channels
Noise suppression for frequency	>50dB at 50Hz (UCM<2V)	>90dB at 50Hz (UCM<10V)	>50dB at 50Hz (UCM<2V)	>50dB at 50Hz (UCM<2V)
<b>Status information, alarms, diagnostics</b>				
Status display	yes	yes	yes	yes
Interrupts	no	yes	no	no
Process alarm	no	yes, parameterizable	no	no
Diagnostic interrupt	no	yes, parameterizable	no	no
Diagnostic functions	yes	yes	yes	yes
Diagnostics information read-out	possible	possible	possible	possible
Module state	green LED	green LED	green LED	green LED
Module error display	red LED	red LED	red LED	red LED
Channel error display	red LED per channel	red LED per channel	red LED per channel	red LED per channel
<b>Isolation</b>				
Between channels	-	-	-	-
Between channels of groups to	-	-	-	-
Between channels and backplane bus	✓	✓	✓	✓

## Signal modules analog | Analog input modules

031-1BB10	031-1BB70	031-1BD70	031-1CB70	031-1LB90		
031-1BB30	031-1BB90	031-1BD80	031-1CD30	031-1LD80		
031-1BB40	031-1BD30	031-1CB30	031-1CD40			
031-1BB60	031-1BD40	031-1CB40	031-1CD70			

Order number	031-1BB70	031-1BB90	031-1BD30	031-1BD40
Between channels and power supply	✓	-	✓	✓
Max. potential difference between circuits	-	-	-	-
Max. potential difference between inputs (Ucm)	DC 2 V	DC 140 V/ AC 60 V	DC 2 V	DC 2 V
Max. potential difference between Mana and Mintern (Uiso)	-	-	-	-
Max. potential difference between inputs and Mana (Ucm)	-	-	-	-
Max. potential difference between inputs and Mintern (Uiso)	DC 75 V/ AC 60 V	DC 75 V/ AC 60 V	DC 75 V/ AC 60 V	DC 75 V/ AC 60 V
Max. potential difference between Mintern and outputs	-	-	-	-
Insulation tested with	DC 500 V	DC 500 V	DC 500 V	DC 500 V
<b>Datasizes</b>				
Input bytes	4	4	8	8
Output bytes	0	0	0	0
Parameter bytes	6	22	8	8
Diagnostic bytes	20	20	20	20
<b>Housing</b>				
Material	PPE / PPE GF10	PPE / PPE GF10	PPE / PPE GF10	PPE / PPE GF10
Mounting	Profile rail 35 mm	Profile rail 35 mm	Profile rail 35 mm	Profile rail 35 mm
<b>Mechanical data</b>				
Dimensions (WxHxD)	12.9 mm x 109 mm x 76.5 mm	12.9 mm x 109 mm x 76.5 mm	12.9 mm x 109 mm x 76.5 mm	12.9 mm x 109 mm x 76.5 mm
Weight	60 g	60 g	60 g	60 g
<b>Environmental conditions</b>				
Operating temperature	0 °C to 60 °C	0 °C to 60 °C	0 °C to 60 °C	0 °C to 60 °C
Storage temperature	-25 °C to 70 °C	-25 °C to 70 °C	-25 °C to 70 °C	-25 °C to 70 °C
<b>Certifications</b>				
UL508 certification	in preparation	yes	yes	yes

# Connections, Interfaces

Signal modules analog | Analog input modules

031-1BB10	031-1BB70	031-1BD70	031-1CB70	031-1LB90		
031-1BB30	031-1BB90	031-1BD80	031-1CD30	031-1LD80		
031-1BB40	031-1BD30	031-1CB30	031-1CD40			
031-1BB60	031-1BD40	031-1CB40	031-1CD70			

## 031-1BB70

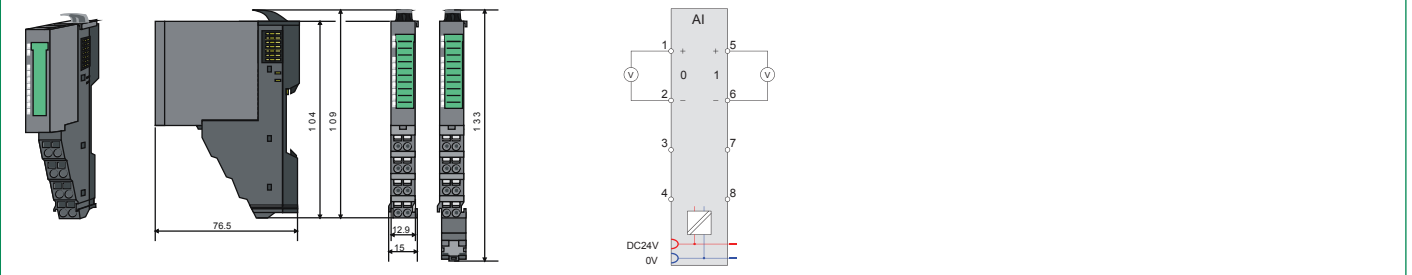

## 031-1BB90

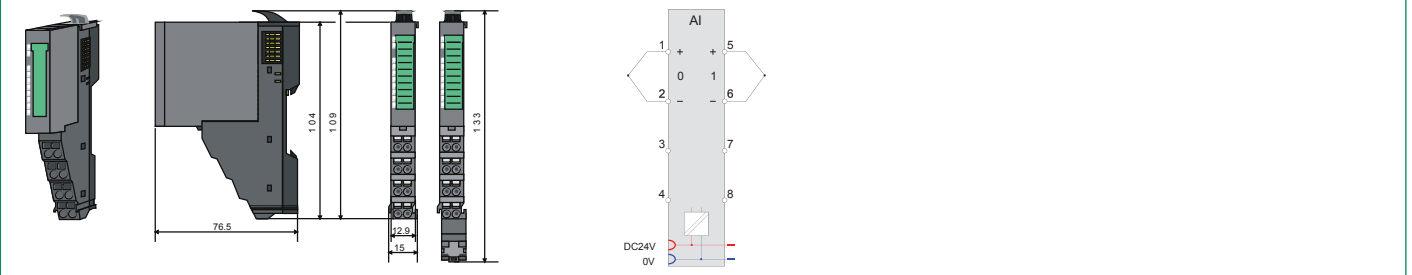

## 031-1BD30

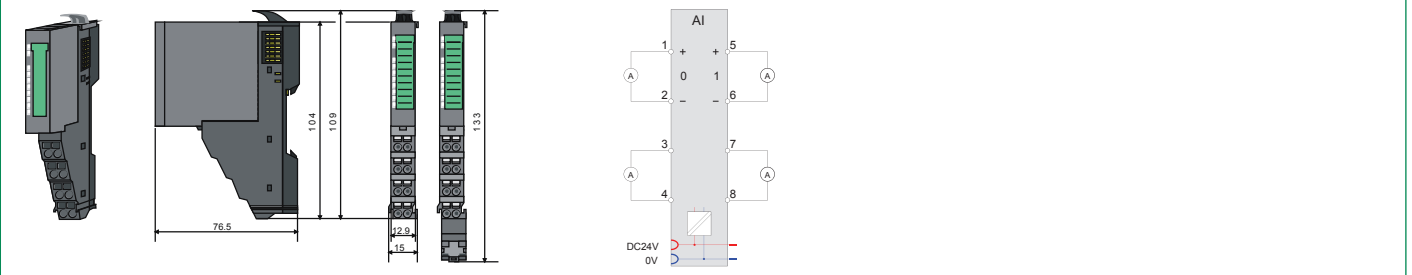



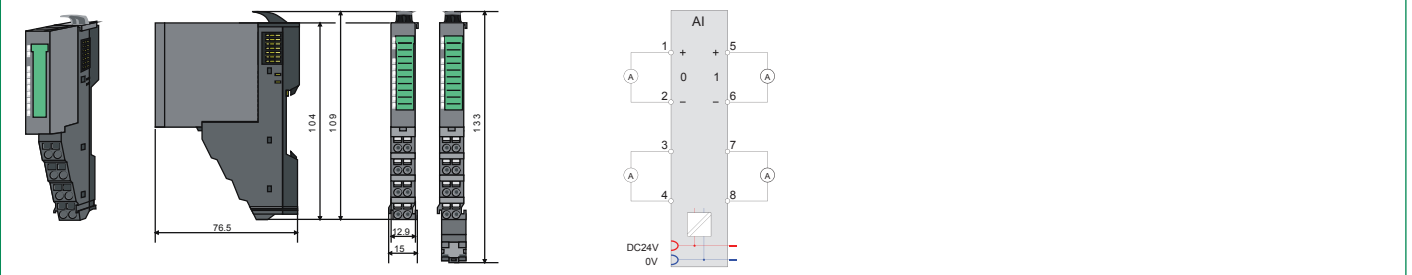

## 031-1BD40



# Analog input modules

## Signal modules analog | Analog input modules

031-1BB10	031-1BB70	031-1BD70	031-1CB70	031-1LB90		
031-1BB30	031-1BB90	031-1BD80	031-1CD30	031-1LD80		
031-1BB40	031-1BD30	031-1CB30	031-1CD40			
031-1BB60	031-1BD40	031-1CB40	031-1CD70			

Order number	031-1BD70	031-1BD80	031-1CB30	031-1CB40
Figure				
Type	SM 031	SM 031	SM 031	SM 031
Module ID	0409 15C4	0406 1544	040A 1543	040B 1543
<b>General information</b>				
Note	-	-	-	-
Features	<ul style="list-style-type: none"> <li>▶ 4 inputs 12Bit</li> <li>▶ Voltage -10 V...+10 V</li> </ul>	<ul style="list-style-type: none"> <li>▶ 4 inputs 16Bit</li> <li>▶ 0 .. 3000 ohm resistance</li> <li>▶ Resistance measurement with 2, 3, and 4-wires</li> </ul>	<ul style="list-style-type: none"> <li>▶ 2 inputs 16Bit</li> <li>▶ Voltage 0...10 V</li> </ul>	<ul style="list-style-type: none"> <li>▶ 2 inputs 16Bit</li> <li>▶ Current 0(4)...20 mA</li> </ul>
<b>Current consumption/power loss</b>				
Current consumption from backplane bus	50 mA	75 mA	60 mA	60 mA
Power loss	0.5 W	1 W	0.8 W	0.7 W
<b>Technical data analog inputs</b>				
Number of inputs	4	4	2	2
Cable length, shielded	200 m	200 m	200 m	200 m
Rated load voltage	DC 24 V	DC 24 V	DC 24 V	DC 24 V
Current consumption from load voltage L+ (without load)	15 mA	30 mA	20 mA	15 mA
Voltage inputs	✓	-	✓	-
Min. input resistance (voltage range)	100 kΩ	-	200 kΩ	-
Input voltage ranges	-10 V ... +10 V	-	0 V ... +10 V	-
Operational limit of voltage ranges	+/-0.3%	-	+/-0.2%	-
Operational limit of voltage ranges with SFU	-	-	-	-
Basic error limit voltage ranges	+/-0.2%	-	+/-0.1%	-
Basic error limit voltage ranges with SFU	-	-	-	-
Current inputs	-	-	-	✓
Min. input resistance (current range)	-	-	-	60 Ω
Input current ranges	-	-	-	0 mA ... +20 mA +4 mA ... +20 mA
Operational limit of current ranges	-	-	-	+/-0.2%
Operational limit of current ranges with SFU	-	-	-	-
Basic error limit current ranges	-	-	-	+/-0.1%
Basic error limit current ranges with SFU	-	-	-	-
Resistance inputs	-	✓	-	-
Resistance ranges	-	0 ... 60 Ohm 0 ... 600 Ohm 0 ... 3000 Ohm	-	-
Operational limit of resistor ranges	-	+/- 0.4 %	-	-
Basic error limit	-	+/- 0.2 %	-	-
Resistance thermometer inputs	-	✓	-	-

Signal modules analog   Analog input modules						
031-1BB10	031-1BB70	031-1BD70	031-1CB70	031-1LB90		
031-1BB30	031-1BB90	031-1BD80	031-1CD30	031-1LD80		
031-1BB40	031-1BD30	031-1CB30	031-1CD40			
031-1BB60	031-1BD40	031-1CB40	031-1CD70			

Order number	031-1BD70	031-1BD80	031-1CB30	031-1CB40
Resistance thermometer ranges	-	Pt100 Pt1000 Ni100 Ni1000	-	-
Operational limit of resistance thermometer ranges	-	+/- 0.4 %	-	-
Operational limit of resistor ranges with SFU	-	-	-	-
Basic error limit thermoresistor ranges	-	+/- 0.2 %	-	-
Operational limit of resistor ranges with SFU	-	-	-	-
Thermocouple inputs	-	-	-	-
Thermocouple ranges	-	-	-	-
Operational limit of thermocouple ranges	-	-	-	-
Operational limit of thermocouple ranges with SFU	-	-	-	-
Basic error limit thermoelement ranges	-	-	-	-
Basic error limit thermoelement ranges with SFU	-	-	-	-
Programmable temperature compensation	-	-	-	-
External temperature compensation	-	-	-	-
Internal temperature compensation	-	-	-	-
Resolution in bit	12	16	16	16
Measurement principle	successive approximation	Sigma-Delta	successive approximation	successive approximation
Basic conversion time	4 ms all channels	4.2...324.1 ms (50 Hz) 3.8...270.5 ms (60 Hz) per channel	240 µs all channels	240 µs all channels
Noise suppression for frequency	>50dB at 50Hz (UCM<2V)	>80dB at 50Hz (UCM<6V)	>80dB at 50Hz (UCM<9V)	>80dB (UCM<4V)
<b>Status information, alarms, diagnostics</b>				
Status display	yes	yes	yes	yes
Interrupts	no	yes, parameterizable	yes, parameterizable	yes, parameterizable
Process alarm	no	yes, parameterizable	yes, parameterizable	yes, parameterizable
Diagnostic interrupt	no	yes, parameterizable	yes, parameterizable	yes, parameterizable
Diagnostic functions	yes	yes	yes	yes
Diagnostics information read-out	possible	possible	possible	possible
Module state	green LED	green LED	green LED	green LED
Module error display	red LED	red LED	red LED	red LED
Channel error display	red LED per channel	red LED per channel	red LED per channel	red LED per channel
<b>Isolation</b>				
Between channels	-	-	-	-
Between channels of groups to	-	-	-	-
Between channels and backplane bus	✓	✓	✓	✓
Between channels and power supply	✓	-	✓	✓
Max. potential difference between circuits	-	-	-	-
Max. potential difference between inputs (Ucm)	DC 2 V	DC 6 V	DC 9 V	DC 4 V
Max. potential difference between Mana and Mintern (Uiso)	-	-	-	-

Signal modules analog   Analog input modules						
031-1BB10	031-1BB70	031-1BD70	031-1CB70	031-1LB90		
031-1BB30	031-1BB90	031-1BD80	031-1CD30	031-1LD80		
031-1BB40	031-1BD30	031-1CB30	031-1CD40			
031-1BB60	031-1BD40	031-1CB40	031-1CD70			

Order number	031-1BD70	031-1BD80	031-1CB30	031-1CB40
Max. potential difference between inputs and Mana (Ucm)	-	-	-	-
Max. potential difference between inputs and Mintern (Uiso)	DC 75 V/ AC 60 V	DC 75 V/ AC 60 V	DC 75 V/ AC 60 V	DC 75 V/ AC 60 V
Max. potential difference between Mintern and outputs	-	-	-	-
Insulation tested with	DC 500 V	DC 500 V	DC 500 V	DC 500 V
<b>Datasizes</b>				
Input bytes	8	8	4	4
Output bytes	0	0	0	0
Parameter bytes	8	34	20	20
Diagnostic bytes	20	20	20	20
<b>Housing</b>				
Material	PPE / PPE GF10	PPE / PPE GF10	PPE / PPE GF10	PPE / PPE GF10
Mounting	Profile rail 35 mm	Profile rail 35 mm	Profile rail 35 mm	Profile rail 35 mm
<b>Mechanical data</b>				
Dimensions (WxHxD)	12.9 mm x 109 mm x 76.5 mm	12.9 mm x 109 mm x 76.5 mm	12.9 mm x 109 mm x 76.5 mm	12.9 mm x 109 mm x 76.5 mm
Weight	60 g	60 g	60 g	60 g
<b>Environmental conditions</b>				
Operating temperature	0 °C to 60 °C	0 °C to 60 °C	0 °C to 60 °C	0 °C to 60 °C
Storage temperature	-25 °C to 70 °C	-25 °C to 70 °C	-25 °C to 70 °C	-25 °C to 70 °C
<b>Certifications</b>				
UL508 certification	in preparation	yes	in preparation	in preparation

# Connections, Interfaces

Signal modules analog | Analog input modules

031-1BB10	031-1BB70	031-1BD70	031-1CB70	031-1LB90	
031-1BB30	031-1BB90	031-1BD80	031-1CD30	031-1LD80	
031-1BB40	031-1BD30	031-1CB30	031-1CD40		
031-1BB60	031-1BD40	031-1CB40	031-1CD70		

## 031-1BD70

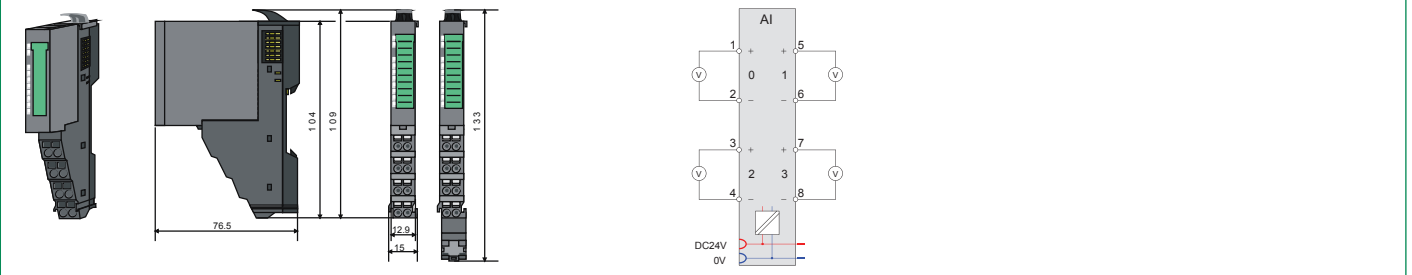

## 031-1BD80

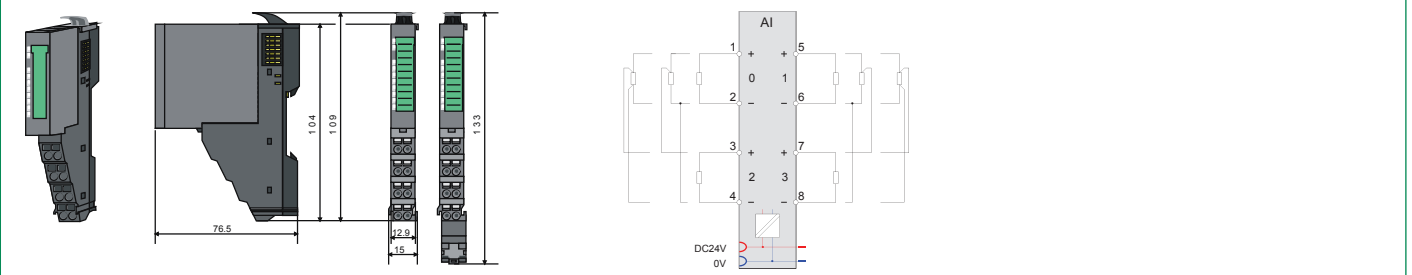

## 031-1CB30

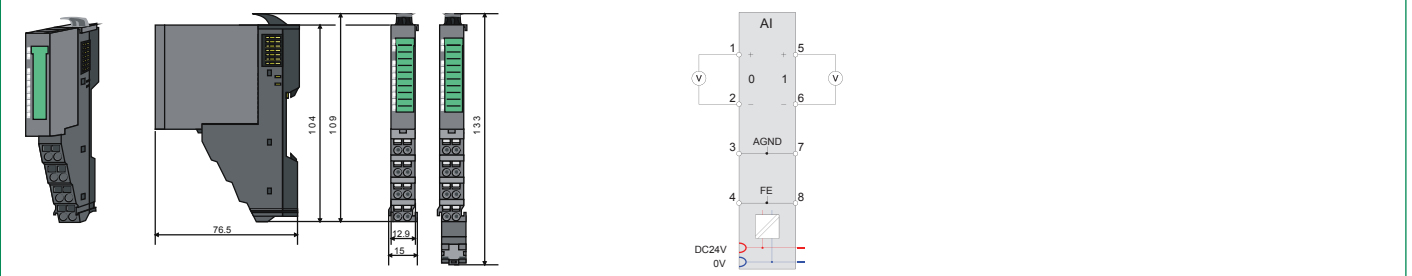



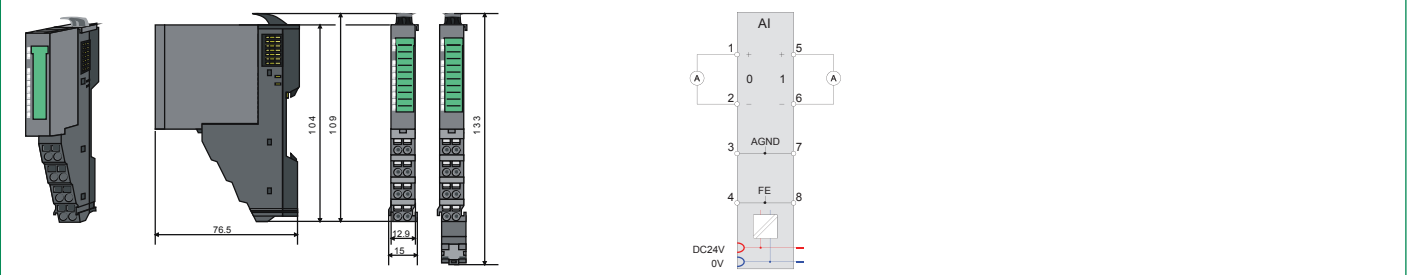

## 031-1CB40



# Analog input modules

Signal modules analog   Analog input modules						
031-1BB10	031-1BB70	031-1BD70	031-1CB70	031-1LB90		
031-1BB30	031-1BB90	031-1BD80	031-1CD30	031-1LD80		
031-1BB40	031-1BD30	031-1CB30	031-1CD40			
031-1BB60	031-1BD40	031-1CB40	031-1CD70			

Order number	031-1CB70	031-1CD30	031-1CD40	031-1CD70
Figure				
Type	SM 031	SM 031	SM 031	SM 031
Module ID	040C 1543	040D 1544	0411 1544	040E 1544
<b>General information</b>				
Note	-	-	-	-
Features	<ul style="list-style-type: none"> <li>2 inputs 16Bit</li> <li>Voltage -10 V...+10 V</li> </ul>	<ul style="list-style-type: none"> <li>4 inputs 16Bit</li> <li>Voltage 0...10 V</li> </ul>	<ul style="list-style-type: none"> <li>4 inputs 16Bit</li> <li>Current 0(4)...20 mA</li> </ul>	<ul style="list-style-type: none"> <li>4 inputs 16Bit</li> <li>Voltage -10 V...+10 V</li> </ul>
<b>Current consumption/power loss</b>				
Current consumption from backplane bus	60 mA	60 mA	60 mA	60 mA
Power loss	0.8 W	0.9 W	0.8 W	0.9 W
<b>Technical data analog inputs</b>				
Number of inputs	2	4	4	4
Cable length, shielded	200 m	200 m	200 m	200 m
Rated load voltage	DC 24 V	DC 24 V	DC 24 V	DC 24 V
Current consumption from load voltage L+ (without load)	20 mA	25 mA	20 mA	25 mA
Voltage inputs	✓	✓	-	✓
Min. input resistance (voltage range)	200 kΩ	200 kΩ	-	200 kΩ
Input voltage ranges	-10 V ... +10 V	0 V ... +10 V	-	-10 V ... +10 V
Operational limit of voltage ranges	+/-0.2%	+/-0.2%	-	+/-0.2%
Operational limit of voltage ranges with SFU	-	-	-	-
Basic error limit voltage ranges	+/-0.1%	+/-0.1%	-	+/-0.1%
Basic error limit voltage ranges with SFU	-	-	-	-
Current inputs	-	-	✓	-
Min. input resistance (current range)	-	-	60 Ω	-
Input current ranges	-	-	0 mA ... +20 mA +4 mA ... +20 mA	-
Operational limit of current ranges	-	-	+/-0.2%	-
Operational limit of current ranges with SFU	-	-	-	-
Basic error limit current ranges	-	-	+/-0.1%	-
Basic error limit current ranges with SFU	-	-	-	-
Resistance inputs	-	-	-	-
Resistance ranges	-	-	-	-
Operational limit of resistor ranges	-	-	-	-
Basic error limit	-	-	-	-
Resistance thermometer inputs	-	-	-	-
Resistance thermometer ranges	-	-	-	-
Operational limit of resistance thermometer ranges	-	-	-	-
Operational limit of resistor ranges with SFU	-	-	-	-

Signal modules analog   Analog input modules						
031-1BB10	031-1BB70	031-1BD70	031-1CB70	031-1LB90		
031-1BB30	031-1BB90	031-1BD80	031-1CD30	031-1LD80		
031-1BB40	031-1BD30	031-1CB30	031-1CD40			
031-1BB60	031-1BD40	031-1CB40	031-1CD70			

Order number	031-1CB70	031-1CD30	031-1CD40	031-1CD70
Basic error limit thermoresistor ranges	-	-	-	-
Operational limit of resistor ranges with SFU	-	-	-	-
Thermocouple inputs	-	-	-	-
Thermocouple ranges	-	-	-	-
Operational limit of thermocouple ranges	-	-	-	-
Operational limit of thermocouple ranges with SFU	-	-	-	-
Basic error limit thermoelement ranges	-	-	-	-
Basic error limit thermoelement ranges with SFU	-	-	-	-
Programmable temperature compensation	-	-	-	-
External temperature compensation	-	-	-	-
Internal temperature compensation	-	-	-	-
Resolution in bit	16	16	16	16
Measurement principle	successive approximation	successive approximation	successive approximation	successive approximation
Basic conversion time	240 µs all channels	480 µs all channels	240 µs all channels	480 µs all channels
Noise suppression for frequency	>80dB at 50Hz (UCM<9V)	>80dB at 50Hz (UCM<9V)	>80dB (UCM<4V)	>80dB at 50Hz (UCM<35V)
Status information, alarms, diagnostics				
Status display	yes	yes	yes	yes
Interrupts	yes, parameterizable	yes, parameterizable	yes, parameterizable	yes, parameterizable
Process alarm	yes, parameterizable	yes, parameterizable	yes, parameterizable	yes, parameterizable
Diagnostic interrupt	yes, parameterizable	yes, parameterizable	yes, parameterizable	yes, parameterizable
Diagnostic functions	yes	yes	yes	yes
Diagnostics information read-out	possible	possible	possible	possible
Module state	green LED	green LED	green LED	green LED
Module error display	red LED	red LED	red LED	red LED
Channel error display	red LED per channel	red LED per channel	red LED per channel	red LED per channel
Isolation				
Between channels	-	-	-	-
Between channels of groups to	-	-	-	-
Between channels and backplane bus	✓	✓	✓	✓
Between channels and power supply	✓	✓	✓	✓
Max. potential difference between circuits	-	-	-	-
Max. potential difference between inputs (Ucm)	DC 9 V	DC 9 V	DC 4 V	DC 9 V
Max. potential difference between Mana and Mintern (Uiso)	-	-	-	-
Max. potential difference between inputs and Mana (Ucm)	-	-	-	-
Max. potential difference between inputs and Mintern (Uiso)	DC 75 V/ AC 60 V	DC 75 V/ AC 60 V	DC 75 V/ AC 60 V	DC 75 V/ AC 60 V
Max. potential difference between Mintern and outputs	-	-	-	-
Insulation tested with	DC 500 V	DC 500 V	DC 500 V	DC 500 V

Signal modules analog | Analog input modules

031-1BB10	031-1BB70	031-1BD70	031-1CB70	031-1LB90		
031-1BB30	031-1BB90	031-1BD80	031-1CD30	031-1LD80		
031-1BB40	031-1BD30	031-1CB30	031-1CD40			
031-1BB60	031-1BD40	031-1CB40	031-1CD70			

Order number	031-1CB70	031-1CD30	031-1CD40	031-1CD70
<b>Datasizes</b>				
Input bytes	4	8	4	8
Output bytes	0	0	0	0
Parameter bytes	20	32	32	32
Diagnostic bytes	20	20	20	20
<b>Housing</b>				
Material	PPE / PPE GF10	PPE / PPE GF10	PPE / PPE GF10	PPE / PPE GF10
Mounting	Profile rail 35 mm	Profile rail 35 mm	Profile rail 35 mm	Profile rail 35 mm
<b>Mechanical data</b>				
Dimensions (WxHxD)	12.9 mm x 109 mm x 76.5 mm	12.9 mm x 109 mm x 76.5 mm	12.9 mm x 109 mm x 76.5 mm	12.9 mm x 109 mm x 76.5 mm
Weight	60 g	60 g	60 g	60 g
<b>Environmental conditions</b>				
Operating temperature	0 °C to 60 °C	0 °C to 60 °C	0 °C to 60 °C	0 °C to 60 °C
Storage temperature	-25 °C to 70 °C	-25 °C to 70 °C	-25 °C to 70 °C	-25 °C to 70 °C
<b>Certifications</b>				
UL508 certification	in preparation	in preparation	in preparation	in preparation

# Connections, Interfaces

Signal modules analog | Analog input modules

031-1BB10	031-1BB70	031-1BD70	031-1CB70	031-1LB90		
031-1BB30	031-1BB90	031-1BD80	031-1CD30	031-1LD80		
031-1BB40	031-1BD30	031-1CB30	031-1CD40			
031-1BB60	031-1BD40	031-1CB40	031-1CD70			

## 031-1CB70

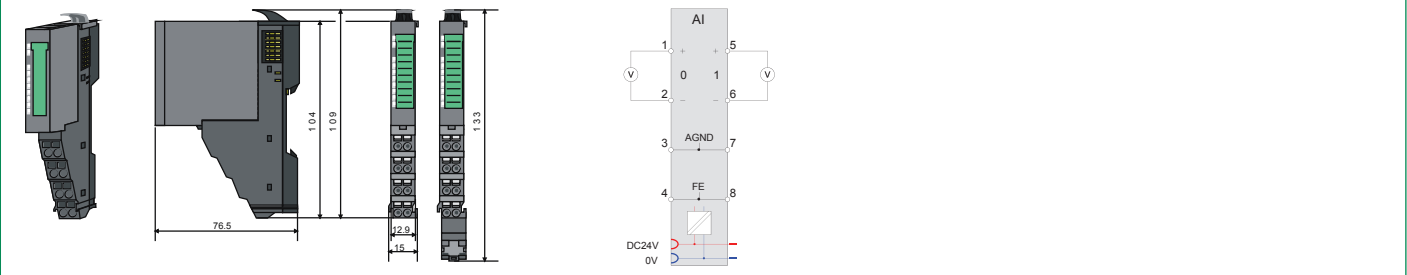

## 031-1CD30

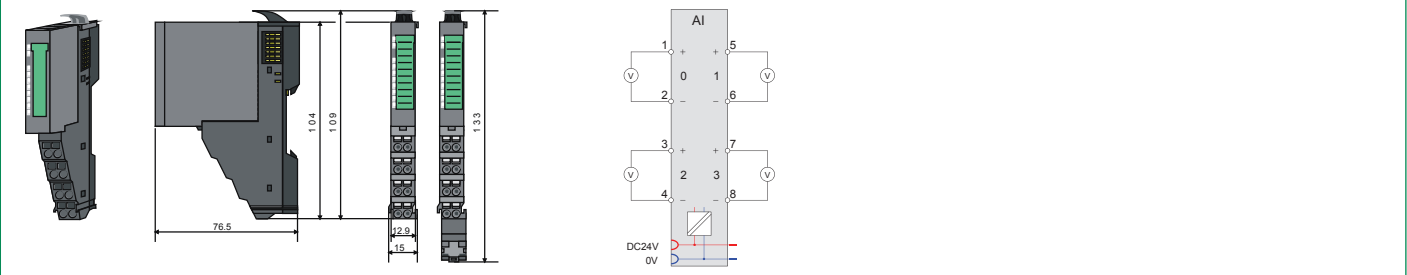

## 031-1CD40

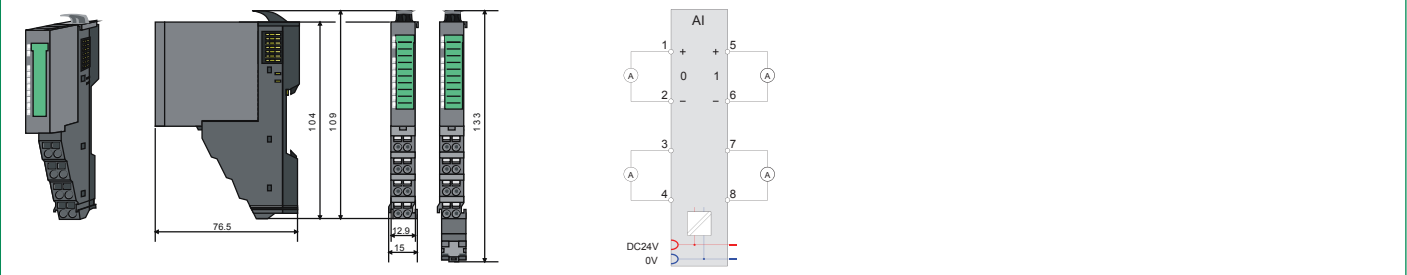

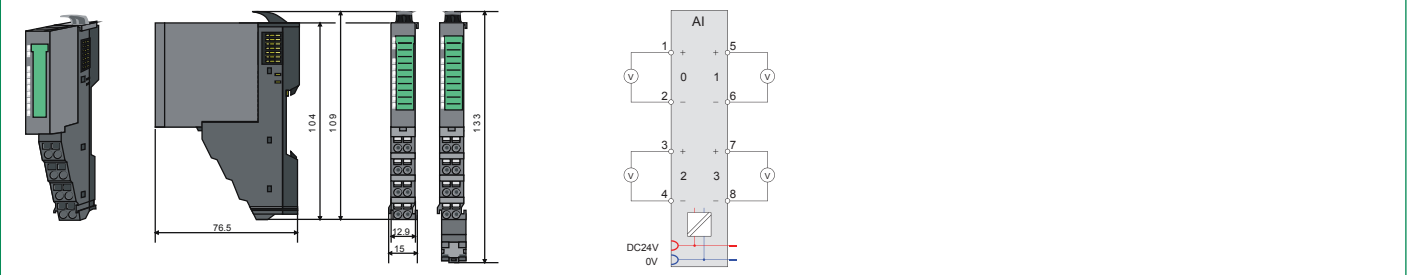

## 031-1CD70



# Analog input modules

Signal modules analog   Analog input modules						
031-1BB10	031-1BB70	031-1BD70	031-1CB70	031-1LB90 031-1LD80		
031-1BB30	031-1BB90	031-1BD80	031-1CD30			
031-1BB40	031-1BD30	031-1CB30	031-1CD40			
031-1BB60	031-1BD40	031-1CB40	031-1CD70			

Order number	031-1LB90	031-1LD80		
Figure				
Type	SM 031	SM 031		
Module ID	040F 1543	0410 1544		
General information				
Note	-	-		
Features	<ul style="list-style-type: none"> <li>› 2 inputs 16Bit</li> <li>› Thermocouple</li> <li>› Voltage -80mV...+80mV</li> </ul>	<ul style="list-style-type: none"> <li>› 4 inputs 16Bit</li> <li>› 0 .. 3000 ohm resistance</li> <li>› Resistance measurement with 2, 3, and 4-wires</li> </ul>		
Current consumption/power loss				
Current consumption from backplane bus	55 mA	55 mA		
Power loss	1 W	1 W		
Technical data analog inputs				
Number of inputs	2	4		
Cable length, shielded	200 m	200 m		
Rated load voltage	DC 24 V	DC 24 V		
Current consumption from load voltage L+ (without load)	30 mA	30 mA		
Voltage inputs	-	-		
Min. input resistance (voltage range)	10 MΩ	-		
Input voltage ranges	-80 mV ... +80 mV	-		
Operational limit of voltage ranges	±0.3%	-		
Operational limit of voltage ranges with SFU	±0.1%	-		
Basic error limit voltage ranges	±0.25%	-		
Basic error limit voltage ranges with SFU	±0.05%	-		
Current inputs	-	-		
Min. input resistance (current range)	-	-		
Input current ranges	-	-		
Operational limit of current ranges	-	-		
Operational limit of current ranges with SFU	-	-		
Basic error limit current ranges	-	-		
Basic error limit current ranges with SFU	-	-		
Resistance inputs	-	✓		
Resistance ranges	-	0 ... 60 Ohm 0 ... 600 Ohm 0 ... 3000 Ohm		
Operational limit of resistor ranges	-	+/- 0.4 %		
Basic error limit	-	+/- 0.2 %		
Resistance thermometer inputs	-	✓		

Signal modules analog   Analog input modules						
031-1BB10	031-1BB70	031-1BD70	031-1CB70	031-1LB90 031-1LD80		
031-1BB30	031-1BB90	031-1BD80	031-1CD30			
031-1BB40	031-1BD30	031-1CB30	031-1CD40			
031-1BB60	031-1BD40	031-1CB40	031-1CD70			

Order number	031-1LB90	031-1LD80		
Resistance thermometer ranges	-	Pt100 Pt1000 Ni100 Ni1000		
Operational limit of resistance thermometer ranges	-	+/- 0.4 %		
Operational limit of resistor ranges with SFU	-	-		
Basic error limit thermoresistor ranges	-	+/- 0.2 %		
Operational limit of resistor ranges with SFU	-	-		
Thermocouple inputs	✓	-		
Thermocouple ranges	type B type C type E type J type K type L type N type R type S type T	-		
Operational limit of thermocouple ranges	Type E, L, T, J, K, N: ±2.5K / Type B, C, R, S: ±8.0K	-		
Operational limit of thermocouple ranges with SFU	Type E, L, T, J, K, N: ±1.5K / Type B, C, R, S: ±4.0K	-		
Basic error limit thermoelement ranges	Type E, L, T, J, K, N: ±2.0K / Type B, C, R, S: ±7.0K	-		
Basic error limit thermoelement ranges with SFU	Type E, L, T, J, K, N: ±1.0K / Type B, C, R, S: ±3.0K	-		
Programmable temperature compensation	✓	-		
External temperature compensation	✓	-		
Internal temperature compensation	✓	-		
Resolution in bit	16	16		
Measurement principle	Sigma-Delta	Sigma-Delta		
Basic conversion time	84.2 ms (50 Hz) 70.5 ms (60 Hz) per channel	4.2...324.1 ms (50 Hz) 3.8...270.5 ms (60 Hz) per channel		
Noise suppression for frequency	>90dB at 50Hz (UCM<10V)	>80dB at 50Hz (UCM<6V)		
<b>Status information, alarms, diagnostics</b>				
Status display	yes	yes		
Interrupts	yes	yes, parameterizable		
Process alarm	no	no		
Diagnostic interrupt	yes, parameterizable	yes, parameterizable		
Diagnostic functions	yes	yes		
Diagnostics information read-out	possible	possible		
Module state	green LED	green LED		
Module error display	red LED	red LED		
Channel error display	red LED per channel	red LED per channel		

Signal modules analog   Analog input modules						
031-1BB10	031-1BB70	031-1BD70	031-1CB70	031-1LB90		
031-1BB30	031-1BB90	031-1BD80	031-1CD30	031-1LD80		
031-1BB40	031-1BD30	031-1CB30	031-1CD40			
031-1BB60	031-1BD40	031-1CB40	031-1CD70			

Order number	031-1LB90	031-1LD80		
<b>Isolation</b>				
Between channels	-	-		
Between channels of groups to	-	-		
Between channels and backplane bus	✓	✓		
Between channels and power supply	-	-		
Max. potential difference between circuits	-	-		
Max. potential difference between inputs (Ucm)	DC 140 V/ AC 60 V	DC 6 V		
Max. potential difference between Mana and Mintern (Uiso)	-	-		
Max. potential difference between inputs and Mana (Ucm)	-	-		
Max. potential difference between inputs and Mintern (Uiso)	DC 75 V/ AC 60 V	DC 75 V/ AC 60 V		
Max. potential difference between Mintern and outputs	-	-		
Insulation tested with	DC 500 V	DC 500 V		
<b>Datasizes</b>				
Input bytes	4	8		
Output bytes	0	0		
Parameter bytes	10	12		
Diagnostic bytes	20	20		
<b>Housing</b>				
Material	PPE / PPE GF10	PPE / PPE GF10		
Mounting	Profile rail 35 mm	Profile rail 35 mm		
<b>Mechanical data</b>				
Dimensions (WxHxD)	12.9 mm x 109 mm x 76.5 mm	12.9 mm x 109 mm x 76.5 mm		
Weight	60 g	60 g		
<b>Environmental conditions</b>				
Operating temperature	0 °C to 60 °C	0 °C to 60 °C		
Storage temperature	-25 °C to 70 °C	-25 °C to 70 °C		
<b>Certifications</b>				
UL508 certification	in preparation	in preparation		

# Connections, Interfaces

Signal modules analog | Analog input modules

031-1BB10	031-1BB70	031-1BD70	031-1CB70	031-1LB90 031-1LD80		
031-1BB30	031-1BB90	031-1BD80	031-1CD30			
031-1BB40	031-1BD30	031-1CB30	031-1CD40			
031-1BB60	031-1BD40	031-1CB40	031-1CD70			

**031-1LB90**

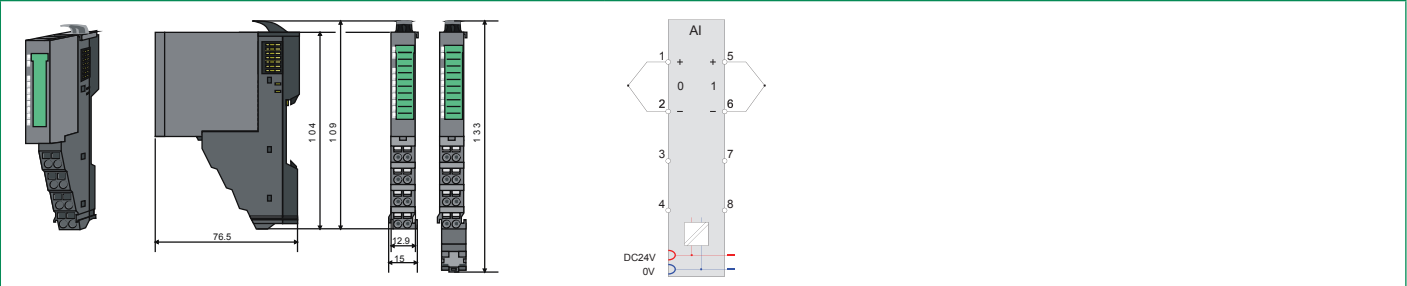



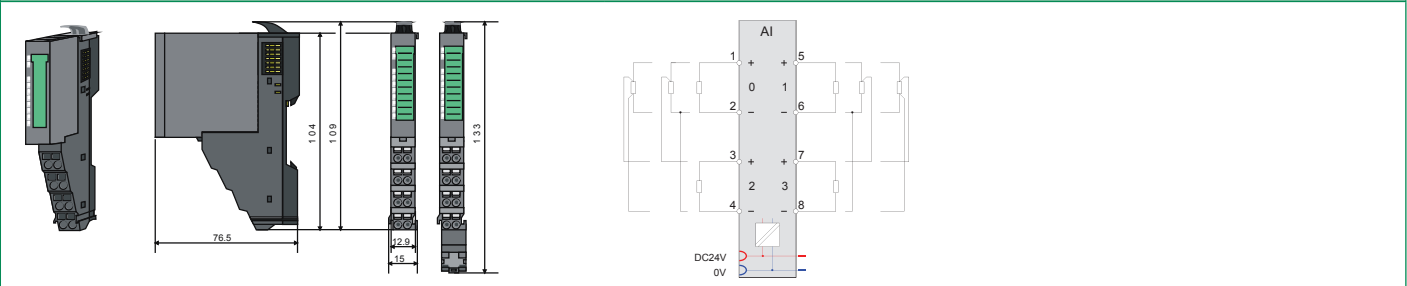

**031-1LD80**



# Analog output modules

## Signal modules analog | Analog output modules

032-1BB30	032-1BD40	032-1CD30			
032-1BB40	032-1BD70	032-1CD70			
032-1BB70	032-1CB30				
032-1BD30	032-1CB70				

Order number	032-1BB30	032-1BB40	032-1BB70	032-1BD30
Figure				
Type	SM 032	SM 032	SM 032	SM 032
Module ID	0501 25D8	0502 25D8	0505 25D8	0503 25E0
<b>General information</b>				
Note	-	-	-	-
Features	<ul style="list-style-type: none"> <li>▸ 2 outputs 12Bit</li> <li>▸ Voltage 0...10 V</li> </ul>	<ul style="list-style-type: none"> <li>▸ 2 outputs 12Bit</li> <li>▸ Current 0(4)...20 mA</li> </ul>	<ul style="list-style-type: none"> <li>▸ 2 outputs 12Bit</li> <li>▸ Voltage -10 V...+10 V</li> </ul>	<ul style="list-style-type: none"> <li>▸ 4 outputs 12Bit</li> <li>▸ Voltage 0...10 V</li> </ul>
<b>Current consumption/power loss</b>				
Current consumption from backplane bus	80 mA	80 mA	60 mA	80 mA
Power loss	1.2 W	0.8 W	0.8 W	1.2 W
<b>Technical data analog outputs</b>				
Number of outputs	2	2	2	4
Cable length, shielded	200 m	200 m	200 m	200 m
Rated load voltage	DC 24 V	DC 24 V	DC 24 V	DC 24 V
Current consumption from load voltage L+ (without load)	-	-	-	-
Voltage output short-circuit protection	✓	-	✓	✓
Voltage outputs	✓	-	✓	✓
Min. load resistance (voltage range)	5 kΩ	-	5 kΩ	5 kΩ
Max. capacitive load (current range)	1 μF	-	1 μF	1 μF
Output voltage ranges	0 V ... +10 V	-	-10 V ... +10 V	0 V ... +10 V
Operational limit of voltage ranges	+/-0.3%	-	+/-0.3%	+/-0.3%
Basic error limit voltage ranges with SFU	+/-0.2%	-	+/-0.2%	+/-0.2%
Current outputs	-	✓	-	-
Max. in load resistance (current range)	-	350 Ω	-	-
Max. inductive load (current range)	-	10 mH	-	-
Output current ranges	-	0 mA ... +20 mA +4 mA ... +20 mA	-	-
Operational limit of current ranges	-	+/-0.4% ... +/-0.5%	-	-
Basic error limit current ranges with SFU	-	+/-0.2% ... +/-0.3%	-	-
Settling time for ohmic load	1.5 ms	0.25 ms	1.5 ms	1.5 ms
Settling time for capacitive load	2 ms	-	2 ms	2 ms
Settling time for inductive load	-	1.5 ms	-	-
Resolution in bit	12	12	12	12
Conversion time	2 ms all channels	2 ms all channels	2 ms all channels	2 ms all channels
Substitute value can be applied	no	no	no	no
<b>Status information, alarms, diagnostics</b>				
Status display	yes	yes	yes	yes
Interrupts	no	no	no	no
Process alarm	no	no	no	no
Diagnostic interrupt	no	no	no	no
Diagnostic functions	yes	yes	yes	yes

Signal modules analog   Analog output modules						
032-1BB30	032-1BD40	032-1CD30				
032-1BB40	032-1BD70	032-1CD70				
032-1BB70	032-1CB30					
032-1BD30	032-1CB70					

Order number	032-1BB30	032-1BB40	032-1BB70	032-1BD30
Diagnostics information read-out	possible	possible	possible	possible
Module state	green LED	green LED	green LED	green LED
Module error display	red LED	red LED	red LED	red LED
Channel error display	red LED per channel	red LED per channel	red LED per channel	red LED per channel
<b>Isolation</b>				
Between channels	-	-	-	-
Between channels of groups to	-	-	-	-
Between channels and backplane bus	✓	✓	✓	✓
Between channels and power supply	✓	✓	✓	✓
Max. potential difference between circuits	-	-	-	-
Max. potential difference between inputs (Ucm)	-	-	-	-
Max. potential difference between Mana and Mintern (Uiso)	DC 75 V/ AC 60 V	DC 75 V/ AC 60 V	DC 75 V/ AC 60 V	DC 75 V/ AC 60 V
Max. potential difference between inputs and Mana (Ucm)	-	-	-	-
Max. potential difference between inputs and Mintern (Uiso)	-	-	-	-
Max. potential difference between Mintern and outputs	-	-	-	-
Insulation tested with	DC 500 V	DC 500 V	DC 500 V	DC 500 V
<b>Datasizes</b>				
Input bytes	0	0	0	0
Output bytes	4	4	4	8
Parameter bytes	8	8	8	10
Diagnostic bytes	20	20	20	20
<b>Housing</b>				
Material	PPE / PPE GF10	PPE / PPE GF10	PPE / PPE GF10	PPE / PPE GF10
Mounting	Profile rail 35 mm	Profile rail 35 mm	Profile rail 35 mm	Profile rail 35 mm
<b>Mechanical data</b>				
Dimensions (WxHxD)	12.9 mm x 109 mm x 76.5 mm	12.9 mm x 109 mm x 76.5 mm	12.9 mm x 109 mm x 76.5 mm	12.9 mm x 109 mm x 76.5 mm
Weight	60 g	60 g	60 g	60 g
<b>Environmental conditions</b>				
Operating temperature	0 °C to 60 °C	0 °C to 60 °C	0 °C to 60 °C	0 °C to 60 °C
Storage temperature	-25 °C to 70 °C	-25 °C to 70 °C	-25 °C to 70 °C	-25 °C to 70 °C
<b>Certifications</b>				
UL508 certification	yes	yes	in preparation	yes

# Connections, Interfaces

Signal modules analog | Analog output modules

032-1BB30	032-1BD40	032-1CD30			
032-1BB40	032-1BD70	032-1CD70			
032-1BB70	032-1CB30				
032-1BD30	032-1CB70				

032-1BB30

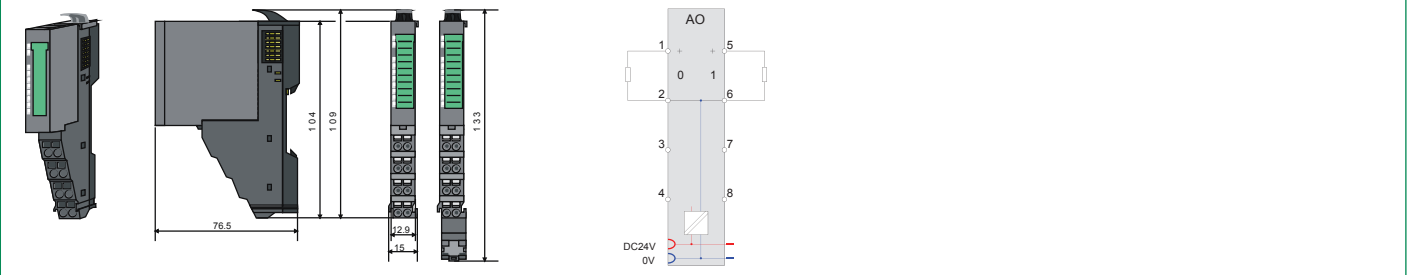

032-1BB40

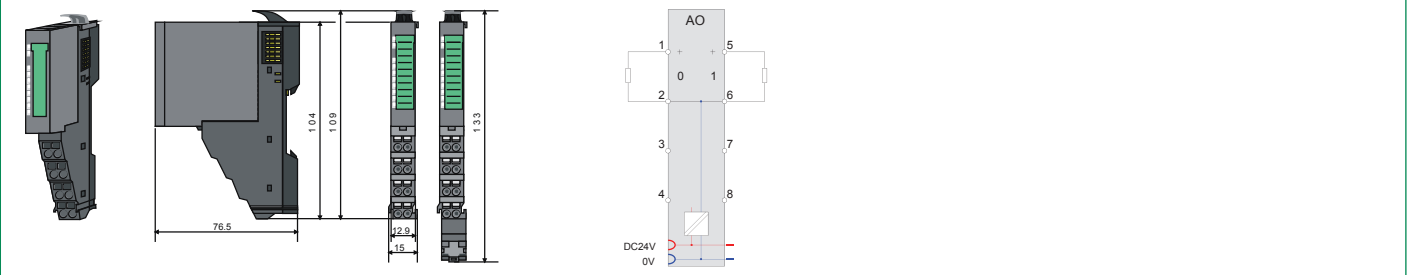

032-1BB70

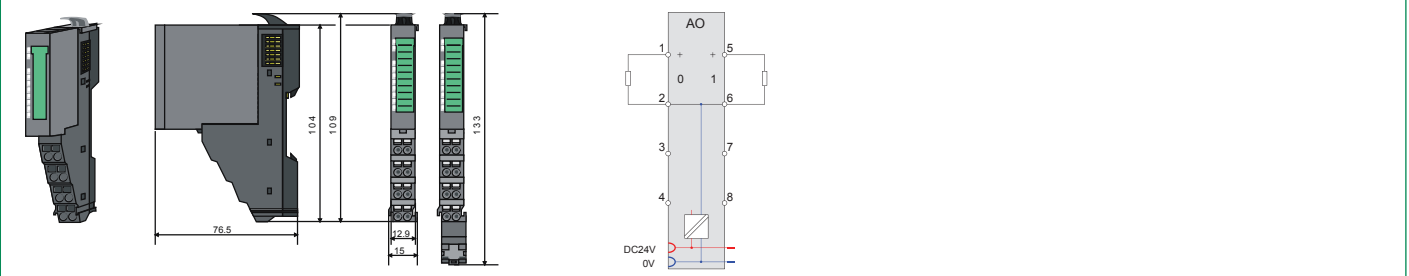



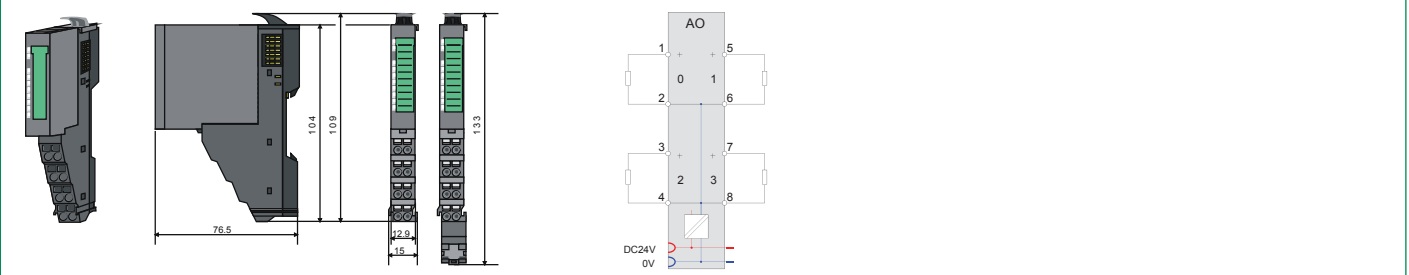

032-1BD30



# Analog output modules

## Signal modules analog | Analog output modules

032-1BB30	032-1BD40	032-1CD30			
032-1BB40	032-1BD70	032-1CD70			
032-1BB70	032-1CB30				
032-1BD30	032-1CB70				

Order number	032-1BD40	032-1BD70	032-1CB30	032-1CB70
Figure				
Type	SM 032	SM 032	SM 032	SM 032
Module ID	0504 25E0	0506 25E0	0507 2558	0508 2558
<b>General information</b>				
Note	-	-	-	-
Features	<ul style="list-style-type: none"> <li>▸ 4 outputs 12Bit</li> <li>▸ Current 0(4)...20mA</li> </ul>	<ul style="list-style-type: none"> <li>▸ 4 outputs 12Bit</li> <li>▸ Voltage -10 V...+10 V</li> </ul>	<ul style="list-style-type: none"> <li>▸ 2 outputs 16Bit</li> <li>▸ Voltage 0...+10 V</li> </ul>	<ul style="list-style-type: none"> <li>▸ 2 outputs 16Bit</li> <li>▸ Voltage -10 V...+10 V</li> </ul>
<b>Current consumption/power loss</b>				
Current consumption from backplane bus	80 mA	60 mA	60 mA	60 mA
Power loss	0.8 W	0.8 W	0.8 W	0.8 W
<b>Technical data analog outputs</b>				
Number of outputs	4	4	2	2
Cable length, shielded	200 m	200 m	200 m	200 m
Rated load voltage	DC 24 V	DC 24 V	DC 24 V	DC 24 V
Current consumption from load voltage L+ (without load)	-	-	-	-
Voltage output short-circuit protection	-	✓	✓	✓
Voltage outputs	-	✓	✓	✓
Min. load resistance (voltage range)	-	5 kΩ	5 kΩ	5 kΩ
Max. capacitive load (current range)	-	1 μF	1 μF	1 μF
Output voltage ranges	-	-10 V ... +10 V	0 V ... +10 V	-10 V ... +10 V
Operational limit of voltage ranges	-	+/-0.3%	+/-0.2%	+/-0.2%
Basic error limit voltage ranges with SFU	-	+/-0.2%	+/-0.1%	+/-0.1%
Current outputs	✓	-	-	-
Max. in load resistance (current range)	350 Ω	-	-	-
Max. inductive load (current range)	10 mH	-	-	-
Output current ranges	0 mA ... +20 mA +4 mA ... +20 mA	-	-	-
Operational limit of current ranges	+/-0.4% ... +/-0.5%	-	-	-
Basic error limit current ranges with SFU	+/-0.2% ... +/-0.3%	-	-	-
Settling time for ohmic load	0.25 ms	1.5 ms	150 μs	150 μs
Settling time for capacitive load	-	2 ms	1 ms	1 ms
Settling time for inductive load	1.5 ms	-	-	-
Resolution in bit	12	12	16	16
Conversion time	2 ms all channels	2 ms all channels	200 μs all channels	200 μs all channels
Substitute value can be applied	no	no	no	no
<b>Status information, alarms, diagnostics</b>				
Status display	yes	yes	yes	yes
Interrupts	no	no	no	no
Process alarm	no	no	no	no
Diagnostic interrupt	no	no	no	no
Diagnostic functions	yes	yes	yes	yes

Signal modules analog   Analog output modules					
032-1BB30	032-1BD40	032-1CD30			
032-1BB40	032-1BD70	032-1CD70			
032-1BB70	032-1CB30				
032-1BD30	032-1CB70				

Order number	032-1BD40	032-1BD70	032-1CB30	032-1CB70
Diagnostics information read-out	possible	possible	possible	possible
Module state	green LED	green LED	green LED	green LED
Module error display	red LED	red LED	red LED	red LED
Channel error display	red LED per channel	red LED per channel	red LED per channel	red LED per channel
<b>Isolation</b>				
Between channels	-	-	-	-
Between channels of groups to	-	-	-	-
Between channels and backplane bus	✓	✓	✓	✓
Between channels and power supply	✓	✓	✓	✓
Max. potential difference between circuits	-	-	-	-
Max. potential difference between inputs (Ucm)	-	-	-	-
Max. potential difference between Mana and Mintern (Uiso)	DC 75 V/ AC 60 V	DC 75 V/ AC 60 V	DC 75 V/ AC 60 V	DC 75 V/ AC 60 V
Max. potential difference between inputs and Mana (Ucm)	-	-	-	-
Max. potential difference between inputs and Mintern (Uiso)	-	-	-	-
Max. potential difference between Mintern and outputs	-	-	-	-
Insulation tested with	DC 500 V	DC 500 V	DC 500 V	DC 500 V
<b>Datasizes</b>				
Input bytes	0	0	0	0
Output bytes	8	8	4	4
Parameter bytes	10	10	8	8
Diagnostic bytes	20	20	20	20
<b>Housing</b>				
Material	PPE / PPE GF10	PPE / PPE GF10	PPE / PPE GF10	PPE / PPE GF10
Mounting	Profile rail 35 mm	Profile rail 35 mm	Profile rail 35 mm	Profile rail 35 mm
<b>Mechanical data</b>				
Dimensions (WxHxD)	12.9 mm x 109 mm x 76.5 mm	12.9 mm x 109 mm x 76.5 mm	12.9 mm x 109 mm x 76.5 mm	12.9 mm x 109 mm x 76.5 mm
Weight	60 g	60 g	60 g	60 g
<b>Environmental conditions</b>				
Operating temperature	0 °C to 60 °C	0 °C to 60 °C	0 °C to 60 °C	0 °C to 60 °C
Storage temperature	-25 °C to 70 °C	-25 °C to 70 °C	-25 °C to 70 °C	-25 °C to 70 °C
<b>Certifications</b>				
UL508 certification	yes	in preparation	in preparation	in preparation

# Connections, Interfaces

Signal modules analog | Analog output modules

032-1BB30	032-1BD40	032-1CD30			
032-1BB40	032-1BD70	032-1CD70			
032-1BB70	032-1CB30				
032-1BD30	032-1CB70				

## 032-1BD40

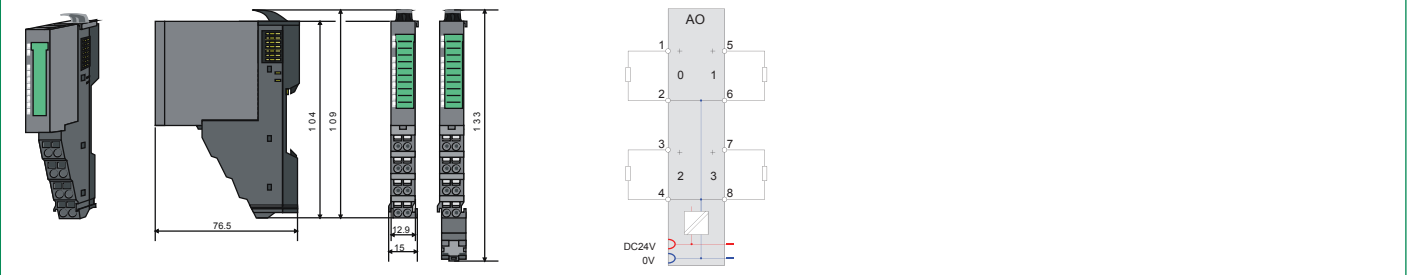

## 032-1BD70

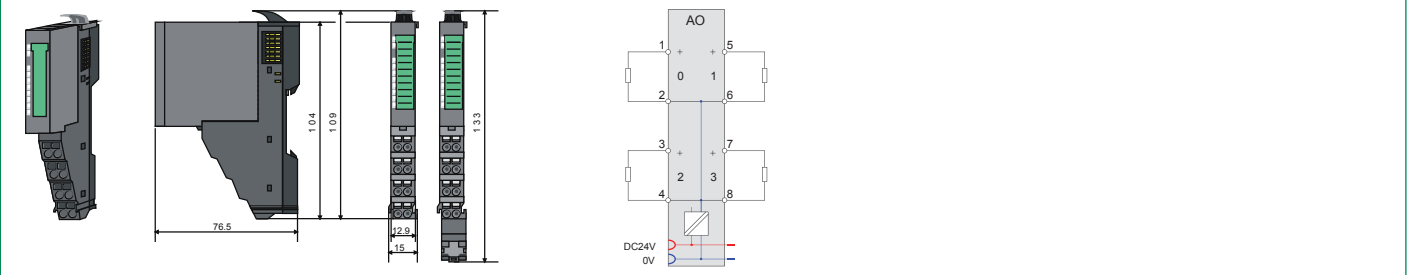

## 032-1CB30

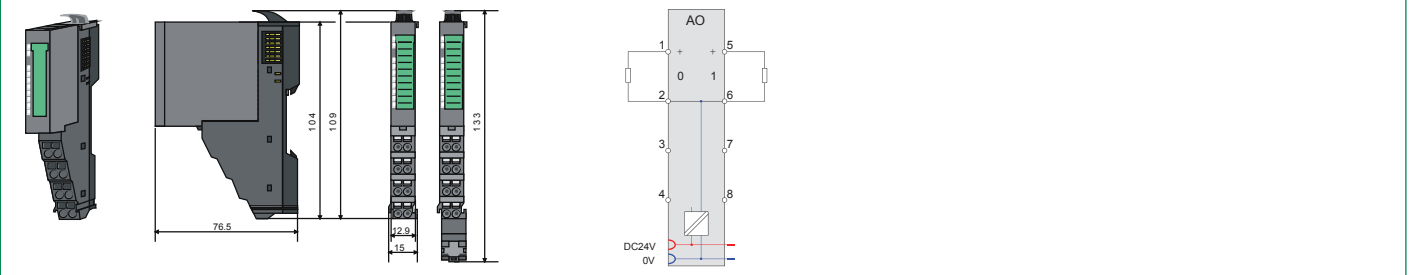

## 032-1CB70

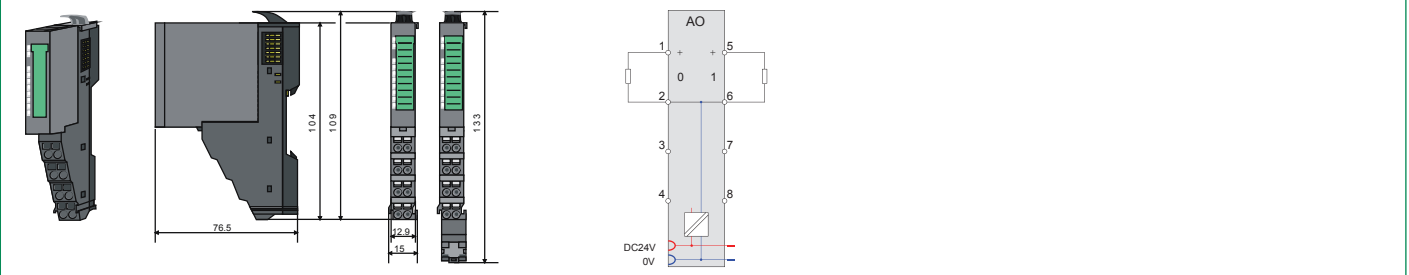

# Analog output modules

## Signal modules analog | Analog output modules

032-1BB30	032-1BD40	032-1CD30			
032-1BB40	032-1BD70	032-1CD70			
032-1BB70	032-1CB30				
032-1BD30	032-1CB70				

Order number	032-1CD30	032-1CD70		
Figure				
Type	SM 032	SM 032		
Module ID	0509 2560	050A 2560		
<b>General information</b>				
Note	-	-		
Features	<ul style="list-style-type: none"> <li>▸ 4 outputs 16Bit</li> <li>▸ Voltage 0...10 V</li> </ul>	<ul style="list-style-type: none"> <li>▸ 4 outputs 16Bit</li> <li>▸ Voltage -10 V...+10 V</li> </ul>		
<b>Current consumption/power loss</b>				
Current consumption from backplane bus	60 mA	60 mA		
Power loss	0.8 W	0.8 W		
<b>Technical data analog outputs</b>				
Number of outputs	4	4		
Cable length, shielded	200 m	200 m		
Rated load voltage	DC 24 V	DC 24 V		
Current consumption from load voltage L+ (without load)	-	-		
Voltage output short-circuit protection	✓	✓		
Voltage outputs	✓	✓		
Min. load resistance (voltage range)	5 kΩ	5 kΩ		
Max. capacitive load (current range)	1 μF	1 μF		
Output voltage ranges	0 V ... +10 V	-10 V ... +10 V		
Operational limit of voltage ranges	+/-0.2%	+/-0.2%		
Basic error limit voltage ranges with SFU	+/-0.1%	+/-0.1%		
Current outputs	-	-		
Max. in load resistance (current range)	-	-		
Max. inductive load (current range)	-	-		
Output current ranges	-	-		
Operational limit of current ranges	-	-		
Basic error limit current ranges with SFU	-	-		
Settling time for ohmic load	150 μs	150 μs		
Settling time for capacitive load	1 ms	2 ms		
Settling time for inductive load	-	-		
Resolution in bit	16	16		
Conversion time	200 μs all channels	200 μs all channels		
Substitute value can be applied	no	no		
<b>Status information, alarms, diagnostics</b>				
Status display	yes	yes		
Interrupts	no	no		
Process alarm	no	no		
Diagnostic interrupt	no	no		
Diagnostic functions	yes	yes		
Diagnostics information read-out	possible	possible		

## Signal modules analog | Analog output modules

032-1BB30	032-1BD40	032-1CD30				
032-1BB40	032-1BD70	032-1CD70				
032-1BB70	032-1CB30					
032-1BD30	032-1CB70					

Order number	032-1CD30	032-1CD70		
Module state	green LED	green LED		
Module error display	red LED	red LED		
Channel error display	red LED per channel	red LED per channel		
<b>Isolation</b>				
Between channels	-	-		
Between channels of groups to	-	-		
Between channels and backplane bus	✓	✓		
Between channels and power supply	✓	✓		
Max. potential difference between circuits	-	-		
Max. potential difference between inputs (Ucm)	-	-		
Max. potential difference between Mana and Mintern (Uiso)	DC 75 V/ AC 60 V	DC 75 V/ AC 60 V		
Max. potential difference between inputs and Mana (Ucm)	-	-		
Max. potential difference between inputs and Mintern (Uiso)	-	-		
Max. potential difference between Mintern and outputs	-	-		
Insulation tested with	DC 500 V	DC 500 V		
<b>Datasizes</b>				
Input bytes	0	0		
Output bytes	8	8		
Parameter bytes	10	10		
Diagnostic bytes	20	20		
<b>Housing</b>				
Material	PPE / PPE GF10	PPE / PPE GF10		
Mounting	Profile rail 35 mm	Profile rail 35 mm		
<b>Mechanical data</b>				
Dimensions (WxHxD)	12.9 mm x 109 mm x 76.5 mm	12.9 mm x 109 mm x 76.5 mm		
Weight	60 g	60 g		
<b>Environmental conditions</b>				
Operating temperature	0 °C to 60 °C	0 °C to 60 °C		
Storage temperature	-25 °C to 70 °C	-25 °C to 70 °C		
<b>Certifications</b>				
UL508 certification	in preparation	in preparation		

# Connections, Interfaces

Signal modules analog | Analog output modules

032-1BB30	032-1BD40	032-1CD30			
032-1BB40	032-1BD70	032-1CD70			
032-1BB70	032-1CB30				
032-1BD30	032-1CB70				

032-1CD30

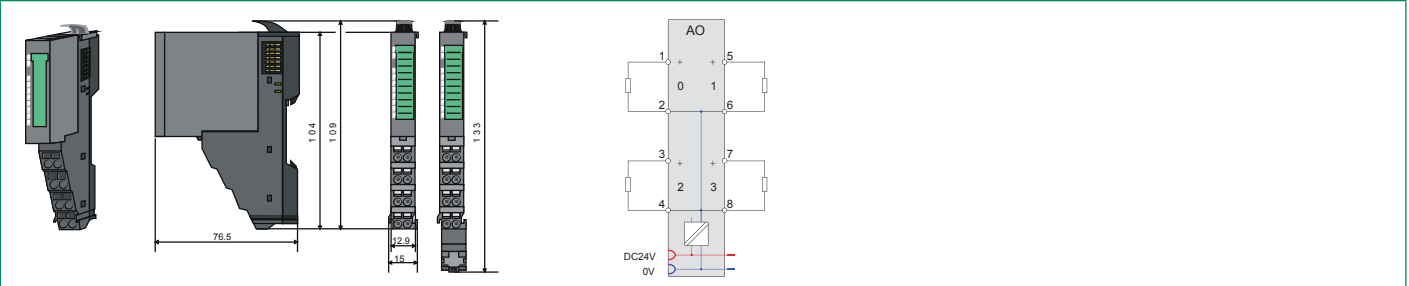

032-1CD70

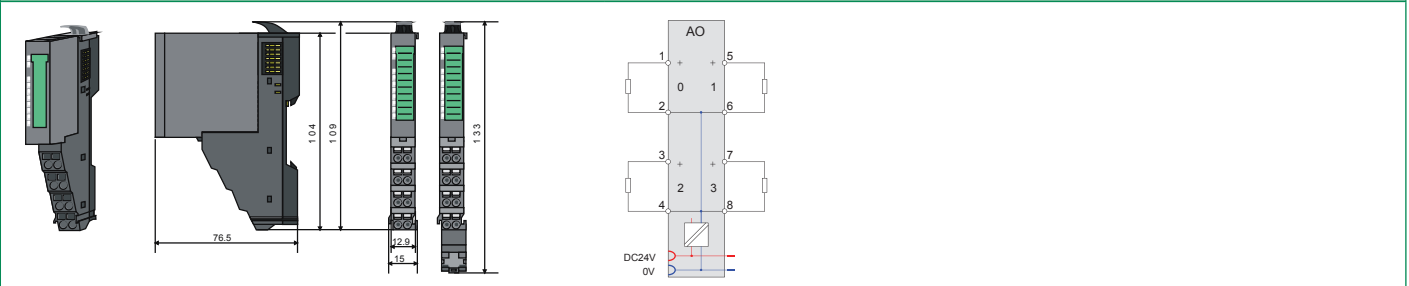

# Communication processors



## Structure and Function

Communications processors are used to connect different target and source systems, e.g. via Ethernet to higher-level ERP systems or serially to scanners, printers and other peripherals.

### CP 040

The communication processors CP 040 enable the serial process coupling to different target and source systems. Depending on the module they have a RS232 or a RS422/485 interface.

### Characteristics

- › Support for all standard protocols ASCII, STX/ETX, 3964(R) and Modbus (master, slave)
- › Internal communication via VIPA FBs
- › Compact design
- › LED status indicator
- › Electrically isolated to the backplane bus
- › Assembly with 35 mm profile rail
- › 24 month warranty

# Overview

Order no.	Name/Description	Page
RS232/422/485 and other CPs		
040-1BA00	<b>CP 040 - Communication processor</b> › RS232 interface	<b>84</b>
040-1CA00	<b>CP 040 - Communication processor</b> › RS422/485 interface	<b>84</b>

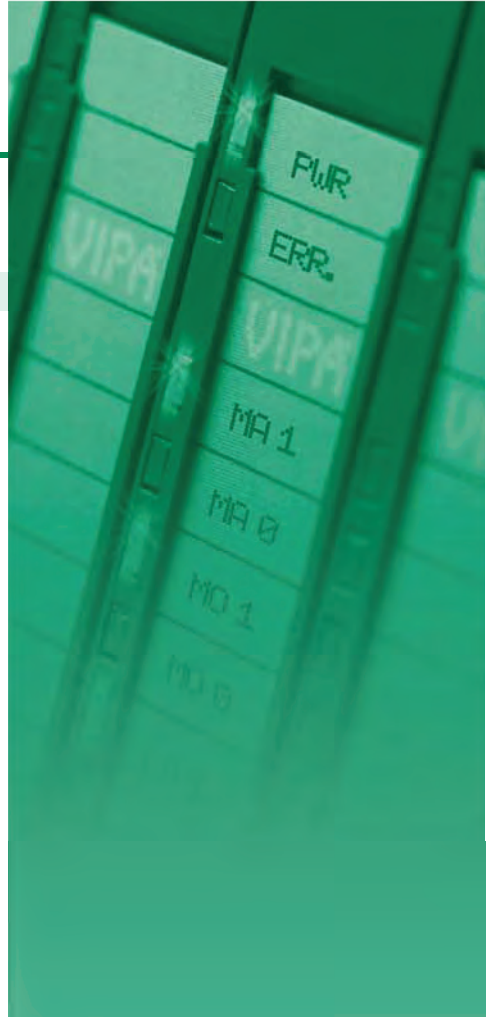

# RS232/422/485 and other CPs

Communication processors   RS232/422/485 and other CPs					
040-1BA00					
040-1CA00					

Order number	040-1BA00	040-1CA00		
Figure				
Type	CP 040 RS232	CP 040 RS422/485		
Module ID	0E01 0700	0E41 1700		
<b>General information</b>				
Note	-	-		
Features	› RS232 interface	› RS422/485 interface		
<b>Current consumption/power loss</b>				
Current consumption from backplane bus	100 mA	100 mA		
Current consumption from load voltage L+ (without load)	10 mA	10 mA		
Power loss	1 W	1 W		
<b>Status information, alarms, diagnostics</b>				
Status display	yes	yes		
Interrupts	yes, parameterizable	yes, parameterizable		
Process alarm	no	no		
Diagnostic interrupt	yes, parameterizable	yes, parameterizable		
Diagnostic functions	yes, parameterizable	yes, parameterizable		
Diagnostics information read-out	possible	possible		
Supply voltage display	green LED	green LED		
Group error display	red LED	red LED		
Channel error display	red LED	red LED		
<b>Point-to-point communication</b>				
PtP communication	✓	✓		
Interface isolated	✓	✓		
RS232 interface	✓	-		
RS422 interface	-	✓		
RS485 interface	-	✓		
Connector	Terminal module	Terminal module		
Transmission speed, min.	150 bit/s	150 bit/s		
Transmission speed, max.	115.2 kbit/s	115.2 kbit/s		
Cable length, max.	15 m	1200 m		
<b>Point-to-point protocol</b>				
ASCII protocol	✓	✓		
STX/ETX protocol	✓	✓		
3964(R) protocol	✓	✓		
RK512 protocol	-	-		
USS master protocol	-	-		
Modbus master protocol	✓	✓		
Modbus slave protocol	✓	✓		
Special protocols	-	-		

SLO  
100V  
200V  
300S  
500S  
HMI  
Software  
Accessories  
Appendix

Communication processors | RS232/422/485 and other CPs

040-1BA00 040-1CA00						
------------------------	--	--	--	--	--	--

Order number	040-1BA00	040-1CA00		
<b>Datasizes</b>				
Input bytes	8 / 20 / 60	8 / 20 / 60		
Output bytes	8 / 20 / 60	8 / 20 / 60		
Parameter bytes	21	23		
Diagnostic bytes	20	20		
<b>Housing</b>				
Material	PPE / PPE GF10	PPE / PPE GF10		
Mounting	Profile rail 35 mm	Profile rail 35 mm		
<b>Mechanical data</b>				
Dimensions (WxHxD)	12.9 mm x 109 mm x 76.5 mm	12.9 mm x 109 mm x 76.5 mm		
Weight	60 g	60 g		
<b>Environmental conditions</b>				
Operating temperature	0 °C to 60 °C	0 °C to 60 °C		
Storage temperature	-25 °C to 70 °C	-25 °C to 70 °C		
<b>Certifications</b>				
UL508 certification	yes	yes		

# Connections, Interfaces

Communication processors   RS232/422/485 and other CPs					
040-1BA00					
040-1CA00					

### 040-1BA00

**CP 040**

1 Tx/D  
2 Rx/D  
3 CTS  
4 RTS  
5 GND  
6 DCD  
7 DTR  
8 DSR

DC 24 V  
0 V

**CP 040**

1 Tx/D  
2 Rx/D  
3 GND  
4 RTS  
5 CTS  
6 DTR  
7 DCD  
8 shield

**Periphery**

1 Tx/D  
2 Rx/D  
3 GND  
4 RTS  
5 CTS  
6 DTR  
7 DCD  
8 shield

### 040-1CA00

**CP 040**

1 Tx/D+  
2 Tx/D-  
3 Rx/D+  
4 Rx/D-  
5 RTS  
6 GND\_ISO  
7 TERM  
8 TERM

DC 24 V  
0 V

**CP 040**

1 Tx/D-N (A)  
2 Tx/D-P (B)  
3 Rx/D-N (A)  
4 Rx/D-P (B)  
5 GND\_ISO  
6 shield  
7 Tx/D-N (A)  
8 Tx/D-P (B)

**Periphery**

1 Rx/D-Tx (B)  
2 Rx/D-Tx (A)  
3 (GND)  
4 Rx/D-Tx (B)  
5 Rx/D-Tx (A)  
6 (GND)  
7 Rx/D-Tx (B)  
8 Rx/D-Tx (A)

**Periphery**

1 Send  
2 Receive  
3 Tx/D-N (A)  
4 Tx/D-P (B)  
5 Tx/D-N (A)  
6 Tx/D-P (B)  
7 (GND)  
8 shield



# Function modules



## Structure and Function

Function modules (FM) are intelligent modules that perform technological tasks such as position determination, counting and positioning, and other complex functions in the automation independently. They are used when there are high demands on accuracy and dynamic in the starting of automation tasks.

Different functional modules, for example counter modules, SSI modules provide exactly the functions that are required for the respective tasks.

Each functional module consists of a terminal and an electronic module.

The terminal module (TM) contains the retainer for the electronic module (EM), the backplane connectors and contacts for the distribution of the load power supply electronics, the modular connection to DC 24 V load power supply and the staircase-shaped terminal block for the wiring.

Furthermore the terminal module processes a locking system for fixing to a profile rail. The SLIO system can also be constructed "block by block" outside the cabinet and later assembled as a complete system in the control cabinet.

The functionality of the signal module is defined via the electronic module that is connected by a secure sliding mechanism to the terminal module.

During service the defective electronic module can be replaced without detaching the wiring.

### Characteristics

- › Supports fast counter systems up to 1 MHz
- › Counting direction invertible
- › Integrated digital outputs
- › For direct connection of incremental encoders
- › Electrically isolated to the backplane bus
- › Direct mapping and readability of the channel conditions via status LEDs
- › Safe and time-saving installation by the terminal assignment mounted on the module
- › When changing the module equipment identification (BMK) is retained on the TM
- › Individual single-channel lettering on insertion strip
- › 24 month warranty

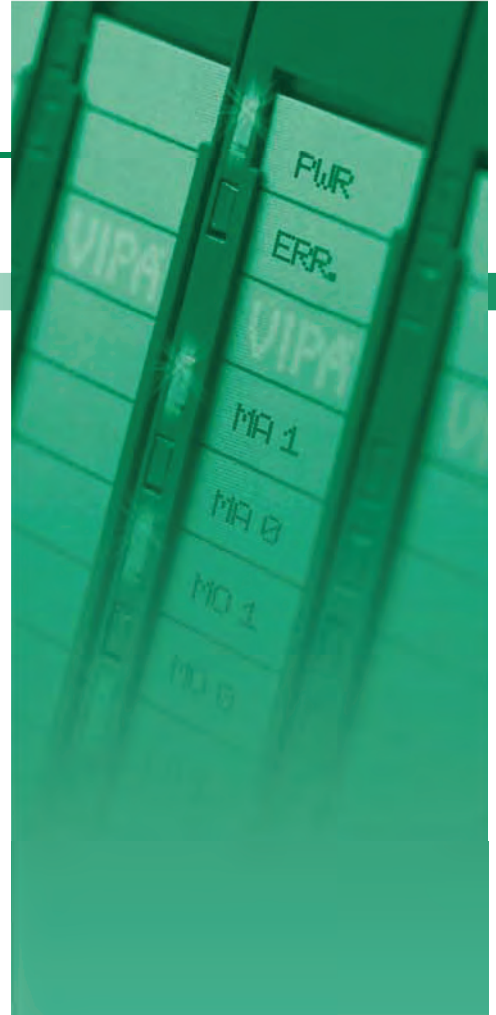



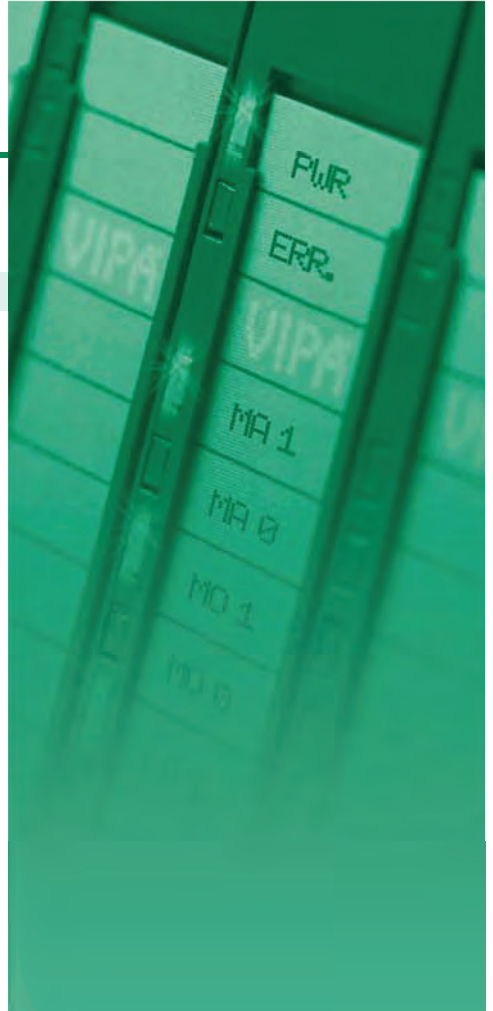

# Overview

Order no.	Name/Description	Page
Counter modules		
050-1BA00	<b>FM 050 - Counter module</b> ▶ 1 Counter 32 Bit (AB) ▶ DC 24 V	90
050-1BA10	<b>FM 050 - Counter module</b> ▶ 1 Counter 32 Bit (AB) ▶ DC 5 V	90
050-1BB00	<b>FM 050 - Counter module</b> ▶ 2 Counter 32 Bit (AB) ▶ DC 24 V	90
050-1BB30	<b>FM 050 - Counter module</b> ▶ 2 Counter 32 Bit (AB) ▶ DC 24 V	90
SSI modules		
050-1BS00	<b>FM 050S - SSI module</b> ▶ SSI - Encoder ▶ Master or slave mode ▶ Encoder frequency 125 kHz...2 MHz ▶ µs time stamp for encoder value	94



# Counter modules

Function modules   Counter modules						
050-1BA00						
050-1BA10						
050-1BB00						
050-1BB30						

Order number	050-1BA00	050-1BA10	050-1BB00	050-1BB30
Figure				
Type	FM 050	FM 050	FM 050	FM 050
Module ID	08C1 3800	08C2 3801	08C3 380A	08C4 388B
<b>General information</b>				
Note	-	-	-	-
Features	<ul style="list-style-type: none"> <li>▸ 1 Counter 32 Bit (AB)</li> <li>▸ DC 24 V</li> </ul>	<ul style="list-style-type: none"> <li>▸ 1 Counter 32 Bit (AB)</li> <li>▸ DC 5 V</li> </ul>	<ul style="list-style-type: none"> <li>▸ 2 Counter 32 Bit (AB)</li> <li>▸ DC 24 V</li> </ul>	<ul style="list-style-type: none"> <li>▸ 2 Counter 32 Bit (AB)</li> <li>▸ DC 24 V</li> </ul>
<b>Current consumption/power loss</b>				
Current consumption from backplane bus	75 mA	70 mA	75 mA	75 mA
Power loss	1 W	0.85 W	0.9 W	0.9 W
<b>Technical data digital inputs</b>				
Number of inputs	5	-	4	4
Cable length, shielded	100 m	100 m	100 m	100 m
Cable length, unshielded	-	-	-	-
Rated load voltage	DC 20.4...28.8 V	DC 20.4...28.8 V	DC 20.4...28.8 V	DC 20.4...28.8 V
Reverse polarity protection of rated load voltage	-	-	-	-
Current consumption from load voltage L+ (without load)	20 mA	20 mA	15 mA	15 mA
Rated value	DC 20.4...28.8 V	-	DC 20.4...28.8 V	DC 20.4...28.8 V
Input voltage for signal "0"	DC 0...5 V	Differential signal RS422	DC 0...5 V	DC 0...5 V
Input voltage for signal "1"	DC 15...28.8 V	Differential signal RS422	DC 15...28.8 V	DC 15...28.8 V
Input voltage hysteresis	-	-	-	-
Frequency range	-	-	-	-
Input resistance	-	120 Ω	-	-
Input current for signal "1"	3 mA	-	3 mA	3 mA
Connection of Two-Wire-BEROs possible	✓	-	✓	✓
Max. permissible BERO quiescent current	0.5 mA	-	0.5 mA	0.5 mA
Input delay of "0" to "1"	0,8 μs	0,8 μs	0,8 μs	0,8 μs
Input delay of "1" to "0"	0,8 μs	0,8 μs	0,8 μs	0,8 μs
Number of simultaneously utilizable inputs horizontal configuration	5	-	4	4
Number of simultaneously utilizable inputs vertical configuration	5	-	4	4
Input characteristic curve	IEC 61131, type 1	-	IEC 61131, type 1	IEC 61131, type 1
Initial data size	12 Byte	8 Byte	12 Byte	12 Byte
<b>Technical data digital outputs</b>				
Number of outputs	1	-	-	-
Cable length, shielded	100 m	-	-	-
Cable length, unshielded	100 m	-	-	-
Rated load voltage	DC 20.4...28.8 V	-	-	-

SLO

100V

200V

300S

500S

HMI

Software

Accessories

Appendix

Function modules   Counter modules						
050-1BA00						
050-1BA10						
050-1BB00						
050-1BB30						

Order number	050-1BA00	050-1BA10	050-1BB00	050-1BB30
Current consumption from load voltage L+ (without load)	-	-	-	-
Output delay of "0" to "1"	30 µs	-	-	-
Output delay of "1" to "0"	30 µs	-	-	-
Minimum load current	-	-	-	-
Lamp load	10 W	-	-	-
Parallel switching of outputs for redundant control of a load	not possible	-	-	-
Parallel switching of outputs for increased power	not possible	-	-	-
Actuation of digital input	✓	-	-	-
Switching frequency with resistive load	max. 10 kHz	-	-	-
Switching frequency with inductive load	max. 0.5 Hz	-	-	-
Switching frequency on lamp load	max. 10 kHz	-	-	-
Internal limitation of inductive shut-off voltage	L+ (-52 V)	-	-	-
Short-circuit protection of output	yes, electronic	-	-	-
Trigger level	1 A	-	-	-
Number of operating cycle of relay outputs	-	-	-	-
Switching capacity of contacts	-	-	-	-
Output data size	10 Byte	10 Byte	12 Byte	4 Byte
<b>Technical data counters</b>				
Number of counters	1	1	2	2
Counter width	32 Bit	32 Bit	32 Bit	32 Bit
Maximum input frequency	100 kHz	500 kHz	100 kHz	100 kHz
Maximum count frequency	400 kHz	2 MHz	400 kHz	400 kHz
Mode incremental encoder	✓	✓	✓	✓
Mode pulse / direction	✓	✓	✓	✓
Mode pulse	-	-	-	-
Mode frequency counter	-	-	-	-
Mode period measurement	-	-	-	-
Gate input available	✓	-	-	-
Latch input available	✓	-	-	-
Reset input available	✓	✓	-	-
Counter output available	✓	-	-	-
<b>Status information, alarms, diagnostics</b>				
Status display	yes	yes	yes	yes
Interrupts	yes, parameterizable	yes, parameterizable	yes, parameterizable	no
Process alarm	yes, parameterizable	yes, parameterizable	yes, parameterizable	no
Diagnostic interrupt	yes, parameterizable	yes, parameterizable	yes, parameterizable	no
Diagnostic functions	yes, parameterizable	yes, parameterizable	yes, parameterizable	no
Diagnostics information read-out	possible	possible	possible	possible
Module state	green LED	green LED	green LED	green LED
Module error display	red LED	red LED	red LED	red LED
Channel error display	none	none	none	none

Function modules   Counter modules						
050-1BA00						
050-1BA10						
050-1BB00						
050-1BB30						

Order number	050-1BA00	050-1BA10	050-1BB00	050-1BB30
<b>Isolation</b>				
Between channels	-	-	-	-
Between channels of groups to	-	-	-	-
Between channels and backplane bus	✓	✓	✓	✓
Between channels and power supply	-	-	-	-
Max. potential difference between circuits	-	-	-	-
Max. potential difference between inputs (Ucm)	-	-	-	-
Max. potential difference between Mana and Mintern (Uiso)	-	-	-	-
Max. potential difference between inputs and Mana (Ucm)	-	-	-	-
Max. potential difference between inputs and Mintern (Uiso)	-	-	-	-
Max. potential difference between Mintern and outputs	-	-	-	-
Insulation tested with	DC 500 V	DC 500 V	DC 500 V	DC 500 V
<b>Datasizes</b>				
Input bytes	12	8	12	12
Output bytes	10	10	12	4
Parameter bytes	25	23	45	12
Diagnostic bytes	20	20	20	20
<b>Housing</b>				
Material	PPE / PPE GF10	PPE / PPE GF10	PPE / PPE GF10	PPE / PPE GF10
Mounting	Profile rail 35 mm	Profile rail 35 mm	Profile rail 35 mm	Profile rail 35 mm
<b>Mechanical data</b>				
Dimensions (WxHxD)	12.9 mm x 109 mm x 76.5 mm	12.9 mm x 109 mm x 76.5 mm	12.9 mm x 109 mm x 76.5 mm	12.9 mm x 109 mm x 76.5 mm
Weight	60 g	60 g	60 g	60 g
<b>Environmental conditions</b>				
Operating temperature	0 °C to 60 °C	0 °C to 60 °C	0 °C to 60 °C	0 °C to 60 °C
Storage temperature	-25 °C to 70 °C	-25 °C to 70 °C	-25 °C to 70 °C	-25 °C to 70 °C
<b>Certifications</b>				
UL508 certification	yes	yes	yes	yes

SLO  
100V  
200V  
300S  
500S  
HMI  
Software  
Accessories  
Appendix

# Connections, Interfaces

Function modules | Counter modules

- 050-1BA00
- 050-1BA10
- 050-1BB00
- 050-1BB30

## 050-1BA00

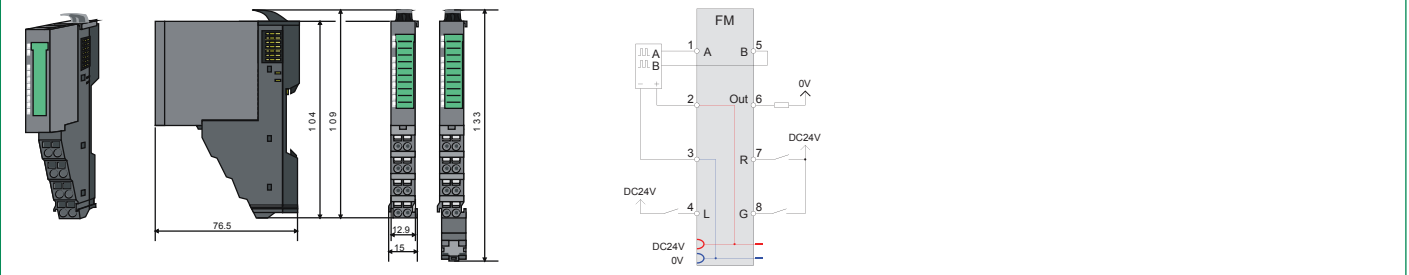

## 050-1BA10

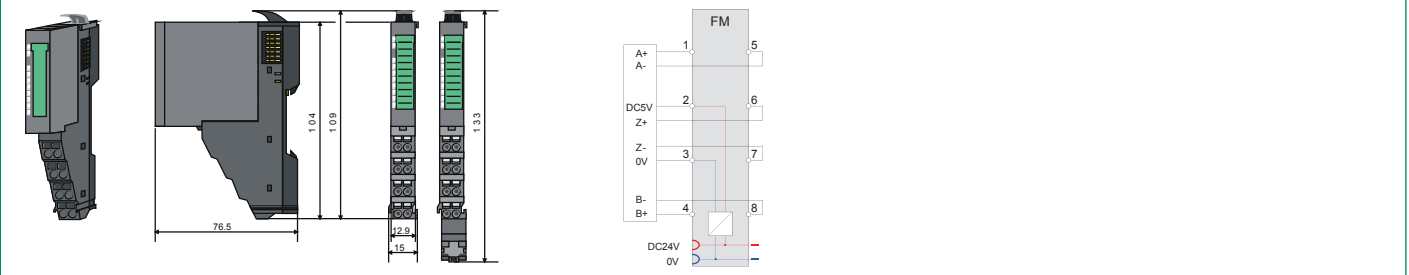

## 050-1BB00

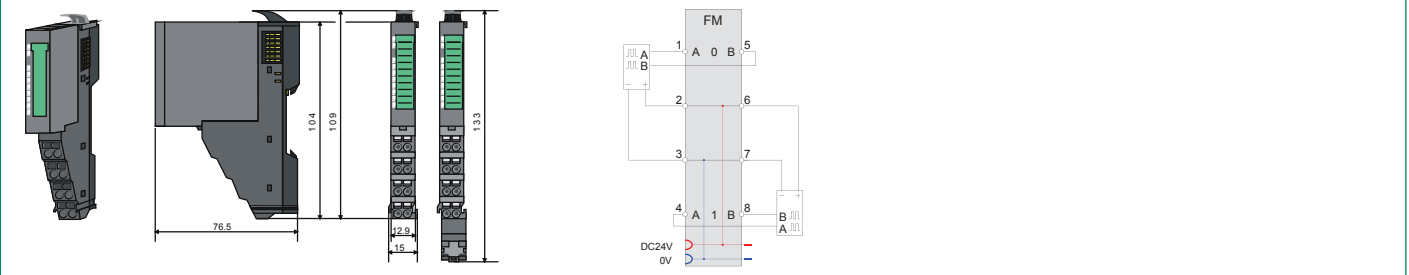

## 050-1BB30

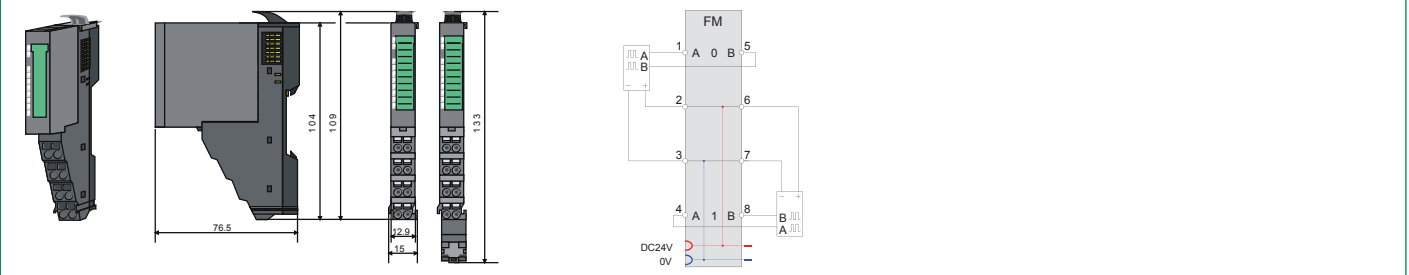

# SSI modules

Function modules   SSI modules						
050-1BS00						

Order number	050-1BS00			
Figure				
Type	FM 050			
Module ID	09C1 7800			
General information				
Note	-			
Features	<ul style="list-style-type: none"> <li>▸ SSI - Encoder</li> <li>▸ Master or slave mode</li> <li>▸ Encoder frequency 125 kHz...2 MHz</li> <li>▸ µs time stamp for encoder value</li> </ul>			
Current consumption/power loss				
Current consumption from backplane bus	70 mA			
Power loss	1 W			
Parallel switching of outputs for increased power	-			
Status information, alarms, diagnostics				
Status display	yes			
Interrupts	yes, parameterizable			
Process alarm	no			
Diagnostic interrupt	yes, parameterizable			
Diagnostic functions	yes, parameterizable			
Diagnostics information read-out	possible			
Module state	green LED			
Module error display	red LED			
Channel error display	none			
Isolation				
Between channels	-			
Between channels of groups to	-			
Between channels and backplane bus	✓			
Between channels and power supply	-			
Max. potential difference between circuits	-			
Max. potential difference between inputs (Ucm)	-			
Max. potential difference between Mana and Mintern (Uiso)	-			
Max. potential difference between inputs and Mana (Ucm)	-			
Max. potential difference between inputs and Mintern (Uiso)	-			
Max. potential difference between Mintern and outputs	-			
Insulation tested with	DC 500 V			

Function modules   SSI modules						
050-1BS00						

<b>Order number</b>	<b>050-1BS00</b>			
<b>Datasizes</b>				
Input bytes	6			
Output bytes	0			
Parameter bytes	17			
Diagnostic bytes	20			
<b>Housing</b>				
Material	PPE / PPE GF10			
Mounting	Profile rail 35 mm			
<b>Mechanical data</b>				
Dimensions (WxHxD)	12.9 mm x 109 mm x 76.5 mm			
Weight	60 g			
<b>Environmental conditions</b>				
Operating temperature	0 °C to 60 °C			
Storage temperature	-25 °C to 70 °C			
<b>Certifications</b>				
UL508 certification	yes			

# Connections, Interfaces

Function modules   SSI modules						
050-1BS00						

**050-1BS00**

The technical drawing includes the following dimensions and terminal block details:

- Dimensions:**
  - Front view width: 76.5
  - Top view depth: 104
  - Top view depth: 109
  - Side view height: 12.9
  - Side view height: 15
  - Rear view height: 133
- Terminal Block Diagram (FM):**
  - 1: CO+
  - 2: CO-
  - 3: DI+
  - 4: DI-
  - 5: (unlabeled)
  - 6: (unlabeled)
  - 7: (unlabeled)
  - 8: (unlabeled)
  - DC24V (red wire)
  - 0V (blue wire)



# Interface modules



## Structure and Function

Interface modules (IM) form the interface between process level and parent bus system. All control signals are transmitted through the internal backplane bus to the electronics module (EM).

In the case of the interface module the bus interface and power module (PM) are integrated in a single casing. Both the bus interface and the electronics of the connected peripheral modules are supplied with power via the integrated power module.

Up to 64 I/O modules can be operated on the interface module.

### Characteristics

- › Support for various fieldbus systems
- › Functional DIP switches for address setting for the PROFIBUS-DP and CANopen with transparent cover
- › MAC address on the front in plain text
- › Electrical isolation between fieldbus and input/output field
- › Integrated DC 24 V power module to the electronic and load voltage supply of the peripheral modules
- › Easy to maintain, replaceable power module
- › Up to 64 signal and function modules per interface module
- › 24 month warranty

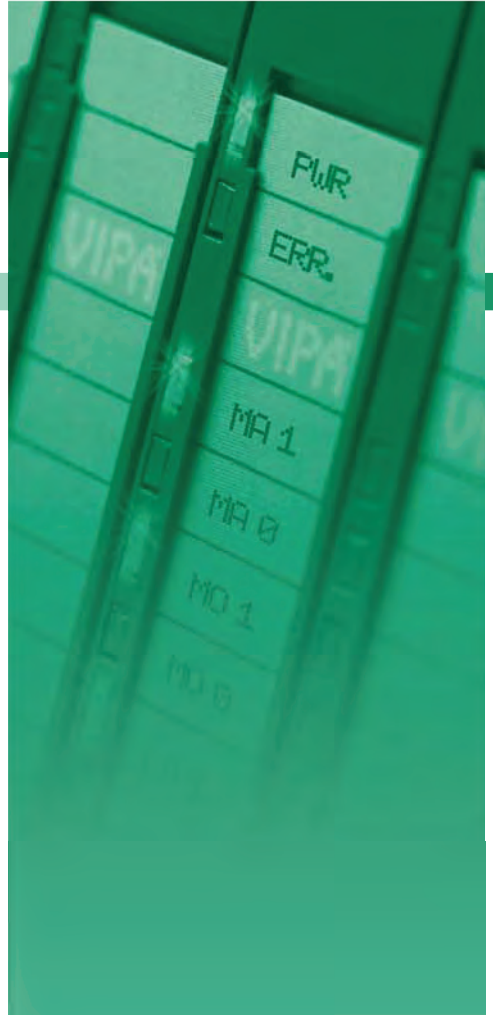



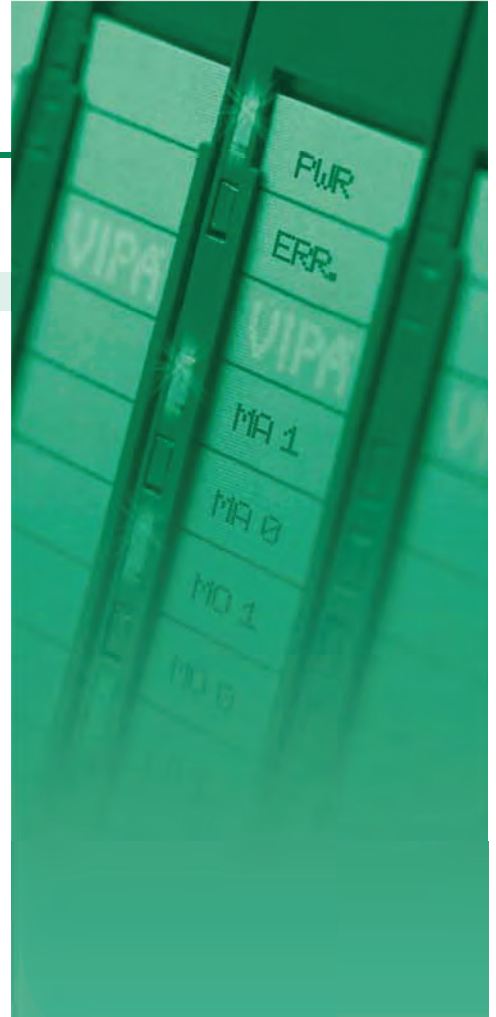

# Overview

Order no.	Name/Description	Page
Fieldbus slave modules without I/Os		
053-1CA00	<b>IM 053CAN - CANopen slave</b> ▶ CANopen slave ▶ 16 Rx and 16 Tx PDOs ▶ 2 SDOs ▶ PDO linking ▶ PDO mapping: fix ▶ max. 64 peripheral modules	100
053-1DN00	<b>IM 053DN - DeviceNet slave</b> ▶ DeviceNet slave ▶ Group 2 only device ▶ Poll only device ▶ Baud rate: 125, 250 and 500kbit/s ▶ max. 64 peripheral modules	100
053-1DP00	<b>IM 053DP - PROFIBUS-DP slave</b> ▶ PROFIBUS-DP slave (DP-V0, DP-V1) ▶ 244 Byte input and 244 Byte output data ▶ 64 peripheral modules max.	100
053-1EC00	<b>IM 053EC - EtherCAT slave</b> ▶ EtherCAT slave ▶ RJ45 jack 100BaseTX ▶ 64 peripheral modules max.	100
053-1MT00	<b>IM 053MT - Modbus/TCP slave</b> ▶ Modbus/TCP slave ▶ I/O configuration via fieldbus ▶ Adjustable I/O cycle (0.5...4 ms) ▶ max. 64 peripheral modules	103
053-1PN00	<b>IM 053PN - PROFINET-IO slave</b> ▶ PROFINET-IO slave ▶ Transfer rate 100Mbit/s ▶ max. 64 peripheral modules	103



# Fieldbus slave modules without I/Os

Interface modules   Fieldbus slave modules without I/Os					
053-1CA00	053-1MT00				
053-1DN00	053-1PN00				
053-1DP00					
053-1EC00					

Order number	053-1CA00	053-1DN00	053-1DP00	053-1EC00
Figure				
Type	IM 053CAN	IM 053DN	IM 053DP	IM 053EC
Module ID	-	-	-	-
<b>General information</b>				
Note	-	-	-	-
Features	<ul style="list-style-type: none"> <li>› CANopen slave</li> <li>› 16 Rx and 16 Tx PDOs</li> <li>› 2 SDOs</li> <li>› PDO linking</li> <li>› PDO mapping: fix</li> <li>› max. 64 peripheral modules</li> </ul>	<ul style="list-style-type: none"> <li>› DeviceNet slave</li> <li>› Group 2 only device</li> <li>› Poll only device</li> <li>› Baud rate: 125, 250 and 500kbit/s</li> <li>› max. 64 peripheral modules</li> </ul>	<ul style="list-style-type: none"> <li>› PROFIBUS-DP slave (DP-V0, DP-V1)</li> <li>› 244 Byte input and 244 Byte output data</li> <li>› 64 peripheral modules max.</li> </ul>	<ul style="list-style-type: none"> <li>› EtherCAT slave</li> <li>› RJ45 jack 100BaseTX</li> <li>› 64 peripheral modules max.</li> </ul>
<b>Technical data power supply</b>				
Power supply (rated value)	DC 24 V	DC 24 V	DC 24 V	DC 24 V
Power supply (permitted range)	DC 20.4...28.8 V	DC 20.4...28.8 V	DC 20.4...28.8 V	DC 20.4...28.8 V
Reverse polarity protection	✓	✓	✓	✓
Current consumption (no-load operation)	90 mA	90 mA	90 mA	95 mA
Current consumption (rated value)	0.95 A	0.95 A	0.95 A	0.95 A
Inrush current	3.9 A	3.9 A	3.9 A	3.9 A
I <sub>∫t</sub>	0.14 A²s	0.14 A²s	0.14 A²s	0.14 A²s
Max. current drain at backplane bus	3 A	3 A	3 A	3 A
Max. current drain load supply	10 A	10 A	10 A	10 A
Power loss	3 W	3 W	3 W	3 W
<b>Status information, alarms, diagnostics</b>				
Status display	yes	yes	yes	yes
Interrupts	yes, parameterizable	-	yes, parameterizable	yes, parameterizable
Process alarm	no	-	yes, parameterizable	yes, parameterizable
Diagnostic interrupt	yes, parameterizable	-	yes, parameterizable	yes, parameterizable
Diagnostic functions	yes, parameterizable	-	yes, parameterizable	yes, parameterizable
Diagnostics information read-out	possible	possible	possible	possible
Supply voltage display	green LED	green LED	green LED	green LED
Service Indicator	-	-	-	-
Group error display	red LED	red SF LED	red LED	red SF LED
Channel error display	none	none	none	none
<b>Hardware configuration</b>				
Racks, max.	1	1	1	1
Modules per rack, max.	64	64	64	64
Number of digital modules, max.	64	64	64	64
Number of analog modules, max.	64	64	64	64

SLO  
 100V  
 200V  
 300S  
 500S  
 HMI  
 Software  
 Accessories  
 Appendix

Interface modules   Fieldbus slave modules without I/Os						
053-1CA00	053-1MT00					
053-1DN00	053-1PN00					
053-1DP00						
053-1EC00						

Order number	053-1CA00	053-1DN00	053-1DP00	053-1EC00
<b>Communication</b>				
Fieldbus	CANopen	DeviceNet	PROFIBUS-DP to EN 50170	EtherCAT
Type of interface	CAN	CAN	RS485 isolated	Ethernet 100 MBit
Connector	Sub-D, 9-pin, male	5-pin Open Style Connector	Sub-D, 9-pin, female	2 x RJ45
Topology	Linear bus with bus termination at both ends	Linear bus with bus termination at both ends	Linear bus with bus termination at both ends	-
Electrically isolated	✓	✓	✓	✓
Number of participants, max.	127	64	125	65535
Node addresses	1 - 127	0 - 63	1 - 125	-
Transmission speed, min.	10 kbit/s	125 kbit/s	9.6 kbit/s	100 Mbit/s
Transmission speed, max.	1 Mbit/s	500 kbit/s	12 Mbit/s	100 Mbit/s
Address range inputs, max.	128 Byte	256 Byte	244 Byte	4 KB
Address range outputs, max.	128 Byte	256 Byte	244 Byte	4 KB
Number of TxPDOs, max.	16	-	-	-
Number of RxPDOs, max.	16	-	-	-
<b>Housing</b>				
Material	PPE / PPE GF10	PPE / PPE GF10	PPE / PPE GF10	PPE / PPE GF10
Mounting	Profile rail 35 mm	Profile rail 35 mm	Profile rail 35 mm	Profile rail 35 mm
<b>Mechanical data</b>				
Dimensions (WxHxD)	48.5 mm x 109 mm x 76.5 mm	48.5 mm x 109 mm x 76.5 mm	48.5 mm x 109 mm x 76.5 mm	48.5 mm x 109 mm x 76.5 mm
Weight	155 g	155 g	155 g	155 g
<b>Environmental conditions</b>				
Operating temperature	0 °C to 60 °C	0 °C to 60 °C	0 °C to 60 °C	0 °C to 60 °C
Storage temperature	-25 °C to 70 °C	-25 °C to 70 °C	-25 °C to 70 °C	-25 °C to 70 °C
<b>Certifications</b>				
UL508 certification	yes	yes	yes	yes

# Connections, Interfaces

Interface modules | Fieldbus slave modules without I/Os

053-1CA00  
053-1DN00  
053-1DP00  
053-1EC00

053-1MT00  
053-1PN00

## 053-1CA00

**CAN**

- ① n.c.
- ② CAN low
- ③ CAN Ground
- ④ n.c.
- ⑤ n.c.
- ⑥ CAN high
- ⑦ n.c.
- ⑧ n.c.

## 053-1DN00

**DeviceNet**

- ① V-
- ② CL
- ③ DR
- ④ CH
- ⑤ V+
- ⑥ GND/opt.
- ⑦ CAN low
- ⑧ Drain/Shield
- ⑨ CAN high
- ⑩ DC 24 V/opt.

## 053-1DP00

**DP slave**

- ① shield
- ② n.c.
- ③ RoD/TxD-P (line B)
- ④ RTS
- ⑤ MSV
- ⑥ P5V
- ⑦ RoD/TxD-N (line A)
- ⑧ n.c.

## 053-1EC00

**2x RJ45 EtherCAT**

- ① Transmit +
- ② Transmit -
- ③ Receive +
- ④ -
- ⑤ -
- ⑥ Receive -
- ⑦ -
- ⑧ -

# Fieldbus slave modules without I/Os

Interface modules   Fieldbus slave modules without I/Os					
053-1CA00	053-1MT00				
053-1DN00	053-1PN00				
053-1DP00					
053-1EC00					

Order number	053-1MT00	053-1PN00		
Figure				
Type	IM 053MT	IM 053PN		
Module ID	-	-		
<b>General information</b>				
Note	-	-		
Features	<ul style="list-style-type: none"> <li>▸ Modbus/TCP slave</li> <li>▸ I/O configuration via fieldbus</li> <li>▸ Adjustable I/O cycle (0.5...4 ms)</li> <li>▸ max. 64 peripheral modules</li> </ul>	<ul style="list-style-type: none"> <li>▸ PROFINET-IO slave</li> <li>▸ Transfer rate 100Mbit/s</li> <li>▸ max. 64 peripheral modules</li> </ul>		
<b>Technical data power supply</b>				
Power supply (rated value)	DC 24 V	DC 24 V		
Power supply (permitted range)	DC 20.4...28.8 V	DC 20.4...28.8 V		
Reverse polarity protection	✓	✓		
Current consumption (no-load operation)	95 mA	95 mA		
Current consumption (rated value)	0.95 A	0.95 A		
Inrush current	3.9 A	3.9 A		
I <sup>2</sup> t	0.14 A <sup>2</sup> s	0.14 A <sup>2</sup> s		
Max. current drain at backplane bus	3 A	3 A		
Max. current drain load supply	10 A	10 A		
Power loss	3 W	3 W		
<b>Status information, alarms, diagnostics</b>				
Status display	yes	yes		
Interrupts	yes, parameterizable	yes, parameterizable		
Process alarm	yes, parameterizable	yes, parameterizable		
Diagnostic interrupt	yes, parameterizable	yes, parameterizable		
Diagnostic functions	yes, parameterizable	yes, parameterizable		
Diagnostics information read-out	possible	possible		
Supply voltage display	green LED	green LED		
Service Indicator	yellow LED	yellow LED		
Group error display	red SF LED	red SF LED		
Channel error display	none	none		
<b>Hardware configuration</b>				
Racks, max.	1	1		
Modules per rack, max.	64	64		
Number of digital modules, max.	64	64		
Number of analog modules, max.	64	64		
<b>Communication</b>				
Fieldbus	Modbus / TCP/IP	PROFINET-IO		
Type of interface	Ethernet 10/100 MBit	Ethernet 100 MBit		
Connector	RJ45	2 x RJ45		

Interface modules   Fieldbus slave modules without I/Os						
053-1CA00	053-1MT00					
053-1DN00	053-1PN00					
053-1DP00						
053-1EC00						

Order number	053-1MT00	053-1PN00		
Topology	-	-		
Electrically isolated	✓	✓		
Number of participants, max.	-	-		
Node addresses	-	-		
Transmission speed, min.	10 Mbit/s	100 Mbit/s		
Transmission speed, max.	100 Mbit/s	100 Mbit/s		
Address range inputs, max.	1 KB	512 Byte		
Address range outputs, max.	1 KB	512 Byte		
Number of TxPDOs, max.	-	-		
Number of RxPDOs, max.	-	-		
<b>Housing</b>				
Material	PPE / PPE GF10	PPE / PPE GF10		
Mounting	Profile rail 35 mm	Profile rail 35 mm		
<b>Mechanical data</b>				
Dimensions (WxHxD)	48.5 mm x 109 mm x 76.5 mm	48.5 mm x 109 mm x 76.5 mm		
Weight	155 g	155 g		
<b>Environmental conditions</b>				
Operating temperature	0 °C to 60 °C	0 °C to 60 °C		
Storage temperature	-25 °C to 70 °C	-25 °C to 70 °C		
<b>Certifications</b>				
UL508 certification	yes	yes		

# Connections, Interfaces

Interface modules | Fieldbus slave modules without I/Os

053-1CA00 053-1DN00 053-1DP00 053-1EC00	053-1MT00 053-1PN00				
--	------------------------	--	--	--	--

## 053-1MT00

**PM**

1 0.5  
2 0.6  
3 0.7  
4 0.8  
0 V

DC 24 V  
0 V

Sys DC 24 V

**NET**

- ① Transmit +
- ② Transmit -
- ③ Receive +
- ④ -
- ⑤ -
- ⑥ Receive -
- ⑦ -
- ⑧ -

## 053-1PN00

**PM**

1 0.5  
2 0.6  
3 0.7  
4 0.8  
0 V

DC 24 V  
0 V

Sys DC 24 V

**2x RJ45 PROFINET**

- ① Transmit +
- ② Transmit -
- ③ Receive +
- ④ -
- ⑤ -
- ⑥ Receive -
- ⑦ -
- ⑧ -

# SLIO accessories



## Structure and Function

System accessories expand the use of the system and facilitate starting.

### 35 mm profile rail

Using 35 mm profile rails the respective modules can be mounted directly on the mounting surface. The profile rail is available in various lengths.

### Manuals

The technical documentation of the respective modules includes various manuals with the necessary hardware and programming information, detailed descriptions of each module, and instructions for structure and assembly.

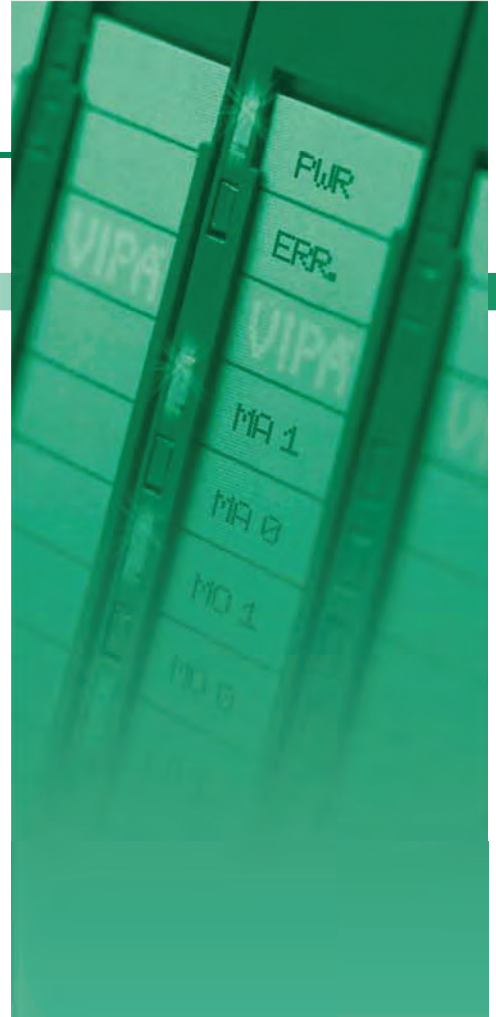

## SLIO starterKIT



Order number	Type	Description	Note
800-1DK10	SLIO_Starter-Kit 1- IM053DP	consisting of: 1 x IM 053DP - PROFIBUS-DP slave, 1x CM 001 Clamps module (4xDC 24V, 4xDC 0V Clamps), 1 x SM 021 Digital Input (DI 8xDC 24V), 1 x SM 021 Digital Input (DI 4xDC 24V), 1x SM 022 Digital Output (DO 4xDC 24V, 0,5A), 1x SM 031 Analog Input (AI 2x12Bit, U), 1x SM 032 Analog Output (AO 2x12Bit, U), 1x PROFIBUS cable ready for connecting including 2x PB connector (972-0DP01 + 972-0DP10), 1x profil rail, 1x SLIO USB stick (with GSD files, Manual, Catalog (german/english), example programs), 1x transport case	

## 35 mm profile rail



Order number	Type	Description	Note
290-1AF00	35 mm profile rail	length 2000 mm	
290-1AF30	35 mm profile rail	length 530 mm	

## Miscellaneous



Order number	Type	Description	Note
000-0AA00	SLIO bus cover		
000-0AB00	SLIO shield bus carrier	10 pieces	

## Manuals and operating instructions



Order number	Title	Contents	Language
HB300D	Manual system SLIO, German	Manual System SLIO - Compendium, German HB300D_CP, HB300D_SM-DIO, HB300D_SM-AIO, HB300D_IM, HB300D_FM, HB300D_PS-CM	DE
HB300E	Manual system SLIO, English	Manual System SLIO - Compendium, English HB300E_CP, HB300E_SM-DIO, HB300E_SM-AIO, HB300E_IM, HB300E_FM, HB300E_PS-CM	EN
HB300D_CP	Manual system SLIO - CP	CP - Communication processor	DE
HB300E_CP	Manual system SLIO - CP	CP - Communication processor	EN
HB300D_FM	Manual system SLIO - FM	FM - Function modules	DE
HB300E_FM	Manual system SLIO - FM	FM - Function modules	EN
HB300D_IM	Manual system SLIO - IM	IM - Interface modules	DE
HB300E_IM	Manual system SLIO - IM	IM - Interface modules	EN
HB300D_PS-CM	Manual system SLIO - PS-CM	PS-CM - Power modules / Clamp modules	DE
HB300E_PS-CM	Manual system SLIO - PS-CM	PS-CM - Power modules / Clamps modules	EN
HB300D_SM-AIO	Manual system SLIO - SM-AIO	SM-AIO - Analog Signal modules	DE
HB300E_SM-AIO	Manual system SLIO - SM-AIO	SM-AIO - Analog Signal modules	EN
HB300D_SM-DIO	Manual system SLIO - SM-DIO	SM-DIO - Digital Signal modules	DE
HB300E_SM-DIO	Manual system SLIO - SM-DIO	SM-DIO - Digital Signal modules	EN
HB300D_SM-S	Manual system SLIO - SM-S	SM-DIO - Safety Digital Signal modules	DE
HB300E_SM-S	Manual system SLIO - SM-S	SM-DIO - Safety Digital Signal modules	EN

